

PROGRAMMABLE DISPLAY

WHA1 Series

# User's Manual

---

Hardware

---

## Safety Precautions

---

Observe the following notices to ensure personal safety or to prevent accidents.  
To ensure that you use this product correctly, read this User's Manual thoroughly before use.  
Make sure that you fully understand the product and information on safety.  
This manual uses two safety flags to indicate different levels of danger.

---

### WARNING

---

**If critical situations that could lead to user's death or serious injury is assumed by mishandling of the product:**

- Always take precautions to ensure the overall safety of your system, so that the whole system remains safe in the event of failure of this product or other external factor.
- DO NOT USE THE PROGRAMMABLE DISPLAY TO CONTROL SAFETY FEATURES OR OTHER CRITICAL OPERATIONS OF EQUIPMENT OR SYSTEMS. A COMMUNICATION ERROR (FOR ANY REASON) MIGHT PREVENT SUCH SAFETY FEATURES OR CRITICAL OPERATIONS FROM FUNCTIONING PROPERLY.
- Do not use this product in areas with inflammable gas. It could lead to an explosion.
- Exposing this product to excessive heat or open flames could cause damage to the electronic parts.

---

### CAUTION

---

**If critical situations that could lead to user's injury or only property damage is assumed by mishandling of the product.**

- To prevent excessive exothermic heat or smoke generation, use this product at the values less than the maximum of the characteristics and performance that are assured in these specifications.
- Do not dismantle or remodel the product. It could cause excessive exothermic heat or smoke generation.
- Do not touch the terminal while turning on electricity. It could lead to an electric shock.
- Use the external devices to function the emergency stop and interlock circuit.
- Connect the wires or connectors securely.
- The loose connection could cause excessive exothermic heat or smoke generation.
- Do not allow foreign matters such as liquid, flammable materials, metals to go into the inside of the product. It could cause excessive exothermic heat or smoke generation.
- Do not undertake construction (such as connection and disconnection) while the power supply is on. It could lead to an electric shock.
- The product is a programmable display unit designed to be connected to an industrial control device such as a PLC (Programmable Logic Controller).

---

### Copyright / Trademarks

---

- This manual and its contents are copyrighted.
- You may not copy this manual in whole or part, without written consent of Panasonic Industry Co., Ltd.
- Windows is a registered trademark of Microsoft Corporation in the United States and other countries.
- Ethernet is a registered trademark of FUJIFILM Business Innovation Corp and Xerox Corporation in the United States.
- SDHC and SD logos are trademarks of SD-3C, LLC.
- All other company names and product names are trademarks or registered trademarks of their respective owners.

## Information Security Precautions

When use this product you might receive damage as listed below.

- (1) Information leakage or outflow through this product
- (2) Fraudulent operation of this product by a malicious third party
- (3) Obstructing or stopping this product by a malicious third party

Sufficient measures, including the following measures, should be taken at your own risk to prevent such damages.

### ■ Data storage

- Do not storage of personal information on this product.

### ■ Password

- Please be sure to change the password since it is set to the default value at the time of purchase.
- Do not use the default password.
- Manage your password responsibly and do not forget it. If you forget the internal password, reset the unit to factory defaults.
- Do not tell your password to others or write down your password since security risk can occur if the password becomes known to a third party.
- Please make sure that your password is at least 8 characters long and contains a combination of upper and lower case letters, numbers and symbols so that a third party cannot guess your password.
- Do not use the same password as your user name. Do not use the same password as the one you are using elsewhere.
- Please change your password on a regular basis.

### ■ Networks

- Use this product on a network where safety is secured by using a firewall.
- When using this product on a system where a PC is connected, make sure that checking and cleaning of infection by computer virus or malicious program is performed periodically.
- It has the ability to use unencrypted communications. (FTP, HTTP, SMTP, PLC communications, etc.).
- Please make sure that a third party cannot easily connect to the network used by this product.
- Use HTTPS when accessing this product through a web browser.
- Also, be sure to close all browsers after accessing it.
- Do disable the functions of the services you don't use. (SNMP, NTP, VNC, DHCP, Corvina Cloud, etc.)
- Be sure to log out when you have completed the necessary setup operations.
- Do not install this product or cables in a place where they can be easily destroyed or altered.
- SNMP is assumed to be used for testing purposes. It should be disabled during operation.
- Furthermore, it is recommended that the product be used in an environment that has VPN (Virtual Private Network) or leased line network.

### ■ Transfer/ Disposal/ Repair

- If the product is to be disposed of, transferred, repaired, or otherwise transferred to a third party, important information may also be recorded on the product and on the external recording media used. At customer's risk, please handle it with care, such as erasing it.

### ■ Installation

- On the back of the unit, there are interfaces that affect its operation, such as power supply, external storage media, and communication connectors. Please make sure to install the unit in a manner that does not allow unauthorized parties to touch it.

### ■ Exemption

The Company shall not be responsible for any information security problems or damages that may occur to you in the event that you fail to comply with the above precautions in using this product.

## Safety Guide

The manual contains safety standards that must be respected for the personal safety and to avoid damage.

Indications of attention are divided into three levels of severity:

**CAUTION:** indicates a failure to observe safety rules and that deficiency may cause damage.



**CAUTION**

**Note:** indicates a failure to observe safety rules and that deficiency may cause defects to the equipment or inconsistencies.



**Note**

## Introduction

Thank you for buying a Panasonic product. Before you use the product, please carefully read the installation instructions and the user's manual, and understand their contents in detail to use the product properly.

## Types of Manual

- There are different types of user's manual for the WHA1 series, as listed below. Please refer to a relevant manual for the unit and purpose of your use.
- The manuals can be downloaded on our download center:  
<https://industry.panasonic.com/global/en/downloads/?tab=manual>

Unit name or purpose of use	Manual name	Manual code
Programmable Display WHA1 series	WHA1 series User's Manual (Hardware)	WUME-WHA1
Tool Software xAscender Studio	xAscender Studio User's Manual (Basic)	WUME-XASCEN-BAS
	xAscender Studio User's Manual (Communication)	WUME-XASCEN-COM

(Note 1) The screen creation software: "Terminal GTWIN" and IP address Search Tool: "Configurator WD" are not supported.

---

**Table of Contents**

---

<b>1 System Configuration</b>	<b>1</b>
1.1 WH series Advanced Model Main Unit	1
1.2 Screen Creating Tool	1
1.3 Remote monitoring Tool	1
<b>2 Names and Functions of Parts</b>	<b>2</b>
2.1.1 AWAHA1C105	2
2.1.2 AWAHA1C070, AWAHA1C101, AWAHA1C156, AWAHA1C215	2
2.2 Wiring the Power Supply	3
2.3 Grounding	4
2.4 Serial Port	4
2.4.1 Wiring Example of Serial Port	5
2.5 Ethernet Port	6
2.6 DISPOSE OF BATTERIES	6
2.6.1 Detaching method of batteries	6
<b>3 Installation</b>	<b>8</b>
3.1 Installation Environment	8
3.2 Installation Method	8
<b>4 Specifications</b>	<b>9</b>
4.1.1 General Specifications	9
4.1.2 Performance Specifications	10
4.1.3 Function Specifications	11
4.1.4 Interface	12
4.2 Dimensions	15
4.2.1 AWAHA1C050	15
4.2.1 AWAHA1C070, AWAHA1C101, AWAHA1C156, AWAHA1C215	16
4.3 Installation Dimensions Drawing	17
4.3.1 AWAHA1C050	17
4.3.2 AWAHA1C070	18
4.3.3 AWAHA1C101	19
4.3.4 AWAHA1C156	20
4.3.5 AWAHA1C215	21
<b>5 System Settings</b>	<b>22</b>
<b>Revision History</b>	<b>26</b>

## Before You Start

---

### ■ Usage conditions

- Ambient temperatures: -20 to 50 °C
- Ambient humidity should be 5 to 85% RH (at +25 °C and non-condensing.)
- Usable altitude: 2000 m above sea level or lower
- For use in pollution degree 2 environment
- Do not use it in the following environments.
  - Direct sunlight, wind and rain. (This product is not designed for outdoor use.)
  - Inflammable or corrosive gas.
  - Excessive airborne dust, metal particles or saline matter.
  - Benzine, paint thinner, alcohol or other organic solvents or strong alkaline solutions such as ammonia or caustic soda.
  - Direct vibration, shock or places always exposed to drop of water.
  - This unit is warranted by IP66, IP20 for panel mounting, however, this applies to initial values and evaluated by us.
  - Influence from power transmission lines, high voltage equipment, power cables, power equipment, radio transmitters, or any other equipment that would generate high switching surges. (100 mm or more)
- The vents in the panel casing must not be obstructed.

### ■ Static electricity

- Do not touch connector pins directly to prevent static electricity from causing damage.
- Always rid yourself of any static electricity before handling this product.
- If excessive static electricity is applied to the panel surface, the LCD panel may be damaged.

### ■ Power Supply

- Twist the wires of the power supply.
- The unit has sufficient noise immunity against the noise generated on the power line.
- However, it is recommended to take measures for reducing noise such as using an isolating transformer before supplying the power. And it is recommended to take measures such as installing a ferrite core.
- Allocate an independent wiring for each power supplying line, PLC etc. and operating device.
- If using a power supply without a protective circuit, power should be supplied through a protective element such as fuse. Directly applying an abnormal voltage to the unit may cause the damage to the internal circuit.
- Transient protection shall be provided that is set at a level not exceeding 140 % of the peak rated voltage value at the supply terminals to the equipment.
- DO NOT DISCONNECT WHILE CIRCUIT IS LIVE

### ■ Selection of wires

- Use a wire of which temperature rating is 105 °C or more.

### ■ Touch switches

This product uses the capacitive type.

- Be sure to use your fingers to operate the touch switch. Do not use your claw to operate the touch switch.
- Do not press or scratch the surface of the touchscreen with a hard object.
- If a large amount of water droplets are attached to the touchscreen, it will be falsely detected or misrecognized. Wipe off the water droplets with a thick, dry cloth.
- Gloves may cause the touch switch not to respond. Please take off the gloves.

■ LCD panel

- Do not drop or have a strong impact on the programmable display unit as glass is used for the LCD panel.
- The liquid in the LCD panel is a hazardous substance. If the LCD panel is broken, do not put the leaked crystalline liquid into your mouth. Should it get into your mouth, immediately gargle, and consult a doctor. If it adheres to your skin or clothes, wash it away with soap.
- On the LCD panel, bright spots ( points always lit) or black spots (points always unlit) may appear, or the uneven brightness, flickers or crosstalk (appearance of unintended shades in the area no graphic or part is arranged) may occur depending on the operating conditions.
- Note that these phenomena are resulted from the basic characteristics of LCD panel not defects or failures of the product.
- The equipment must be cleaned only with a soft cloth. Do not use solvents.

■ Scratch protection sheet

- A sheet is affixed to the touch panel to protect it from scratches when shipping. Please remove it before using the HMI.

■ Cautions on handling a USB memory

- Do not remove the USB memory while the power is on.\*  
\*Communication may be stopped. It is necessary to restart the power supply to recover.
- The data saved in the USB memory may be lost in the following cases. We assume no responsibility whatsoever for the lost of saved data.
  - (1) When a user or third party used the USB memory incorrectly.
  - (2) When the USB memory was affected by any static electricity or electrical noise.
  - (3) When the USB memory was removed or the power supply of the HMI unit was turned off while data was being read, written or deleted to/from the USB memory.
- It is recommended to save important data in another media for backup.

■ Cautions on handling a SD memory card

- Do not remove the SD memory card while the power is on.\*  
\*Communication may be stopped. It is necessary to restart the power supply to recover.
- The data saved in the SD memory card may be lost in the following cases. We assume no responsibility whatsoever for the lost of saved data.
  - (1) When a user or third party used the SD memory card incorrectly.
  - (2) When the SD memory card was affected by any static electricity or electrical noise.
  - (3) When the SD memory card was removed or the power supply of the HMI unit was turned off while data was being read, written or deleted to/from the SD memory card.
- It is recommended to save important data in another media for backup.

# 1 System Configuration

## 1.1 WH series Advanced Model Main Unit

Model No.	Display	Touch switch	Front cover	Power Supply	communication		USB	SD
					Ethernet	Serial		
AWHA1C050	5.0 inch wide TFT	Capacitive type	—	24V DC	2ch	1ch	1ch	1Slot
AWHA1C070	7.0 inch wide TFT				3ch	RS-232C/ RS-422/RS-485 ※software configurable	2ch	
AWHA1C101	10.1 inch wide TFT							
AWHA1C156	15.6 inch wide TFT							
AWHA1C215	21.5 inch wide TFT							

## 1.2 Screen Creating Tool

This software is used for creating screens and making various settings.

Item name	Required OS	Hard disk capacity	Remarks
Tool Software xAscender Studio	Windows 10 Windows 11	1GB or more	It is installed at the same time you install xAscender Suite.

You can download from our website.

(<https://industry.panasonic.com/global/en/downloads/?tab=software>) (Member registration is necessary, free of charge.)

### (Notes)



xAscender cannot start normally due to the computer management software used as a security measure. In that case, try starting xAscender with administrator privileges. In addition, exclude from the monitoring target by setting the whitelist etc. in the management software.

## 1.3 Remote monitoring Tool

This software is used for remote monitoring tool.

Item name	Required OS	Hard disk capacity	Remarks
Tool Software xAscender Client	Windows 10 Windows 11	—	It is installed at the same time you install xAscender Suite.

### (Notes)



xAscender cannot start normally due to the computer management software used as a security measure. In that case, try starting xAscender with administrator privileges. In addition, exclude from the monitoring target by setting the whitelist etc. in the management software.



## 2 Names and Functions of Parts

### 2.1.1 AWAH1C105

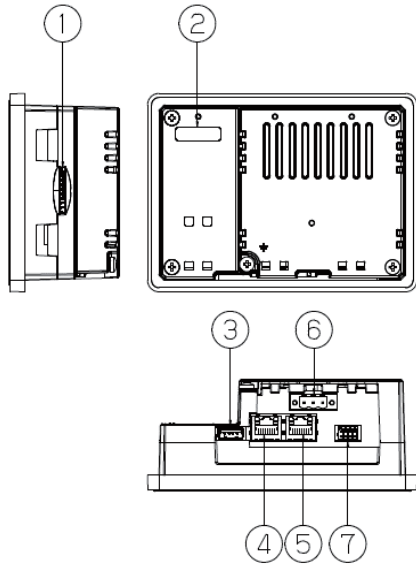

No.	Description
1	SD Card Slot
2	Do not use *Do not remove the protection seal on the rear.
3	USB Port (1 Port)
4	Ethernet Port 0 (WAN)
5	Ethernet Port 1 (LAN)
6	Power
7	Serial Port

### 2.1.2 AWAH1C070, AWAH1C101, AWAH1C156, AWAH1C215

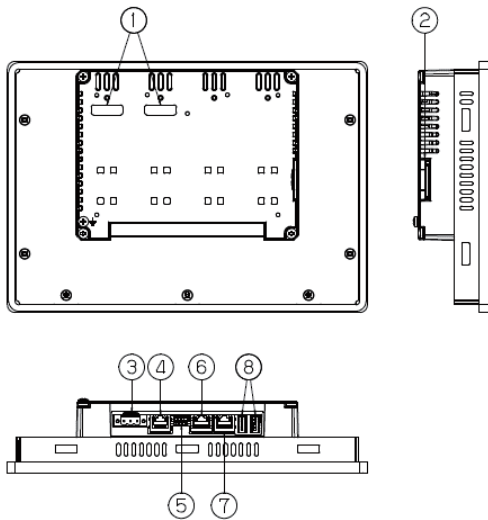

No.	Description
1	Do not use *Do not remove the protection seal on the rear.
2	SD Card Slot
3	Power Supply
4	Ethernet Port 0 (WAN)
5	Serial Port
6	Ethernet Port 1 (LAN)
7	Ethernet Port 2 (LAN)
8	USB Port (2 Ports)

## 2.2 Wiring the Power Supply

Use an external 24 V DC power supply.

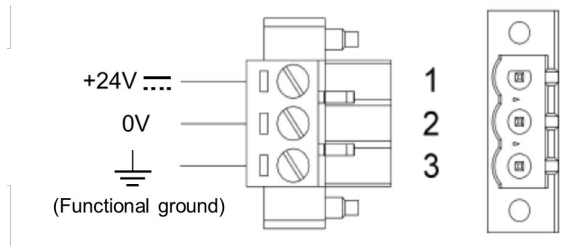

■ Suitable wires

Size	Nominal cross sectional area	Rated temperature	Tightening torque
AWG 24 to 14	0.2 to 2mm <sup>2</sup>	105°C or more	0.4 to 0.5 N·m



**(Note 1)** If the power supply is incorrect, the internal electronic components may be damaged.

**(Note 2)** Ensure that the power supply has enough power capacity for the operation of the equipment.

**(Note 3)** Please use the SELV (Safety Extra-Low Voltage) and LIM (Limited Energy Circuit) power supply.

**(Note 4)** Since this product is a capacitive type, the touch switch may be unable to respond if it is not grounded.

**(Note 5)** Precautions concerning wiring

- When removing the wire's insulation, be careful not to scratch the core wire.
- Do not twist the wires to connect them.
- Do not solder the wires to connect them. The solder may break due to vibration.
- After wiring, make sure stress is not applied to the wire.
- In the terminal block socket construction, if the wire is fastened upon counter-clockwise rotation of the screw, the connection is faulty. Disconnect the wire, check the terminal hole, and then re-connect the wire.

The unit must always be grounded to earth with 1.5mmsq wire size minimum.

Earth connection will have to be done using either the screw (M4) located near the power supply terminal block. Also connect to ground the terminal 3 on the power supply terminal block.

The power supply circuit may be floating or grounded. In the latter case, connect to ground the power source common as shown in figure (see below) with a dashed line.

When using the floating power scheme, note that the HMI devices internally connects the power common to ground with a 1MΩ resistor in parallel with a 4,7nF capacitor.

The power supply must have double or reinforced insulation.

The suggested wiring for the power supply is shown in figure.

All the electronic devices in the control system must be properly grounded.

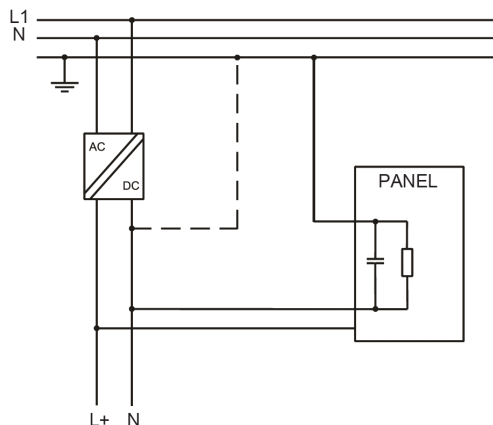

## 2.3 Grounding

### Use dedicated grounding:

- make the grounding point as close as possible to the GT and keep the distance of the grounding wire short.
- sharing the ground with another device may have an adverse effect. Therefore, be sure that grounding is dedicated.

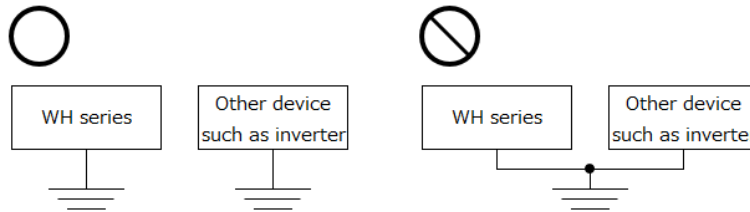

### (Notes)



- Conversely, depending on your environment, grounding may cause a problem.
- Since the power line of the HMI unit is connected to a functional earth via electronic parts, the electronic parts may become damaged if there is an abnormal potential between the power line and the physical ground.

## 2.4 Serial Port

The serial port is used to communicate with the PLC or with another type of controller.

Standards available for the signals in the PLC port connector are: RS-232, RS-422 and RS-485.

The serial port is software programmable.

Make sure you select the appropriate interface in the programming software.

To operate in RS485 pins 1-2 and 3-4 must be connected externally.

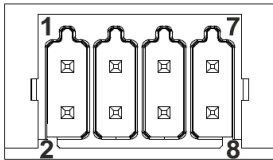

Pin No.	Pin name	Serial		
		RS-232C	RS-422	RS-485
1	RX/RXD-	RxD	RXD-	RXD-
2	TX/TXD-	TxD	TXD-	TXD-
3	CTS/RXD+	CTS	RXD+	RXD+
4	RTS/TXD+	RTS	TXD+	TXD+
5	+5V output	-	-	-
6	GND	-	-	-
7	-	-	-	-
8	SHIELD	SHIELD	SHIELD	SHIELD

To connect to the serial port, use a connector provided with the unit.

### ■ Suitable wires

Size	Nominal cross sectional area	Rated temperature
AWG24 to 20	0.2 to 0.5mm <sup>2</sup>	105°C or more

## 2.4.1 Wiring Example of Serial Port

Use a loose wire for the connection on the PLC side.

It can be used in combination with our PLC equipped with an adaptive interface.

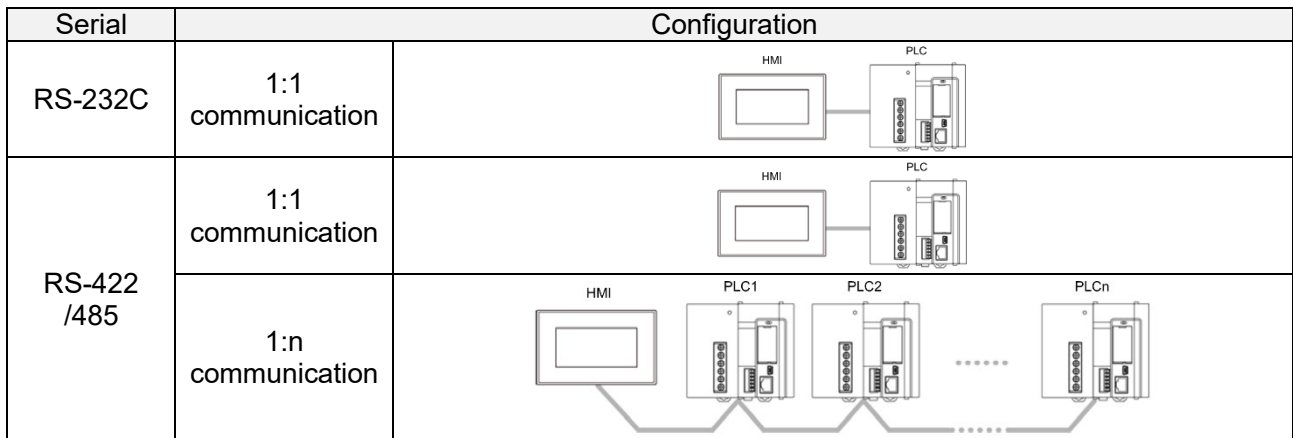

### ■ RS-232C Communication

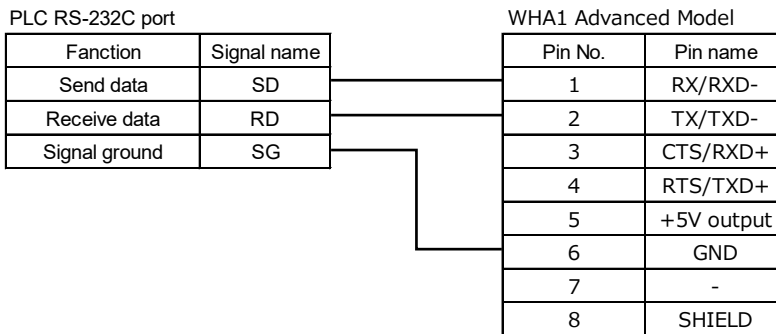

### ■ RS-422 Communication

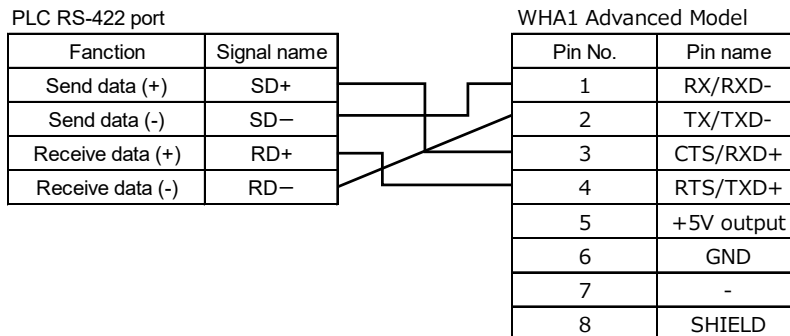

### ■ RS-485 Communication

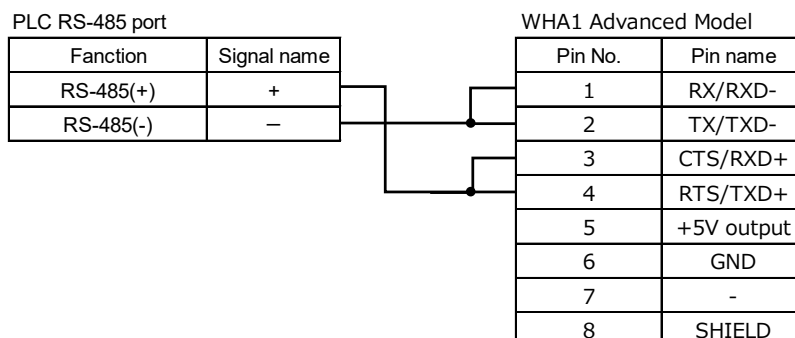

## 2.5 Ethernet Port

The Ethernet port have two LED indicators for status. Please see description below.

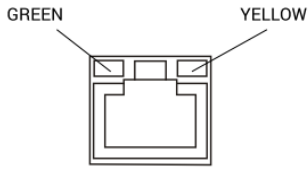

■AWHA1C050

Green	Yellow	Remarks
ON	OFF	No LAN cable connected
BLINK	ON	LINK at 100 Mbps
BLINK	OFF	LINK at 10 Mbps

■AWHA1C070, AWAHA1C101, AWAHA1C156, AWAHA1C215

Ethernet port 0		
Green LED	Yellow LED	Description
ON	OFF	No LAN cable connected
BLINK	OFF	LINK at 10/100 Mbps
Ethernet port 1 and Ethernet port 2		
Green LED	Yellow LED	Description
ON	OFF	No LAN cable connected
BLINK	ON	LINK at 100 Mbps
BLINK	OFF	LINK at 10 Mbps

## 2.6 DISPOSE OF BATTERIES

These devices are equipped with rechargeable Lithium battery, not user-replaceable.

When disposing of this product, remove and dispose of the batteries according to the following procedures.



**(Note 1)** Dispose of batteries according to local regulations.

**(Note 2)** When detaching the battery, be sure to disconnect the power cable so that power can not be supplied to the device. There is a risk of electrical shock.

### 2.6.1 Detaching method of batteries

■AWHA1C050

1. Remove the main unit case mounting screws and remove the case.
2. Disconnect the cable connected to the board from the connector. Alternatively, use a nipper to cut the cable.
3. The battery is located on the back of the board as shown in the illustration, using the nipper remove the battery from the board

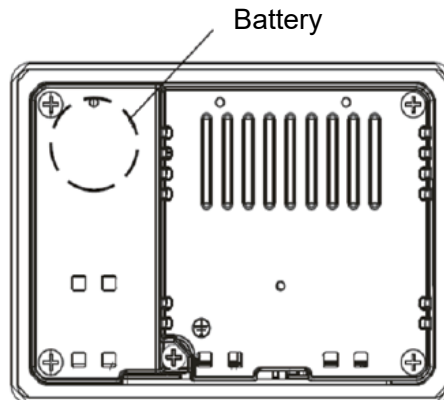

■ **AWHA1C070, AWAH1C101, AWAH1C156, AWAH1C215**

1. Remove the main unit case mounting screws and remove the case.
2. The battery is located on the back of the board as shown in the illustration, using the nipper

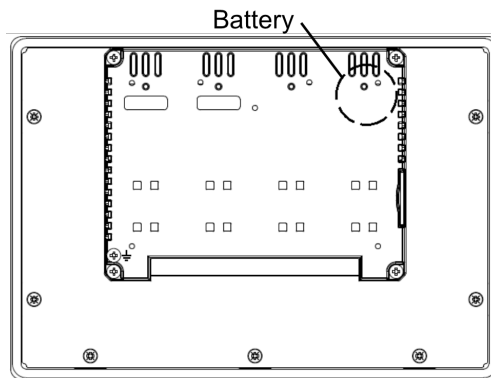

## 3 Installation

### 3.1 Installation Environment

In order to meet the front panel protection classifications, proper installation procedure must be followed:

- the borders of the cutout must be flat
- screw up each fixing screw until the plastic bezel corner get in contact with the panel.
- the cutout for the panel must be of the dimensions indicated in this manual.

The IP66 is guaranteed only if:

- max deviation from the plane surface to the cut-out:  $\leq 0.5$  mm
- thickness of the case where is mounted the equipment: from 1.5 mm to 6 mm
- max surface roughness where the gasket is applied:  $\leq 120$   $\mu$ m

A: WHA1 Advanced Model  
B: Installation cut-out

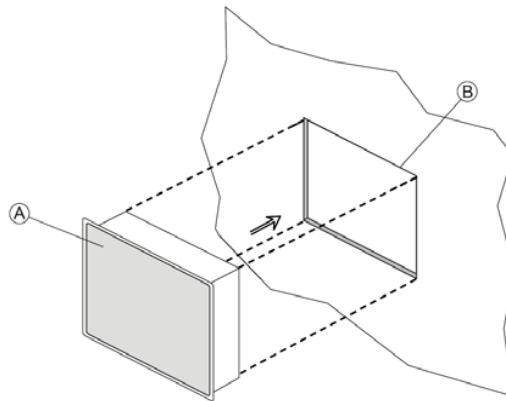

(Note 1) The equipment is not intended for continuous exposure to direct sunlight.

(Note 2) The equipment is not intended for installation in contact with corrosive chemical compounds.

(Note 3) Do not use tools of any kind (screwdrivers, etc.) to operate the touch screen of the panel.

(Note 4) The vents in the panel casing must not be obstructed.

(Note 5) Chemical resistance of the panel front surface: The following chemicals show no visible changes after 24-hour exposure.

Hydrogen peroxide solution, betadine (povidone iodine solution 10%), cola, electrode gel/paste, hydrogen peroxide (3% solution), NaCl (0.9% solution), coffee, dextrose (5% glucose solution), hydrogen chloride (0.5% solution, pH = 1), isopropyl alcohol, sodium hypochlorite, ethyl alcohol (70% to 90%), quaternary ammonium compound

### 3.2 Installation Method

Place the fixing brackets contained in the fixing kit.

Tightening torque: 1.3N·m or screw each fixing screw until the bezel corner gets in contact with the panel.

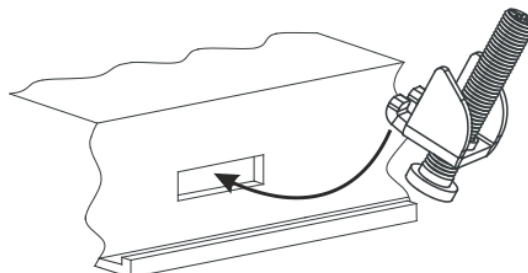

## 4 Specifications

### 4.1.1 General Specifications

Item	Specifications				
	AWhA1C050	AWhA1C070	AWhA1C101	AWhA1C156	AWhA1C215
Rated Voltage	24V DC				
Operating voltage range	10 to 32V DC (Note 1)				
Current rating (at 24VDC)	0.6A or less	0.7A or less	1A or less	1.2A or less	1.7A or less
Ambient temperature	-20 to +50°C *In vertical installation conditions				
Ambient humidity	5 to 85% RH (at +25°C, non-condensing)				
Storage temperature	-20 to +70°C				
Storage humidity	5 to 85%RH (at +25°C, non-condensing)				
Vibration resistance	5 to 9 Hz, 3.5-mm single amplitude 9 to 150 Hz, Acceleration 9.8m/s <sup>2</sup> (1 G)				
Shock resistance	±490m/s <sup>2</sup> (50 G), 11 ms, 3 times in the X, Y, Z directions				
Protective construction (Note 2)	Front panel: IP66(Initial value, evaluated by us) Rear: IP20				
Pollution degree environment	2				
Weight	Approx.1kg	Approx.1.3kg	Approx.2.5kg	Approx.4.1kg	Approx.6.1kg



**(Note 1)** The voltage tolerance range for maintaining a 10ms voltage dips is limited to 20.4 to 32V DC. \* Does not include connection of external devices.

**(Note 2)** Refer to the 3. Installation.



## 4.1.2 Performance Specifications

Item		Specifications				
		AWHA1C050	AWHA1C070	AWHA1C101	AWHA1C156	AWHA1C215
Display (Note 1)	Display Unit	TFT color LCD 5.0 inch wide	TFT color LCD 7.0 inch wide	TFT color LCD 10.1 inch wide	TFT color LCD 15.6 inch wide	TFT color LCD 21.5 inch wide
	Resolution	800×480, WVGA	800×480, WVGA	1280×800, WXGA	1366×768, HD	1920×1080, Full HD
	Colors	65,536 colors	16,770,000 colors			
	Backlight	White LED				
	Backlight brightness	300cd/m <sup>2</sup> (typ.)	500cd/m <sup>2</sup> (typ.)	500cd/m <sup>2</sup> (typ.)	400cd/m <sup>2</sup> (typ.)	300cd/m <sup>2</sup> (typ.)
	Dimming	Yes Can be adjusted on the menu screen, xAscender Studio settings. (There are some minor variations in the backlight brightness.)				
	Backlight life time	40,000 hours or more (Note 2)				
Touch switch	Touch switch	Capacitive type				
Memory space	RAM	512MB	1GB		2GB	
	Memory	4GB	4GB		8GB	
	Project memory	240MB				
	User memory	512MB				
RTC / Backup	Accuracy RTC	±100ppm or less (at +25°C) (Note 3)				
	Function	Clock/Calendar				
	Period	Lithium batteries (secondary batteries) / 3 months (Requires 48 hours of power) (at +25°C) (Note 4)				
Other	Buzzer	Yes				



**(Note 1)** On the LCD panel, bright spots ( points always lit) or black spots (points always unlit) may appear, or the uneven brightness, flickers or crosstalk (appearance of unintended shades in the area no graphic or part is arranged) may occur depending on the operating conditions. Note that these phenomena are resulted from the basic characteristics of LCD panel not defects or failures of the product.

**(Note 2)** Time of continuous operation until the brightness of the backlight reaches 50% of the rated value when the surrounding air temperature is +25°C.

**(Note 3)** At +25°C: less than 260 seconds per month.

**(Note 4)** Must be charged for 48 hours. When the battery is fully charged, it ensures a period of 3 months of data backup.

### 4.1.3 Function Specifications

Item	Specifications
Displayable fonts	Fixed Font True Font Fonts installed in windows (Note 2)
Number of registerable screens (pages) (Note 1)	Max. 1000
Registerable screen number	Pages: 1000 Dialog: 50 Template: 50
Types of widget	Basic (text and numerical value) Button Meter Switch Light Media Icon Custom etc.
Main functions	Trends Reports Alarms Scheduler Database Data Transfers Recipe Keypads Web Server etc. * Refer to xAscender Studio User's Manual (Basic).
Through function	Communication between our PLC and a computer is available by connecting the computer to the Ethernet port and the PLC to the COM port.



**(Note 1)** Number of registerable screens (pages) varies depending on the registration contents.

**(Note 2)** A license (permission to use) is required to add the font.

## 4.1.4 Interface

### ■ Serial Port

Item		Specifications	
		RS-232C type	RS-422 / RS-485 type
Communication standard		Conforms to RS232C (Non insulation type)	Conforms to RS-422 / RS-485 (Non insulation type)
Port number		1CH *software configurable	
Conditions for communication with external devices	Baud rate (bits/s)	1200/2400/4800/9600/ 19200/38400/57600/115200 (Note 1)	1200/2400/4800/9600/ 19200/38400/57600/115200 (Note 1)
	Data bits (bits)	7/8	7/8
	Parity	none/even/odd	none/even/odd
	Stop bit (bit)	1/2	1/2
Transmission distance (Total length)		Max. 15m (Baud rate: 19,200 bps)	Max. 500m (Baud rate: 115,2 kbps)
Terminal resistance value		–	No Termination (Note 2)
Protocol		Refer to xAscender Studio User's Manual (Communication).	
Connector		Connector provided with the unit.	



**(Note 1)** Depend on PLC.

Please check with the actual devices when some commercial devices with RS485 interface are connected. The number of connected devices, transmission distance, and transmission speed may be different according to using transmission line.

**(Note 2)** When connected to the termination, it is recommended that a 120Ω, 1/2W or better termination resistor be connected between the communication lines.

## ■ Ethernet Port

Item	Specifications				
	AWHA1C050	AWHA1C070	AWHA1C101	AWHA1C156	AWHA1C215
Port number	2CH		3CH		
Connection method	Ethernet port 0: WAN Ethernet port 1: LAN		Ethernet port 0: WAN Ethernet port 1: LAN Ethernet port 2: LAN		
Interface	100BASE-TX / 10BASE-T				
Baud rate (Note 1)	100Mbps / 10Mbps				
Connector shape	RJ-45 (Note 2)				
Cable total length	100m (500m when using a repeater) (Note3)				
Communication cable	UTP cable (Category 5)				
Number of simultaneous connections	Max. 4				
communication method	Full-duplex/Half-duplex				
communication protocol	TCP/IP, UDP				
DNS	Name server support				
DHCP	Correspondence of automatic IP address acquisition				
FTP server / client	Server function: Transfer file Client function: Transfer data and file				
HTTP server / client	Server function: customer web Client function: Web browser				
SNTP	Correspondence of Time setting function				
Protocol	Refer to xAscender Studio User's Manual (Communication).				



**(Note 1)** Switching between different speeds is done automatically by auto negotiation function.

**(Note 2)** Be careful not to apply excessive static electricity to the metal parts of the connector.

**(Note 3)** The maximum length of the cable is 100m in accordance with the standards, but depending on the operating environment, a ferrite core may be installed to reduce noise. May be required. It is also recommended that the hub be installed near the control panel and that it be used at 10 meters or less.

## ■ USB Port

Item	Specifications				
	AWHA1C050	AWHA1C070	AWHA1C101	AWHA1C156	AWHA1C215
Port number	1CH		2CH		
Communication standard	High-Speed USB 2.0 (Host Controller)				
Connector shape	USB Type A				
Transmission speed	480Mbps (High Speed)				
Maximum current	Max. 500mA				



**(Note 1)** Take care of handling of the connector not to add an excessive static electricity on the metal part of the connector.

**(Note 2)** The format of the external memory should be in FAT32 or FAT.

The max number of files inside external memory depends on the type of formatting.

- FAT32 max 65535 files

- FAT max 512 files

**(Note 3)** Do not remove the USB memory while the power is on.\*

\*Communication may be stopped. It is necessary to restart the power supply to recover.

### ■ SD memory card

Item	Specifications
Support media	SD memory card, SDHC memory card (Note 1)
Supported format standard	Conforms to SD standard. (Note2) (Please format with a format software for SD memory cards.)



**(Note 1)** Industrial or business use SD memory cards (SLC type) are recommended.

**(Note 2)** Check the operating temperature range of the SD memory card before use.

**(Note 3)** The format of the external memory should be in FAT32 or FAT.

The max number of files inside external memory depends on the type of formatting.

- FAT32 max 65535 files

- FAT max 512 files

**(Note 4)** Do not remove the SD memory card while the power is on.\*

\*Communication may be stopped. It is necessary to restart the power supply to recover.

### ■ Cautions on handling a SD memory card

- The data saved in the SD memory card may be lost in the following cases. We assume no responsibility whatsoever for the lost of saved data.
  - (1) When a user or third party used the SD memory card incorrectly.
  - (2) When the SD memory card was affected by any static electricity or electrical noise.
  - (3) When the SD memory card was removed or the power supply of the HMI unit was turned off while data was being read, written or deleted to/from the SD memory card.
- It is recommended to save important data in another media for backup.

### ■ Formatting an SD memory card

Download formatting software for SD memory card on the following website.

#### ● Website

<https://industry.panasonic.com/global/en/products/fasys/information/sd-card/>

## 4.2 Dimensions

### 4.2.1 AWAH1C050

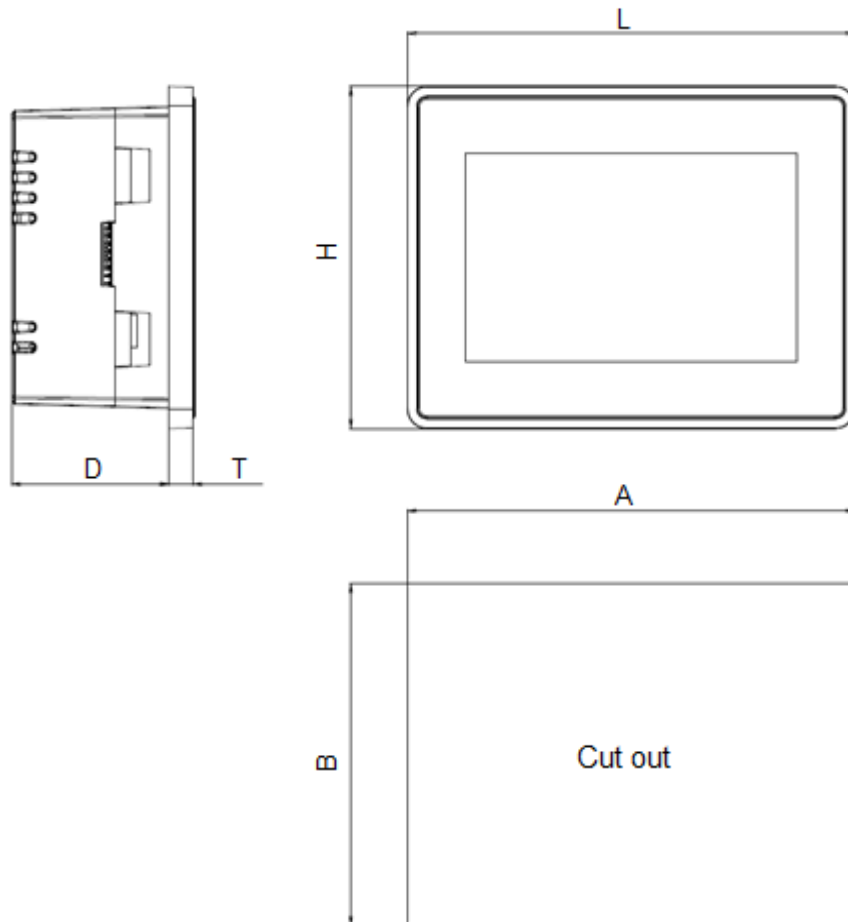

Model No.	A	B
AWHA1C050	136	96

Model No.	L	H	D	T
AWHA1C050	147	107	(52)	8.5

Unit: mm  
 Tolerance (except T):  $\pm 1$   
 T Tolerance:  $\pm 0.5$

4.2.1 AWAH1C070, AWAH1C101, AWAH1C156, AWAH1C215

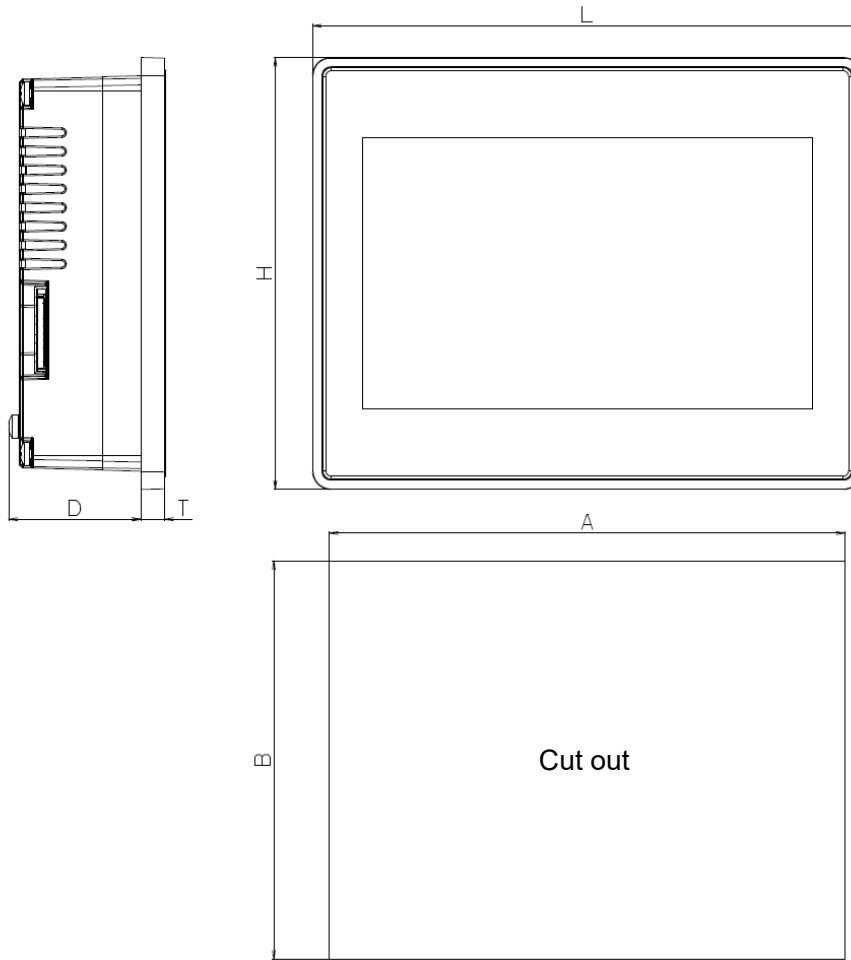

Model No.	A	B
AWHA1C070	176	136
AWHA1C101	271	186
AWHA1C156	411	256
AWHA1C215	541	336

Model No.	L	H	D	T
AWHA1C070	187	147	(45)	8.5
AWHA1C101	282	197	(52)	8.5
AWHA1C156	422	267	(56)	8.5
AWHA1C215	552	347	(56)	8.5

Unit: mm  
 Tolerance (except T): ±1  
 T Tolerance: ±0.5

### 4.3 Installation Dimensions Drawing

#### 4.3.1 AWAHA1C050

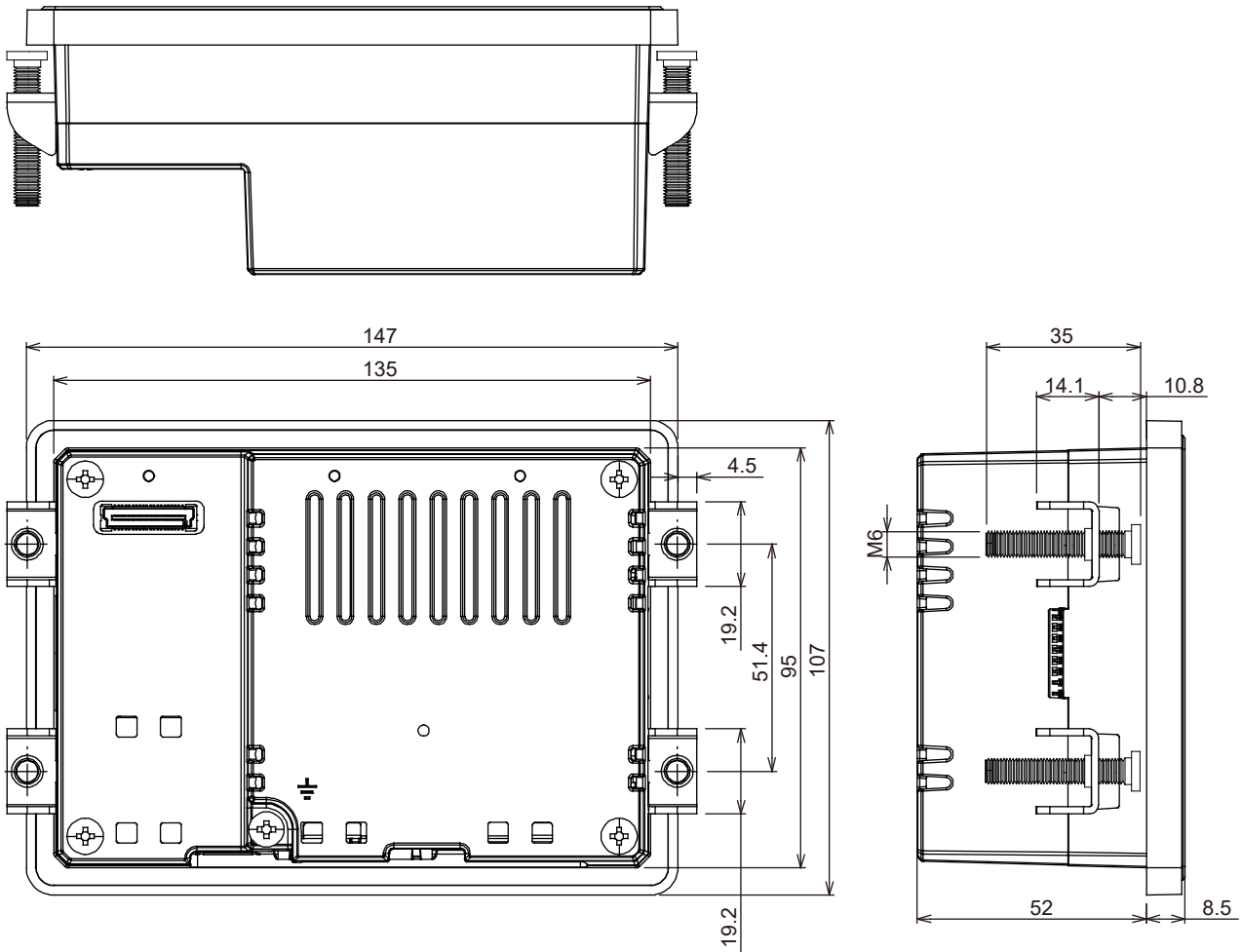

Unit: mm  
 Tolerance (except T):  $\pm 1$   
 T Tolerance:  $\pm 0.5$



4.3.2 AWHA1C070

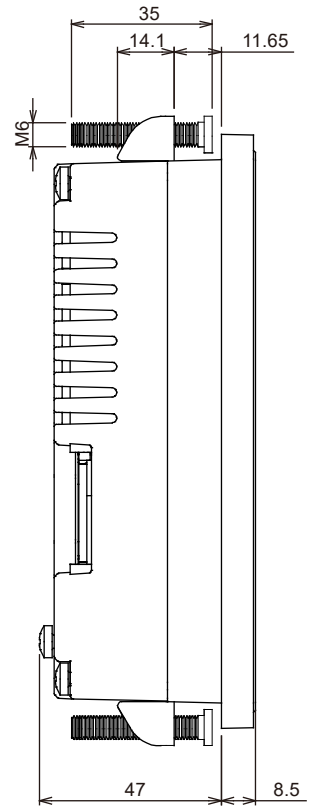
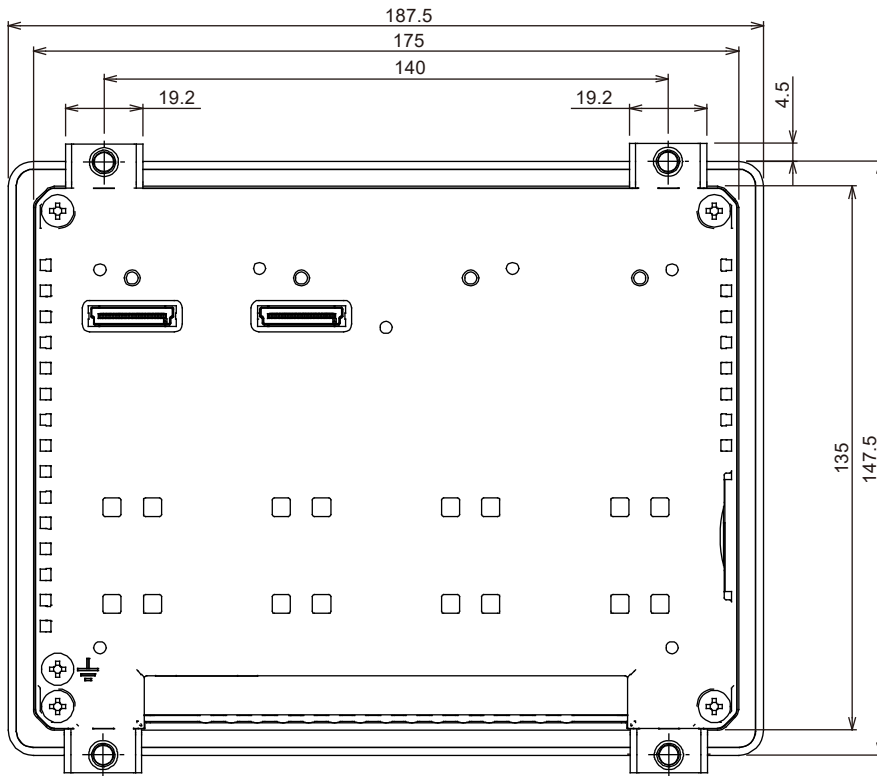
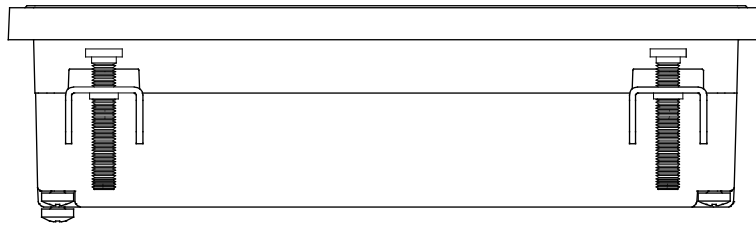

Unit: mm  
 Tolerance (except T):  $\pm 1$   
 T Tolerance:  $\pm 0.5$

4.3.3 AWHA1C101

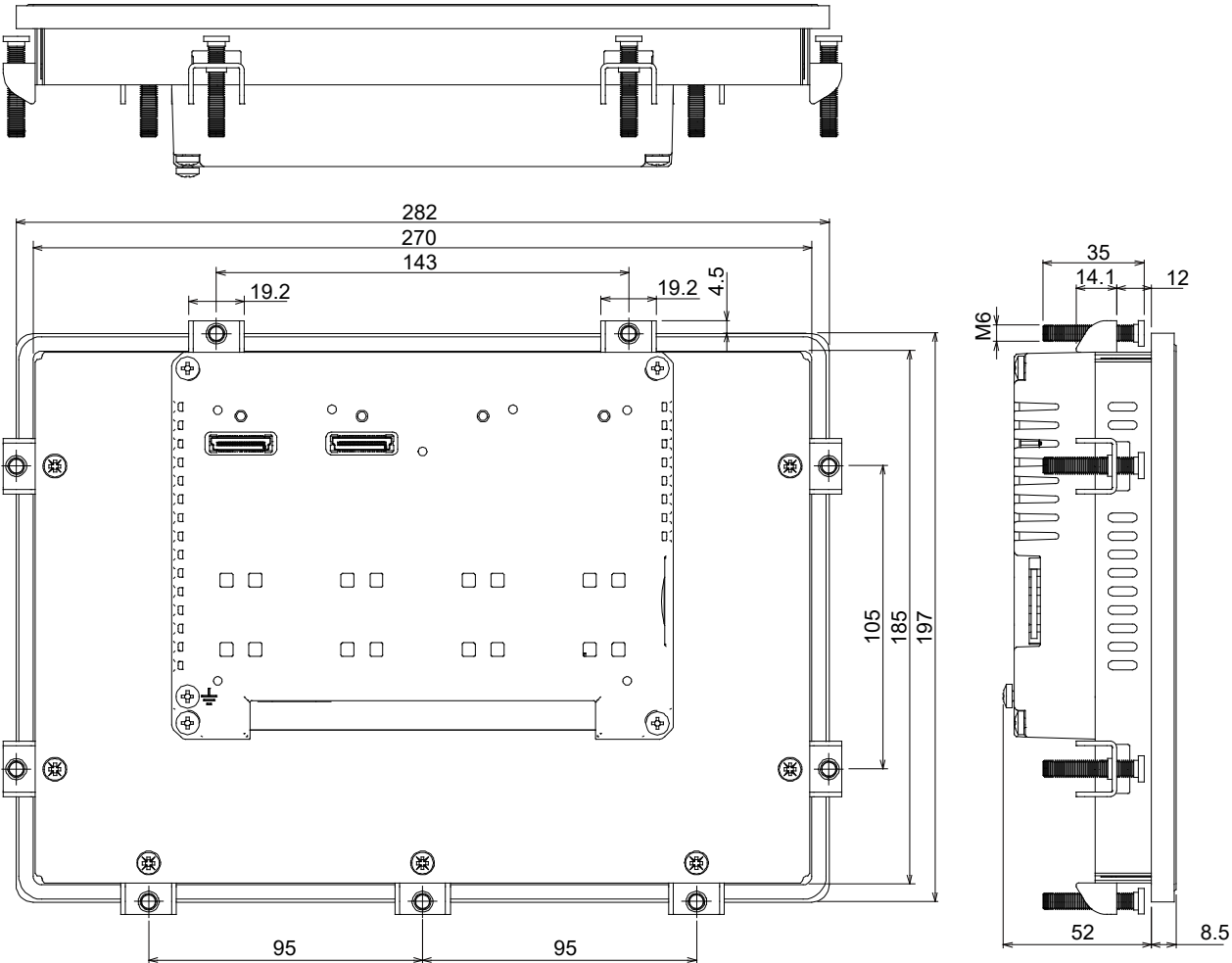

Unit: mm  
Tolerance (except T):  $\pm 1$   
T Tolerance:  $\pm 0.5$

4.3.4 AWAH1C156

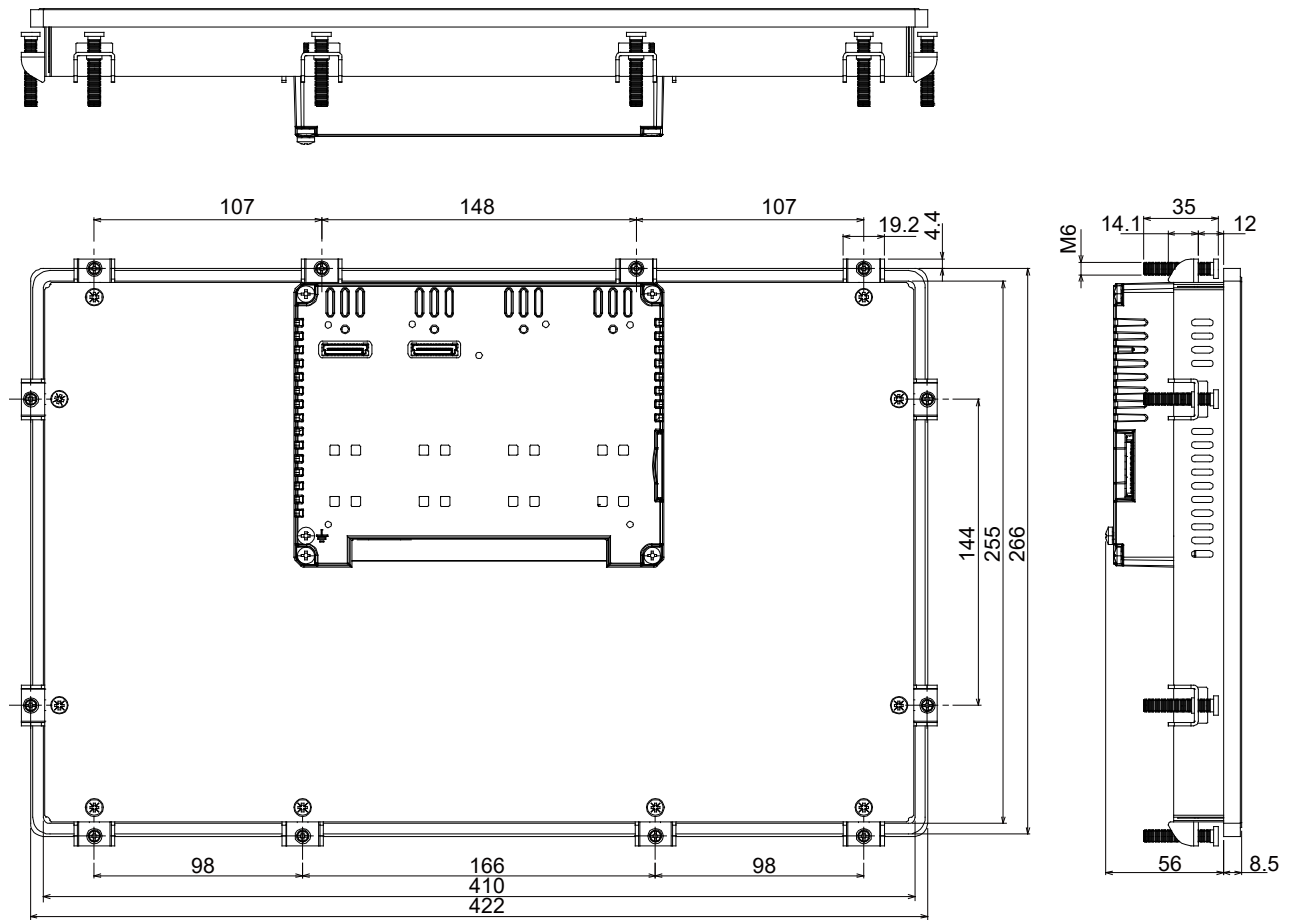

Unit: mm  
 Tolerance (except T):  $\pm 1$   
 T Tolerance:  $\pm 0.5$

4.3.5 AWHA1C215

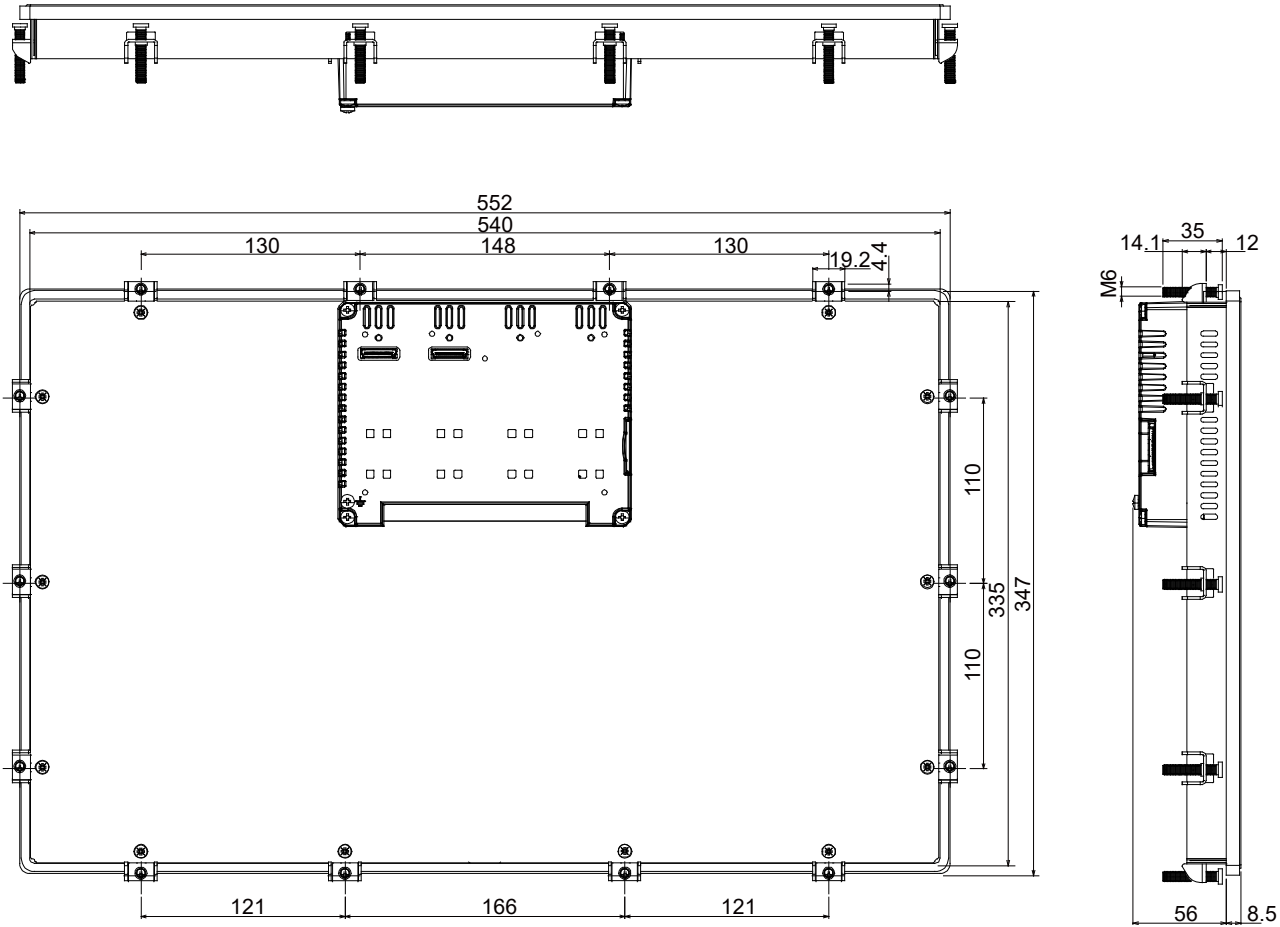

Unit: mm  
Tolerance (except T):  $\pm 1$   
T Tolerance:  $\pm 0.5$

## 5 System Settings

---

For more information, refer to the xAscender Studio User's Manual (Basic). The products must be programmed with the software xAscender Studio.

When the product is first started, the following image will be displayed.

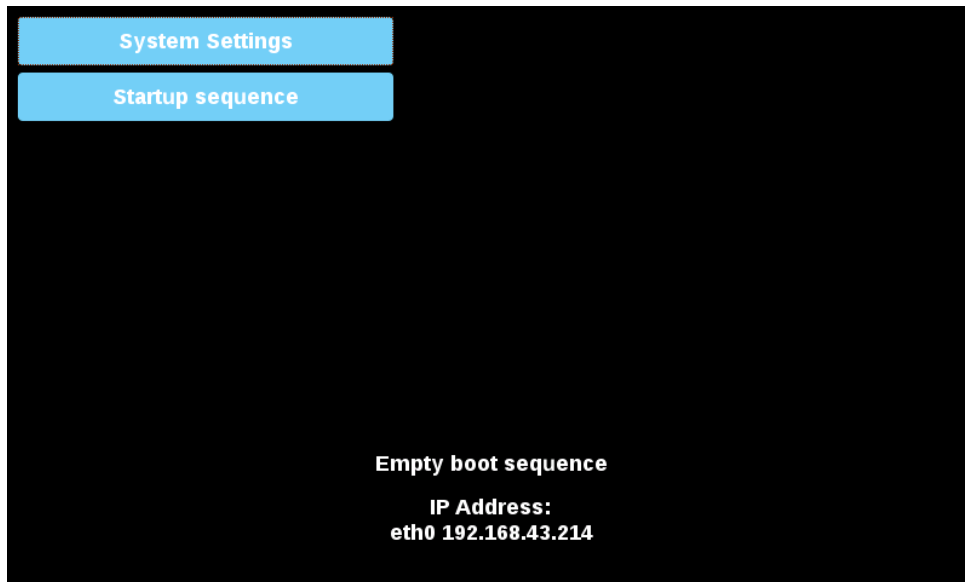

You need to install the xAscender HMI Runtime.

The installation is done simultaneously with the transfer of the application project created by xAscender Studio.

There are two options to transfer a xAscender Studio application project to a HMI device:

**Ethernet:** Connect the HMI device to the computer with an Ethernet. From xAscender Studio select the menu "Run" > "Download to target". You may have to ensure that the proper firewall policy has been configured in the computer to allow xAscender Studio to access the network.

**USB:** Create an Update Package using xAscender Studio and copy it from the USB memory to this product.

### Update System Components

The system components of the device can update locally using a USB memory key or remotely via web browser. To update system components enter System Settings in Config OS mode via tap-tap procedure on HMI or open web browser to [https://<HMI-IP-address>/machine\\_config](https://<HMI-IP-address>/machine_config) and select the “Management” section.

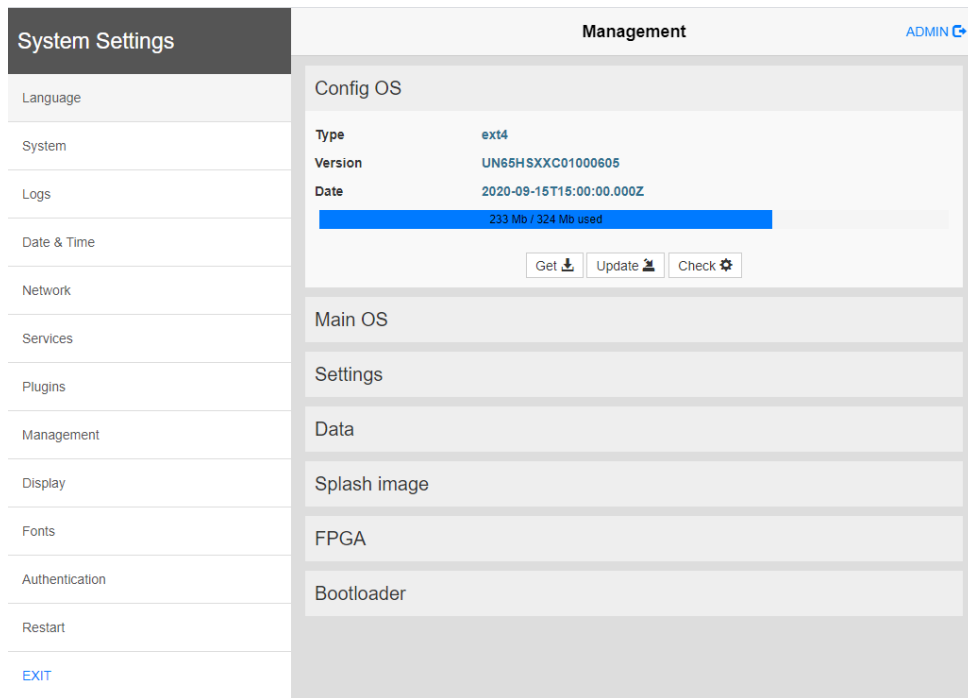

Expand the component to update and select [Update]

On the opened dialog, click [Browse Image], then select the “xxx-mainos-xxx.tar.gz” file. Click then on [Browse MD5] and select the “xxx-mainos-xxx.tar.gz.md5” file.

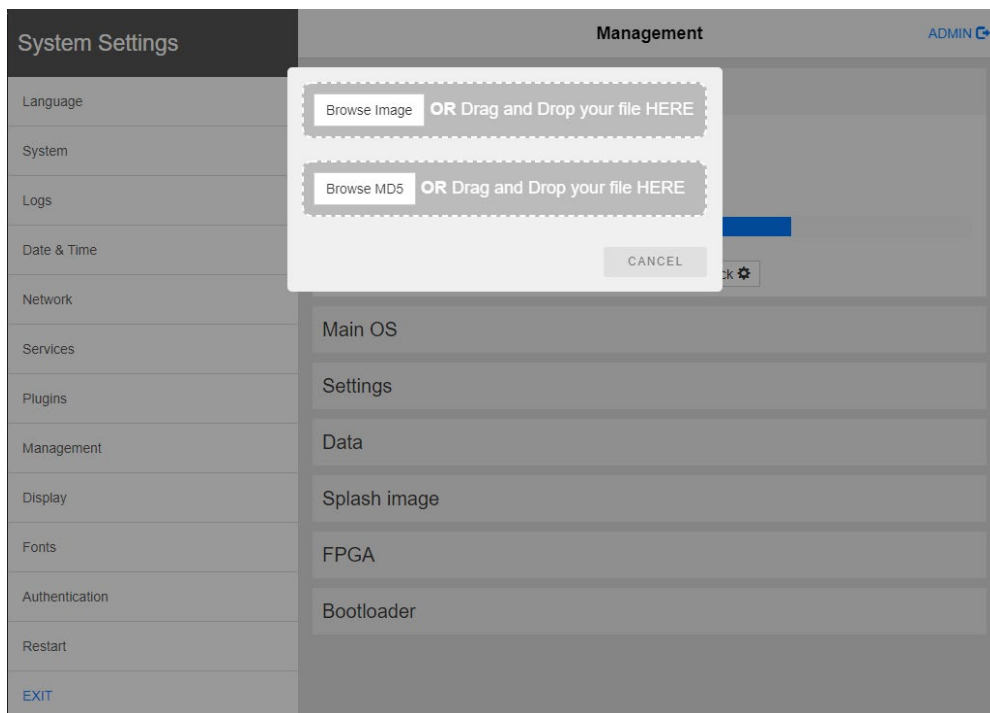

At the end of the component update, restart HMI and leave it starting normally.

The products have a system settings interface to allow configuration of system options. The user interface of System Settings is based on HTML pages accessible from the HMI screen or remotely using a Web browser Chrome v44 or higher using port 443. To connect enter the address https://IP/machine\_config where IP is the IP address of the HMI device. Default username is “admin”, default password is “admin”. Use navigation menu on the left side of the screen to browse through the available options.

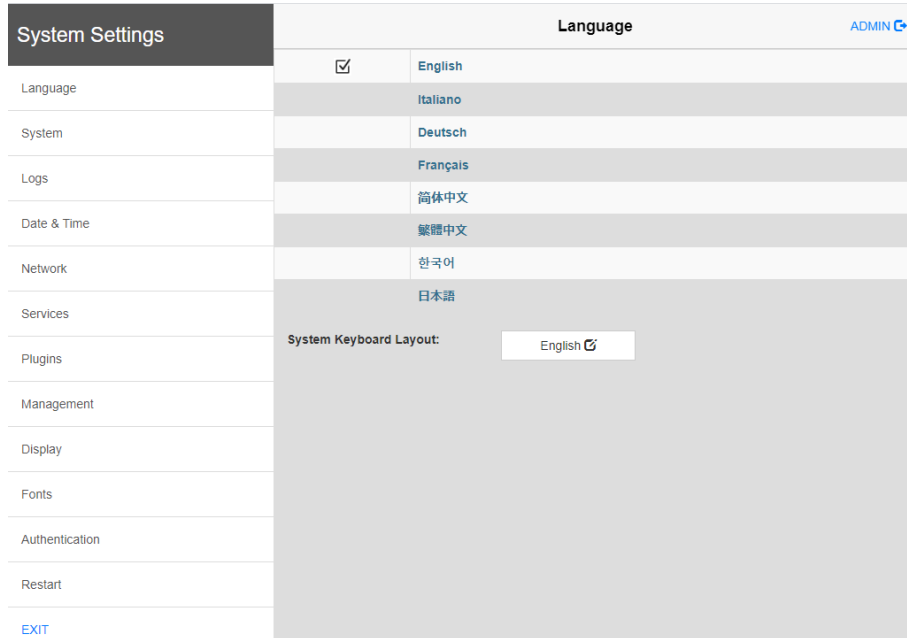

The right side shows related information and settings. Depending on the size of the HMI screen, both menu and content of selected item may be shown on screen at the same time or not.

**System Settings has two modes of operation:**

- User Mode: xAscender HMI Runtime is running or the HMI device is in “factory default” status.
- System Mode: xAscender HMI Runtime is not running or the HMI device has a software failure. System Mode includes all options available in User Mode and additionally includes commands dedicated to system upgrade and recovery not available when running in User Mode.

**Activation of System Settings in User Mode:**

- xAscender HMI Runtime not running: Press “System Setting” button on the HMI screen
- xAscender HMI Runtime running: Recall context menu and select “System Settings”. To recall the context menu click and hold any unused area of the touchscreen for a few seconds. Default hold time is 2 seconds.

## Activation of Systems Settings in System Mode:

Normal operation:

If xAscender HMI Runtime is not running:

Press "System Setting" button on the HMI screen to enter in System Settings in User Mode. Select "Restart" -> "Config OS" to reboot in System Mode.

If xAscender HMI Runtime is running:

Recall context menu and select "System Settings". To recall the context menu click and hold any unused area of the touchscreen for a few seconds. Default hold time is 2 seconds to enter in System Settings in User Mode. Select "Restart" -> "Config OS" to reboot in System Mode.

Recovery operation:

If panel is not responsive:

Use the so-called "tap-tap" procedure. This procedure consists in tapping the surface of the touchscreen during the device power-up phase. Tapping frequency must be high. You have to start tapping the touchscreen as soon as power has been applied to the device. When the sequence has been recognized, the system shows the message:

"TAP-TAP DETECTED". At this point, release the touch to boot in User Mode without running xAscender HMI Runtime or press and hold for a few seconds (selecting "RESTART: CONFIG OS") to boot in System Mode.

## System Settings includes options for basic settings of the device.

Language	Configure language used for System Setting menu only.
System	Show informations about platform, status and timers (like System on time, backlight on time).
Logs	Enable persistent log for BSP and allows exporting it.
Date & Time	Change the device date and time, including time zone and NTP Server.
Network	Configure IP Address of Network interfaces and the network settings like DNS, Gateway, DHCP, Host name.
Services	Enable/disable services. Example of services are Cloud Services, SNMP Server.
Plugins	Not supported.
Management	Update of components (Main OS, Config OS, Boot Loader), check for partitions consistence, update of splash screen, information about usage and size of partitions. Main OS and Config OS updates are supported only in system mode.
Display	Adjust display brightness, configure automatic backlight turnoff and select HMI orientation (90°, 180°, 270° and 360°).
Fonts	Display the supported fonts. Import custom fonts.
Authentication	Configure password for administrator ("admin") and for the standard user ("user"). Administrator has full access to System Settings. Standard user has some limitations.
Restart	Main OS restarts by default, and "Config OS" restarts in system mode directly on the panel.
EXIT	Exit from the System Setting tool.



## Revision History

Manual no.	Date.	Record of Changes
WUME-WHA1-01	Dec.2020	1st edition
WUME-WHA1-02	Sep. 2022	2nd edition: Described methods to connect to the Ethernet ports. Corrected the manual code. Corrected status indicators of Ethernet ports Listed chemicals the panel front surface can resist. Corrected companies which have the registered trademark for Ethernet.
WUME-WHA1-03	Nov. 2023	3rd edition: Installation dimensions drawing is shown.
WUME-WHA1-04	Apr. 2024	4rd edition: Change in Corporate name EU Directive applicable standard delete

## Order Placement Recommendations and Considerations

The Products and Specifications listed in this document are subject to change (including specifications, manufacturing facility and discontinuing the Products) as occasioned by the improvements of Products. Consequently, when you place orders for these Products, Panasonic Industry Co., Ltd. asks you to contact one of our customer service representatives and check that the details listed in the document are commensurate with the most up-to-date information.

### [Safety precautions]

Panasonic Industry Co., Ltd. is consistently striving to improve quality and reliability. However, the fact remains that electrical components and devices generally cause failures at a given statistical probability. Furthermore, their durability varies with use environments or use conditions. In this respect, check for actual electrical components and devices under actual conditions before use. Continued usage in a state of degraded condition may cause the deteriorated insulation. Thus, it may result in abnormal heat, smoke or fire. Carry out safety design and periodic maintenance including redundancy design, design for fire spread prevention, and design for malfunction prevention so that no accidents resulting in injury or death, fire accidents, or social damage will be caused as a result of failure of the Products or ending life of the Products.

The Products are designed and manufactured for the industrial indoor environment use. Make sure standards, laws and regulations in case the Products are incorporated to machinery, system, apparatus, and so forth. With regard to the mentioned above, confirm the conformity of the Products by yourself.

Do not use the Products for the application which breakdown or malfunction of Products may cause damage to the body or property.

- i) usage intended to protect the body and ensure security of life
- ii) application which the performance degradation or quality problems, such as breakdown, of the Products may directly result in damage to the body or property

It is not allowed the use of Products by incorporating into machinery and systems indicated below because the conformity, performance, and quality of Products are not guaranteed under such usage.

- i) transport machinery (cars, trains, boats and ships, etc.)
- ii) control equipment for transportation
- iii) disaster-prevention equipment / security equipment
- iv) control equipment for electric power generation
- v) nuclear control system
- vi) aircraft equipment, aerospace equipment, and submarine repeater
- vii) burning appliances
- viii) military devices
- ix) medical devices (except for general controls)
- x) machinery and systems which especially require the high level of reliability and safety

### [Acceptance inspection]

In connection with the Products you have purchased from us or with the Products delivered to your premises, please perform an acceptance inspection with all due speed and, in connection with the handling of our Products both before and during the acceptance inspection, please give full consideration to the control and preservation of our Products.

### [Warranty period]

Unless otherwise stipulated by both parties, the warranty period of our Products is three years after the purchase by you or after their delivery to the location specified by you. The consumable items such as battery, relay, filter and other supplemental materials are excluded from the warranty.

### [Scope of warranty]

In the event that Panasonic Industry Co., Ltd. confirms any failures or defects of the Products by reasons solely attributable to Panasonic Industry Co., Ltd. during the warranty period, Panasonic Industry Co., Ltd. shall supply the replacements of the Products, parts or replace and/or repair the defective portion by free of charge at the location where the Products were purchased or delivered to your premises as soon as possible.

However, the following failures and defects are not covered by warranty and we are not responsible for such failures and defects.

- (1) When the failure or defect was caused by a specification, standard, handling method, etc. which was specified by you.
- (2) When the failure or defect was caused after purchase or delivery to your premises by an alteration in construction, performance, specification, etc. which did not involve us.
- (3) When the failure or defect was caused by a phenomenon that could not be predicted by the technology at purchasing or contracted time.
- (4) When the use of our Products deviated from the scope of the conditions and environment set forth in the instruction manual and specifications.
- (5) When, after our Products were incorporated into your products or equipment for use, damage resulted which could have been avoided if your products or equipment had been equipped with the functions, construction, etc. the provision of which is accepted practice in the industry.
- (6) When the failure or defect was caused by a natural disaster or other force majeure.
- (7) When the equipment is damaged due to corrosion caused by corrosive gases etc. in the surroundings.

The above terms and conditions shall not cover any induced damages by the failure or defects of the Products, and not cover your production items which are produced or fabricated by using the Products. In any case, our responsibility for compensation is limited to the amount paid for the Products.

### [Scope of service]

The cost of delivered Products does not include the cost of dispatching an engineer, etc. In case any such service is needed, contact our sales representative.

**Panasonic Industry Co., Ltd.**



---

## Panasonic Industry Co., Ltd.

1006, Oaza Kadoma, Kadoma-shi, Osaka 571-8506, Japan  
<https://industry.panasonic.com/>

Please visit our website for inquiries and about our sales network.

© Panasonic Industry Co., Ltd. 2020-2024

April, 2024

WUME-WHA1-04