

**IO-Link Communication Unit for SF4D Series**

**SFD-WL3**



CME-SFDWL3 No.0070-81V

Thank you very much for purchasing this Panasonic product. Please read this Instruction Manual carefully and thoroughly for the correct and optimum use of this product. Kindly keep this manual in a convenient place for quick reference.

- This manual explains about the function of this product and its connection method. Using its IO-Link communication function, the product allows confirmation of the settings of a light curtain (SF4D series) as a host. It can also store the setting data of the connected light curtain.
- For the detailed instructions for the light curtain to be connected to this product, visit our website (<https://panasonic.net/id/pidsx/global>).

**1 SAFETY PRECAUTIONS** Always observe

- This section explains important rules that must be observed to prevent human injury and property damage.
  - The hazards that may occur if the product is used incorrectly are described and classified by level of harm.

<b>⚠ WARNING</b>	Risk of death or serious injury
<b>⚠ CAUTION</b>	Risk of minor injury or property damage.

- Use this device as per its specifications. Do not modify this device since its functions and capabilities may not be maintained and it may malfunction.
- This device has been developed / produced for industrial use only.
- This product is suitable for indoor use only.
- Use of this device under the following conditions or environments is not presupposed. Please consult us if there is no other choice but to use this device in such an environment.
  - 1) Operating this device under conditions or environments not described in this manual.
  - 2) Using this device in the following fields: nuclear power control, railroad, aircraft, auto mobiles, combustion facilities, medical systems, aerospace development, etc.
- Note that this device may be damaged if it is subject to a strong shock (if it is dropped onto the floor, for example).
- In case of disposal, dispose this device as an industrial waste.

**⚠ WARNING**

- ♦ **Do not use the IO-Link data for safety control.**
- ♦ **Machine designer, installer, employer and operator**
  - The machine designer, installer, employer and operator are solely responsible to ensure that all applicable legal requirements relating to the installation and the use in any application are satisfied and all instructions for installation and maintenance contained in the instruction manual are followed.
  - Whether this device functions as intended to and systems including this device comply with safety regulations depends on the appropriateness of the application, installation, maintenance and operation. The machine designer, installer, employer and operator are solely responsible for these items.
- ♦ **Engineer**
  - The engineer would be a person who is appropriately educated, has widespread knowledge and experience, and can solve various problems which may arise during work, such as a machine designer, installer or employer etc.
- ♦ **Operator**
  - The operator should read this instruction manual thoroughly, understand its contents, and perform operations following the procedures described in this manual for the correct operation of this device.
  - In case this device does not perform properly, the operator should report this to the employer and stop the machine operation immediately. The machine must not be operated until correct performance of this device has been confirmed.
- ♦ **Environment**
  - Do not use a mobile phone or a radio phone near this device.
  - Do not install this device in the following places.
    - 1) A location exposed to direct sunlight
    - 2) A location where condensation may form due to sudden changes of temperature
    - 3) A location where there are corrosive or combustible gases
    - 4) A location with significant dirt, metal powder, or salt
    - 5) A location where organic solvents such as benzene, paint thinner or alcohol, or strong alkaline substances such as ammonia or caustic soda, may come in contact with the device or are present in the air.
    - 6) A location with significant steam or dust, a location subject to vibration or shock, or a location where water droplets may come into contact with the device.
    - 7) A location near high-voltage lines, high-voltage equipment, power lines, power equipment, equipment with an amateur radio transmitter, or equipment that generates large switching surges (minimum 100mm)
- ♦ **Light curtain setting information copy function**
  - Use the copy function only when replacing the light curtain. If you write to non-replacement parts, it may not operate safety function properly.
  - To prevent misoperations by third parties, always implement the following countermeasures.
    - 1) Design to restrict send command on the IO-Link side.
    - 2) Use the communication module **SF4D-TM1** (option) and Configurator Light Curtain software to enable the protection function.
  - After copying the configuration to the light curtain after replacement, always verify of the safety function. If you do not check the operation and use it with incorrect settings, risk of impaired death or serious injury.
- ♦ **Other matters**
  - Never modify this device. Risk of impaired device functionality and death or serious injury.

**⚠ CAUTION**

- This product cannot be used to directly enter settings from the IO-Link master unit to a light curtain using IO-Link communication.

**2 STANDARDS / REGULATIONS**

- This product complies with the standards / regulations below.
  - <European Directives>
  - EMC Directive



**3 CONTENTS OF PACKAGE**

- Controller 1 pc.
- Quick Instruction Guide (Japanese, English) 1 pc. each.
- General Information for Safety, Compliance, and Instructions (23 languages) 1 pc.

**4 SYSTEM LAYOUT**

- This product is an IO-Link communication module that performs IO-Link communication when it is connected to a light curtain and IO-Link master unit.

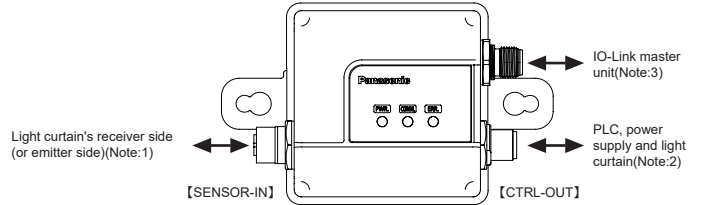

- Notes: 1) Only bottom cap cable with 8-core connector for SF4D Series light curtain or extension cable with 8-core connector on both ends for SF4D Series light curtain can be connected.  
 2) Only extension cable with 8-core connector on one end for SF4D Series light curtain or extension cable with 8-core connector on both ends for SF4D Series light curtain can be connected.  
 3) M12 4-core connector cable for IO-Link communication can be connected

**5 DESCRIPTION OF PARTS**

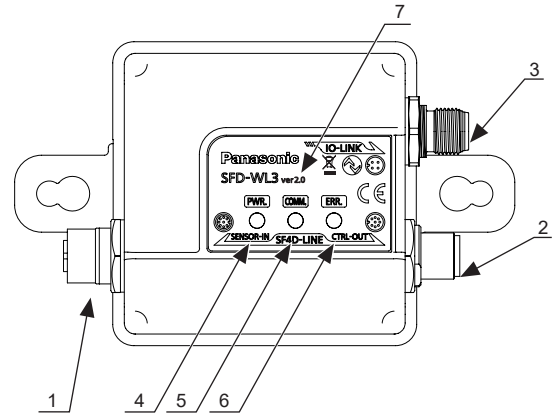

	Name	Function
1	8-core connector (socket) on light curtain communication side [SENSOR-IN]	Connection of 8-core connector cable (plug side) for connection of light curtain. Connection of light curtain's receiver (or emitter)
2	8-core connector (plug) on light curtain communication side [CTRL-OUT]	Connection of 8-core connector cable (socket side) for connection of light curtain. Connection of external device (PLC), power supply and light curtain's emitter (or receiver).
3	Connector (plug) on IO-Link communication side [IO-LINK]	Connection of IO-Link master unit (M12 connector).
4	Power indicator [PWR.]	Indication of the state of power supply to connectors on IO-Link communication side and light curtain side. (Notes:1)
5	Communication indicator [COMM.]	Indication of the state of IO-Link communication. (Notes:2)
6	Error indicator [ERR.]	Indication of error generation. (Notes:3)
7	Version	Version information of this product.

Notes: 1) The Power indicator lights in the following patterns.

	Connection state	
	IO-Link communication side	Light curtain side
Lights up	Connection	Connection
Flashes	Connection	Disconnected
OFF	Disconnected	(Irregular)

Notes: 2) The Communication indicator lights in the following patterns.

	IO-Link Communication states
Flashes	Communicating
OFF	Not communicating

Notes: 3) The Error indicator lights in the following patterns.

	Operating status
OFF	Normal operation
Lights up	IO-Link communication error
Flashes	Internal malfunction

**6 FUNCTIONS**

- The product connected to the IO-Link master unit enables monitoring the operation status of the connected light curtain (Please refer to "PROCESS DATA(PD)" and "SERVICE DATA(SD)" for monitoring items).
- This product stores the old (before replacement) light curtain setting data inside **SFD-WL3**, and copy setting data to the new (after replacement) light curtain after replacement.

Note )Writing is possible only for the same combination (model name,number and pitch of optical axis) of light curtain that got setting saving information.

## 7 INTERNAL CIRCUIT

### • Circuit Configurations

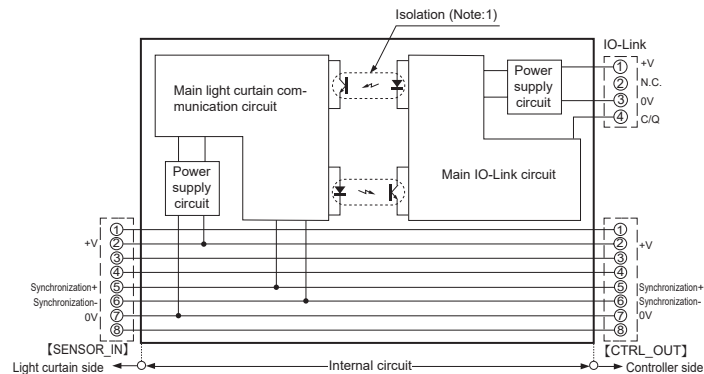

Note: 1) The main light curtain communication circuit is isolated from the main IO-Link circuit inside the product.

## 8 MOUNTING

- Observe the following tightening torque when installing the product: 5.5 N·m max. for M8 bolts or 2.5 N·m max. for M6 bolts. Mount the product using two bolts as shown in the diagram below.
- Mount the product in place before connecting connector cables.
- The product may be installed in any orientation or direction. Be sure to connect the cables securely to prevent communication errors resulting from loosening or detaching of cables or connectors due to its installation direction.

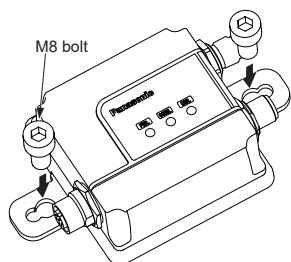

Using M8 bolts for installation  
(Use larger holes located toward the inside)

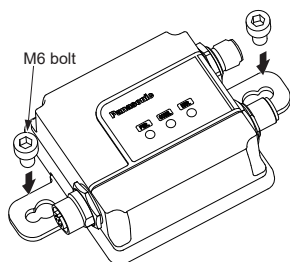

Using M6 bolts for installation  
(Use smaller holes located toward the outside)

## 9 CONNECTION

- Turn OFF the power to the light curtain and IO-Link master unit before connecting the product to the light curtain and IO-Link master unit.
- Various types of cable are available as optional parts for SF4D Series light curtains. For details, visit our website (<https://panasonic.net/id/pidsx/global>).

### Connection to light curtain

<When using the product by connecting it to the receiver side of light curtain >

- Connect the connector (plug side) on the 8-core bottom cap cable or 8-core extension cable connected to the light curtain's receiver to this product's 8-core connector (socket side) located on the light curtain communication side.

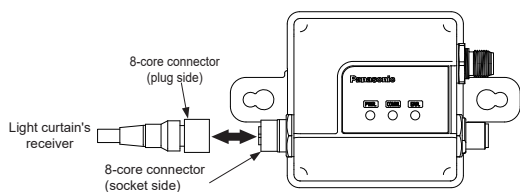

- Connect the connector (socket side) on the 8-core extension cable to this product's 8-core connector (plug side) on the light curtain communication side.

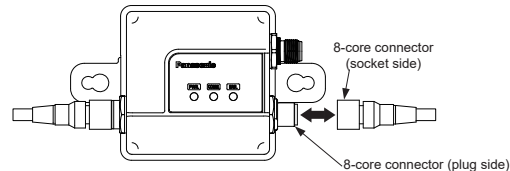

- Connect the 8-core extension cable connected in the above step 2 to the external device (PLC), power supply and light curtain's emitter.

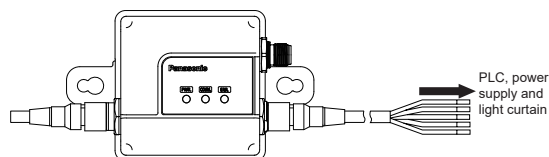

<When using the product by connecting it to the emitter side of light curtain >

- Connect the connector (plug side) on the 8-core bottom cap cable or 8-core extension cable connected to the light curtain's emitter to this product's 8-core connector (socket side) located on the light curtain communication side.

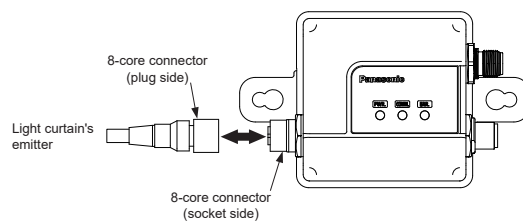

- Connect the connector (socket side) on the 8-core extension cable to this product's 8-core connector (plug side) on the light curtain communication side.

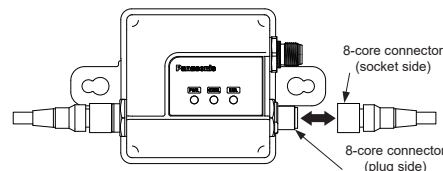

- Connect the 8-core extension cable connected in the above step 2 to the external device (PLC), power supply and light curtain's receiver.

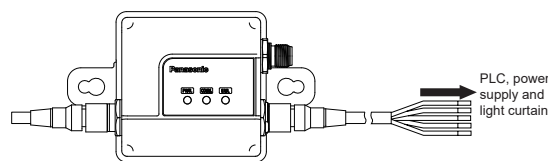

< Terminal layout of connector on light curtain communication side >



Terminal arrangement for connection of receiver side

Terminal No.	Functions
1	Control Output 2 (OSSD2)
2	24V DC
3	Control Output 1 (OSSD1)
4	External device monitor input
5	Synchronization +
6	Synchronization -
7	0V
8	Output polarity setting / Lockout release input

Terminals arrangement for connection of emitter side

Terminal No.	Functions
1	Interlock setting input
2	24V DC
3	Test / Reset input
4	Auxiliary output
5	Synchronization +
6	Synchronization -
7	0V
8	Output polarity setting / Lockout release input

### Connection to IO-Link master unit

Connect the M12 connector cable (optional) for communication with IO-Link master unit to this product's connector on the IO-Link communication side.

< Terminal arrangement of M12 connector type >

Terminal No.	Terminal Name	Functions
1	+V	Power +V
2	N.C.	-
3	0V	Power 0V
4	C/Q	IO-Link communication

• Recommended connection cable  
"A Coding" cable manufactured  
by TE Connectivity  
(IEC-61076-101)

## 10 LIGHT CURTAIN SETTING DATA COPY FUNCTION

- This function reads the setting data stored in the light curtain and copies it in the product's internal memory (nonvolatile memory). (You can not create and save data file for external back up.)
- When the light curtain is replaced during maintenance or for other reasons, the setting data stored in the product's internal memory can be written to the newly installed light curtain. This facilitates the setting work and also prevents setting errors.

Note ) This function cannot be used unless the product is connected with the IO-Link master unit and is able to use IO-Link communication. For detailed information, see [SERVICE DATA(SD)].

## 11 SPECIFICATIONS

Product name		IO-Link Communication Unit for <b>SF4D</b> Series
Model No.		<b>SFD-WL3</b>
Communication method	Light curtain communication side	RS-485 bidirectional communication (dedicated protocol)
	IO-Link communication side	IO-Link specifications: Ver. 1.1
Supply voltage	Light curtain communication side	24V DC $\begin{smallmatrix} +20 \\ -30 \end{smallmatrix}$ % Ripple P-P10% or less
	IO-Link communication side	24V DC $\begin{smallmatrix} +20 \\ -25 \end{smallmatrix}$ % Ripple P-P10% or less
Power consumption	Light curtain communication side	15mA or less
	IO-Link communication side	30mA or less
Functions		<ul style="list-style-type: none"> <li>IO-Link communication function</li> <li>Light curtain setting data copy function (Notes:1)</li> </ul>
Number of light curtain units in series connection		5 units (total number of light beams: 256 or less)
Protective structure		IP64
Over voltage category		I
Pollution Degree		3
Operating altitude		2000m or less (Notes:2)
Ambient temperature		-10 to +55°C (No dew condensation or icing allowed), Storage: -25 to +60°C
Ambient humidity		30 to 85% RH, Storage: 30 to 95% RH
Connection method	Light curtain communication side	8-core cable (with M12 connector) for light curtain
	IO-Link communication side	4-core cable (with M12 connector) (Notes:3)
Weight (main unit only)		Approx. 270g

- Notes: 1) The product's internal memory (nonvolatile memory) has a limited life. It cannot be used for more than 100,000 write operations.  
 2) Do not use or store the product in a high-pressure environment exceeding the atmospheric pressure at 0 m altitude.  
 3) The product and IO-Link master unit must be connected with a cable of 0.3 mm<sup>2</sup> or more. The total length of the cable must not exceed 20 m.  
 4) If the **SF4D** Ver.3.0 product is used with this product, restrictions will apply to the version of this product. When using the **SF4D** Ver. 3.0 product with this product, use this product of Ver.2.0 or later.

## 12 DIMENSIONS(Units: mm)

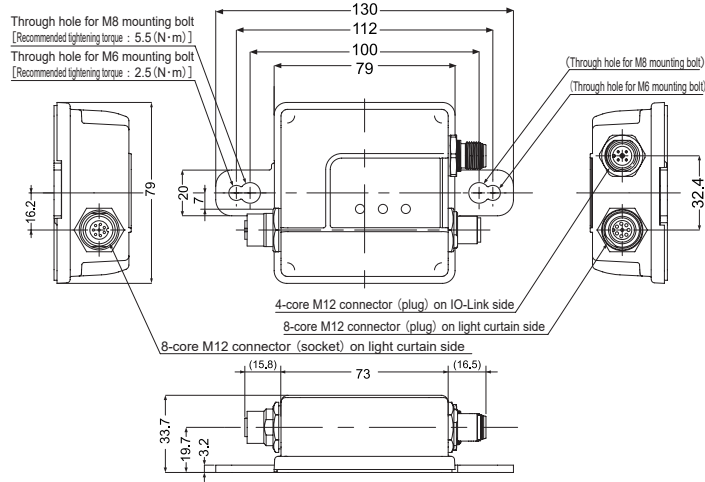

## 13 IO-LINK COMMUNICATION SPECIFICATIONS

IO-Link setting file (IODD) can be downloaded from our website ( <https://panasonic.net/id/pidsx/global> ).

Model No.	<b>SFD-WL3</b>
Baud rate	COM3(230.4kbps)
Minimum cycle time	1.5ms
Process data length	18byte
Vender ID	834
Device ID	0x050001

## 14 PROCESS DATA(PD)

Process data(Byte)																	
0	1	2	3	4	5	6	7	8	9	10	11	12	13	14	15	16	17
Reserved						CH5	CH4	CH3	CH2	CH1	General information						

Description of individual channel data(CH1-CH5)														Bit		Description	Detail	
7	6	5	4	3	2	1	0	7	6	5	4	3	2	1	0			
														Light received / blocked		0 : Light blocked 1 : Light received		
														Stable light reception information		0 : Unstable light reception 1 : Stable light reception		
														Unstable light reception information		0 : No unstable light reception 1 : Unstable light reception		
														Ambient light information		0 : No ambient light 1 : Ambient light detected		
														—		0		
														Emitter lockout detection		0 : Not exist 1 : Exist		
														Receiver lockout detection		0 : Not exist 1 : Exist		
														Light intensity information (Digital indicator)		00 : [OFF]    01 : [Level 1] 10 : [Level 2]    11 : [Level 3]		
														—		0		

General information														Bit		Description	Detail	
7	6	5	4	3	2	1	0	7	6	5	4	3	2	1	0			
														OSSD output monitor information		0 : OFF 1 : ON		
														—		0		
														Light curtain communication control state (Note)		0 : Normal 1 : Busy		
														Light curtain communication control result (Note)		0 : Normal 1 : Abnormal		
														Emitter linkage information		0 : Not connected 1 : Connected		
														Receiver linkage information		0 : Not connected 1 : Connected		
														Number of units in series connection		1 to 5 (0001~0101) ※ 0 : Not connect / 6~15 : Unused		
														—		0		

Note ) The light curtain communication control flag is for the light curtain setting information copy function.

# 15 SERVICE DATA(SD)

<Read Access>

Index	Sub index	Description	Format	Data length	Remarks		
16	0	Vendor Name	String	64byte			
17	0	Vendor Text	String	64byte			
18	0	Product Name	String	64byte			
19	0	Product ID	String	16byte			
20	0	Product Text	String	64byte			
21	0	Serial Number	String	8byte			
22	0	H/W Version	String	16byte			
23	0	F/W Version	String	16byte			
65	0	IO-Link device	Model Name	String	64byte		
66	0		Serial Number	String	8byte		
67	0		Version	String	16byte	Version information of the light curtain	
68	0		Error Code	UInteger	1byte	Latest error code (Notes:1)(Refer to manual of SF4D)	
71	0		Elapsed time	UInteger	6byte	Elapsed time (year/month/day/hour/minute/second) after light curtain ON, 1 byte each (Notes:2)	
73	0		CH1	Model Name	String	64byte	
74	0			Serial Number	String	8byte	
75	0			Version	String	16byte	Version information of the light curtain
76	0			Error Code	UInteger	1byte	Latest error code (Notes:1)(Refer to manual of SF4D)
79	0			Elapsed time	UInteger	6byte	Elapsed time (year/month/day/hour/minute/second) after light curtain ON, 1 byte each (Notes:2)
81	0	CH2	Model Name	String	64byte		
82	0		Serial Number	String	8byte		
83	0		Version	String	16byte	Version information of the light curtain	
84	0		Error Code	UInteger	1byte	Latest error code (Notes:1)(Refer to manual of SF4D)	
87	0		Elapsed time	UInteger	6byte	Elapsed time (year/month/day/hour/minute/second) after light curtain ON, 1 byte each (Notes:2)	
89	0		CH2	Model Name	String	64byte	
90	0			Serial Number	String	8byte	
91	0			Version	String	16byte	Version information of the light curtain
92	0			Error Code	UInteger	1byte	Latest error code (Notes:1)(Refer to manual of SF4D)
95	0			Elapsed time	UInteger	6byte	Elapsed time (year/month/day/hour/minute/second) after light curtain ON, 1 byte each (Notes:2)
97	0	CH3	Model Name	String	64byte		
98	0		Serial Number	String	8byte		
99	0		Version	String	16byte	Version information of the light curtain	
100	0		Error Code	UInteger	1byte	Latest error code (Notes:1)(Refer to manual of SF4D)	
103	0		Elapsed time	UInteger	6byte	Elapsed time (year/month/day/hour/minute/second) after light curtain ON, 1 byte each (Notes:2)	
105	0		CH3	Model Name	String	64byte	
106	0			Serial Number	String	8byte	
107	0			Version	String	16byte	Version information of the light curtain
108	0			Error Code	UInteger	1byte	Latest error code (Notes:1)(Refer to manual of SF4D)
111	0			Elapsed time	UInteger	6byte	Elapsed time (year/month/day/hour/minute/second) after light curtain ON, 1 byte each (Notes:2)
113	0	CH4	Model Name	String	64byte		
114	0		Serial Number	String	8byte		
115	0		Version	String	16byte	Version information of the light curtain	
116	0		Error Code	UInteger	1byte	Latest error code (Notes:1)(Refer to manual of SF4D)	
119	0		Elapsed time	UInteger	6byte	Elapsed time (year/month/day/hour/minute/second) after light curtain ON, 1 byte each (Notes:2)	
121	0		CH4	Model Name	String	64byte	
122	0			Serial Number	String	8byte	
123	0			Version	String	16byte	Version information of the light curtain
124	0			Error Code	UInteger	1byte	Latest error code (Notes:1)(Refer to manual of SF4D)
127	0			Elapsed time	UInteger	6byte	Elapsed time (year/month/day/hour/minute/second) after light curtain ON, 1 byte each (Notes:2)
129	0	CH5	Model Name	String	64byte		
130	0		Serial Number	String	8byte		
131	0		Version	String	16byte	Version information of the light curtain	
132	0		Error Code	UInteger	1byte	Latest error code (Notes:1)(Refer to manual of SF4D)	
135	0		Elapsed time	UInteger	6byte	Elapsed time (year/month/day/hour/minute/second) after light curtain ON, 1 byte each (Notes:2)	
137	0		CH5	Model Name	String	64byte	
138	0			Serial Number	String	8byte	
139	0			Version	String	16byte	Version information of the light curtain
140	0			Error Code	UInteger	1byte	Latest error code (Notes:1)(Refer to manual of SF4D)
143	0			Elapsed time	UInteger	6byte	Elapsed time (year/month/day/hour/minute/second) after light curtain ON, 1 byte each (Notes:2)
224	0	Light intensity information	CH1	UInteger	192byte		
225	0		CH2	UInteger	192byte	Light intensity information each optical axis, 1 byte (8 bits)	
226	0		CH3	UInteger	192byte	b7: Light received / blocked (0: Light blocked, 1: Light received)	
227	0		CH4	UInteger	192byte	b6: Rear ambient light information (0: No ambient light, 1: Ambient light detected)	
228	0		CH5	UInteger	192byte	b5: Front ambient light information (0: No ambient light, 1: Ambient light detected) b4 - b0: Light intensity information (32 levels)	

<Write Access>

Index	Sub index	Description	Format	Data length	Remarks	
240	1	Light curtain data access (Notes:3)	String	1byte	"R " :Light curtain setting data save (Notes:4) "W " :Stored light curtain setting data write (Notes:5)	
	2					
	3					
	4					
	5					
	16					
254	0	Light curtain restart	All CH	String	7byte	"RESTART" (Notes:6)

Notes: 1) If the light curtain fails to maintain normal communication status, the error code will not be displayed.

2) The elapsed time is the time from energization start to power shutdown of the light curtain (not cumulative time). The default display immediately after the start is [1(Year)/1(month)/1(day)/0(hour)/0(minute)/0(second)].

3) When light curtain information access is executed, OSSD outputs of the light curtain is fixed to OFF. Also, while the light curtain information is being accessed, the bit of the light curtain communication control state becomes "1" and other controls are not accepted. Do not turn off this product and the light curtain while accessing light curtain information. The setting information of the light curtain may be deleted.

4) Reads the data (blanking information and others) set in the light curtain and save it in the product's internal nonvolatile memory."R": Light curtain setting data save is possible only for all CH of "sub index \_16".

5) Writes the light curtain setting data stored in the product to the connected light curtain. After Writing, please confirm that there is no abnormality in the communication control result (PD).

[Note that the stored setting data can be written only when the configuration (model code, number of light beams, light beam pitch) of the new light curtain is the same as that of the previous light curtain.]

6) After executing the light curtain information access, execute the light curtain restart and cancel the OFF fixation of the OSSD outputs of the light curtain.

Panasonic Corporation

Panasonic Industrial Devices SUNX Co., Ltd.

<https://panasonic.net/id/pidsx/global>

Please visit our website for inquiries and about our sales network.

PRINTED IN JAPAN

© Panasonic Industrial Devices SUNX Co., Ltd. 2020