

Application Expansion Unit Exclusive for Light Curtain SF-C14EX

MJE-SFC14EX No.0077-91V

Thank you very much for purchasing Panasonic products. Please read this Instruction Manual carefully and thoroughly for the correct and optimum use of this product. Kindly keep this manual in a convenient place for quick reference. English and Japanese are original instructions.

1 SAFETY PRECAUTIONS

- This product has been developed / produced for industrial use only.
- Use this product as per its specifications. Do not modify this product since its functions and capabilities may not be maintained and it may malfunction.
- Use of this product under the following conditions or environments is not presupposed. Please consult us if there is no other choice but to use this product in such an environment.
 - 1) Operating this product under conditions or environments not described in this manual.
 - 2) Using this product in the following fields: nuclear power control, railroad, aircraft, automobiles, combustion facilities, medical systems, aerospace development, etc.
- When this product is to be used for enforcing protection of a person from any danger occurring around an operating machine, the user should satisfy the regulations established by national or regional security committees (Occupational Safety and Health Administration: OSHA, the European Standardization Committee, etc.). Contact the relative organization(s) for details.
- In case of installing this product to a particular machine, follow the safety regulations in regard to appropriate usage, mounting (installation), operation and maintenance. The users including the installation operator are responsible for the introduction of this product.
- Use this product by installing suitable protection equipment as a countermeasure for failure, damage, or malfunction of this product.
- Before using this product, check whether the product performs properly with the functions and capabilities as per the design specifications.
- In case of disposal, dispose this product as an industrial waste.

2 CAUTIONS

WARNING

- **Machine designer, installer, employer and operator**
 - The machine designer, installer, employer and operator are solely responsible to ensure that all applicable legal requirements relating to the installation and the use in any application are satisfied.
 - Whether this product functions as intended and systems including this product comply with safety regulations depends on the appropriateness of the application, installation and operation. The machine designer, installer, employer and operator are solely responsible for these items.
- **Engineer**
 - The engineer would be a person who is appropriately educated, has widespread knowledge and experience, and can solve various problems which may arise during work, such as a machine designer, or a person in charge of installation or operation, etc.
- **Operator**
 - The operator should read this instruction manual thoroughly, understand its contents, and perform operations following the procedures described in this manual for the correct operation of this product.
 - In case this product does not perform properly, the operator should report this to the person in charge and stop machine operation immediately. The machine must not be operated until correct performance of this product has been confirmed.
- **Environment**
 - Do not use a mobile phone or a radio phone near this product.
 - Do not install this product in the following environments.
 - 1) Areas with high humidity where condensation is likely to occur
 - 2) Areas exposed to corrosive or explosive gases
 - 3) Areas exposed to vibration or shock of levels higher than that specified
 - 4) Areas exposed to contact with water
 - 5) Areas exposed to too much steam or dust
- **Machine in which this product is installed**
 - Never use this product as a safety device for a press machine in Japan.
 - Do not install this product with a machine whose operation cannot be stopped immediately in the middle of an operation cycle by an emergency stop equipment.
 - This product starts the performance after 2 sec. from the power ON. Have the control system started to function with this timing.
- **Wiring**
 - Be sure to carry out the wiring in the power supply OFF condition.
 - All electrical wiring should conform to the regional electrical regulations and laws. The wiring should be done by engineer(s) having special electrical knowledge.
 - Do not run the wires together with high-voltage lines or power lines or put them in the same raceway. This can cause malfunction due to induction.

WARNING

- **Maintenance**
 - The periodical inspection of this product must be performed by an engineer having the special knowledge.
- **Others**
 - Never modify this product.
- When connecting this product to a product other than the connectable input device, the system does not conform to the control category 4 based on ISO 13849-1: 2015 (EN ISO 13849-1: 2015).
- Connect this product to the same power supply which the light curtain uses.
- Take care that wrong wiring will damage the product.
- Verify that the supply voltage variation is within the rating. Take care that if a voltage exceeding the rated range is applied, or if an AC power supply is directly connected, the product may get burnt or damaged.
- The DC power supply unit must satisfy the conditions given below:
 - 1) Power supply unit authorized in the region where this product is to be used.
 - 2) Power supply unit SELV (safety extra low voltage) / PELV (protected extra low voltage) conforming to EMC Directive and Low-voltage Directive (In case CE Marking conformity is required.)
 - 3) Power supply unit conforming to the Low-voltage Directive and with an output of 100VA or less.
 - 4) The frame ground (F.G.) terminal must be connected to ground when using a commercially available switching regulator.
 - 5) Power supply unit with an output holding time of 20ms or more.
 - 6) In case a surge is generated, take countermeasures such as connecting a surge absorber to the origin of the surge.
 - 7) Power supply unit corresponding to CLASS 2 (only for requiring cULus Mark conformation).
- This product is not dust-proof / splash proof. Be sure to put this product into a control box having IP54 construction.
- Avoid dust, dirt, and steam.
- Take care that the product does not come in contact with water, oil, grease, or organic solvents such as thinner, etc.
- The seal as shown in the drawing on the right is stuck to the engagement point of unit. If the seal is peeled off or broken, this product will not be certified as a "Safety equipment" and will not be covered by our guarantee.
- Note that this product is applicable only in the control circuit grounded in accordance with IEC 60204-1 and JIS B 9960-1, or in the control circuit in which the insulation monitor unit (ground fault detection unit) is arranged.
- This product is suitable for indoor use only.

Do not open!
If this seal is removed or damaged, the units are not recognized as safety product.
Panasonic Electric Works SUNX Co., Ltd.

3 OUTLINE

- This is the application expansion unit which can control three different safety outputs in combination with the light curtain. It exhibits the following features:
 - 1) Either PNP or NPN output can be selected with the slide switch.
 - 2) It can be connected to the light curtain using the exclusive 8-core connection cable with connectors.
 - 3) A detachable spring gauge terminal is employed.
 - 4) The three auxiliary outputs (muting output, override output and blown lamp output) and the auxiliary output of the light curtain are incorporated.
 - 5) The interference prevention wiring among the light curtains is possible. Maximumly three sets in series / parallel mixed connection can be configured with the interference prevention system. The number of total beam channels in series / parallel mixed connection is 192 max.
 - 6) The product enables to set each function using the handy controller **SFB-HC** (Ver. 2 or later) (optional). Refer to "**12 FUNCTIONS USING HANDY CONTROLLER SFB-HC (OPTIONAL)**."
- This device complies with the following standards / regulations.
 - <EU Directives>
EU Machinery Directive 2006/42/EC
EMC Directive 2014/30/EU
RoHS Directive 2011/65/EU
 - <European Standards>
EN 55011, EN IEC 63000, EN 61496-1 (Type 4)
EN ISO 13849-1: 2015 (Category 4, PLc)
 - <International Standards>
IEC 61496-1 (Type 4), ISO 13849-1: 2015 (Category 4, PLc)
 - <Japanese Industrial Standards (JIS)>
JIS B 9704-1 (Type 4), JIS B 9705-1 (Category 4)
 - <Standards in US / Canada>
ANSI/UL 61496-1 (Type 4), ANSI/UL 508, UL 1998 (Class 2)
CAN/CSA C22.2 No.14, CAN/CSA C22.2 No.0.8
 - <Regulations in US>
OSHA 1910.212, OSHA 1910.217(C), ANSI B11.1 to B11.19, ANSI/RIA 15.06
Regarding EU Machinery Directive, a Notified Body, TÜV SÜD, has certified with the type examination certificate.
With regard to the standards in US / Canada, a NRTL, UL (Underwriters Laboratories Inc.) has certified for cULus Listing Mark.

<Reference>
The conformity to JIS, OSHA and ANSI for this device has been evaluated by ourselves.

- The light curtains that can be used in combination with this product are as follows.
SF4B / SF4B<V2> series and **SF4B-□-01 / SF4B-□-01<V2>**

4 FUNCTIONAL DESCRIPTION

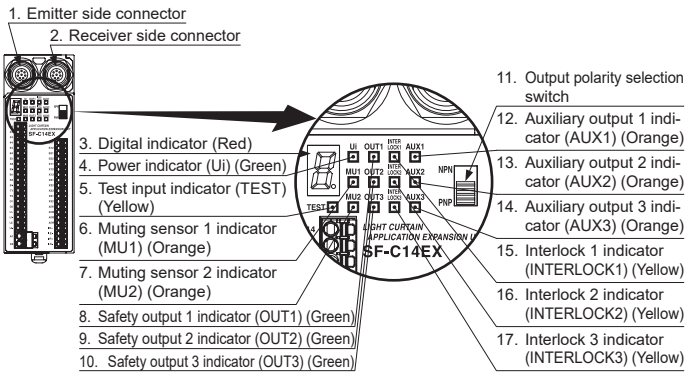

No.	Description	Function
1	Emitter side connector	Connects the emitter of the light curtain.
2	Receiver side connector	Connects the receiver of the light curtain.
3	Digital indicator (Red)	Lights up or blinks when an error occurs. Lights up when the blanking function is valid.
4	Power indicator (Ui) (Green)	Lights up when power is supplied.
5	Test input indicator (TEST) (Yellow)	Lights up when the test input is valid. Blinks when communicating with the handy controller SFB-HC .
6	Muting sensor 1 indicator (MU1) (Orange)	Lights up when muting sensor 1 is ON.
7	Muting sensor 2 indicator (MU2) (Orange)	Lights up when muting sensor 2 is ON.
8	Safety output 1 indicator (OUT1) (Green)	Lights up when safety output 1 is ON.
9	Safety output 2 indicator (OUT2) (Green)	Lights up when safety output 2 is ON.
10	Safety output 3 indicator (OUT3) (Green)	Lights up when safety output 3 is ON.
11	Output polarity selection switch	PNP (Minus earthing) or NPN (Plus earthing) can be selected. The factory setting is PNP (Minus earthing).
12	Auxiliary output 1 indicator (AUX1) (Orange)	Lights up when auxiliary output 1 is ON.
13	Auxiliary output 2 indicator (AUX2) (Orange)	Lights up when auxiliary output 2 is ON.
14	Auxiliary output 3 indicator (AUX3) (Orange)	Lights up when auxiliary output 3 is ON.
15	Interlock 1 indicator (INTERLOCK1) (Yellow)	Lights up when interlock 1 is ON.
16	Interlock 2 indicator (INTERLOCK2) (Yellow)	Lights up when interlock 2 is ON.
17	Interlock 3 indicator (INTERLOCK3) (Yellow)	Lights up when interlock 3 is ON.

5 TERMINAL ARRANGMENT

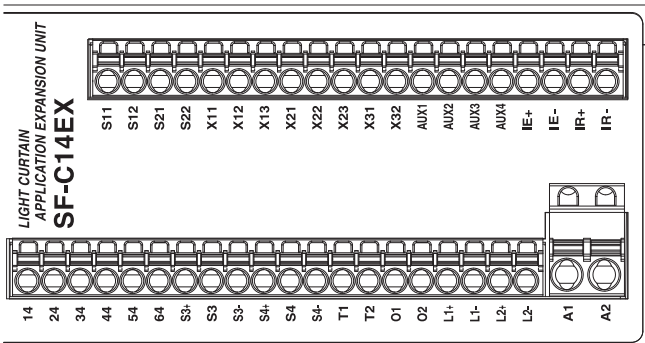

Terminal No.	Function	Terminal No.	Function
14	Safety output 1 Light received / blocked output of the light curtain	S11	Emergency stop contact input
24	Safety output 2 Light curtain output including the muting function	S12	2 NC input
34	Safety output 3	S21	Between S11 to S12
44	Emergency stop output	S22	Between S21 to S22
54	Muting sensor input 1 (PNP output type)	X11	Safety output 1 reset input
S3+	S3+, S3-: Power supply	X12	X11 to X12: Manual reset
S3-	S3: Sensor output	X13	X11 to X13: Auto-reset
S4+	Muting sensor input 1 (NPN output type)	X21	Safety output 2 reset input
S4-	S4+, S4-: Power supply	X22	X21 to X22: Manual reset
S4-	S4: Sensor output	X23	X21 to X23: Auto-reset
T1	Test input terminal	X31	Safety output 3 reset input
T2	Open: Test mode	X32	X31 to X32: Manual reset
O1	Short-circuit: Normal operation	AUX1	Auxiliary output 1 Muting output
O2	Open: Invalid, Short-circuit: Valid	AUX2	Auxiliary output 2 Override output
L1+	Muting indicator output 1	AUX3	Auxiliary output 3 Blown lamp output
L1-		AUX4	Auxiliary output 4 Light curtain auxiliary output
L2+	Muting indicator output 2	IE+	Interference prevention terminal Emission +
L2-		IE-	Interference prevention terminal Emission -
A1	24V DC	IR+	Interference prevention terminal Receipt +
A2	0V	IR-	Interference prevention terminal Receipt -

6 INSTALLATION POSITION / DIRECTION / METHOD

- Use the 35mm width DIN rail to install the unit.
- The installation position / direction is not basically limited.
- Please fix this product with the DIN rail stopper **MS-DIN-E** (optional) after installing the product on to the 35mm width DIN rail.
- Always install this product in a control panel having an IP54 or higher protective structure.

7 MOUNTING TERMINAL BLOCK

- When connecting to the terminal block, insert a solid wire or twisted wire (lead wire) with a ferrule (sleeve) terminal (please arrange separately) into the hole as shown in the figure at the right. The wire is locked when it is properly inserted. However, do not to pull the wire with excessive force, as this can cause a cable break.
- When connecting the twisted wire (lead wire) without a ferrule (sleeve), insert the wire to the innermost of the connecting hole while pressing the release button.
- When releasing the solid wire or the twisted wire (lead wire), pull the wire while pressing the release button.
- The following cables are recommended for power supply side connector and other connector.
Power supply side connector (A1 and A2): 0.2 to 2.5mm² (AWG 24 to 12)
Other connector: 0.2 to 1.5mm² (AWG 24 to 16)

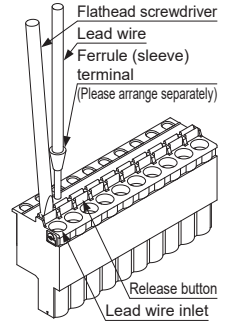

8 SHORT-CIRCUIT PROTECTION

- The power supply unit of this product adopts an electronic fuse which does not require any replacement.
- When the electronic fuse is operated, turn OFF the power supply, and remove the cause of overcurrent before restarting the power supply for resetting.
- The electronic fuse is not suitable to use in which the product is operated continuously or daily. Note that operating the product continuously may be unable to satisfy the specification.

9 WIRING

- When this product is connected to the light curtain, be sure to use the following connecting cable.
SFB-CB05-EX (cable length 0.5m), **SFB-CB5-EX** (cable length 5m)
SFB-CB10-EX (cable length 10m)
SFB-CCJ10E (for emitter, cable length 10m)
SFB-CCJ10D (for receiver, cable length 10m)
- The following cables are recommended for power supply side connector and other connector.
Power supply side connector (A1 and A2): 0.2 to 2.5mm² (AWG 24 to 12)
Other connector: 0.2 to 1.5mm² (AWG 24 to 16)
- Cable extension is possible up to 50m (for each emitter / receiver). However, 30m or less (for each emitter / receiver) for two sets in series connection, and 20m or less (for each emitter / receiver) for three sets in series connection.
Note that the cable cannot be extended for parallel connection.

<Wiring for PNP output (Manual reset)>

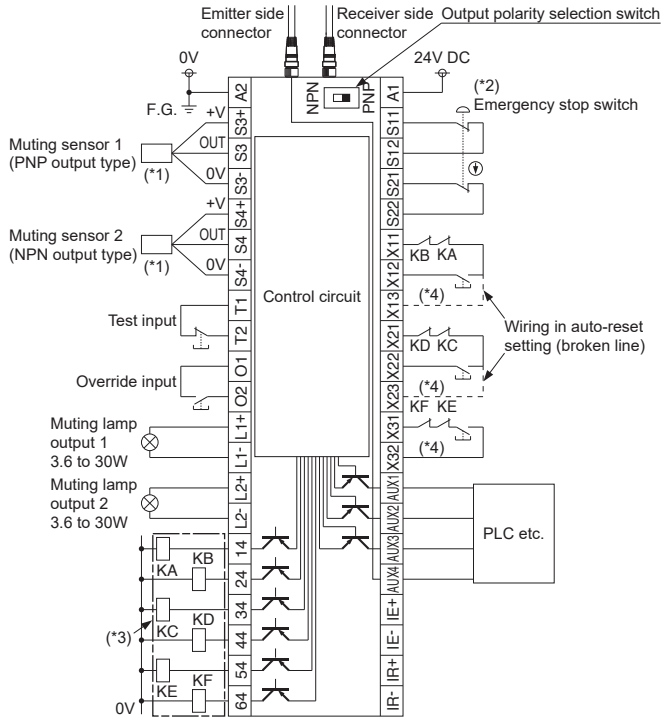

- *1: If the NO (Normally Open) contact switch is used as a muting sensor, wire it as shown in the figure right.
- *2: If the emergency stop switch is not used, short-circuit between the terminals S11 to S12 and S21 to S22 directly.
- *3: KA to KF are relays with forcibly guided contacts or magnet contractors.
- *4: Use a momentary-type switch for the reset button.

<Wiring for NPN output (Manual reset)>

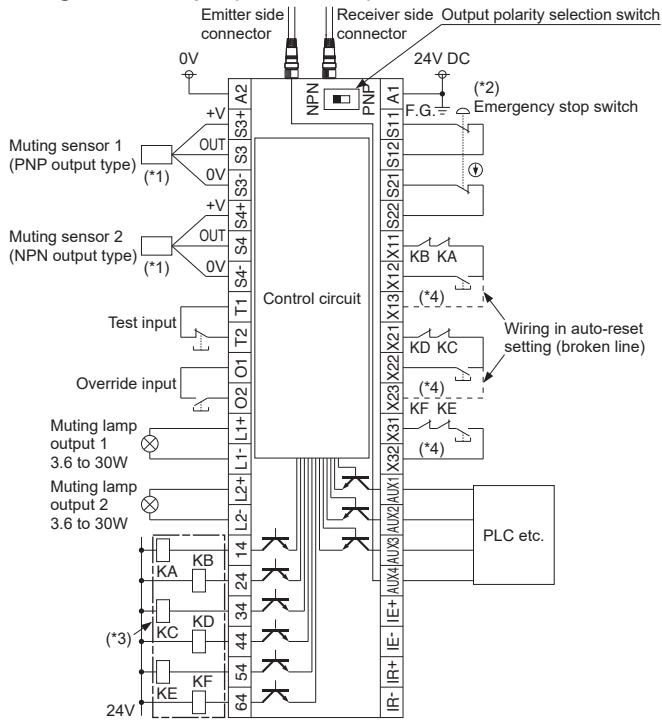

- *1: If the NO (Normally Open) contact switch is used as a muting sensor, wire it as shown in the figure right.
- *2: If the emergency stop switch is not used, short-circuit between the terminals S11 to S12 and S21 to S22 directly.
- *3: KA to KF are relays with forcibly guided contacts or magnet contractors.
- *4: Use a momentary-type switch for the reset button.

10 TIMING CHART

<Normal operation>

The diagram shows operation with safety outputs 1 / 2 in manual-reset mode.

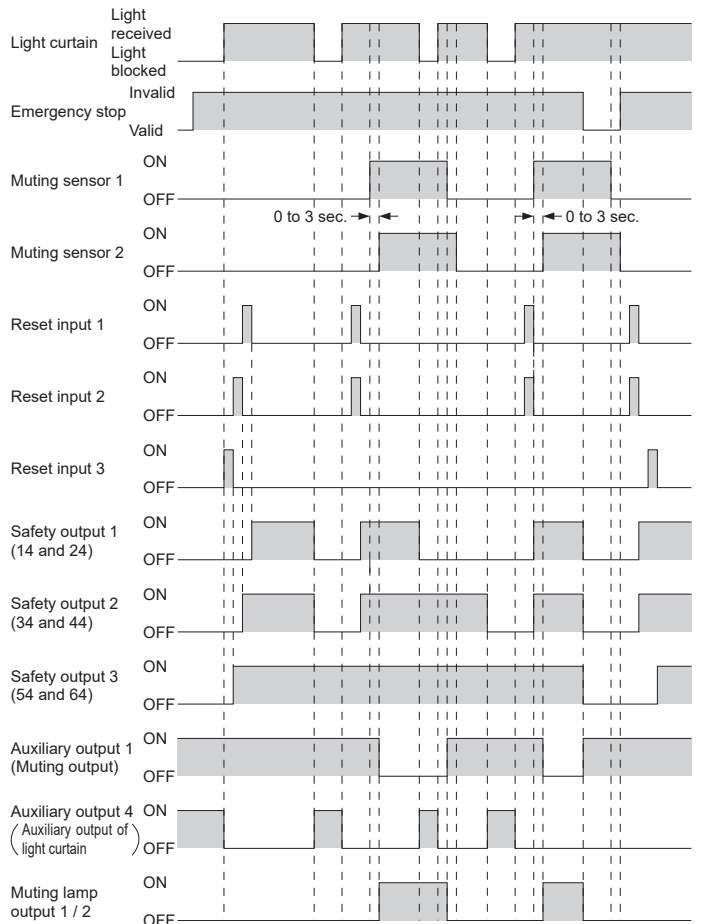

- The diagram above is the timing chart of this product in normal operation.
- In normal operation, auxiliary output 2 (override output) is maintained in the ON state.
- In normal operation, auxiliary output 3 (muting lamp output) is maintained in the ON state.
- Refer to "FUNCTIONS" for details of the muting function.

<Test input and Override input>

The diagram shows operation with safety outputs 1 / 2 in auto-reset mode.

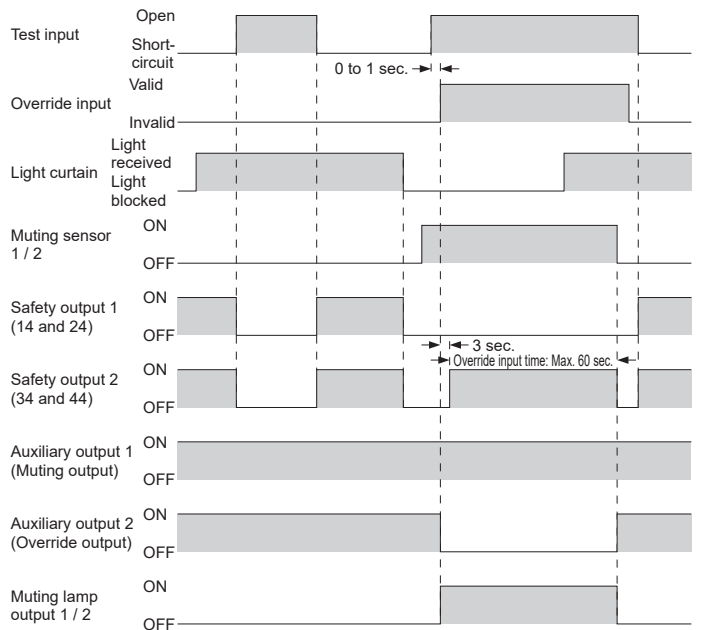

- Safety outputs 1 / 2 are OFF during test input.
- Refer to "FUNCTIONS" for details of the override function.

<Blown lamp output>

The diagram shows operation with safety outputs 1 / 2 in auto-reset mode.

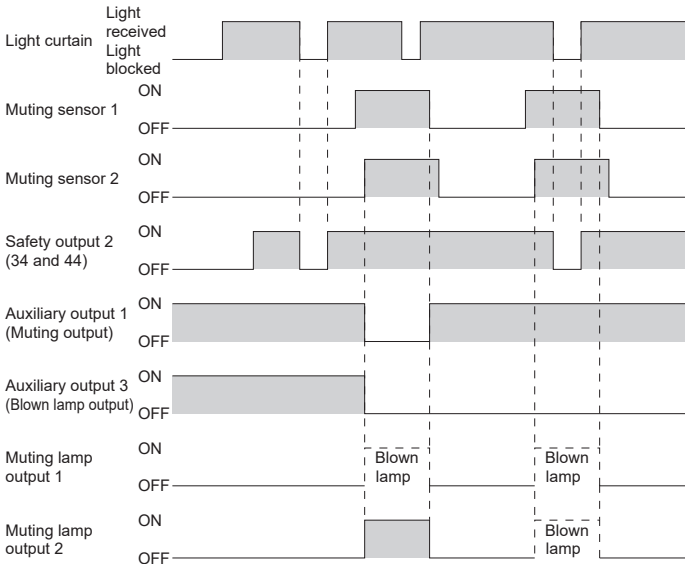

- The lamps are monitored during muting state, and if either of them blows, auxiliary output 3 is turned OFF. If only one lamp blows, the muting state is maintained, however, if both lamps blow, the muting state is canceled immediately.

11 FUNCTIONS

⚠ WARNING

- Incorrect using of the muting control may cause an accident. Please understand the muting control fully, and use it. As for the muting control, the following international standards define the requirements.
ISO 13849-1: 2015 (EN ISO 13849-1: 2015 / JIS B 9705-1) :
"Safety of machinery - Safety-related parts of control systems - Part 1: General principles for design, Article 5.9 Muting"
IEC 61496-1 (UL 61496-1 / EN 61496-1 / JIS B 9704-1) :
"Safety of machinery - Electro sensitive protective equipment - Part 1: General requirements and tests, Annex A, A.7 Muting"
IEC 60204-1 (JIS B 9960-1):
"Safety of machinery - Electrical equipment of machines - Part 1: General requirements, 9.2.4 Overriding safeguards"
EN 415-4:
"Safety of packaging machines - Part 4: Palletizers and depalletizers, Annex A, A2.2 Muting"
ANSI B11.19-1990:
"for Machine Tools-Safeguarding When Referenced by the Other B11 Machine Tool Safety Standards-Performance Criteria for the Design, Construction, Care, and Operation" 4.2.3 Presence-Sensing Devices: Electro-Optical and Radio Frequency (R.F.)
ANSI/RIA R15.06-1999:
"for Industrial Robots and Robot Systems - Safety Requirements, 10.4.5 Muting"
- Use the muting control while the machine cycle is not in danger mode. Maintain safety with the other measures while the muting control is activating.
- For the application that the muting control is activated when a workpiece passes through the sensor, place the muting sensor so that the conditions for muting control cannot be satisfied by intrusion of personnel when the workpiece is passing through the sensor or the workpiece is not passing through it.
- The muting lamp should be installed in a position where it can always be seen by operators who set or adjust the machine.
- Be sure to check the operation of the muting function before its use. Furthermore, check the state of the muting lamp (cleanliness, brightness, etc.)

• Reset operation

⚠ WARNING

Design the system such that the reset switch can be operated from outside the dangerous area, and also where the operators can see the entire dangerous area.

The reset function corresponding to the respective safety outputs 1 / 2 / 3 is incorporated.

X11, X12 and X13 terminal: Reset input terminal of safety output 1

When X11 and X12 terminals are used: Manual reset

When X11 and X13 terminals are used: Auto-reset

X21, X22 and X23 terminal: Reset input terminal of safety output 2

When X21 and X22 terminals are used: Manual reset

When X21 and X23 terminals are used: Auto-reset

X31 and X32 terminal: Reset input terminal of safety output 3

(Manual reset only).

However, if the muting function is valid, safety output 2 is not turned OFF.

• Safety output 1

This is the output corresponding to light curtain in light received / light blocked status.

In light received status: ON, In light blocked status: OFF

However, if the emergency stop is valid, safety output 1 is OFF.

• Safety output 2

This is the output corresponding to the light curtain in light received / light blocked status including the muting state.

In light received status or if the muting function is valid: ON,

In light blocked status and if the muting function is invalid: OFF

However, if the emergency stop is valid, the safety output 2 is OFF.

• Safety output 3

This is the output corresponding to the external emergency stop switch.

When the emergency stop is invalid: ON

When the emergency stop is valid: OFF

However, if the emergency stop is valid, both safety outputs 1 / 2 are OFF.

Note: When the safety output is ON, the output transistor goes OFF periodically to self-diagnose the output circuit. (OFF pulse width: 100µs or less) When the OFF signal is feedback, it is judged that the circuit works properly. When the OFF signal is not feedback, it is judged that the output circuit or wiring is in error and the safety output is maintained in the OFF state.

⚠ WARNING

Please consider the input response time of the machine to which you connect this product so that no malfunction occurs due to this product's OFF signal.

• Emergency stop

Safety output 3 can be controlled by connecting an external emergency stop switch or another interlock device.

*: Be sure to use a 2 NC type forcible dissociation type contact.

• Test input

⚠ WARNING

Do not use the test input function for the purpose of stopping the machine in which the light curtain is installed. Failure to do so could result in death or serious injury.

This function turns safety outputs 1 / 2 OFF forcibly.

Open between T1 and T2 terminals: Forcibly OFF.

Short-circuit between T1 and T2 terminals: Normal operation

This is used when the override function is used as well.

• Muting function

This function turns the safety output 2 into invalid temporarily. This function is available for passing the workpieces through the sensing area of the light curtain without stopping the machine.

The muting function becomes valid when all the conditions listed below are satisfied:

- The safety output 2 is ON.
- The incandescent lamp with 3.6 to 30W shall be connected to either muting lamp output 1 or 2, or to both of the inputs.
- The output of the muting sensors S3 and S4 shall be changed from OFF (open) to ON. At this time, the time difference occurred by changing the output of the muting sensors S3 and S4 into ON status shall be 0 to 3 sec.

• Muting sensor input

(Muting sensor is used in the "Dark-ON" state.)

This is used to connect the muting sensor. For following devices, photoelectric sensor with semiconductor output, inductive proximity sensor, position switch on NO (Normally Open) contacting point, etc. are available for applying to the muting sensor.

S3 terminal (S3+, S3 and S3-): 3-wire PNP open-collector type sensor

S4 terminal (S4+, S4 and S4-): 3-wire NPN open-collector type sensor

• Muting lamp

This lamp is used to show that the product is in muting state. Two lamps can be connected. Even if one of the two lamps breaks, the muting operation can be continued because of another lamp. The broken lamp can be replaced without suspending your work.

● **Override function**

⚠ WARNING

Design the system such that the test input and the override input can be manually operated from outside the dangerous area, and also where the operators can see the entire dangerous area.

This function forcibly turns the safety function into invalid. This function is used for the following cases: when the customer who uses the muting function needs to start the product with safety output 2 be OFF status, when the product is required to continue operating even though the muting sensor becomes valid after the muting sensor is turned ON at the starting of line.

The override function becomes valid when all the conditions listed below are satisfied:

- The incandescent lamp with 3.6 to 30W shall be connected to either muting lamp output 1 or 2, or to both of the inputs.
- The signal shall be input to either muting sensor 1 or 2, or to both of the inputs.
- The override input terminal O1 and O2 shall be short-circuited and the test input terminal T1 / T2 shall be opened within 1 sec. (3 sec. continuously). The override function turns ON either short-circuiting the override input terminal, or opening the test input terminal, whichever operates first.

If one of the three conditions above becomes invalid or timing exceeds 60 sec., the override function becomes invalid.

● **Auxiliary output 1**

Muting operation state is outputted.
When the muting function is invalid: ON
When the muting function is valid: OFF

● **Auxiliary output 2**

Override operation state is outputted.
When the override function is invalid: ON
When the override function is valid: OFF

● **Auxiliary output 3**

Blown lamp is outputted.
(When the two lamps are connected, the signal is outputted if one of them blows.)
When the muting lamp is normal: ON
When the muting lamp is in error: OFF
(Always OFF when only one lamp is used.)

● **Auxiliary output 4**

The auxiliary output of the light curtain.
When the light curtain is in the light blocked status: ON
When the light curtain is in the light received status: OFF

● **Interference prevention function**

Max. three sets (total 192 beam channels) of the light curtain can be connected in parallel by using the interference prevention terminals (IE+, IE-, IR+ and IR-).

1. **Connection between SF-C14EXs.**



2. **Connection between a unit of light curtain and SF-C14EX**
<When connecting to emitter of the light curtain>

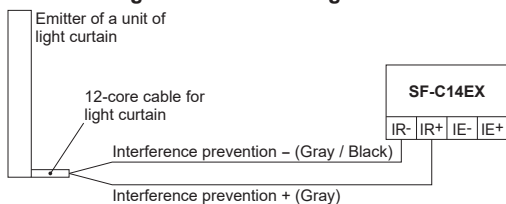

<When connecting to receiver of the light curtain>

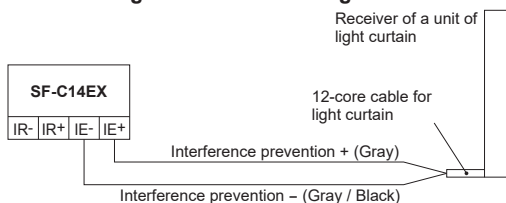

- Notes: 1) The interference prevention wire for connection between SF-C14EXs should be 0.5m or less. If the length is 0.5m or more, use ø0.2mm² or more shielded twisted pair cable.
2) The interference prevention wire for connection with a unit of light curtain should be 12-core cable.
3) Refer to the instruction manual enclosed with the light curtain for details of the connection with a unit of light curtain.

12 FUNCTIONS USING HANDY CONTROLLER SFB-HC (OPTIONAL)

- The following settings can be done with the handy-controller SFB-HC (Ver. 2 or later) (optional).
Note that the SFB-HC (Ver. 1) cannot be used for those settings. (Refer to the name plate affixed on the product.)
- Refer to the instruction manual enclosed with the handy controller for details of the function settings.

⚠ WARNING

Among the functions, the contents related to the safety distance such as the size of the minimum sensing object and response time are varied depending on the setting condition. When setting each function, recalculate the safety distance, and make enough space larger than the calculated safety distance. Failure to do so might cause the accident that the machine cannot stop quickly before reaching the dangerous area of the machine, resulting in death or serious injury.

- The information of the connected SF4B / SF4B<V2> series is stored when the muting setting changing function / the fixed blanking function / the floating blanking function is set (the number of sensors / beam channels). If the different configured SF4B / SF4B<V2> series from that stored at the last setting is connected, "E" is displayed in the digital display (red).
- When the muting function and the fixed blanking function / the floating blanking function are set, the fixed blanking function / the floating blanking function are prioritized.

● **Fixed blanking function**

This function enables to protect the control output (OSSD 1 / 2) from turning into OFF even though the specific beam channel is blocked. The factory setting is set to be invalid for the fixed blanking function.

● **Floating blanking function**

This function enables to protect the control output (OSSD 1 / 2) from turning into OFF even though the number of the blocked beam channels are lower than that of the setting beam channels. One, two or three beam channels are settable as the blocking beam channels. The factory setting is set to be invalid for the floating blanking function.

Both fixed blanking function and floating blanking function are settable simultaneously.

● **Emission intensity control function**

Emission intensity is the set value of the connected SF4B / SF4B<V2> series. The factory setting of SF4B / SF4B<V2> series is normal mode.

● **Auxiliary output 4 switching function (non-safety output)**

The following outputs are switchable as the auxiliary output 4 switching function.

- Negative logic of the control output (OSSD 1) (factory setting)
- Positive logic of the control output (OSSD 1)
- For unstable incident light: OFF (Note 1)
- For unstable incident light: ON (Note 1)
- For emission: ON (Note 2)
- For emission: OFF (Note 2)
- For light reception: ON, For light blocked: OFF (Note 3)
- For light reception: OFF, For light blocked: ON (Note 3)

- Notes: 1) The output cannot be used while the fix blanking function, floating blanking function or the muting function is activated.
2) Emission halt cannot be done by using the emission halt input wire of the SF4B / SF4B<V2> series.
3) This product outputs the light received / blocked state under activating the auxiliary output switching function using the handy controller irrespective of activating other functions: fixed blanking function, floating blanking function and muting function.

<e.g.>

In case of activating the fixed blanking function, the control output (OSSD 1 / 2) becomes ON with the shielded object existed in the setting range and other ranges are in light received state. If the auxiliary output 4 switching function activates in No. 4 output, this product becomes OFF because the SF4B / SF4B<V2> series itself detects the object.

● **Muting setting changing function**

- The setting of the muting function is changeable.
 1. Output order of the muting sensor 1 and 2 can be specified so that the muting function will be valid. When the output order of the muting sensor 1 / 2 is designated, the time-lag for inputting requires 30ms or more. The muting function will be valid either the muting sensor 1 or 2 comes first to output at the time of factory setting.
 2. Select either to validate or invalidate the muting function per beam channel. (Note 1)
The muting function is valid in all beam channels at the time of factory setting.
 3. Select either to validate or invalidate the muting lamp diagnosis function. When the setting is invalid, the auxiliary output 3 (Blown lamp output) (Terminal: AUX3) stays ON state.
The factory setting is valid for this.

- Notes: 1) When the light is blocked on the beam channel set as the muting function invalid while the muting function is active, the control output (OSSD 1 / 2) is turned OFF and the muting function becomes invalid.
2) If the muting lamp diagnosis function is set to be invalid, the muting function is maintained even if a lamp blows or a lamp is not connected.

● **Protective function**

Unless the password is inputted, any change in setting of the SF4B / SF4B<V2> series is not allowed. The factory setting is set to be invalid for the protective function.

13 SPECIFICATIONS

Designation	Application expansion unit exclusive for light curtain
Item	Model No. SF-C14EX
Connectable input device	SF4B / SF4B<V2> series and SF4B-□-01 / SF4B-□-01<V2>
Applicable standard	EN 55011, EN IEC 63000, EN 61496-1 (Type 4) EN ISO 13849-1: 2015 (Category 4, PL _e), IEC 61496-1 (Type 4) ISO 13849-1: 2015 (Category 4, PL _e), JIS B 9704-1 (Type 4) JIS B 9705-1 (Category 4), ANSI/UL 61496-1 (Type 4), UL 1998 (Class 2)
Supply voltage	24V DC±10% Ripple P-P 10% or less
Current consumption	0.2A or less (Excluding light curtain and other external connecting device)
Safety output (Note 1) (Safety output 1) (Safety output 2) (Safety output 3)	PNP / NPN open-collector transistor × 3 <When PNP output is selected> <ul style="list-style-type: none"> Maximum source current: 200mA Applied voltage: same as supply voltage (between the safety output and +V) Residual voltage: 2V or less (at 200mA source current) Leakage current: 2mA or less (Including power supply OFF condition) Maximum load capacity: 0.22μF (No load to maximum output current) Load wiring resistance: 3Ω or less <When NPN output is selected> <ul style="list-style-type: none"> Maximum sink current: 200mA Applied voltage: same as supply voltage (between the safety output and 0V) Residual voltage: 2V or less (at 200mA sink current) Leakage current: 2mA or less (Including power supply OFF condition) Maximum load capacity: 0.22μF (No load to maximum output current) Load wiring resistance: 3Ω or less
Operation mode (Output operation)	<Safety output 1> When light curtain is in light received status: ON When light curtain is in light blocked status: OFF (Note 2) <Safety output 2> When light curtain is in light received status or the muting function is valid: ON When light curtain is in light blocked status and the muting function is invalid: OFF (Note 2) <Safety output 3> When the emergency stop is invalid: ON When the emergency stop is valid: OFF
Protection circuit (Short-circuit protection)	Incorporated
Response time	OFF response: 14ms or less (safety output 1 / 2 includes response time of light curtain) ON response: 90ms or less (auto-reset) / 140ms or less (manual reset) (Note 3)
Auxiliary output Auxiliary output 1 Auxiliary output 2 Auxiliary output 3 Auxiliary output 4 (Note 4)	PNP / NPN open-collector transistor × 3 <When PNP output is selected> <ul style="list-style-type: none"> Maximum source current: 60mA Applied voltage: same as supply voltage (between the auxiliary output and +V) Residual voltage: 2V or less (at 60mA source current) <When NPN output is selected> <ul style="list-style-type: none"> Maximum sink current: 60mA Applied voltage: same as supply voltage (between the auxiliary output and 0V) Residual voltage: 2V or less (at 60mA sink current)
Operation mode (Output operation)	<Auxiliary output 1> When the muting function is invalid: ON When the muting function is valid: OFF <Auxiliary output 2> When the override function is invalid: ON When the override function is valid: OFF <Auxiliary output 3> When the muting lamp is normal: ON When the muting lamp is in error: OFF <Auxiliary output 4> When light curtain is in light blocked status: ON When light curtain is in light received status: OFF (Note 4)
Protection circuit (Short-circuit protection)	Incorporated
Muting lamp output	Applicable muting indicator: 24V DC, 3.6 to 30W (per unit)
Protection circuit (Short-circuit protection)	Incorporated
Protection	Enclosure: IP40, Terminal: IP20 (This product must be installed into a control box having IP54 construction.)
Pollution degree	2
Ambient temperature	-10 to +55°C (No dew condensation or icing allowed) Storage: -25 to +70°C
Ambient humidity	30 to 85% RH, Storage: 30 to 95% RH
Overvoltage category	III
PFHd (Note 5)	1.64 × 10 ⁻¹⁰
MTTFd (Note 6)	More than 100 years
Mission time	20 years
Connection terminal	Detachable spring gauge terminal
Cable extension	Extension up to 50m is possible (Note 7)
Material	Enclosure: ABS
Weight	Approx. 250g

Notes: 1) Timing chart of the safety output is diagram below.

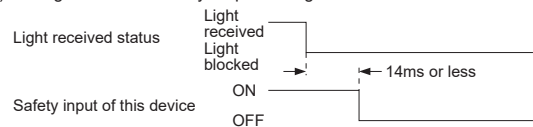

- Both safety output 1 and 2 are OFF when the emergency stop is valid regardless of whether the light curtain is in the light received or light blocked status.
- The auto-reset cannot be used with safety output 3.
- The auxiliary output incorporated in the light curtain is outputted.
- Probability of dangerous failure per hour.
- Mean time to dangerous failure.
- In case of extending the cable, be sure to use the **SFB-CCJ10E** (for the emitter: cable length 10m) / **SFB-CCJ10D** (for the receiver: cable length 10m). The cable can be extended within 30m (for emitter / receiver) when two products are connected in series connection, within 20m (for emitter / receiver) when three products are connected in series connection. However, the cable cannot be extended for parallel connection.

14 TROUBLESHOOTING

Symptom	Cause	Remedy
" 1 " lights up on the digital indicator (red)	Setting data error of the product	<ul style="list-style-type: none"> • Check the noise state. • In case the handy controller SFB-HC (optional) is applied, reset the function. • If the error is not cleared, contact our office.
" 2 " blinks on the digital indicator (red)	Emergency stop input error	<ul style="list-style-type: none"> • Wire the emergency stop input / output wire correctly.
" 3 " blinks on the digital indicator (red)	The total number of sensors / total number of beam channels error	<ul style="list-style-type: none"> • Check the total number of sensors / total number of beam channels.
" 4 " blinks on the digital indicator (red)	Reset input error	<ul style="list-style-type: none"> • Wire the reset input / output wire correctly.
" 5 " blinks on the digital indicator (red)	Safety output error (Safety output circuit error)	<ul style="list-style-type: none"> • Wire the safety output wire correctly.
" 6 " blinks on the digital indicator (red)	PNP / NPN setting error	<ul style="list-style-type: none"> • Change the setting after turning the power OFF.
" 8 " blinks on the digital indicator (red)	Input voltage monitor error	<ul style="list-style-type: none"> • Check the supply voltage and the voltage capacity.
" 9 " blinks on the digital indicator (red)	Safety output error (Safety output short-circuited)	<ul style="list-style-type: none"> • Wire the safety output wire correctly.
" b " lights up on the digital indicator (red)	The blanking function is valid.	<ul style="list-style-type: none"> • The blanking function is valid. (Normal operation)
" c " lights up on the digital indicator (red)	Light curtain communication error	<ul style="list-style-type: none"> • Check if the light curtain is connected correctly. • Check the operation of the connected light curtain.
" d " blinks on the digital indicator (red)	Safety output circuit error	<ul style="list-style-type: none"> • Check the noise state.
" e " blinks on the digital indicator (red)	Effect by noise, power, etc. or internal circuit failure	<ul style="list-style-type: none"> • Check the noise state.
" F " blinks on the digital indicator (red)	Internal error of the product	<ul style="list-style-type: none"> • Check the noise state. • Check the wiring, supply voltage and voltage capacity. • If the product does not work correctly, contact our office.
The test input indicator (yellow) lights up	The product is in test state.	<ul style="list-style-type: none"> • Wire the test input wire correctly.
The test input indicator (yellow) blinks	The handy controller SFB-HC has been connected.	<ul style="list-style-type: none"> • Remove the handy controller SFB-HC.
Only the power indicator (green) and the auxiliary output 1, 2 and 3 indicators (orange) light up. (All of the safety outputs 1, 2 and 3 are OFF.)	The product is in emergency stop state.	<ul style="list-style-type: none"> • Wire the emergency stop input / output terminals between S11 and S12, and S21 and S22 correctly. • Check if the emergency stop switch has been "pressed."
The interlock indicator (yellow) lights up.	Reset cannot be canceled.	<ul style="list-style-type: none"> • Wire the reset input / output wire correctly. • Change the relay having appropriate response time. • Replace the relay.

15 MAINTENANCE

- Be sure to do maintenance before use and 6 month periodic maintenance. Refer included instruction manual of light curtain for the inspection items.
- In case replacing this device to new this device, be sure special technician to exchange it. And do daily maintenance and periodic maintenance.

16 DIMENSIONS (Unit: mm)

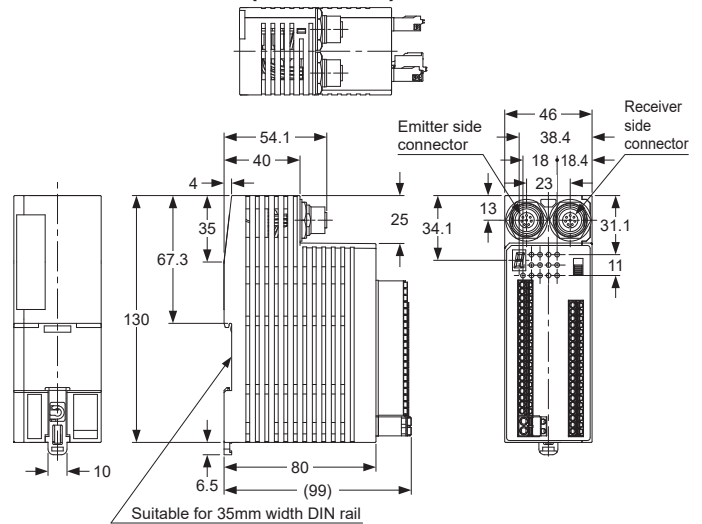

17 INTENDED PRODUCTS FOR CE MARKING

- The model listed under "18 SPECIFICATIONS" comes with CE Marking.
- As for all other models, please contact our office.

18 CE MARKING DECLARATION OF CONFORMITY

Itemized Essentials of EU Declaration of Conformity

Manufacturer's Name: Panasonic Industrial Devices SUNX Co., Ltd.
Manufacturer's Address: 2431-1, Ushiyama-cho, Kasugai, Aichi 486-0901, Japan

EU Representative's Name: Panasonic Marketing Europe GmbH Panasonic Testing Center
EU Representative's Address: Winsbergring 15, 22525 Hamburg, Germany

Product: Exclusive Control Unit for Light Curtain

Model Name: SF-C10 Series

Trade Name: Panasonic

Application of Council Directive:

- 2006/42/EC Machinery Directive
- 2014/30/EU EMC Directive
- 2011/65/EU RoHS Directive

Applicable Standard(s):

- EN ISO 13849-1: 2015
- EN 55011
- EN 61496-1
- EN IEC 63000

Type Examination: Certified by TÜV SÜD Product Service GmbH
 Ridlerstrasse 65 80339 München Germany

Panasonic Corporation

Panasonic Industrial Devices SUNX Co., Ltd.

<https://panasonic.net/id/pidsx/global>

Please visit our website for inquiries and about our sales network.

PRINTED IN JAPAN

© Panasonic Industrial Devices SUNX Co., Ltd. 2021