

**Light Curtain / Type 2
SF2C Series**

ME-SF2C No.0095-45V

Thank you very much for purchasing Panasonic products. Read this Instruction Manual carefully and thoroughly for the correct and optimum use of this product. Kindly keep this manual in a convenient place for quick reference.

- This is an abridged instruction manual simply explains mounting, wiring and etc. Kindly refer "our web site (<https://industry.panasonic.com/>)" when you need more detail of contents.
- Instruction Manuals in the following languages are published on our Web site. Japanese, English, Chinese, Korean, German, French, Spanish, Italian, Brazilian Portuguese
- Die deutsche Betriebsanleitung ist auf unserer Website veröffentlicht.
- Le manuel d'instructions français est publié sur notre site web.
- El Manual de Instrucciones en español se encuentra publicado en nuestro sitio web.
- Il manuale di istruzioni italiano è pubblicato sul nostro sito web.
- O Manual de Instruções em Português Brasileiro está publicado em nosso Web site.

1 SAFETY PRECAUTIONS

- Use this device as per its specifications. Do not modify this device since its functions and capabilities may not be maintained and it may malfunction.
- This device has been developed / produced for industrial use only.
- This device is suitable for indoor use only.
- Use of this device under the following conditions or environments is not presupposed. Please consult us if there is no other choice but to use this device in such an environment.
 - 1) Operating this device under conditions or environments not described in this manual.
 - 2) Using this device in the following fields: nuclear power control, railroad, aircraft, auto mobiles, combustion facilities, medical systems, aerospace development, etc.
- When this device is to be used for enforcing protection of a person from any danger occurring around an operating machine, the user should satisfy the regulations established by national or regional security committees (Occupational Safety and Health Administration: OSHA, the European Standardization Committee, etc.). Contact the relative organization(s) for details.
- In case of installing this device to a particular machine, follow the safety regulations in regard to appropriate usage, mounting (installation), operation and maintenance. The users including the installation operator are responsible for the introduction of this device.
- Note that this device may be damaged if it is subject to a strong shock (if it is dropped onto the floor, for example).
- Use this device by installing suitable protection equipment as a countermeasure for failure, damage, or malfunction of this device.
- Before using this device, check whether the device performs properly with the functions and capabilities as per the design specifications.
- In case of disposal, dispose this device as an industrial waste.

WARNING

- ♦ **Machine designer, installer, employer and operator**
 - The machine designer, installer, employer and operator are solely responsible to ensure that all applicable legal requirements relating to the installation and the use in any application are satisfied and all instructions for installation and maintenance contained in the instruction manual are followed.
 - Whether this device functions as intended to and systems including this device comply with safety regulations depends on the appropriateness of the application, installation, maintenance and operation. The machine designer, installer, employer and operator are solely responsible for these items.
- ♦ **Engineer**
 - The engineer would be a person who is appropriately educated, has widespread knowledge and experience, and can solve various problems which may arise during work, such as a machine designer, or a person in charge of installation or operation etc.
- ♦ **Operator**
 - The operator should read this instruction manual thoroughly, understand its contents, and perform operations following the procedures described in this manual for the correct operation of this device.
 - In case this device does not perform properly, the operator should report this to the person in charge and stop the machine operation immediately. The machine must not be operated until correct performance of this device has been confirmed.
- ♦ **Environment**
 - Do not use a mobile phone or a radio phone near this device.
 - If there exists a reflective surface in the place where this device is to be installed, make sure to install this device so that reflected light from the reflective surface does not enter into the receiver, or take countermeasures such as painting, masking, roughening, or changing the material of the reflective surface, etc. Failure to do so may cause the device not to detect, resulting in death or serious injury.
 - Do not install this device in the following environments.
 - 1) Areas exposed to intense interference (extraneous) light such as high-frequency fluorescent lamp (inverter type), rapid starter fluorescent lamp, stroboscopic lights or direct sunlight.
 - 2) Areas with high humidity where condensation is likely to occur
 - 3) Areas exposed to corrosive or explosive gases
 - 4) Areas exposed to vibration or shock of levels higher than that specified
 - 5) Areas exposed to contact with water
 - 6) Areas exposed to too much steam or dust
- ♦ **Installation**
 - Always keep the correctly calculated safety distance between this device and the dangerous parts of the machine.
 - Install extra protection structure around the machine so that the operator must pass through the sensing area of this device to reach the dangerous parts of the machine.
 - Install this device such that some part of the operator's body always remains in the sensing area when operator is done with the dangerous parts of the machine.
 - Do not install this device at a location where it can be affected by wall reflection.
 - When installing multiple sets of this device, connect the sets and, if necessary, install some barriers such that mutual interference does not occur. For details, refer to "4 DEVICE PLACEMENT."
 - Do not use this device in a reflective configuration.
 - The corresponding emitter and receiver must have the same serial No. and be correctly oriented.

♦ **Machine in which this device is installed**

- When this device is used in the "PSDI Mode," an appropriate control circuit must be configured between this device and the machinery. For details, be sure to refer to the standards or regulations applicable in each region or country.
- In Japan and China, Korea, do not use this device as safety equipment for a press machine.
- Do not install this device with a machine whose operation cannot be stopped immediately in the middle of an operation cycle by an emergency stop equipment.
- This device starts the performance after 2 seconds from the power ON. Have the control system started to function with this timing.

♦ **Wiring**

- Be sure to carry out the wiring in the power supply OFF condition.
- All electrical wiring should conform to the regional electrical regulations and laws. The wiring should be done by engineer(s) having the special electrical knowledge.
- Do not run the wires together with high-voltage lines or power lines or put them in the same raceway. This can cause malfunction due to induction.
- In case of extending the cable of the emitter or the receiver, each can be extended up to 50m by using the exclusive cable. Extending the cable longer than 50m may cause malfunction, which can result in death or serious injury.
- Use both control output (OSSD) and lockout output (SSD).
- In order that the output is not turned ON due to earth fault of control output (OSSD 1 / 2), be sure to ground to 0V side (PNP output) / +24V side (NPN output).

♦ **Maintenance**

- When replacement parts are required, always use only genuine supplied replacement parts. If substitute parts from another manufacturer are used, the device may not come to detect, result in death or serious injury.
- The periodical inspection of this device must be performed by an engineer having the special knowledge.
- After maintenance or adjustment, and before starting operation, test this device following the procedure specified in "5 MAINTENANCE."
- Clean this device with a clean cloth. Do not use any volatile chemicals.

♦ **Others**

- Never modify this device. Modification may cause the device not to detect, resulting in death or serious injury.
- Do not use this device to detect objects flying over the sensing area.
- Do not use this device to detect transparent objects, translucent objects or objects smaller than the specified minimum sensing objects.

2 CONFIRMATION OF PACKED CONTENTS

- Sensor: Emitter, Receiver 1 pc. each
- Test Rod SF4C-TR25 (ø25 × 220mm) 1 pc.
- Quick Instruction Manual (Japanese, English, Chinese, Korean) 1 pc. each language
- General Information for Safety, Compliance, and Instructions 1 pc.

3 PART DESCRIPTION OF INDICATORS

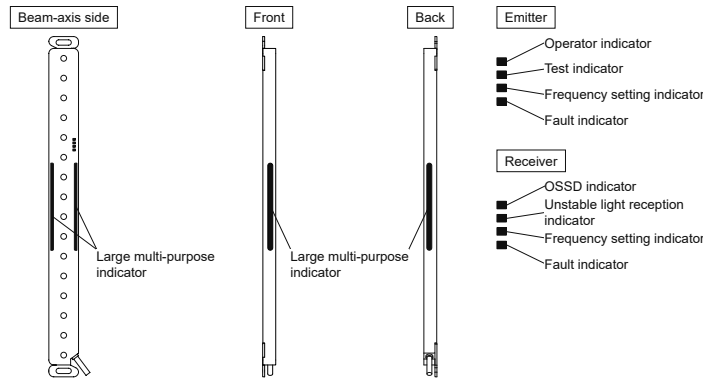

• **Common to emitter and receiver**

Description	Function
Large multi-purpose indicator (Orange)	Lights up when input for the large multi-purpose indicator is valid. Turns OFF when input for the large multi-purpose indicator is invalid.
Frequency setting indicator (Orange)	Turns OFF when Frequency 1 is set. Lights up when Frequency 2 is set.
Fault indicator (Yellow)	Turns OFF during normal operation. Lights up or blinks when fault occurs in the device.

• **Emitter**

Description	Function
Operation indicator (Green)	Lights up when device operation is as follows. Turns OFF when test input is valid.
Test indicator (Red)	Lights up when test input is valid. Turns OFF when test input is invalid.

• **Receiver**

Description	Function
OSSD indicator (Red / Green)	When control output (OSSD) is OFF, lights up in red. When control output (OSSD) is ON, lights up in green.
Unstable light reception indicator (Orange)	Turns OFF when stable light is received (the percentage of light received is more than 150%) [Control output (OSSD) ON] Lights up when unstable light is received (the percentage of light received is between 100% and 150%). [Control output (OSSD) ON] Turns OFF when light is blocked (the percentage of light received is less than 100%) [Control output (OSSD) OFF]

4 DEVICE PLACEMENT

- This is the configuration when two or more sets of emitter and receiver facing each other are placed. It is used for the case that there is a problem in wiring or for system evaluation in case of addition of equipment. It is used for system evaluation in case of addition of equipment.

WARNING

- Refer to the examples of device placement given below and understand them thoroughly before installing the devices. Improper sensor placement could cause device malfunction, which can result in death or serious injury.
- If this device is used in multiple sets, arrange them to avoid mutual interference. If mutual interference occurs, it can result in death or serious injury.

<Example of device placement>

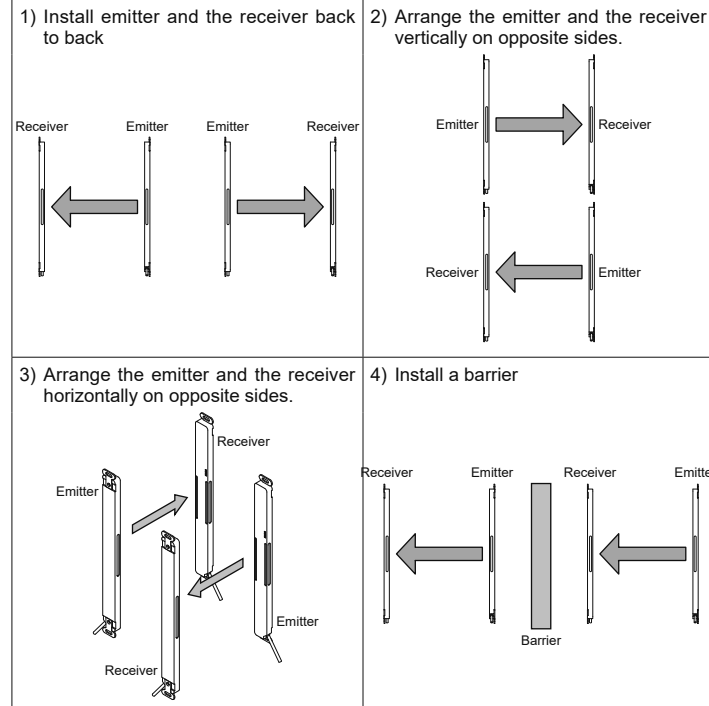

<Reference>

The above figures are just examples of device placement. If there are any questions or problems, please contact our office.

WARNING

Position the emitter and receiver so that their cables are aligned. Failure to do so will cause the system to malfunction.

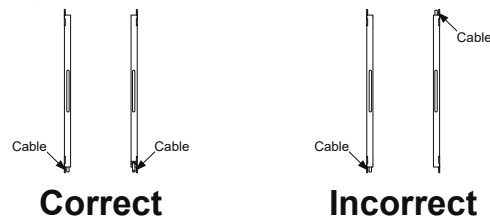

5 MOUNTING

CAUTION

The minimum bending radius of the cable is R5mm. Mount the device considering the cable bending radius.

<Reference>

Mount the emitter and the receiver at the same level and parallel to each other. The effective aperture angle of this device is ±5° or less for a sensing distance of 3m or more.

<In case of using standard mounting bracket (MS-SFC-1) (accessory)>

1. Remove the M3 countersunk head screw [with anti-loosening agent (length 4mm)] which is attached to the back of the device.
2. Decide the direction of the standard mounting bracket.
3. Tighten with the M3 countersunk head screw [with anti-loosening agent (length 4mm)]. The tightening torque should be 0.3 N·m or less.

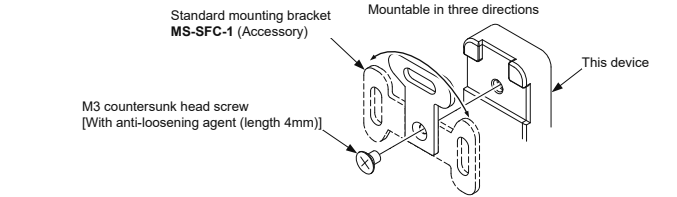

4. Set the standard mounting bracket that is ready for setting to the mounting surface using two hexagon-socket head bolts [M5 (please arrange separately)].

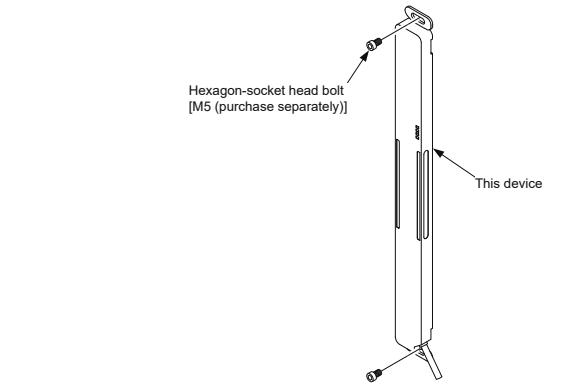

Note: The case of the product is made of resin so the longitudinal dimension is subject to expansion and contraction. When drilling mounting holes, check the drilling locations by positioning the actual product at the installation location.

6 WIRING

WARNING

- Earth the machine or the support where the device is mounted on to frame ground (F.G.). Failure to do so could cause the malfunction of the device by noise, resulting in death or serious injury. Furthermore, the wiring should be done in a metal box connected to the frame ground (F.G.).
- Take countermeasure against the system to be applied for this device so as not to carry out the dangerous performance caused by the earth failure. Failure to do so could cause invalid for the system stop, resulting in death or serious injury.
- In order that the output is not turned ON due to earth fault of control output (OSSD), be sure to ground to 0V side (PNP output) / +V side (NPN output).

CAUTION

Make sure to insulate the ends of the unused lead wires.

<Reference>

Use a safety relay unit or an equivalent control circuit in safety for FSD.

• **Power Supply Unit**

CAUTION

Wire correctly using a power supply unit which conforms to the laws and standards of the region where this device is to be used. If the power supply unit is non-conforming or the wiring is improper, it can cause damage or malfunction of this device.

<Reference>
 A specialist who has the required electrical knowledge should perform the wiring. The power supply unit must satisfy the conditions given below.
 1) Power supply unit authorized in the region where this device is to be used.
 2) The power supply unit must be a SELV (safety extra low voltage) / PELV (protected extra low voltage) unit that conforms to the EMC Directive and Low-voltage Directive. (When CE marking is required.)
 3) The power supply unit must be a SELV (safety extra low voltage) / PELV (protected extra low voltage) unit that conforms to the EMC Regulations and Electrical Equipment (Safety) Regulations. (When UKCA marking is required.)
 4) The frame ground (F.G.) terminal must be connected to ground when using a commercially available switching regulator.
 5) Power supply unit with an output holding time of 20ms or more.
 6) In case a surge is generated, take countermeasures such as connecting a surge absorber to the origin of the surge.
 7) Power supply unit corresponding to CLASS 2 (only for requiring cTUVus Mark conformation).

• I/O Circuit Diagrams

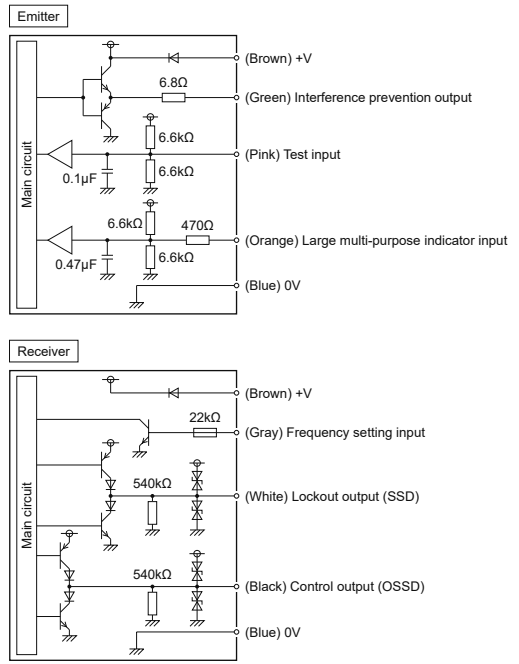

• Basic Wiring

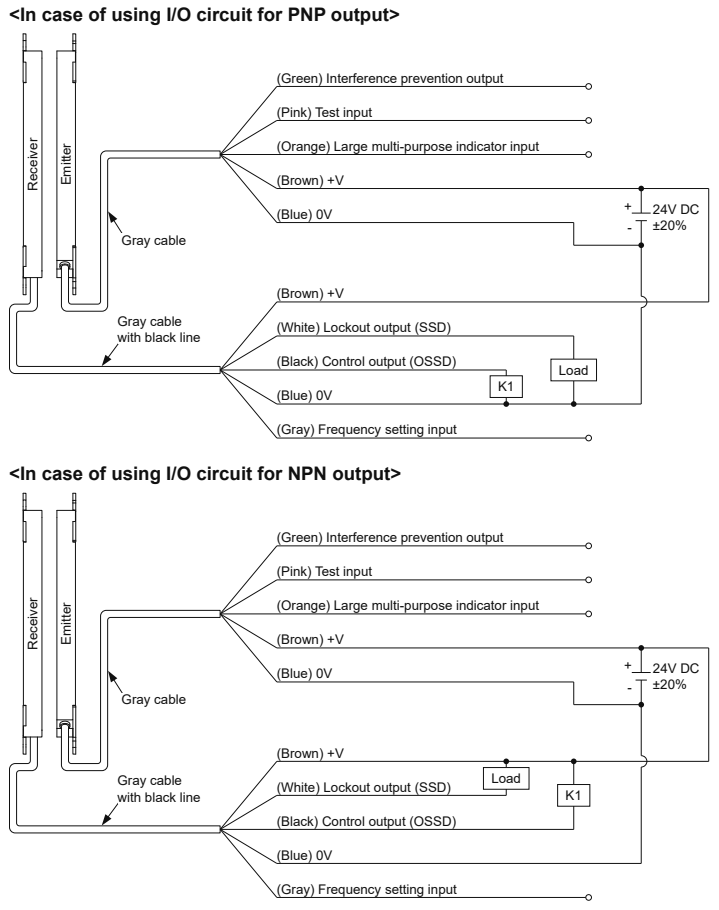

<Reference>
 K1: External device (Forced guided relay or magnetic contactor)

• Wiring for Test Input Function / Large Multi-purpose Indicator Function / Interference Prevention Function

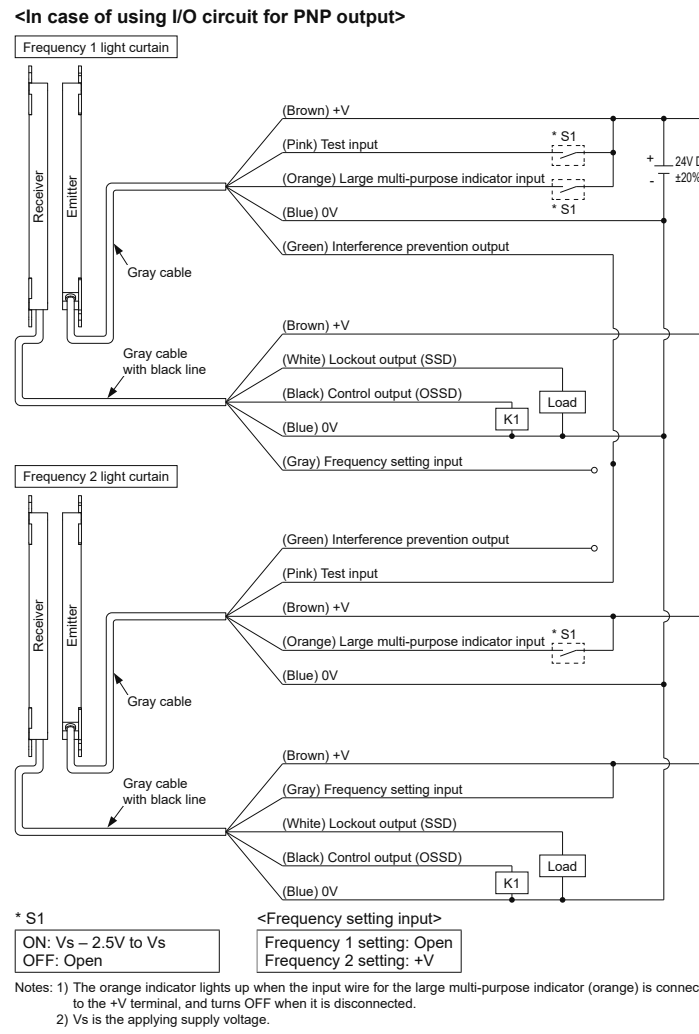

<Reference>
 K1: External device (Forced guided relay or magnetic contactor)

7 OPERATION OF INDICATORS

- Normal Operation**
■: Lights up in red, ■: Lights up in green, : Turns OFF

Device status	Indicators		Control output (OSSD)	Lockout output (SSD)
	Emitter	Receiver		
Before power is ON	 POWER TEST FREQ FAULT	 OSSD STB FREQ FAULT	OFF	OFF
After power is ON Light received status (all beams received)	■ POWER TEST FREQ FAULT	■ OSSD STB FREQ FAULT	ON	ON
After power is ON Light blocked status One or more beams blocked	■ POWER TEST FREQ FAULT	■ OSSD STB FREQ FAULT	OFF	ON

• When an error occurs

- : Blinks in yellow, : Blinks in orange, ■: Lights up in red, ■: Lights up in green, : Turns OFF

Setting procedure and check items	Indicators (Note)		Control output (OSSD)	Lockout output (SSD)
	Emitter	Receiver		
Normal state	■ POWER TEST FREQ FAULT	■ OSSD STB FREQ FAULT	ON	ON
Error state	Emitter abnormal	 POWER TEST FREQ FAULT	OFF	OFF
	Receiver abnormal	■ POWER TEST FREQ FAULT	OFF	OFF

8 FUNCTION

- Refer "our web site (<https://industry.panasonic.com/>)" for details of functions of this product.

9 MAINTENANCE

<Reference>
 When any errors are found, refer to "our web site (<https://industry.panasonic.com/>)" and report the symptoms to the maintenance in charge. If the rectification method is not clear, please contact our office.
 Please make a copy of this checklist, check each inspection item in the respective square, and file the list for record.

• Daily Inspection

⚠ WARNING

Be sure to inspect the following items prior to operation and confirm that there is no error. Operating this device without inspection or in an error condition can result in death or serious injury.

Check column	Inspection item
<input type="checkbox"/>	Dangerous parts of the machine cannot be reached without passing through the sensing area of this device.
<input type="checkbox"/>	Some part of operator's body remains in the sensing area when operation is done with dangerous parts of the machine.
<input type="checkbox"/>	The calculated safety distance has been maintained or exceeded during installation.
<input type="checkbox"/>	There is no damage to the safety guard or protective structure.
<input type="checkbox"/>	There is no defect, fold, or damage in the wiring.
<input type="checkbox"/>	The corresponding connectors have been connected securely.
<input type="checkbox"/>	No dirt or scratches exist on the light emitting surface.
<input type="checkbox"/>	The test rod is not deformed or defective.
<input type="checkbox"/>	The operation indicator (green) of the emitter and the OSSD indicator (green) of the receiver light up when no object is present in the sensing area. The control output (OSSD) shall be ON. At this time, the effect of external noise can be inspected. In case external noise affects the operation, remove its cause and reinspect.
<input type="checkbox"/>	Move the test rod (ø25mm) up and down 1,600 mm/sec. or less at three positions, just in front of the emitter, between the emitter and receiver and just in front of the receiver. The OSSD indicator (red) of the receiver and the operation indicator (red) of the emitter continue to light up as long as the test rod is present in the sensing area.
<input type="checkbox"/>	With the machine in the operating condition, the dangerous parts operate normally when no object is present in the sensing area.
<input type="checkbox"/>	With the machine in the operating condition, the dangerous parts stop immediately when the test rod (ø25mm) is inserted into the sensing area at any of the three positions, directly in front of the emitter, midway between the emitter and the receiver, and directly in front of the receiver.
<input type="checkbox"/>	The dangerous parts remain stopped as long as the test rod is present in the sensing area.
<input type="checkbox"/>	The dangerous parts stop immediately when the power supply of this device is turned OFF.
<input type="checkbox"/>	The control output (OSSD) must turn OFF when the test input wire (pink) is open (PNP output type: connected to +V, NPN output type: connected to 0V). At this time, the effect of external noise can be inspected. In case external noise affects the operation, remove its cause and reinspect.

• Periodic Inspection (Every Six Months)

⚠ WARNING

Be sure to inspect the following items every six months and confirm that there is no error. Operating this device without inspection or in an error condition can result in death or serious injury.

Check column	Inspection item
<input type="checkbox"/>	The structure of the machine does not obstruct any safety mechanism for stopping operation.
<input type="checkbox"/>	No modification has been made in the machine controls which obstructs the safety mechanisms.
<input type="checkbox"/>	The output of this device is correctly detected.
<input type="checkbox"/>	The wiring from this device is correct.
<input type="checkbox"/>	The overall response time of the complete machine is equal or less than the calculated value.
<input type="checkbox"/>	The actual number of operation cycle (time) of the limited lifetime parts (relay, etc.) is less than their rated operation cycles (time).
<input type="checkbox"/>	No screws or connectors of this device are loose.
<input type="checkbox"/>	No extraneous light source or reflective object has been added near this device.

• Inspection after Maintenance

- When any parts of this device are replaced.
- When some abnormality is felt during operation.
- When beam-axis alignment of the emitter and receiver is done.
- When the device installation place or environment is changed.
- When the wiring method or wiring layout is changed.
- When FSD (Final Switching Device) parts are replaced.
- When FSD (Final Switching Device) setting is changed.

10 SPECIFICATIONS

Type	20mm pitch type
Model No.	SF2C-H _n
Number of beam channels	8 / 12 / 16 / 20 / 24 / 28 / 32
Protective height	160 (8 channels) to 640 (32 channels) mm
Sensing range	0.1 to 3m
Minimum sensing object	ø25mm opaque object
Supply voltage	24V DC ±20%
Control output (OSSD)	Maximum source (PNP) / sink (NPN) current: 200mA, Residual voltage: 2.5V or less Leakage current: 200μA or less, Maximum load capacity: 2.2μF, Load wiring resistance: 3Ω or less
Response time	When OFF: 20ms or less, When ON: 80 to 100ms
Lockout output (SSD)	Maximum source (PNP) / sink (NPN) current: 60mA, Residual voltage: 2.5V or less Leakage current: 200μA or less, Maximum load capacity: 2.2μF, Load wiring resistance: 3Ω or less
Ambient temperature	-10 to +55°C, Storage: -25 to +60°C
Ambient humidity	30 to 85%RH, Storage: 30 to 85%RH

11 CE MARKING DECLARATION OF CONFORMITY

Itemized Essentials of EU Declaration of Conformity

Manufacturer's Name: Panasonic Industry Co., Ltd.
Manufacturer's Address: 1006, Oaza Kadoma, Kadoma-shi, Osaka 571-8506, Japan
Product Name: Active Opto-electronic Protective Device (Light Curtain)
Model Number: SF2C Series
Trade Name: Panasonic

Application of Council Directives:
 - 2006/42/EC Machinery
 - 2014/30/EU EMC
 - 2011/65/EU RoHS

Applicable Standards:
 - EN ISO 13849-1: 2015 - IEC 61496-1
 - EN 55011 - IEC 61496-2
 - EN 61000-6-2 - IEC 61508-1
 - EN IEC 63000 - IEC 61508-2
 - IEC 61508-3

Authorised Representative:
 Panasonic Marketing Europe GmbH, Panasonic Testing Centre
 Winsbergring 15, 22525 Hamburg, Germany

12 UKCA MARKING DECLARATION OF CONFORMITY

Itemized Essentials of UK Declaration of Conformity

Manufacturer's Name: Panasonic Industry Co., Ltd.
Manufacturer's Address: 1006, Oaza Kadoma, Kadoma-shi, Osaka 571-8506, Japan
Product Name: Active Opto-electronic Protective Device (Light Curtain)
Trade Name: Panasonic
Model Number: SF2C Series

Statutory Instruments:
 - 2008/1597 Machinery
 - 2016/1091 EMC
 - 2012/3032 RoHS

Designated Standards:
 - EN ISO 13849-1: 2015 - IEC 61496-1
 - EN 55011 - IEC 61496-2
 - EN 61000-6-2 - IEC 61508-1
 - EN IEC 63000 - IEC 61508-2
 - IEC 61508-3

Panasonic UK, a branch of Panasonic Marketing Europe GmbH
 Maxis 2, Western Road, Bracknell, Berkshire, RG12 1RT

Panasonic Industry Co., Ltd.

1006, Oaza Kadoma, Kadoma-shi, Osaka 571-8506, Japan
<https://industry.panasonic.com/>

Please visit our website for inquiries and about our sales network.

Panasonic Industry Co., Ltd. 2024

April, 2024

PRINTED IN JAPAN