

Light Curtain / Type 2

## SF2C Series

# Instruction Manual

---

(MEMO)

Thank you for purchasing Panasonic Industry's Ultralim Light Curtain, **SF2C** series.  
Please read this instruction manual carefully and thoroughly for the correct and optimum use of this device.  
Kindly keep this manual in a convenient place for quick reference.

This device is a light curtain for protecting a person from dangerous parts of a machine which can cause injury or accident.

This manual is for the following personnel:

- who have undergone suitable training,
- who have knowledge of the light curtains as well as the safety systems and the standards,
- who are responsible for the introduction of this device,
- who design the system using this device,
- who install and connect this device,
- who manage and operate a plant using this device.

#### Notes

- 1) All the contents of this instruction manual are the copyright of the publishers, and may not be reproduced (even extracts) in any form by any electronic or mechanical means (including photocopying, recording, or information storage and retrieval) without permission in writing from the publisher.
- 2) The contents of this instruction manual may be changed without prior notice for further improvement of the device.
- 3) Though we have carefully drawn up the contents of this instruction manual, if there are any aspects that are not clear, or any error that you may notice, please contact our local Panasonic Industry office of the nearest distributor.
- 4) English and Japanese are original instructions.

# Contents

Chapter 1 Introduction .....	5
1-1 Attention Marks .....	5
1-2 Safety Precautions .....	5
1-3 Regulations And Standards .....	8
1-4 Confirmation of Packed Contents .....	8
Chapter 2 Before Using This Device .....	9
2-1 Features .....	9
2-2 Part Description .....	9
2-3 Protection Area .....	11
2-3-1 Sensing Area .....	11
2-3-2 Safety Distance .....	12
2-3-3 Influence of Reflective Surfaces .....	15
2-3-4 Device Placement .....	16
2-4 Mounting .....	17
2-4-1 Mounting of the Mounting Bracket .....	17
2-5 Wiring .....	23
2-5-1 Power Supply Unit .....	23
2-5-2 I/O Circuit Diagrams .....	24
2-5-3 Basic Wiring .....	26
2-5-4 Wiring for Test Input Function / Large Multi-purpose Indicator Function / Interference Prevention Function .....	27
2-6 Adjustment .....	29
2-6-1 Beam-axis alignment .....	29
2-6-2 Operation Test .....	30
2-6-3 Operation .....	31
Chapter 3 Functions .....	33
3-1 Self-diagnosis Function .....	33
3-2 Test Input Function .....	33
3-3 Lockout Function .....	34
3-3-1 Lockout Output (SSD) .....	34
3-3-2 Lockout Release Function .....	34
3-4 Interference Prevention Function .....	34
3-5 Large Multi-purpose Indicator Function .....	35
Chapter 4 Maintenance .....	36
4-1 Daily Inspection .....	36
4-2 Periodic Inspection (Every Six Months) .....	37
4-3 Inspection after Maintenance .....	37
Chapter 5 Troubleshooting .....	38
5-1 Troubleshooting of Emitter .....	38
5-2 Troubleshooting of Receiver .....	39
Chapter 6 Specifications / Dimensions .....	40
6-1 Specifications .....	40
6-2 Options .....	42
6-3 Dimension .....	43
6-3-1 In Case Mounting on the Center with Standard Mounting Brackets .....	43
6-3-2 In Case Mounting with Standard Mounting Brackets without Dead Space .....	44
6-3-3 In Case Mounting with Multifunctional Mounting Bracket .....	45
6-3-4 In Case Mounting as Dead Space Mounting With Multifunctional Mounting bracket .....	46
6-3-5 In Case Mounting with Protective Metal Case .....	47
6-3-6 Mounting Bracket .....	48

Chapter 7 Others .....	51
7-1 Glossary .....	51
7-2 CE Marking Declaration of Conformity .....	52
7-3 UKCA Marking Declaration of Conformity .....	53

# Chapter 1 Introduction

---

## 1-1 Attention Marks

This instruction manual employs the following attentions marks, “**⚠ WARNING**”, “**⚠ CAUTION**” depending on the degree of the danger to call operator’s attention to each particular action. Read the following explanation of these marks thoroughly and observe these notices without fail.

**⚠ WARNING** If you ignore the advice with this mark, death or serious injury could result.

**⚠ CAUTION** If you ignore the advice with this mark, injury or material damage could result.

<Reference> It gives useful information for better use of this device.

## 1-2 Safety Precautions

- Use this device as per its specifications. Do not modify this device since its functions and capabilities may not be maintained and it may malfunction.
- This device has been developed / produced for industrial use only.
- This device is suitable for indoor use only.
- Use of this device under the following conditions or environment is not presupposed. Please consult us if there is no other choice but to use this device in such an environment.
  - 1) Operating this device under conditions or environments not described in this manual.
  - 2) Using this device in the following fields: nuclear power control, railroad, aircraft, automobiles, combustion facilities, medical systems, aerospace development, etc.
- When this device is to be used for enforcing protection of a person from any danger occurring around an operating machine, the user should satisfy the regulations established by national or regional security committees (Occupational Safety and Health Administration: OSHA, the European Standardization Committee, etc.). Contact the relative organization(s) for details.
- In case of installing this device to a particular machine, follow the safety regulations in regard to appropriate usage, mounting (installation), operation and maintenance. The users including the installation operator are responsible for the introduction of this device.
- Be sure not applying strong shock to this device. It may break this device.
- Use this device by installing suitable protection equipment as a countermeasure for failure, damage, or malfunction of this device.
- Before using this device, check whether the device performs properly with the functions and capabilities as per the design specifications.
- In case of disposal, dispose this device as an industrial waste.
- Do not use this product with mobile equipment such as an automated guided vehicle (AGV).

## ⚠ WARNING

### ◆ Machine designer, installer, employer and operator

- The machine designer, installer, employer and operator are solely responsible to ensure that all applicable legal requirements relating to the installation and the use in any application are satisfied and all instructions for installation and maintenance contained in the instruction manual are followed.
- Whether this device functions as intended to and systems including this device comply with safety regulations depends on the appropriateness of the application, installation, maintenance and operation. The machine designer, installer, employer and operator are solely responsible for these items.

### ◆ Engineer

- The engineer would be a person who is appropriately educated, has widespread knowledge and experience, and can solve various problems which may arise during work, such as a machine designer, or a person in charge of installation or operation etc.

### ◆ Operator

- The operator should read this instruction manual thoroughly, understand its contents, and perform operations following the procedures described in this manual for the correct operation of this device.
- In case this device does not perform properly, the operator should report this to the person in charge and stop the machine operation immediately. The machine must not be operated until correct performance of this device has been confirmed.

### ◆ Environment

- Do not use a mobile phone or a radio phone near this device.
- If there exists a reflective surface in the place where this device is to be installed, make sure to install this device so that reflected light from the reflective surface does not enter into the receiver, or take countermeasures such as painting, masking, roughening, or changing the material of the reflective surface, etc. Failure to do so may cause the device not to detect, resulting in death or serious injury.
- Do not install this device in the following environments.
  - 1) Areas where the light-receiving part of this device is directly exposed to light from high-frequency fluorescent lamp (inverter type) or rapid starter fluorescent lamp.
  - 2) Areas with high humidity where condensation is likely to occur
  - 3) Areas exposed to corrosive or explosive gases
  - 4) Areas exposed to vibration or shock of levels higher than that specified
  - 5) Areas exposed to contact with water
  - 6) Areas exposed to too much steam or dust

### ◆ Installation

- Always keep the correctly calculated safety distance between this device and the dangerous parts of the machine.
- Install extra protection structure around the machine so that the operator must pass through the sensing area of this device to reach the dangerous parts of the machine.
- Install this device such that some part of the operator's body always remains in the sensing area when operator is done with the dangerous parts of the machine.
- Do not install this device at a location where it can be affected by wall reflection.
- If this device is used in multiple sets, arrange them to avoid mutual interference.  
Refer to "2-3-4 Operation Test" for details.
- Do not use any reflection type or recursive reflection type arrangement.
- The corresponding emitter and receiver must have the same serial No. and be correctly oriented.

### ◆ Machine in which this device is installed

- When this device is used in the "PSDI Mode", an appropriate control circuit must be configured between this device and the machinery. For details, be sure to refer to the standards or regulations applicable in each region or country.
- In Japan and China, Korea, do not use this device as safety equipment for a press machine.
- Do not install this device with a machine whose operation cannot be stopped immediately in the middle of an operation cycle by an emergency stop equipment.
- This device starts the performance after 2 seconds from the power ON. Have the control system started to function with this timing.

### **WARNING**

#### ◆ **Wiring**

- Be sure to carry out the wiring in the power supply OFF condition.
- All electrical wiring should conform to the regional electrical regulations and laws. The wiring should be done by engineer(s) having the special electrical knowledge.
- Do not run the wires together with high-voltage lines or power lines or put them in the same raceway. This can cause malfunction due to induction.
- In case of extending the cable of the emitter or the receiver, each can be extended up to 50m by using the exclusive cable. Extending the cable longer than 50m may cause malfunction, which can result in death or serious injury.
- Use both control output (OSSD) and lockout output (SSD).
- In order that the output is not turned ON due to earth fault of control output (OSSD), be sure to ground to 0V side (PNP output) / +V side (NPN output).

#### ◆ **Maintenance**

- When replacement parts are required, always use only genuine supplied replacement parts. If substitute parts from another manufacturer are used, the device may not come to detect, result in death or serious injury.
- The periodical inspection of this device must be performed by an engineer having the special knowledge.
- After maintenance or adjustment, and before starting operation, test this device following the procedure specified in "**Chapter 4 Maintenance**".
- Clean this device with a clean cloth. Do not use any volatile chemicals.

#### ◆ **Others**

- Never modify this device. Modification may cause the device not to detect, resulting in death or serious injury.
- Do not use this device to detect objects flying over the sensing area.
- Do not use this device to detect transparent objects, translucent objects or objects smaller than the specified minimum sensing objects.



## 1-3 Regulations And Standards

This device complies with the following regulations and standards.

### <Conformity Directives / Conforming Regulations>

#### EU Directives

EU Machinery Directive 2006/42/EC

EMC Directive 2014/30/EU

RoHS Directive 2011/65/EU

#### British Legislation

Machinery Regulations 2008/1597

EMC Resolutions 2016/1091

RoHS Regulations 2012/3032

#### - Applicable Standards

EN 55011 Class A, EN 61000-6-2, EN IEC 63000

EN ISO 13849-1: 2015 (Category 2, PLc), IEC 61508-1 to 3 (SIL1)

#### <Standards in US / Canada>

ANSI/UL 61496-1/2 (Type 2), ANSI/UL 508

CAN/CSA E61496-1/2 (Type 2), CAN/CSA C22.2 No.14

#### <Regulations in US>

ANSI/RIA 15.06

#### <Other Standards>

IEC 61496-1 (Type 2), IEC 61496-2 (Type 2), ISO 13849-1:2015 (Category 2, PLc),

JIS B 9704-1/2 (Type 2), JIS B 9705-1 (Category 2), JIS C 0508 (SIL1)

Regarding EU Machinery Directive, a Notified Body, TÜV SÜD, has certified with the type examination certificate. With regard to the standards in US / Canada, TÜV SÜD, has certified for cTÜVus Mark.

#### <Reference>

The conformity to JIS, OSHA and ANSI for this device has been evaluated by ourselves.

### WARNING

- In Japan, never use this device as a safety equipment for any press machine or shearing machine.
- When this device is used in a place other than the places shown above, be sure to confirm the standards or regulations applicable in each region or country before use.

## 1-4 Confirmation of Packed Contents

- |  |                     |
|--|---------------------|
| <input type="checkbox"/> Sensor: Emitter, Receiver                                     | 1 pc. each          |
| <input type="checkbox"/> Test rod  | 1 pc.               |
| <input type="checkbox"/> <b>SF4C-TR25</b> (ø25 × 220mm)                                |                     |
| <input type="checkbox"/> Quick Instruction Manual (Japanese, English, Chinese, Korean) | 1 pc. each language |

# Chapter 2 Before Using This Device

## 2-1 Features

This device is the light curtain with the following features.

- Large multi-purpose indicators (orange) which are bright and easy-to-see are incorporated.
- Refer to “6-2 Options” for details of options.

## 2-2 Part Description

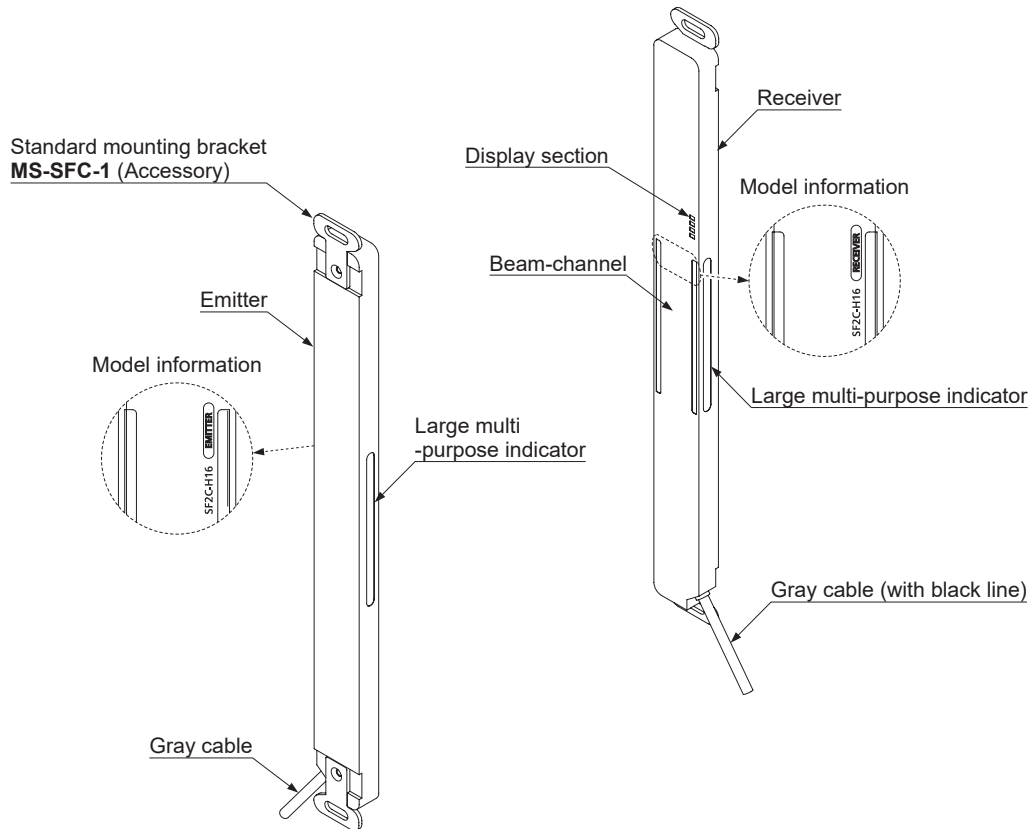

### <Emitter>

It emits light to the receiver facing it. Furthermore, the status of the emitter is indicated on its display section.

### <Receiver>

It receives light from the emitter facing it. Simultaneously, it turns ON the control output (OSSD) when the all beam channels receive light from emitter, and it turns OFF the control output (OSSD) when one or more beam channels are blocked light

Besides, the receiver displays its status on the display section.

### <Beam channel>

The light emitting elements of the emitter and the light receiving elements of the receiver are placed at the intervals of 20mm.

### <Standard mounting bracket MS-SFC-1 (Accessory)>

The mounting brackets are attached to this device. This bracket is to be used for mounting the emitter / receiver.

## <Display section>

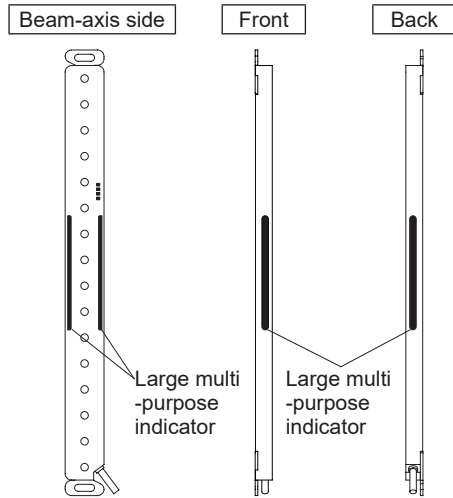

### Display section of emitter

- Operation indicator [POWER]
- Test indicator [TEST]
- Frequency setting indicator [FREQ]
- Fault indicator [FAULT]

### Display section of receiver

- OSSD indicator [OSSD]
- Unstable light reception indicator [STB]
- Frequency setting indicator [FREQ]
- Fault indicator [FAULT]

Notes: 1) Besides, 'when light is blocked' refers to the status that there exists any object blocking light in the sensing area.  
 2) The description given in [ ] is marked on the device.

## <Common for emitter and receiver>

Description	Function
Large multi-purpose indicator (Orange)	Lights up when input for the large multi-purpose indicator is valid. Turns OFF when input for the large multi-purpose indicator is invalid.
Frequency setting indicator (Orange) [FREQ]	Turns OFF when Frequency 1 is set. Lights up when Frequency 2 is set.
Fault indicator (Yellow) [FAULT]	Turns OFF during normal operation. Lights up or blinks when fault occurs in the device.

## <Emitter>

Description	Function
Operation indicator (Green) [POWER]	Lights up when device operation is as follows. Turns OFF when test input is valid.
Test indicator (Red) [TEST]	Lights up when test input is valid. Turns OFF when test input is invalid.

## <Receiver>

Description	Function
OSSD indicator (Red / Green) [OSSD]	When control output (OSSD) is OFF: lights up in red When control output (OSSD) is ON: lights up in green
Unstable light reception indicator (Orange) [STB]	Turns OFF when stable light is received (the percentage of light received is more than 150%). [Control output (OSSD) ON] Lights up when unstable light is received (the percentage of light received is between 100% and 150%). [Control output (OSSD) ON] Turns OFF when light is blocked (the percentage of light received is less than 100%) (Note 1) [Control output (OSSD) OFF]

# Protection Area

## 2-3 Protection Area

### 2-3-1 Sensing Area

 <b>WARNING</b>
<ul style="list-style-type: none"> <li>• Be sure to install protection structure around the machine so that the operator must pass through the sensing area of this device to reach the dangerous parts of the machine. Furthermore, ensure that some part of the operator's body always remains in the sensing area when operation is done with the dangerous parts of the machine. Failure to do so can result in death or serious injury.</li> <li>• Do not use any reflection type or recursive reflection type arrangement.</li> <li>• Furthermore, never use this device facing several receivers towards one emitter or vice versa.</li> </ul>

The sensing area is the zone formed by the sensing height of the device and the sensing range between the emitter and the receiver. The sensing height is determined by the number of beam channels. Furthermore, the valid range can be 0.1 to 3m. Take care that if the sensing range is less than 0.1m, malfunction may occur due to the optical structure.

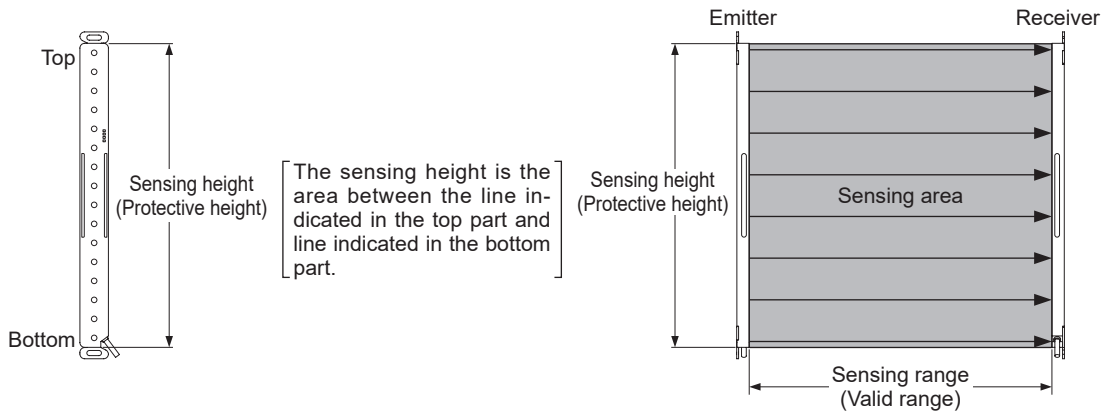

#### <Example of correct installation>

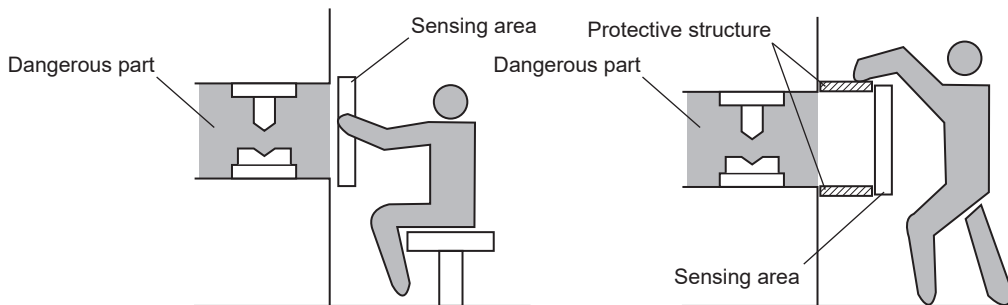

#### <Example of incorrect installation>

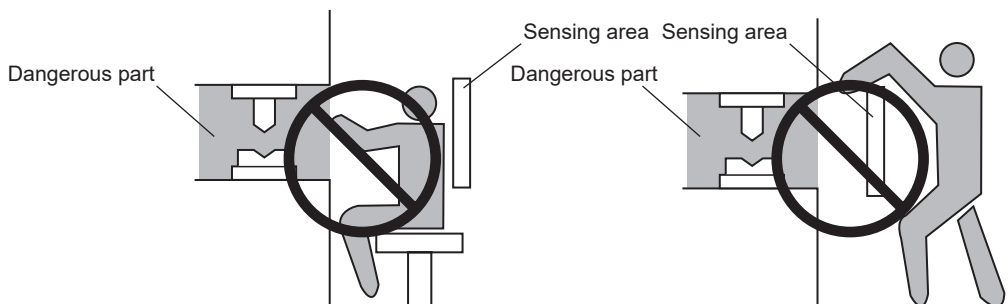

### 2-3-2 Safety Distance

#### ⚠ WARNING

- Calculate the safety distance correctly, and always maintain the distance which is equal to or greater than the safety distance, between the sensing area of this device and the dangerous parts of the machine. If the safety distance is miscalculated or if sufficient distance is not maintained, the machine will not stop quickly before reaching to the dangerous parts, which can result in death or serious injury.
- Before designing the system, refer to the relevant standards of the region where this device is to be used, and then install this device. Furthermore, the equation described in the next pages is to be used only in case the intrusion direction is perpendicular to the sensing area. In case the intrusion direction is not perpendicular to the sensing area, be sure to refer to the relevant standard (regional standard, specification of the machine, etc.) for details of the calculation.
- The max. response time of the machine is from the point that the machine receives the halt signal from this device to the point that the dangerous parts of the machine stops. The max. response time of the machine should be timed with the machine to be actually used.

The safety distance is the minimum distance that must be maintained between the device and the dangerous parts of the machine so that the machine can be stopped before a human body or an object can reach the dangerous parts.

The safety distance is calculated based on the equation described in the next page when a person moves perpendicular (normal intrusion) to the sensing area of the device.

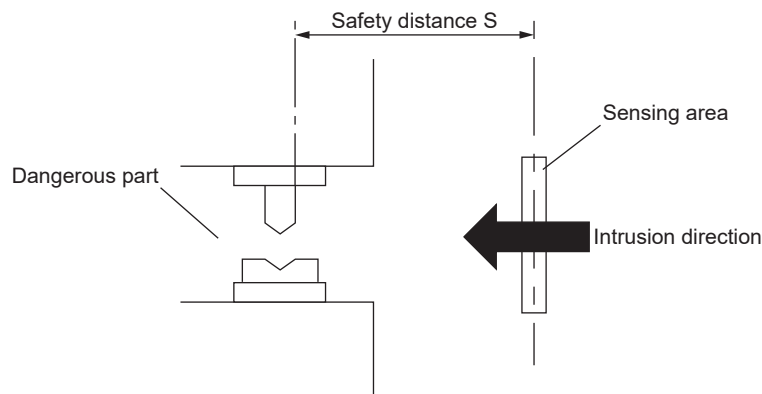

**[For use in Europe (EU) (as EN 999)] (Also applicable to ISO 13855)**  
**(For intrusion direction perpendicular to the sensing area)**  
**<In case that the minimum sensing object is ø40mm or less>**

- Equation 1  $S = K \times T + C$ 
  - S : Safety distance (mm)  
Minimum required distance between the sensing area surface and the dangerous parts of the machine
  - K : Intrusion velocity of operator's body or object (mm/s)  
Taken as 2,000 (mm/sec.) for calculation
  - T : Response time of total equipment (sec.)  
 $T = T_m + T_{SF2C}$   
T<sub>m</sub>: Maximum halting time of machine (sec.)  
T<sub>SF2C</sub>: Response time of this device (sec.)
  - C : Additional distance calculated from the size of the minimum sensing object of the device (mm)  
However, the value of C cannot be under 0.  
 $C = 8 \times (d - 14)$   
d: Minimum sensing object diameter (mm)

#### <Reference>

- For calculating the safety distance S, there are the following five cases.  
First, calculate by substituting the value K = 2,000 (mm/sec.) in the equation above. Then, classify the obtained value of S into three cases, 1)  $100 \leq S \leq 500$ , and 2)  $S > 500$ . For Case 2)  $S > 500$ , recalculate by substituting the value K = 1,600 (mm/sec.). After that, classify the calculation result into two cases, 3)  $S \leq 500$  and 4)  $S > 500$ .  
For details, refer to "Calculation example 1 For use in Europe."
- When this device is used in the 'PSDI Mode', an appropriate safety distance S must be calculated.  
For details, be sure to refer to the standards or regulations applicable in each region or country.

## Protection Area

---

### <Calculation Example>

- Calculation example 1 for use in Europe  
(OFF response time: 20ms or less, minimum sensing object diameter: 25mm)

First, calculate with  $K = 2,000$ .

$$\begin{aligned} S &= K \times T + C \\ &= K \times (T_m + T_{SF2C}) + 8 \times (d - 14) \\ &= 2,000 \times (T_m + 0.020) + 8 \times (25 - 14) \\ &= 2,000 \times T_m + 2,000 \times 0.020 + 8 \times 11 \\ &= 2,000 \times T_m + 40 + 88 \\ &= 2,000 \times T_m + 128 \end{aligned}$$

If the result is:

- 1) In case  $100 \leq S \leq 500$  (mm)  
Safety distance  $S$  is taken as  $2,000 \times T_m + 128$  (mm)
- 2) In case  $S > 500$  (mm)  
$$\begin{aligned} S &= K \times (T_m + T_{SF2C}) + 8 \times (d - 14) \\ &= 1,600 \times (T_m + 0.020) + 8 \times (25 - 14) \\ &= 1,600 \times T_m + 1,600 \times 0.020 + 8 \times 11 \\ &= 1,600 \times T_m + 32 + 88 \\ &= 1,600 \times T_m + 120 \end{aligned}$$

then, calculate again.

If the result is:

- 3) In case  $S \leq 500$  (mm)  
Safety distance  $S$  is taken as 500 (mm)
- 4) 5) In case  $S > 500$  (mm)  
Safety distance  $S$  is taken as  $1,600 \times T_m + 120$  (mm)

In case this device is installed in a system with a maximum halting time 0.1 (sec.)

$$\begin{aligned} S &= 2,000 \times T_m + 128 \\ &= 2,000 \times 0.1 + 128 \\ &= 328 \end{aligned}$$

Since this value matches with Case 1) above,  $S$  is 328 (mm).

In case this device is installed in a system with a maximum halting time 0.4 (sec.)

$$\begin{aligned} S &= 2,000 \times T_m + 128 \\ &= 2,000 \times 0.4 + 128 \\ &= 928 \end{aligned}$$

Since this value matches with the case 2) above,

$$\begin{aligned} S &= 1,600 \times T_m + 120 \\ &= 1,600 \times 0.4 + 120 \\ &= 760 \end{aligned}$$

Since this value matches with Case 4) above,  $S$  is 760 (mm)

**[For use in the United States of America (as per ANSI/RIA 15.06)]**

- Equation 2  $D_s = K \times (T_s + T_c + T_{SF2C} + T_{bm}) + D_{pf}$ 
  - $D_s$  : Safety distance (mm)  
Minimum required distance between the sensing area surface and the dangerous parts of the machine
  - $K$  : Intrusion speed {Recommended value in OSHA is 63 (inch/sec.) [ $\approx$  1,600 (mm/sec.)] }  
ANSI/RIA 15.06 does not define the intrusion speed “K.” When determining K, consider possible factors including physical ability of operators.
  - $T_s$  : Halting time calculated from the operation time of the control element (air valve, etc.) (sec.)
  - $T_c$  : Maximum response time of the control circuit required for functioning the brake (sec.)
  - $T_{SF2C}$ : Response time of this device (sec.)
  - $T_{bm}$  : Additional halting time tolerance for the brake monitor (sec.)  
The following equation holds when the machine is equipped with a brake monitor.  
 $T_{bm} = T_a - (T_s + T_c)$   
 $T_a$ : Setting time of brake monitor (sec.)  
When the machine is not equipped with a brake monitor, it is recommended that 20% or more of ( $T_s + T_c$ ) is taken as additional halting time.
  - $D_{pf}$  : Additional distance calculated from the size of the minimum sensing object of the device (mm)  
 $D_{pf} = 61.2\text{mm}$   

$D_{pf} = 3.4 \times (d - 0.276)$ (inch) $\approx 3.4 \times (d - 7)$ (mm)
---

  
 $d$ : Minimum sensing object diameter 0.985 (inch)  $\approx$  25 (mm)

**<Calculation Example>**

- Calculation example 2: For use in the United States of America  
[OFF response time: 20ms or less, minimum sensing object diameter: 0.985 (inch)  $\approx$  25 (mm)]

$$\begin{aligned}
 D_s &= K \times (T_s + T_c + T_{SF2C} + T_{bm}) + D_{pf} \\
 &= 63 \times (T_a + 0.020) + 3.4 \times (d - 0.276) \text{ (inch)} \\
 &= 63 \times (T_a + 0.020) + 3.4 \times (0.985 - 0.276) \\
 &= 63 \times T_a + 63 \times 0.020 + 3.4 \times 0.709 \\
 &= 63 \times T_a + 1.26 + 2.4106 \\
 &= 63 \times T_a + 3.6706 \\
 &\approx 63 \times T_a + 3.68 \text{ (inch)}
 \end{aligned}$$

In case this device is installed in a system with a maximum halting time 0.1 (sec.)

$$\begin{aligned}
 D_s &= 63 \times T_a + 3.68 \\
 &= 63 \times 0.1 + 3.68 \\
 &= 9.98 \text{ (inch)} \\
 &\approx 253.49 \text{ (mm)}
 \end{aligned}$$

Hence, as per the calculations S is 253.5 (mm).

**<Reference>**

Since the calculation above is performed by taking 1 (inch) = 25.4 (mm), there is a slight difference between the representation in (mm) and that in (inch).  
Refer to the relevant standard for the details.

## Protection Area

### 2-3-3 Influence of Reflective Surfaces

#### **WARNING**

If there exists a reflective surface in the place where this device is to be installed, make sure to install this device so that reflected light from the reflective surface does not enter into the receiver, or take countermeasures such as painting, masking, roughening, or changing the material of the reflective surface, etc. Failure to do so may cause the device not to detect, resulting in death or serious injury.

Install this device at a distance of at least 0.32 (m) (given below) away from reflective surfaces such as metal walls, floors, ceilings, sensing objects, covers, panels or glass surfaces.

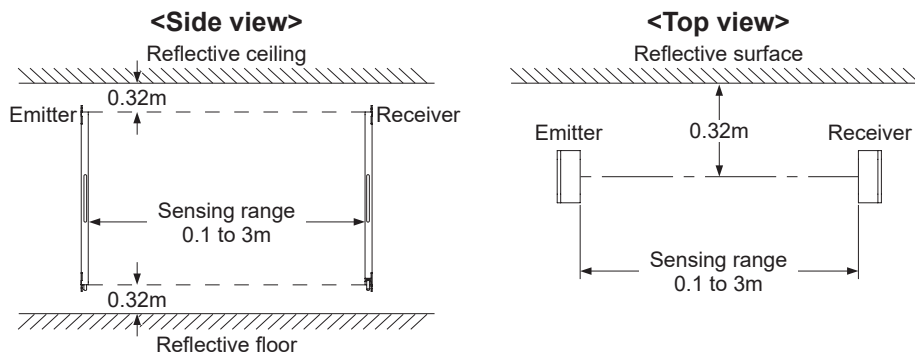



### 2-3-4 Device Placement

This is the placement method by which two or more sets of emitters and receivers are placed face to face. It is used for system evaluation in case of addition of equipment.  
Perform an operation test by referring to “2-6-2 Operation Test.”

<b>⚠ WARNING</b>
<ul style="list-style-type: none"> <li>• Refer to the examples of device placement given below and understand them thoroughly before installing the devices. Improper sensor placement could cause device malfunction, which can result in death or serious injury.</li> <li>• If this device is used in multiple sets, arrange them to avoid mutual interference. If mutual interference occurs, it can result in death or serious injury.</li> </ul>

#### <Example of device placement>

<p>1) Install the emitter and the receiver back to back</p>	<p>2) Arrange the emitter and the receiver vertically on opposite sides.</p>
<p>3) Arrange the emitter and the receiver horizontally on opposite sides.</p>	<p>4) Install a barrier</p>

<p><b>&lt;Reference&gt;</b> The above figures are just examples of device placement. If there are any questions or problems, please contact our office.</p>
---

<b>WARNING</b>
<p>Position the emitter and receiver so that their cables are aligned. Failure to do so will cause the system to malfunction.</p>

# Mounting

## 2-4 Mounting

### 2-4-1 Mounting of the Mounting Bracket

#### ⚠ CAUTION

- Do not apply the load such as forced bending to the cable of this device. Applying improper load could cause the wire breakage.
- The minimum bending radius of the cable is R5mm. Mount the device considering the cable bending radius.

#### <Reference>

- Mount the emitter and the receiver at the same level and parallel to each other. The effective aperture angle of this device is  $\pm 5^\circ$  or less for a sensing distance of 3m or more.
- Unless otherwise specified, the following mounting procedure is common for both emitter and receiver. For the preparation of the mounting, prepare the mounting holes on the mounting surface by referring to “6-3 Dimensions .”

#### <In case of using standard mounting bracket (MS-SFC-1) (accessory)>

- Direction of the standard mounting bracket **MS-SFC-1** which is attached to this device can be changed depending on the mounting position of the device.

Step 1. Remove the M3 countersunk head screw [with anti-loosening agent (length 4mm)] which is attached to the back of the device.

Step 2. Decide the direction of the standard mounting bracket.

Step 3. Tighten with the M3 countersunk head screw [with anti-loosening agent (length 4mm)]. The tightening torque should be 0.3 N•m or less.

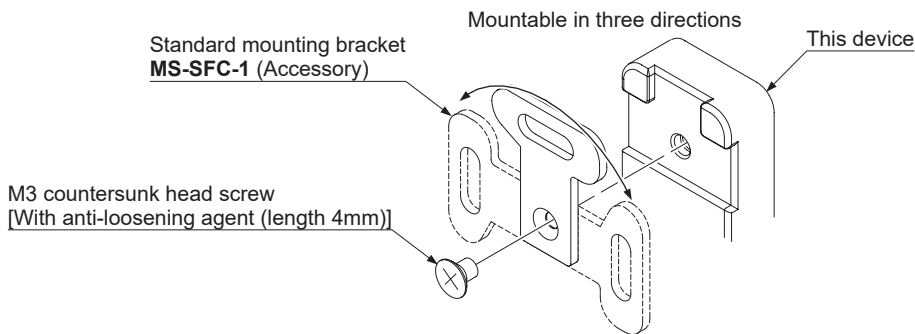

- Set the standard mounting bracket that is ready for setting to the mounting surface using two hexagon-socket head bolts [M5 (please arrange separately)].

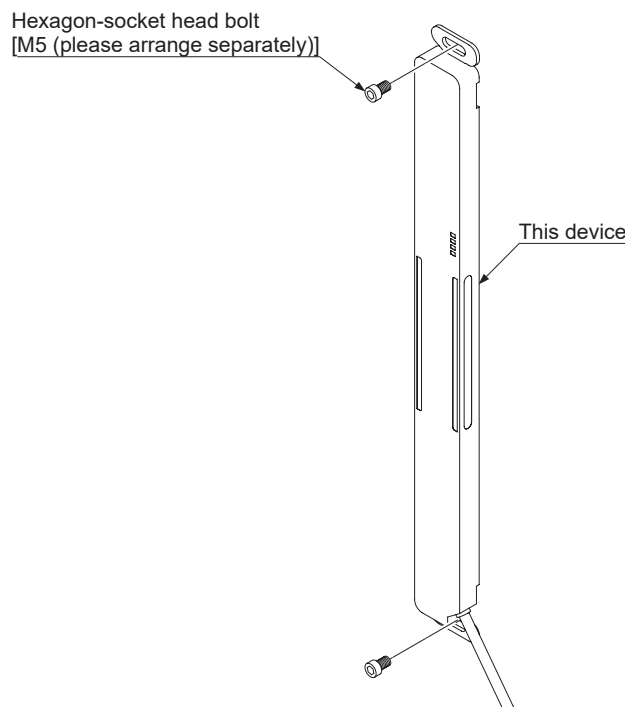

Note: The case of the product is made of resin so the longitudinal dimension is subject to expansion and contraction. When drilling mounting holes, check the drilling locations by positioning the actual product at the installation location.

**<In case of using multifunctional mounting bracket (MS-SFC-3) (optional)>**

Step 1 Removing the M3 countersunk head screw [with anti-loosening agent (length 4mm)] which is attached to the back of the device. And remove the standard mounting bracket **MS-SFC-1** (accessory)

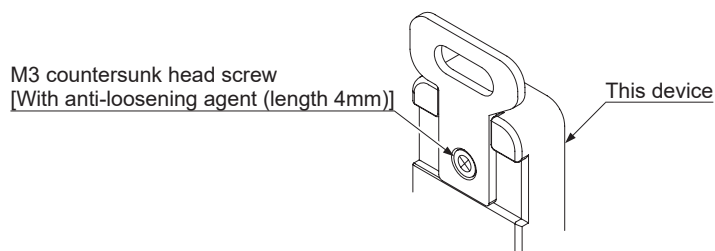

Step 2 Tighten with the M3 countersunk head screw [with anti-loosening agent (length 4mm)]. The tightening torque should be 0.3 N·m or less.

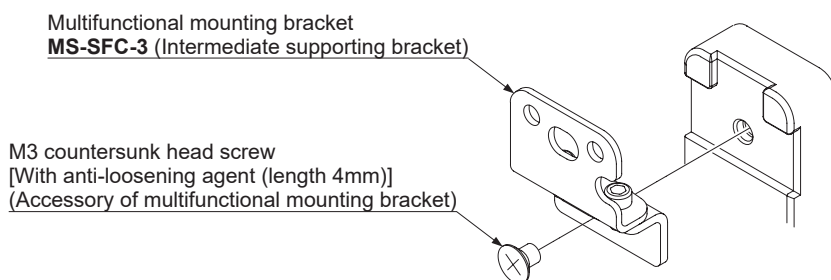

Step 3 Set the multifunctional mounting bracket on the mounting surface using either two hexagon head bolts [M6 (purchase separately)] or four hexagon head bolts [M4 (purchase separately)].

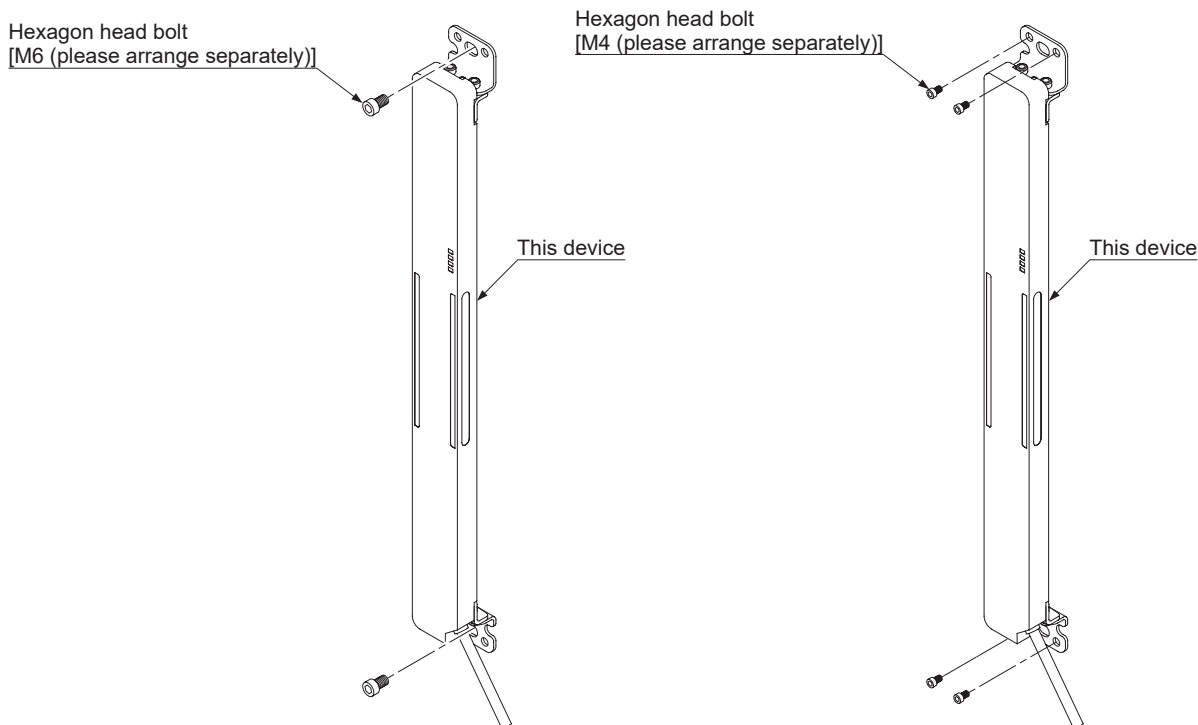

Note: **SF2C-H28** and **SF2C-H32** require multifunctional intermediate supporting bracket **MS-SFC-4** (optional). Refer to **<In case using multifunctional intermediate supporting bracket MS-SFC-4 (Optional)>** for the mounting method.

## Mounting

<In case of using multifunctional mounting bracket MS-SFC-3 (optional) as dead space less mounting bracket>

Step 1 Removing the M3 countersunk head screw [with anti-loosening agent (length 4mm)] which is attached to the back of the device. And remove the standard mounting bracket **MS-SFC-1** (accessory)

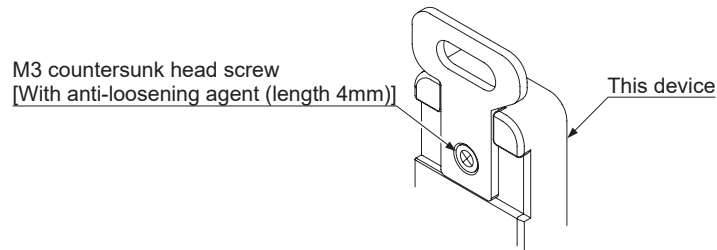

Step 2 Tighten with the M3 countersunk head screw [with anti-loosening agent (length 4mm)]. The tightening torque should be 0.3 N•m or less.

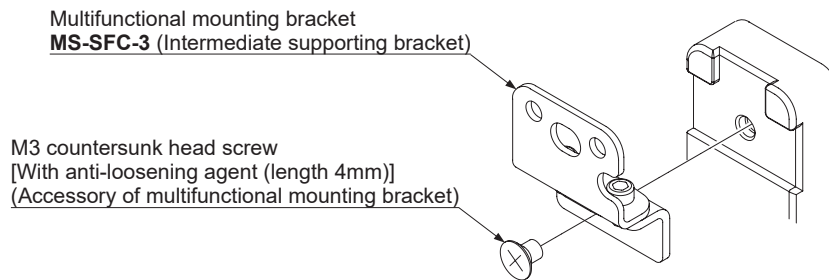

Step 3 Remove two of hexagon-socket head bolts for beam-axis alignment M3 (length 5mm)].

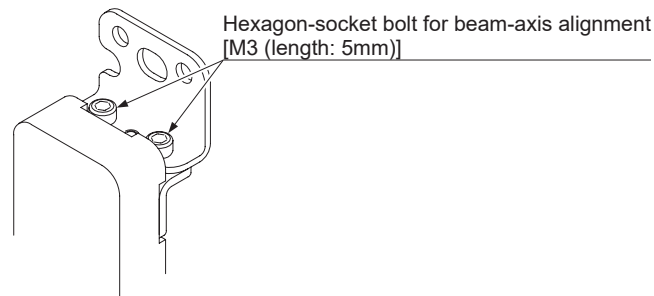

Step 4 Change direction of the part A of multifunctional mounting bracket. And tighten the two of hexagon-socket head bolts for beam-axis alignment M3 (length 5mm)]. The tightening torque should be 2 N•m or less.

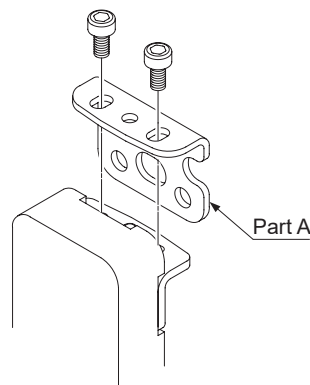

Step 5 Set the multifunctional mounting bracket on the mounting surface using either two hexagon head bolts [M6 (purchase separately)] or four hexagon head bolts [M4 (purchase separately)].

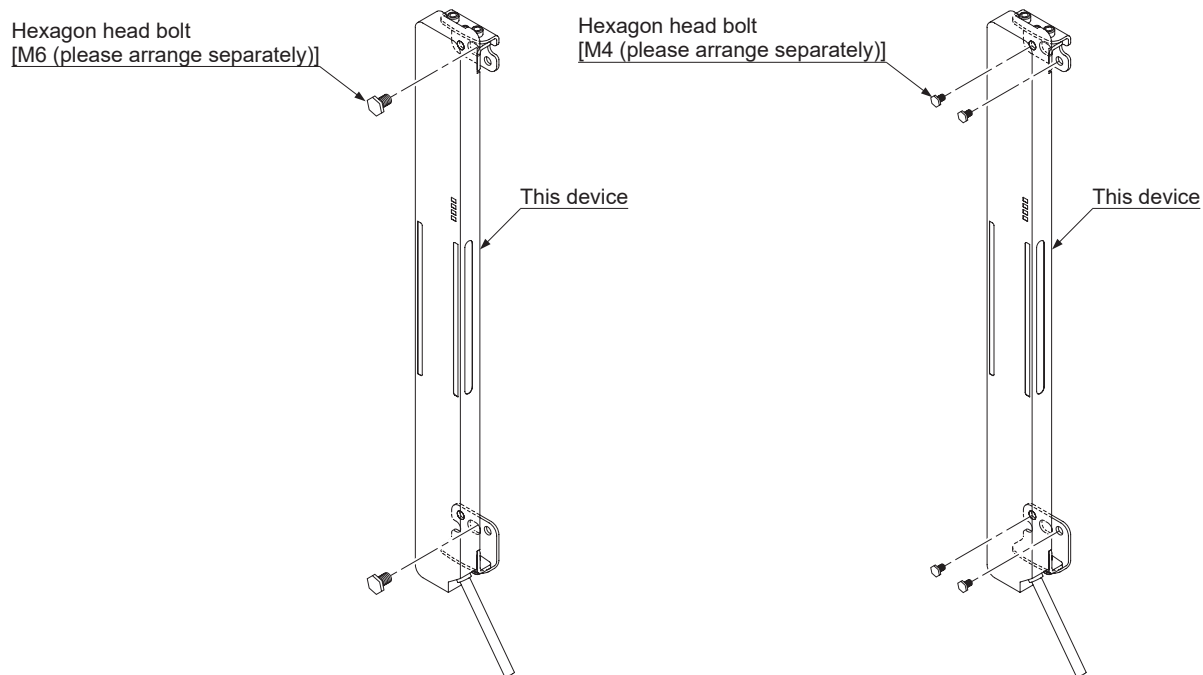

Note: **SF2C-H28** and **SF2C-H32** require multifunctional intermediate supporting bracket **MS-SFC-4** (optional).  
Refer to <In case using multifunctional intermediate supporting bracket **MS-SFC-4** (Optional)> for the mounting method.

## Mounting

### <In case of using standard mounting bracket (MS-SFC-4) (optional)>

Step 1 Be sure mounting bracket is not mounted on this device. And set in the multifunctional intermediate supporting bracket **MS-SFC-4** (optional) from top or end of this device.

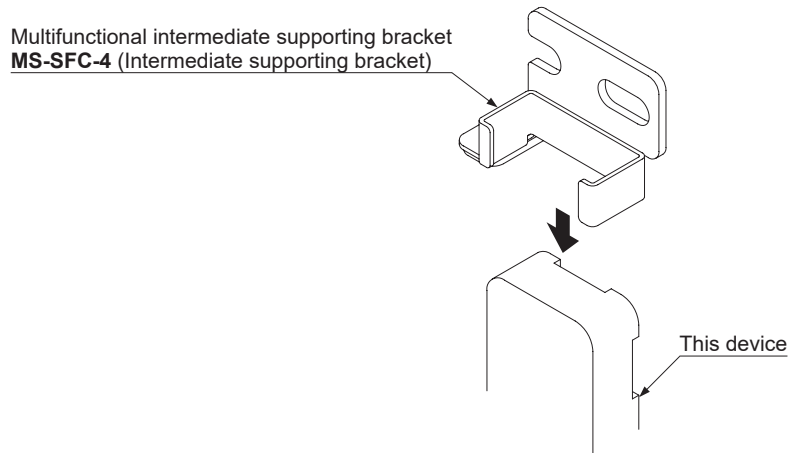

Step 2 Set the multifunctional intermediate supporting bracket on the mounting surface using a hexagon head bolt [M6 (purchase separately)] or a hexagon-socket head bolt [M6 (purchase separately)].

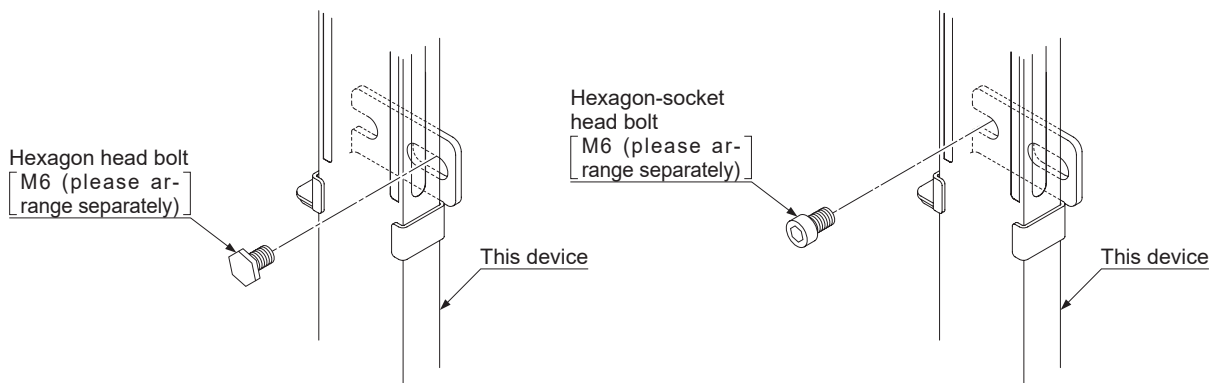

Note: Refer to <In case of using multifunctional mounting bracket **MS-SFC-3** (optional)> or <In case of using multifunctional mounting bracket **MS-SFC-3** (optional) as dead space less mounting bracket> for details of the mounting method of the multifunctional mounting bracket **MS-SFC-3** (optional).

### CAUTION

Use the multifunctional intermediate supporting bracket **MS-SFC-4** (optional) in combination with the multifunctional mounting bracket **MS-SFC-3** (optional). It cannot be mounted in combination the standard mounting bracket **MS-SFC-1** (accessory).

**<In case of using protective metal case (MS-SFCH-□) (optional)>**

Step 1 Confirm a state that the standard mounting bracket **MS-SFC-1** (accessory), mounted to this device, is center mounting. And set in protective metal Case from top of this device.

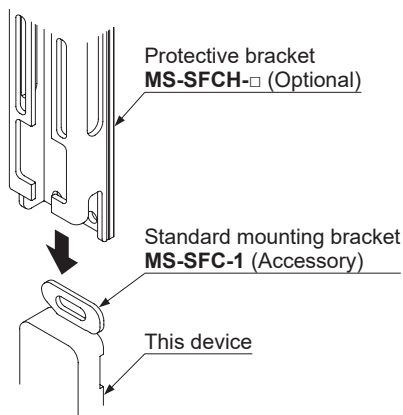

Step 2 Position mounting holes of protective metal Case and standard mounting bracket. And, tighten with two hexagon-socket head bolts [M5 (purchase separately)] on the mounting surface.

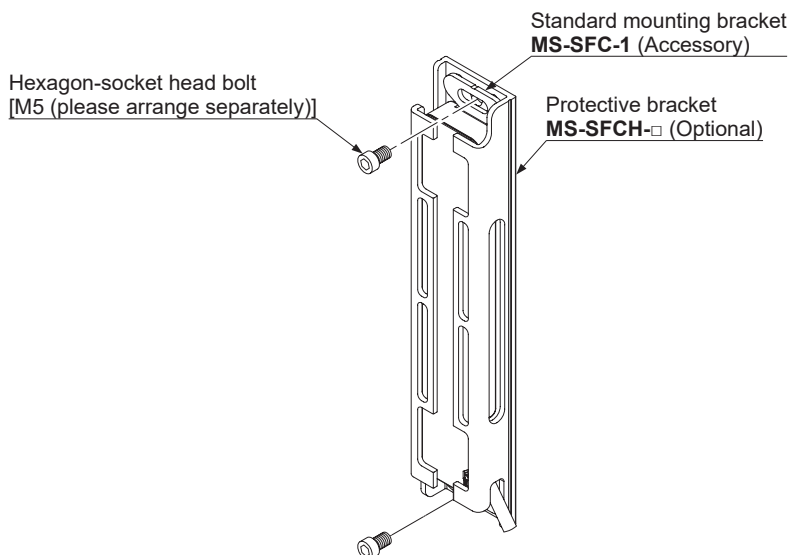

## CAUTION

- Use the protective metal case **MS-SFCH-□** (optional) in combination with the standard mounting bracket **MS-SFC-1** (accessory). It cannot be mounted in combination with the multifunctional mounting bracket **MS-SFC-3** (optional).
- When mounting the protective metal case **MS-SFCH-□** (optional) to this device, make sure the state that the standard mounting bracket **MS-SFC-1** (accessory) is mounted in center of this device. When the standard mounting bracket **MS-SFC-1** (accessory) is mounted as the dead space less mounting, the protective metal case **MS-SFCH-□** (optional) can not be mounted to this device.

### 2-5 Wiring

#### **WARNING**

- Earth the machine or the support where the device is mounted on to frame ground (F.G.). Failure to do so could cause the malfunction of the device by noise, resulting in death or serious injury. Furthermore, the wiring should be done in a metal box connected to the frame ground (F.G.).
- Take countermeasure against the system to be applied for this device so as not to carry out the dangerous performance caused by the earth failure.  
Failure to do so could cause invalid for the system stop, resulting in death or serious injury.
- In order that the output is not turned ON due to earth fault of control output (OSSD), be sure to ground to 0V side (PNP output) / +V side (NPN output).

#### **CAUTION**

Make sure to insulate the ends of the unused lead wires.

#### <Reference>

Use a safety relay unit or an equivalent control circuit in safety for FSD.

### 2-5-1 Power Supply Unit

#### **CAUTION**

Wire correctly using a power supply unit which conforms to the laws and standards of the region where this device is to be used.

If the power supply unit is non-conforming or the wiring is improper, it can cause damage or malfunction of this device.

#### <Reference>

A specialist who has the required electrical knowledge should perform the wiring.

The power supply unit must satisfy the conditions given below.

- 1) Power supply unit authorized in the region where this device is to be used.
- 2) Power supply unit SELV (safety extra low voltage) / PELV (protected extra low voltage) conforming to EMC Directive and Low-voltage Directive (only for requiring CE marking conformation).
- 3) The power supply unit must be a SELV (safety extra low voltage) / PELV (protected extra low voltage) unit that conforms to the EMC Regulations and Electrical Equipment (Safety) Regulations. (When UKCA marking is required.)
- 4) The frame ground (F.G.) terminal must be connected to ground when using a commercially available switching regulator.
- 5) Power supply unit with an output holding time of 20ms or more.
- 6) In case a surge is generated, take countermeasures such as connecting a surge absorber to the origin of the surge.
- 7) Power supply unit corresponding to CLASS 2 (only for requiring cTÜVus Mark conformation).



2-5-2 I/O Circuit Diagrams

<PNP output type / SF2C-H□-P>

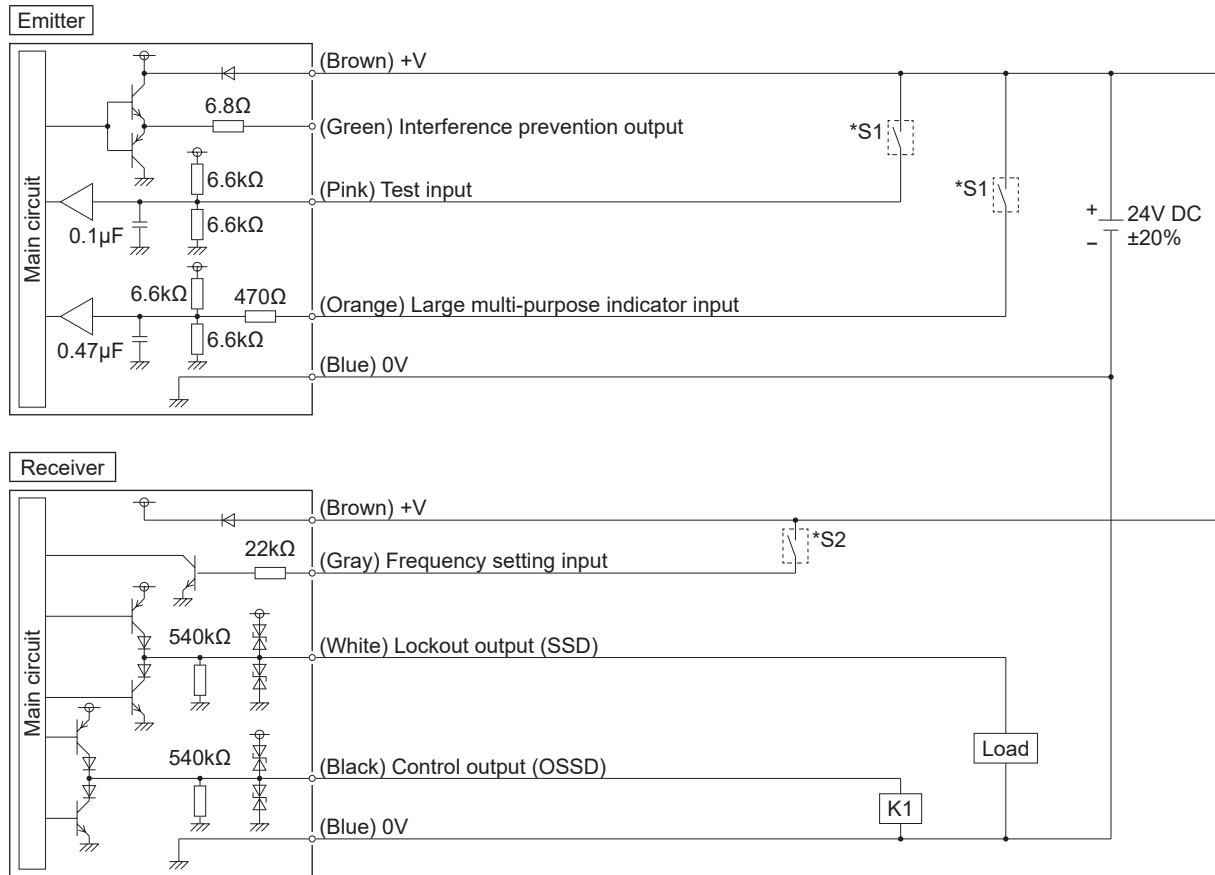

**\*Switch**

- Switch: S1
- Test input, Large multi-purpose indicator input  
ON:  $V_s - 2.5V$  to  $V_s$   
OFF: Open
  - Frequency setting input  
Frequency 1 setting: Open  
Frequency 2 setting: +V

**<Reference>**

K1: External device (Forced guided relay or magnetic contactor)

- Notes: 1) The orange indicator lights up when the input wire for the large multi-purpose indicator (orange) is connected to the +V terminal, and turns OFF when it is disconnected.  
2)  $V_s$  is the applying supply voltage.

# Wiring

## <NPN output type / SF2C-H□-N>

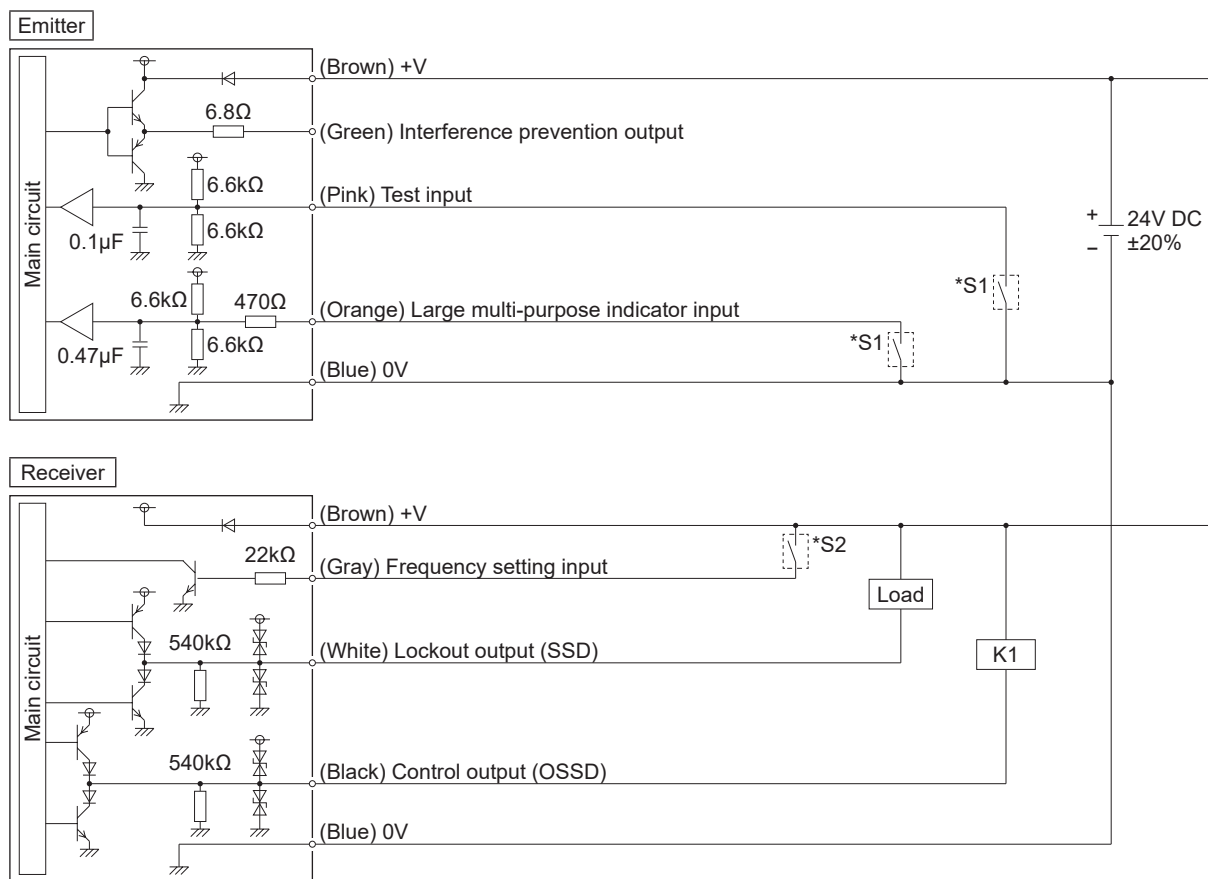

### \*Switch

- Switch: S1
- Test input, Large multi-purpose indicator input  
ON: 0 to +2.5V  
OFF: Open
  - Frequency setting input  
Frequency 1 setting: Open  
Frequency 2 setting: +V

### <Reference>

K1: External device (Forced guided relay or magnetic contactor)

Note: The orange indicator lights up when the input wire for the large multi-purpose indicator (orange) is connected to the 0V terminal, and turns OFF when it is disconnected.

### 2-5-3 Basic Wiring

This is the general configuration using one set of the emitter and receiver facing each other. The control output (OSSD) turns OFF if the light is blocked, while it turns ON if received the light.

#### <PNP output type / SF2C-H□-P>

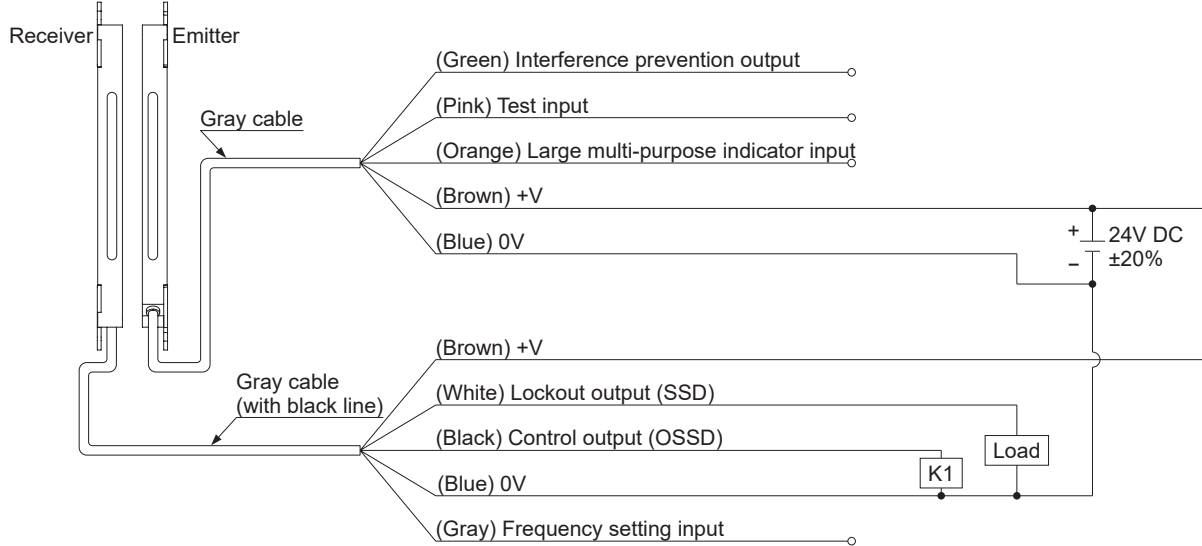

#### <NPN output type / SF2C-H□-N>

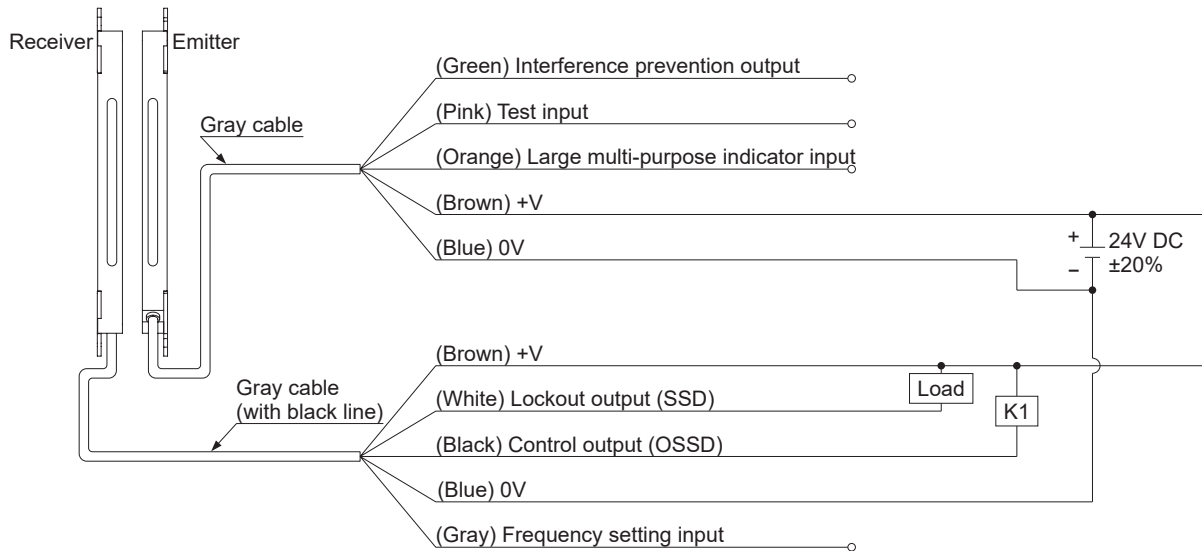

**2-5-4 Wiring for Test Input Function / Large Multi-purpose Indicator Function / Interference Prevention Function**

<PNP output type / SF2C-H□-P>

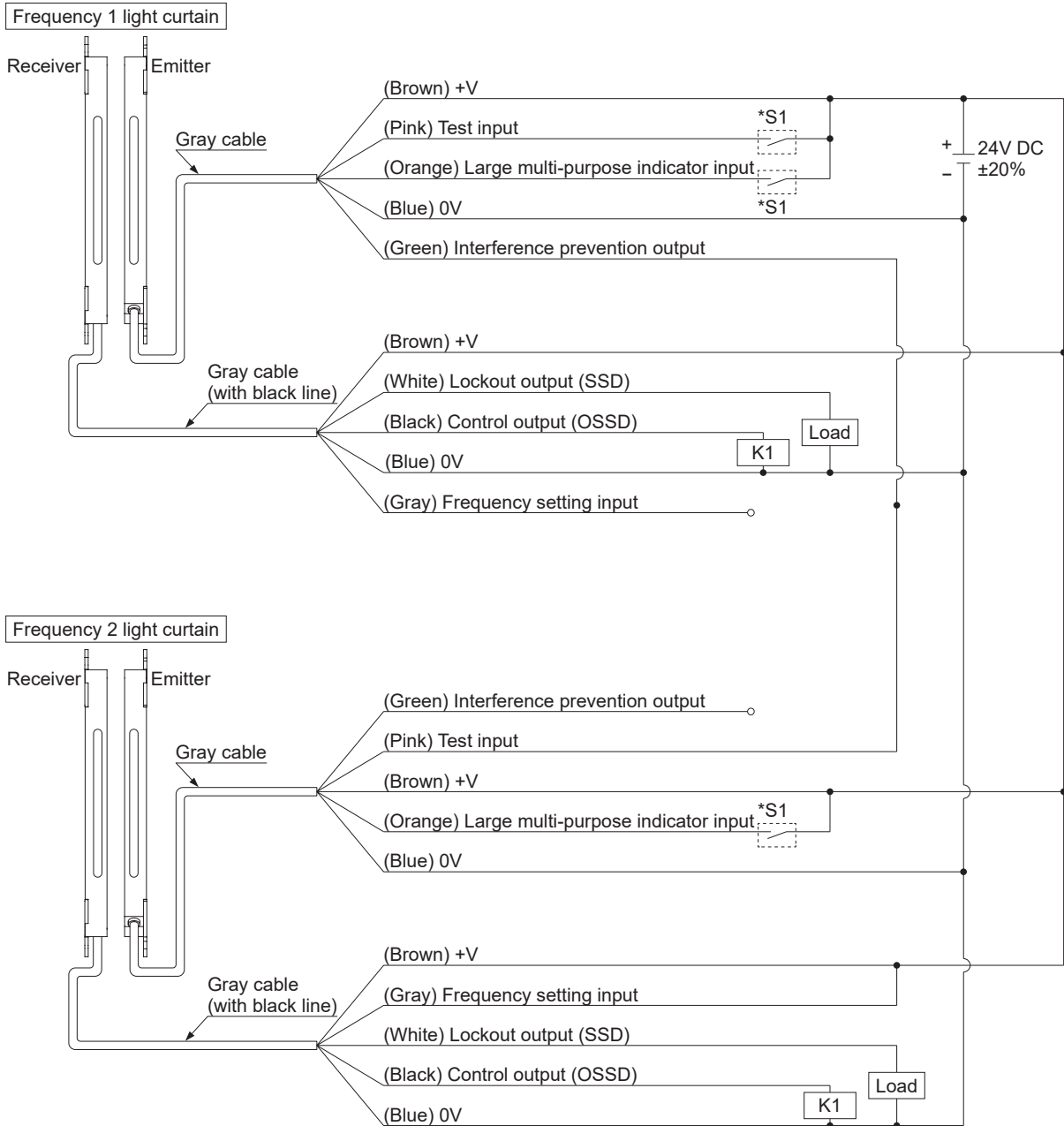

**\*S1**  
 ON:  $V_s - 2.5V$  to  $V_s$   
 OFF: Open

**Frequency setting input**  
 Frequency 1 setting: Open  
 Frequency 2 setting: +V

**<Reference>**  
 K1: External device (Forced guided relay or magnetic contactor)

Notes: 1) The orange indicator lights up when the input wire for the large multi-purpose indicator (orange) is connected to the +V terminal, and turns OFF when it is disconnected.  
 2)  $V_s$  is the applying supply voltage.

<NPN output type / SF2C-H□-N>

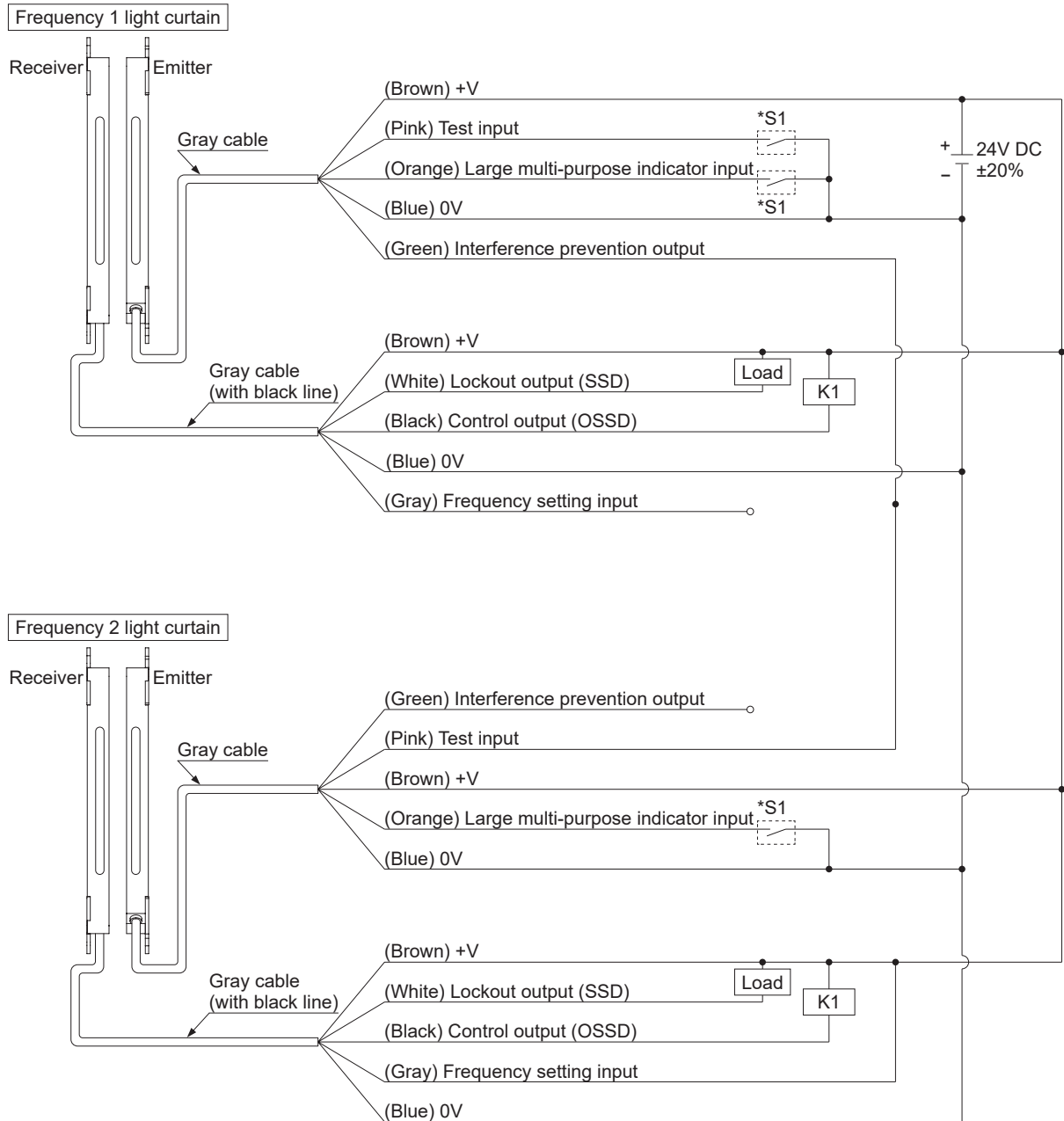

\*S1

ON: 0 to +2.5V  
OFF: Open

Frequency setting input

Frequency 1 setting: Open  
Frequency 2 setting: +V

<Reference>

K1: External device (Forced guided relay or magnetic contactor)

Note: The orange indicator lights up when the input wire for the large multi-purpose indicator (orange) is connected to the 0V terminal, and turns OFF when it is disconnected.

# Adjustment

## 2-6 Adjustment

### 2-6-1 Beam-axis alignment

- Step 1 Turn ON the power supply unit of this device.
- Step 2 Check that the digital error indicator (red) and the fault indicator (yellow) of the emitter and the receiver are OFF respectively.
  - If the digital error indicator (red) or the fault indicator (yellow) lights up or blinks, refer to “Chapter 5 Troubleshooting” and report the symptoms to the maintenance in charge.

#### [In case of using the standard mounting bracket MS-SFC-1 (accessory)]

- Step 3 Loosen the hexagon-socket head bolts [M5 (purchase separately)] which holds the standard mounting bracket **MS-SFC-1**.
- Step 4 Adjust the position of the receiver by moving it horizontally until light is received.
- Step 5 Similar to the step 4, perform the beam-axis alignment for the receiver.
- Step 6 Tighten the standard mounting bracket **MS-SFC-1** by the hexagon-socket head bolt [M5 (purchase separately)].
- Step 7 Check the operation indicator (green) on the emitter and the OSSD indicator (green) on the receiver are both lit.

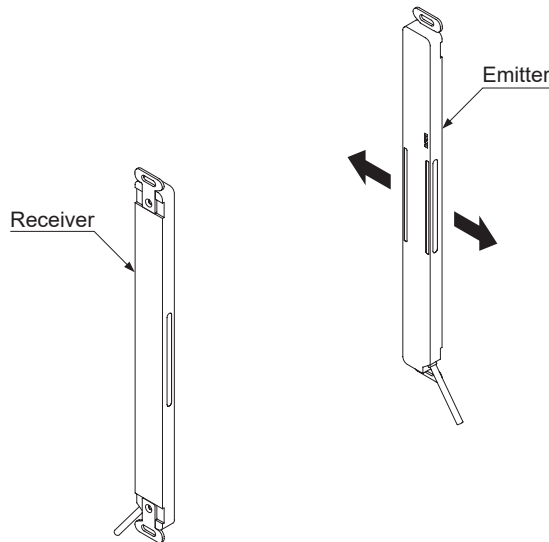

#### [In case of using the multifunctional mounting bracket MS-SFC-3 (optional) and the multifunctional intermediate supporting bracket MS-SFC-4 (optional)]

- Step 3 Loosen the four hexagon-socket bolts for beam-axis alignment [M3 (length: 5 mm)] on the multifunctional mounting bracket **MS-SFC-3**.
- Step 4 If the multifunctional intermediate supporting bracket **MS-SFC-4** has been mounted, loosen one of the hexagon-socket bolts for beam-axis alignment [M3 (length: 5 mm)] on the multifunctional intermediate supporting bracket.

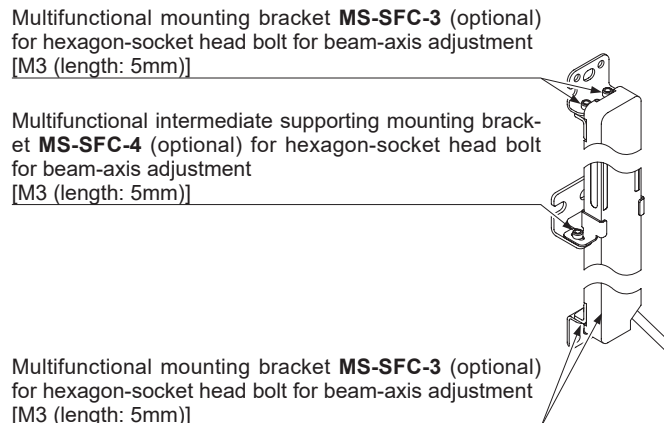

- Step 5 Rotate the emitter and the receiver to adjust their positions.  
The emitter and the receiver can be fine-adjusted by  $\pm 5$  degrees.

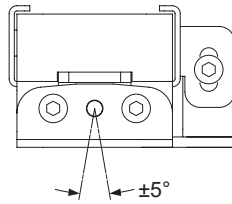

- Step 6 After the adjustment, tighten the hexagon-socket head bolt for beam-axis alignment of the standard mounting bracket. The tightening torque should be 2 N·m or less.
- Step 7 Tighten the hexagon-socket head bolt of the multifunctional intermediate supporting brackets [M3 (length: 5mm)].
- Step 8 Check the operation indicator (green) on the emitter and the OSSD indicator (green) on the receiver are both lit.

## CAUTION

After beam-axis alignment, confirm that all bolts are tightened at stated torque. Refer to “2-4 Mounting” for each tightening torque of the bolts.

### 2-6-2 Operation Test

- Step 1 Turn ON the power supply unit of this device.
- Step 2 Check that the fault indicator (yellow) of the emitter and the receiver are OFF respectively.
- If the fault indicator (yellow) lights up or blinks, refer to “Chapter 5 Troubleshooting” and report the symptoms to the maintenance in charge.
- Step 3 Move the test rod ( $\varnothing 25\text{mm}$ ) up and down 1,600 mm/sec. or less at three positions, just in front of the emitter (A), between the emitter and receiver (B) and just in front of the receiver (C).

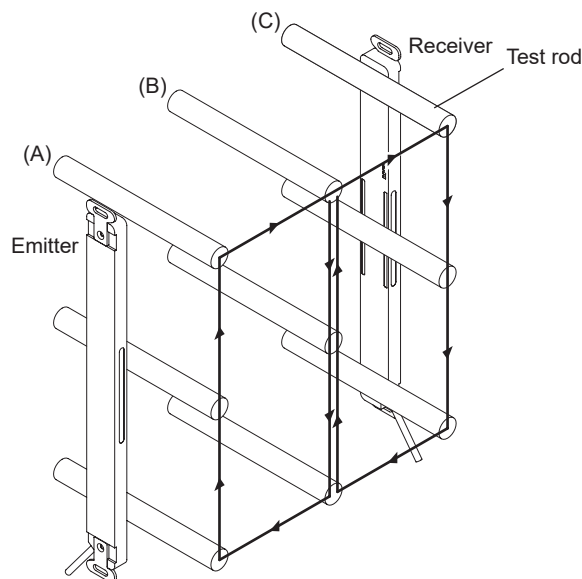

- Step 4 During Step 3 above, check that the control output (OSSD) is in OFF state, and both the OSSD indicator (red) of the receiver light up as long as the test rod is present within the sensing area.
- If the behavior of the control output (OSSD) and the turning ON / OFF of the emitter / receiver indicators do not correspond to the movement of the test rod, refer to “Chapter 5 Troubleshooting” and report the symptoms to the maintenance in charge.

#### <Reference>

If the indicators show reception of the light even though the test rod blocks the light, check whether there is any reflective object or extraneous light source near this device or not.

# Adjustment

## 2-6-3 Operation

### 1) Normal Operation

The status of the emitter / receiver indicators during normal operation is as described below.

■: Lights up in red, ■: Lights up in green, □: Turns OFF

State of this device	Indicators		Control output (OSSD)	Lockout output (SSD)
	Emitter	Receiver		
Before power is ON	<input type="checkbox"/> POWER <input type="checkbox"/> TEST <input type="checkbox"/> FREQ <input type="checkbox"/> FAULT	<input type="checkbox"/> OSSD <input type="checkbox"/> STB <input type="checkbox"/> FREQ <input type="checkbox"/> FAULT	OFF	OFF
After power is ON Light received status (all beams received)	<input checked="" type="checkbox"/> POWER <input type="checkbox"/> TEST <input type="checkbox"/> FREQ <input type="checkbox"/> FAULT	<input checked="" type="checkbox"/> OSSD <input type="checkbox"/> STB <input type="checkbox"/> FREQ <input type="checkbox"/> FAULT	ON	ON
After power is ON Light blocked status One or more beams blocked	<input checked="" type="checkbox"/> POWER <input type="checkbox"/> TEST <input type="checkbox"/> FREQ <input type="checkbox"/> FAULT	<input checked="" type="checkbox"/> OSSD <input type="checkbox"/> STB <input type="checkbox"/> FREQ <input type="checkbox"/> FAULT	OFF	ON
Timing chart	<p>The timing chart shows three signals over time:</p> <ul style="list-style-type: none"> <li><b>Power supply:</b> Transitions from OFF to ON. A 2-second delay (or less) occurs before the light received status changes.</li> <li><b>Light received status:</b> Transitions from OFF to ON (Light received) and back to OFF (Light blocked).</li> <li><b>Control output (OSSD):</b> Transitions from OFF to ON (80 to 100ms delay) when light is received, and back to OFF (20ms or less delay) when light is blocked.</li> </ul>			

### 2) When using test input function

This device incorporates the test input function. Using this function, it is possible to simulate the light blocked status.

#### <Reference>

When the test input / reset input is kept short-circuit, the test input function will be valid and the receiver will be OFF with the emitting light is received.

■: Lights up in red, ■: Lights up in green, □: Turns OFF





Setting procedure and check items	Indicators		Control output (OSSD)	Lockout output (SSD)
	Emitter	Receiver		
1 Receiver's control output (OSSD) is ON (Normal operation)	<input checked="" type="checkbox"/> POWER <input type="checkbox"/> TEST <input type="checkbox"/> FREQ <input type="checkbox"/> FAULT	<input checked="" type="checkbox"/> OSSD <input type="checkbox"/> STB <input type="checkbox"/> FREQ <input type="checkbox"/> FAULT	ON	ON
2 Short-circuit the test input / reset input Receiver's control output (OSSD) is OFF (Test input valid) (Normal operation)	<input type="checkbox"/> POWER <input checked="" type="checkbox"/> TEST <input type="checkbox"/> FREQ <input type="checkbox"/> FAULT	<input checked="" type="checkbox"/> OSSD <input type="checkbox"/> STB <input type="checkbox"/> FREQ <input type="checkbox"/> FAULT	OFF	ON
3 Open the test input / reset input Receiver's control output (OSSD) is ON (Normal operation)	<input checked="" type="checkbox"/> POWER <input type="checkbox"/> TEST <input type="checkbox"/> FREQ <input type="checkbox"/> FAULT	<input checked="" type="checkbox"/> OSSD <input type="checkbox"/> STB <input type="checkbox"/> FREQ <input type="checkbox"/> FAULT	ON	ON







**3) When an error occurs**

If an error is detected in this device, it will enter a lockout state.

- If an error is detected in the emitter, the emitter and the receiver will enter a lockout state, and control output (OSSD) and lockout output (SSD) will turn OFF. Also, the fault indicator (yellow) on the emitter will light up or blink, and the fault indicator (yellow) and the unstable light reception indicator (orange) blink alternately.
- If an error is detected in the receiver, the receiver will enter a lockout state, and control output (OSSD) and lockout output (SSD) will turn OFF. Also, the fault indicator (yellow) on the receiver will light up or blink.

: Blinks in yellow, : Blinks in orange, : Lights up in red, : Lights up in green, : Turns OFF

Setting procedure and check items		Indicators		Control output (OSSD)	Lockout output (SSD)
		Emitter	Receiver		
Normal state		<input checked="" type="checkbox"/> POWER <input type="checkbox"/> TEST <input type="checkbox"/> FREQ <input type="checkbox"/> FAULT	<input checked="" type="checkbox"/> OSSD <input type="checkbox"/> STB <input type="checkbox"/> FREQ <input type="checkbox"/> FAULT	ON	ON
Error state	Emitter abnormal	<input type="checkbox"/> POWER <input type="checkbox"/> TEST <input type="checkbox"/> FREQ  FAULT	 OSSD  STB <input type="checkbox"/> FREQ  FAULT Blink alternately	OFF	OFF
	Receiver abnormal	<input checked="" type="checkbox"/> POWER <input type="checkbox"/> TEST <input type="checkbox"/> FREQ <input type="checkbox"/> FAULT	<input checked="" type="checkbox"/> OSSD <input type="checkbox"/> STB <input type="checkbox"/> FREQ  FAULT	OFF	OFF

Since this device will not return to normal operation automatically after the removal of the source of error, it is necessary to turn the power OFF and ON again.

(Source of error): The control output (OSSD) short-circuit, extraneous light detection, sensor failure, etc.

“Chapter 5 Troubleshooting” and remove the source of error.

# Chapter 3 Functions

## 3-1 Self-diagnosis Function

This device incorporates the self-diagnosis function.

Self-diagnosis is performed when the power is turned ON or after the status of test input changes from OFF to ON. If an error is detected, the device will immediately enter a lockout state, and control output (OSSD) and lockout output (SSD) will be fixed to OFF.

Eliminate the cause of the error by referring to “Chapter 5 Troubleshooting.”

<b>⚠ WARNING</b>
<ul style="list-style-type: none"> <li>• To maintain safety, inspect the light block state of this device at least once a day.</li> <li>• Failure to perform self-diagnosis will delay the detection of unexpected errors and increase danger, possibly causing this device to malfunction and resulting in serious injury or death.</li> </ul>

## 3-2 Test Input Function

This function enables checking of the device operation by forcibly turning ON / OFF the control output (OSSD) of the receiver with the emitting light is received.

Control output (OSSD) can be turned ON or OFF by connecting or disconnecting the test input wire (pink).

Test input wire (pink)	Test input	Control output (OSSD) status	Lockout output (SSD) status
Open	Invalid	ON	ON
PNP output type: Connect to +V NPN output type: Connect to 0V	Valid	OFF	ON

When the test input is valid, the control output (OSSD) becomes OFF.

By using this function, malfunction due to extraneous noise or abnormality in the control output (OSSD) can be determined even from the equipment side.

Disconnecting the test input wire (pink) returns the device to normal operation mode.

### <Timing chart>

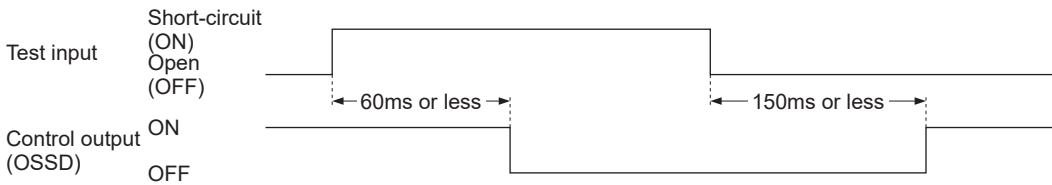

<b>⚠ WARNING</b>
Do not use the auxiliary output for the purpose of stopping the machine in which the <b>SF2C</b> series is installed. Failure to do so could result in death or serious injury.

<p><b>&lt;Reference&gt;</b></p> <p>Enabling test input when using the interference prevention function will cause the control output (OSSD) of all connected sensors to turn OFF.</p>
---

### 3-3 Lockout Function

#### 3-3-1 Lockout Output (SSD)

Lockout output (SSD) turns ON during normal operation and OFF during lockout operation.

<Timing chart>

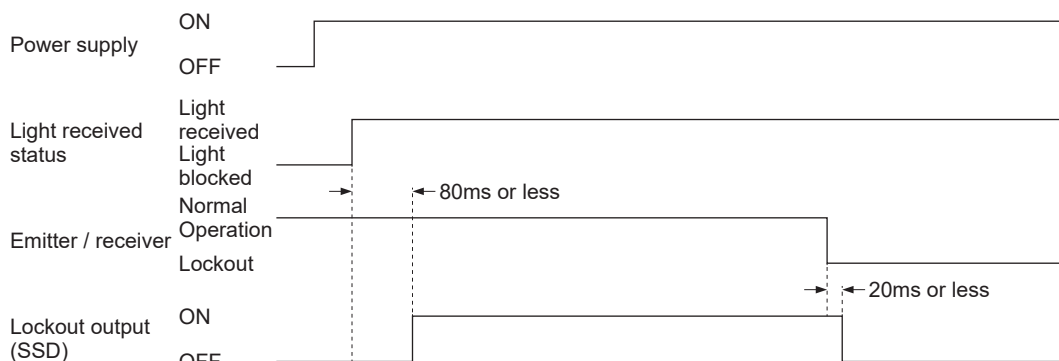

Note: If light from the emitter enters the receiver while the emitter is locked out, lockout information will be communicated to the receiver, causing lockout output (SSD) to turn OFF.

#### 3-3-2 Lockout Release Function

This function returns this device from the lockout status to the normal operation status.

If the test input function (described in “3-2 Test Input Function”) is used when this device is in the status where all the beam channels are receiving light, and any errors have been eliminated from this device, the device will return to its normal operation.

<Reference>

It is also possible to return from the lockout status by turning OFF and then ON the power to this device.

<Timing chart>

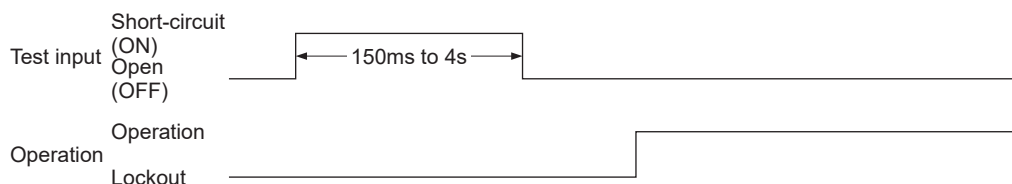

### 3-4 Interference Prevention Function

Connecting the interference prevention output wire (green) for the light curtain 1 emitter with the test input wire (pink) for the light curtain 2 emitter, leaving the frequency setting input wire (gray) for the light curtain 1 receiver open, and connecting the frequency setting input wire (gray) for the light curtain 2 receiver to +V will cause the interference prevention function to be enabled.

Refer to “2-5-4 Wiring for Test Input Function / Large Multi-purpose Indicator Function / Interference Prevention Function” for details of the connecting method.

# Functions

## 3-5 Large Multi-purpose Indicator Function

The selection of lights up / turns OFF is available by wiring the large multi-purpose indicator input wire (orange).

Large multi-purpose indicator input 1 wire (orange)	Operation of the large multi-purpose indicator
PNP output type: Connect to +V NPN output type: Connect to 0V	Lights up in orange
Open	Turns OFF

### <Timing chart>

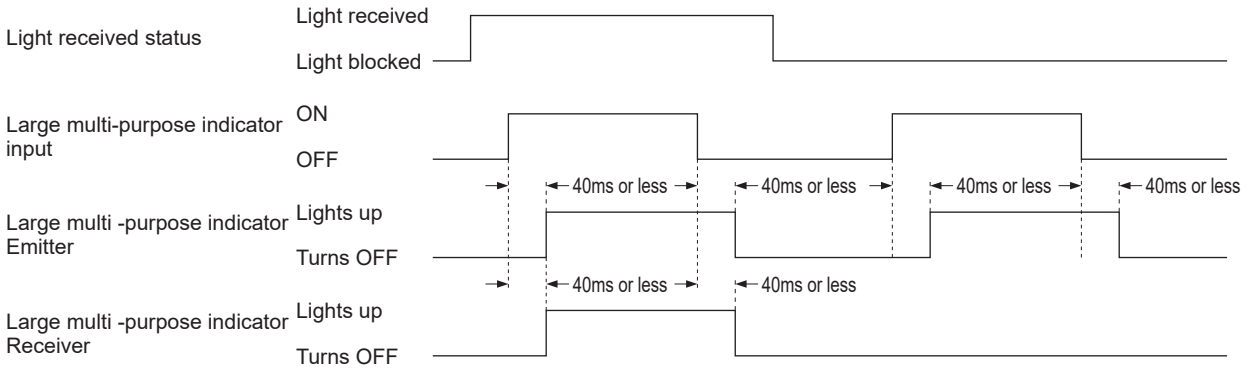

**<Reference>**

When any errors are found, refer to “**Chapter 5 Troubleshooting**” and report the symptoms to the maintenance in charge.  
 If the rectification method is not clear, please contact our office.  
 Please make a copy of this checklist, check each inspection item in the respective square, and file the list for record.

## 4-1 Daily Inspection

**⚠ WARNING**

Be sure to inspect the following items prior to operation and confirm that there is no error. Operating this device without inspection or in an error condition can result in death or serious injury.

**Check list (Daily inspection)**

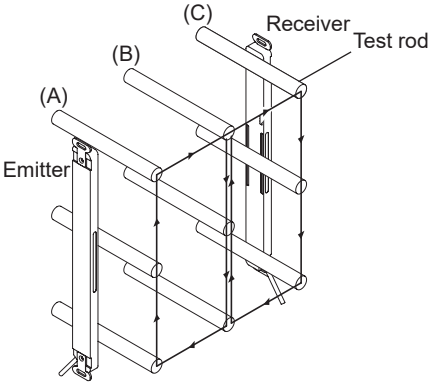
Check column	Inspection item
<input type="checkbox"/>	Dangerous parts of the machine cannot be reached without passing through the sensing area of this device.
<input type="checkbox"/>	Some part of operator's body remains in the sensing area when operation is done with dangerous parts of the machine.
<input type="checkbox"/>	The calculated safety distance has been maintained or exceeded during installation.
<input type="checkbox"/>	There is no damage to the safety guard or protective structure.
<input type="checkbox"/>	There is no defect, fold, or damage in the wiring.
<input type="checkbox"/>	The corresponding connectors have been connected securely.
<input type="checkbox"/>	No dirt or scratches exist on the light emitting surface.
<input type="checkbox"/>	The test rod is not deformed or defective.
<input type="checkbox"/>	The operation indicator (green) of the emitter and the OSSD indicator (green) of the receiver light up when no object is present in the sensing area. The control output (OSSD) shall be ON. At this time, the effect of external noise can be inspected. In case external noise affects the operation, remove its cause and reinspect.
<input type="checkbox"/>	<p>Move the test rod (ø25mm) up and down 1,600 mm/sec. or less at three positions, just in front of the emitter (A), between the emitter and receiver (B) and just in front of the receiver (C).                      The OSSD indicator (red) of the receiver and the operation indicator (red) of the emitter continue to light up as long as the test rod is present in the sensing area from (A) to (C).</p> 
<input type="checkbox"/>	With the machine in the operating condition, the dangerous parts operate normally when no object is present in the sensing area.
<input type="checkbox"/>	With the machine in the operating condition, the dangerous parts stop immediately when the test rod (ø25mm) is inserted into the sensing area at any of the three positions, directly in front of the emitter (A), midway between the emitter and the receiver (B), and directly in front of the receiver (C).
<input type="checkbox"/>	The dangerous parts remain stopped as long as the test rod is present in the sensing area.
<input type="checkbox"/>	The dangerous parts stop immediately when the power supply of this device is turned OFF.
<input type="checkbox"/>	The control output (OSSD) must turn OFF when the test input wire (pink) is open (PNP output type: connected to +V, NPN output type: connected to 0V). At this time, the effect of external noise can be inspected. In case external noise affects the operation, remove its cause and reinspect.

# Maintenance

---

## 4-2 Periodic Inspection (Every Six Months)

 <b>WARNING</b>
Be sure to inspect the following items every six months and confirm that there is no error. Operating this device without inspection or in an error condition can result in death or serious injury.

### Check list (Periodic inspection)

Check column	Inspection item
<input type="checkbox"/>	The structure of the machine does not obstruct any safety mechanism for stopping operation.
<input type="checkbox"/>	No modification has been made in the machine controls which obstructs the safety mechanisms.
<input type="checkbox"/>	The output of this device is correctly detected.
<input type="checkbox"/>	The wiring from this device is correct.
<input type="checkbox"/>	The overall response time of the complete machine is equal or less than the calculated value.
<input type="checkbox"/>	The actual number of operation cycle (time) of the limited lifetime parts (relay, etc.) is less than their rated operation cycles (time).
<input type="checkbox"/>	No screws or connectors of this device are loose.
<input type="checkbox"/>	No extraneous light source or reflective object has been added near this device.

## 4-3 Inspection after Maintenance

Under the following situations, perform all the inspection items mentioned in “4-1 Daily Inspection” and “4-2 Periodic Inspection (Every Six Months).”

- 1) When any parts of this device are replaced.
- 2) When some abnormality is felt during operation.
- 3) When beam-axis alignment of the emitter and receiver is done.
- 4) When the device installation place or environment is changed.
- 5) When the wiring method or wiring layout is changed.
- 6) When FSD (Final Switching Device) parts are replaced.
- 7) When FSD (Final Switching Device) setting is changed.

**<Reference>**

- Check the wiring.
- Check the power supply voltage and the power supply capacity.

### 5-1 Troubleshooting of Emitter

**<All indicators are OFF>**

Cause	Remedy
Power is not being supplied.	Check that the power supply capacity is sufficient. Connect the power supply correctly.
Supply voltage is out of the specified range.	Set the supply voltage correctly.

**<Fault indicator (yellow) lights or blinks>**

After eliminating the cause of the error, either turn OFF and then ON the power or use the lockout release function (as described in “3-3 Lockout Release Function”).

If there are no other errors, this device will operate normally.

Cause	Remedy
Fault indicator (yellow) blinks 8 times Supply voltage error	Specified voltage is not being supplied. Check the wiring status, supply voltage, and power supply capacity.
Other than the above	Effect from noise / power supply or failure of internal circuit Check the noise status around this device. Check the wiring status, supply voltage, and power supply capacity. Even if the error is not cleared, contact Panasonic Industry.

**<Test indicator (red) lights up>**

Cause	Remedy
The device is in the test input condition.	Open the test input input wire (pink).

**<No light is received even though the test indicator (red) lights up>**

Cause	Remedy
Test input wire is abnormal. Test input wire is short-circuited or broken. Test input wire and interference prevention output wire are short-circuited.	Check the wiring of the test input wire (pink), and turn OFF and then ON the power.

If the device does not work correctly after checking the items above, please consult us.

**<Reference>**

About counting blinks of the error indicator, count blinks from 2 seconds of no blinking.

## Troubleshooting

### 5-2 Troubleshooting of Receiver

#### <All indicators are OFF>

Cause	Remedy
Power is not being supplied.	Check that the power supply capacity is sufficient. Connect the power supply correctly.
Supply voltage is out of the specified range.	Set the supply voltage correctly.

#### <Fault indicator (yellow) and unstable light reception indicator (orange) blink alternately>

Cause	Remedy
The emitter is in a lockout state.	Check the fault indicator (yellow) on the emitter.

#### <Fault indicator (yellow) lights or blinks>

After eliminating the cause of the error, either turn OFF and then ON the power or use the lockout release function (as described in “**3-3 Lockout Release Function**”).

If there are no other errors, this device will operate normally.

Cause	Remedy	
Fault indicator (yellow) blinks 2 times Lockout output (SSD) error	Lockout output (SSD) wire (white) is short-circuited. Muting lamp output short-circuits with other I/O wires. Excessive incoming current flows in the lockout output (SSD) wire (white). Output circuit error	Wire the lockout output (SSD) wire (white) correctly. Refer to “ <b>2-5 Wiring.</b> ” Current value should be within the specified lockout output (SSD) wire (white). Refer to “ <b>6-1 Wiring.</b> ”
Fault indicator (yellow) blinks 4 times Extraneous light error	Extraneous light is entering or light from other model is entering.	When the power is ON, prevent any extraneous light from entering the receiver. If the extraneous light is coming from other model, conduct “ <b>2-3-4 Device Placement.</b> ”
Fault indicator (yellow) blinks 5 or 9 times Control output (OSSD) data error	Control output (OSSD) wire (black) is short-circuited. Control output (OSSD) wire (black) or Lockout output (SSD) wire (white) is wired or is wired with other I/O wires. Excessive incoming current flows in the control output (OSSD) wire (black). Output circuit error	Wire the control output (OSSD) wire (black) correctly. Refer to “ <b>2-5 Wiring.</b> ” Current value should be within the specified control output (OSSD) wire (black). Refer to “ <b>6-1 Wiring.</b> ”
Fault indicator (yellow) blinks 8 times Supply voltage error	Specified voltage is not being supplied.	Check the wiring status, supply voltage, and power supply capacity.
Other than the above	Effect from noise / power supply or failure of internal circuit	Check the noise status around this device. Check the wiring status, supply voltage, and power supply capacity. Even if the error is not cleared, contact Panasonic Industry.

#### <Frequency setting indicator (orange) lights up>

Cause	Remedy
Frequency setting input wire is abnormal. Frequency setting input wire and +V are short-circuited.	If the interference prevention function is not used, disconnect the frequency setting input wire (gray). Check the wiring of the frequency setting input wire (gray), and turn OFF and then ON the power.

#### <OSSD indicator remains lit in red (light is not received)>

Cause	Remedy
The beam channels are not correctly aligned.	Align the beam channels. Refer to “ <b>2-6 Adjustment.</b> ” Align the top / bottom direction of the beam channel between emitter and receiver.
The frequency setting is incorrect.	Check the frequency setting indicators (orange) on the emitter and the receiver. Check the wiring of the test input wire (pink) on the emitter and the frequency setting input wire (gray) on the receiver to ensure the correct frequency. Refer to “ <b>2-5-4 Wiring for Test Input Function / Large Multi-purpose Indicator Function / Interference Prevention Function.</b> ” Check the wiring, and turn OFF and then ON the power.

If the device does not work correctly after checking the items above, please consult us.

#### <Reference>

About counting blinks of the error indicator, count blinks from 2 seconds of no blinking.



## 6-1 Specifications

Model No.

SF2C - H     -  

<Output type>

P: PNP output type, N: NPN output type

<Number of beam channels>

Example: **SF2C-H32-P**

Number of beam channels: 32 channels

Output type: PNP output type

### Model-wise specifications

Type		20mm pitch type			
Model No.	PNP output type	SF2C-H8-P	SF2C-H12-P	SF2C-H16-P	SF2C-H20-P
	NPN output type	SF2C-H8-N	SF2C-H12-N	SF2C-H16-N	SF2C-H20-N
Number of beam channels		8	12	16	20
Sensing height (Protective height)		160mm	240mm	320mm	400mm
Current consumption	Large multi-purpose indicator OFF	Emitter: 25mA or less Receiver: 25mA or less	Emitter: 30mA or less, Receiver: 30mA or less		Emitter: 35mA or less Receiver: 35mA or less
	Large multi-purpose indicator ON	Emitter: 35mA or less Receiver: 30mA or less	Emitter: 35mA or less Receiver: 35mA or less	Emitter: 40mA or less Receiver: 35mA or less	Emitter: 40mA or less Receiver: 40mA or less
PFHd	PNP output type	$3.60 \times 10^{-9}$	$3.66 \times 10^{-9}$	$3.73 \times 10^{-9}$	$3.79 \times 10^{-9}$
	NPN output type	$3.74 \times 10^{-9}$	$3.80 \times 10^{-9}$	$3.86 \times 10^{-9}$	$3.93 \times 10^{-9}$
MTTFd		More than 100 years			
Weight (total of emitter and receiver)		Approx. 280g	Approx. 340g	Approx. 400g	Approx. 460g

Type		20mm pitch type		
Model No.	PNP output type	SF2C-H24-P	SF2C-H28-P	SF2C-H32-P
	NPN output type	SF2C-H24-N	SF2C-H28-N	SF2C-H32-N
Number of beam channels		24	28	32
Sensing height (Protective height)		480mm	560mm	640mm
Current consumption	Large multi-purpose indicator OFF	Emitter: 35mA or less, Receiver: 35mA or less		
	Large multi-purpose indicator ON	Emitter: 45mA or less Receiver: 40mA or less	Emitter: 45mA or less Receiver: 45mA or less	Emitter: 50mA or less Receiver: 45mA or less
PFHd	PNP output type	$3.85 \times 10^{-9}$	$3.92 \times 10^{-9}$	$3.98 \times 10^{-9}$
	NPN output type	$3.99 \times 10^{-9}$	$4.05 \times 10^{-9}$	$4.12 \times 10^{-9}$
MTTFd		More than 100 years		
Weight (total of emitter and receiver)		Approx. 520g	Approx. 580g	Approx. 640g

PFHd: Probability of dangerous failure per hour, MTTFd: Mean time to dangerous failure

# Specifications

## Common specifications

Type	PNP output type	NPN output type
Model No.	<b>SF2C-H□-P</b>	<b>SF2C-H□-N</b>
Sensing range (Valid range)	0.1 to 3m	
Beam pitch	20mm	
Detecting capability (Min. sensing object)	ø25mm opaque object	
Effective aperture angle (EAA)	±5 degree or less [for sensing range at 3m (Required by IEC 61496-2, ANSI / UL 61496-2)]	
Supply voltage	24V DC ±20% Ripple P-P 10% or less	
Control output (OSSD)	<ul style="list-style-type: none"> <li>• Maximum source current: 200mA</li> <li>• Applied voltage: same as supply voltage (between the control output and +V)</li> <li>• Residual voltage: 2.5V or less (source current 200mA, when using 10m length cable)</li> <li>• Leakage current: 200µA or less (power supply OFF condition)</li> <li>• Maximum load capacity: 2.2µF (No load to maximum output current)</li> <li>• Load wiring resistance: 3Ω or less</li> </ul>	<ul style="list-style-type: none"> <li>• Maximum sink current: 200mA</li> <li>• Applied voltage: same as supply voltage (between the control output and -0V)</li> <li>• Residual voltage: 2.5V or less (sink current 200mA, when using 10m length cable)</li> <li>• Leakage current: 200µA or less (power supply OFF condition)</li> <li>• Maximum load capacity: 2.2µF (No load to maximum output current)</li> <li>• Load wiring resistance: 3Ω or less</li> </ul>
	Operation mode (Output operation)	ON when all lights are received, OFF when one or more lights are interrupted (OFF when fault occurs in the sensor or the synchronization signal error, too)
Protection circuit (Short-circuit protection)	Incorporated	
Response time	OFF: 20ms or less, ON: 80 to 100ms	
Lockout output (SSD)	<ul style="list-style-type: none"> <li>• Maximum source current: 60mA</li> <li>• Applied voltage: same as supply voltage (between the lockout output and +V)</li> <li>• Residual voltage: 2.5V or less (source current 60mA, when using 10m length cable)</li> <li>• Leakage current: 200µA or less (power supply OFF condition)</li> <li>• Maximum load capacity: 2.2µF (No load to maximum output current)</li> <li>• Load wiring resistance: 3Ω or less</li> </ul>	<ul style="list-style-type: none"> <li>• Maximum sink current: 60mA</li> <li>• Applied voltage: same as supply voltage (between the lockout output and -0V)</li> <li>• Residual voltage: 2.5V or less (sink current 60mA, when using 10m length cable)</li> <li>• Leakage current: 200µA or less (power supply OFF condition)</li> <li>• Maximum load capacity: 2.2µF (No load to maximum output current)</li> <li>• Load wiring resistance: 3Ω or less</li> </ul>
	Operation mode (Output operation)	ON during normal operation, OFF during lockout (Note 1)
Protection circuit (Short-circuit protection)	Incorporated	
Protection	IP65, IP67(IEC)	
Degree of pollution	3	
Ambient temperature	-10 to +55°C (No dew condensation or icing allowed), Storage: -25 to 60°C	
Ambient humidity	30 to 85% RH, Storage: 30 to 85% RH	
Ambient illuminance	Incandescent lamp: 5,000 lx or less at the light-receiving surface	
Operating altitude	2,000m or less (Note 3)	
Voltage withstandability	1,000V AC for one minute between all supply terminals connected together and enclosure	
Insulation resistance	20MΩ or more, with 500V DC megger between all supply terminals connected together and enclosure	
Vibration resistance	10 to 55Hz frequency, 0.75mm amplitude in X, Y, and Z directions for two hours each	
Shock resistance	300m/s <sup>2</sup> acceleration (30G approx.) in X, Y, and Z directions for three times each	
SFF (Safe failure fraction)	99%	
HFT (Hardware failure tolerance)	0	
Sub system type	Type B (IEC 61508-2)	
Mission time	20 years	
Emitting element	Infrared LED (Peak emission wavelength: 850nm)	
Cable	0.16mm <sup>2</sup> 5-core heat-resistant PVC cable, 3m long	
Cable extension	Extension up to total 50m is possible for 0.3mm <sup>2</sup> or more, cable	
Material	Enclosure: Polycarbonate alloy, Sensing surface cover: Polycarbonate <b>MS-SFC-1</b> (Standard mounting bracket): Stainless steel	
Accessories	<b>MS-SFC-1</b> (Standard mounting bracket): 1 set, <b>SF4C-TR25</b> (Test rod): 1 pc.	

Notes: 1) If the emitter enters a lockout state, and light from the emitter enters the receiver, lockout information will be transmitted and lockout output (SSD) will turn OFF.

2) Do not use or storage in environment of more than atmospheric pressure at sea level.

## 6-2 Options

- Standard mounting bracket: 4 pcs./set

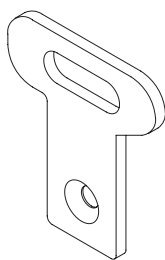

Model No.	Remarks
<b>MS-SFC-1</b>	For two hexagon-socket head bolts [M5 (please arrange separately)].

- NA2-N compatible mounting bracket: 4 pc./set

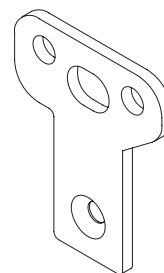

Model No.	Remarks
<b>MS-SFC-2</b>	This mounting bracket is for replacing the other Panasonic Industry area sensor <b>NA2-N</b> series. With two M4 screws (please arrange separately) and one hexagon-socket head bolt [M6 (please arrange separately)].

- Multifunctional mounting bracket: 4 pcs./set

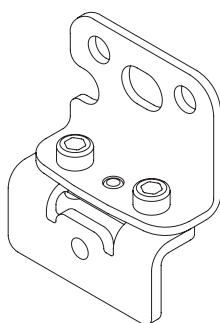

Model No.	Remarks
<b>MS-SFC-3</b>	Can adjust light axis. Can be used as dead space less bracket. For a hexagon-socket head bolts [M5 (please arrange separately)] or two hexagon-socket head bolts [M3 (please arrange separately)].

- Multifunctional intermediate supporting bracket: 2 pcs./set

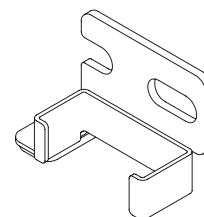

Model No.	Remarks
<b>MS-SFC-4</b>	Prevent spring when using multifunctional mounting bracket <b>MS-SFC-3</b> (optional). When mounting multifunctional bracket <b>MS-SFC-3</b> (optional) to <b>SF2C-H28-□</b> or <b>SF2C-H32-□</b> , you must use.

- Protective metal case: 2 pcs./set



Model No.	Applicable model		Remarks
<b>MS-SFCH-8</b>	<b>SF2C-H8-P</b>	<b>SF2C-H8-N</b>	Protect this device from shocks and vibrations.
<b>MS-SFCH-12</b>	<b>SF2C-H12-P</b>	<b>SF2C-H12-N</b>	
<b>MS-SFCH-16</b>	<b>SF2C-H16-P</b>	<b>SF2C-H16-N</b>	
<b>MS-SFCH-20</b>	<b>SF2C-H20-P</b>	<b>SF2C-H20-N</b>	
<b>MS-SFCH-24</b>	<b>SF2C-H24-P</b>	<b>SF2C-H24-N</b>	
<b>MS-SFCH-28</b>	<b>SF2C-H28-P</b>	<b>SF2C-H28-N</b>	
<b>MS-SFCH-32</b>	<b>SF2C-H32-P</b>	<b>SF2C-H32-N</b>	

# Dimensions

## 6-3 Dimension

### 6-3-1 In Case Mounting on the Center with Standard Mounting Brackets

(Unit: mm)

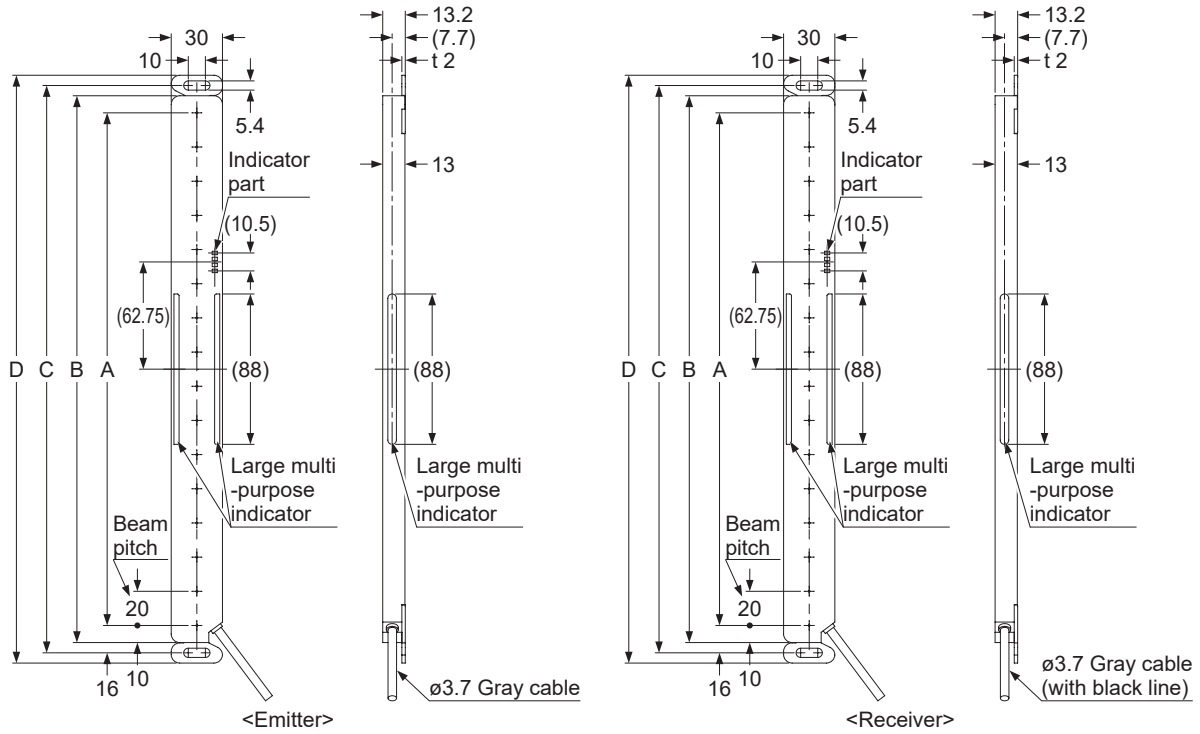

Model No.		A	B	C	D
SF2C-H8-P	SF2C-H8-N	140	160	172	184
SF2C-H12-P	SF2C-H12-N	220	240	252	264
SF2C-H16-P	SF2C-H16-N	300	320	332	344
SF2C-H20-P	SF2C-H20-N	380	400	412	424
SF2C-H24-P	SF2C-H24-N	460	480	492	504
SF2C-H28-P	SF2C-H28-N	540	560	572	584
SF2C-H32-P	SF2C-H32-N	620	640	652	664

6-3-2 In Case Mounting with Standard Mounting Brackets without Dead Space

(Unit: mm)

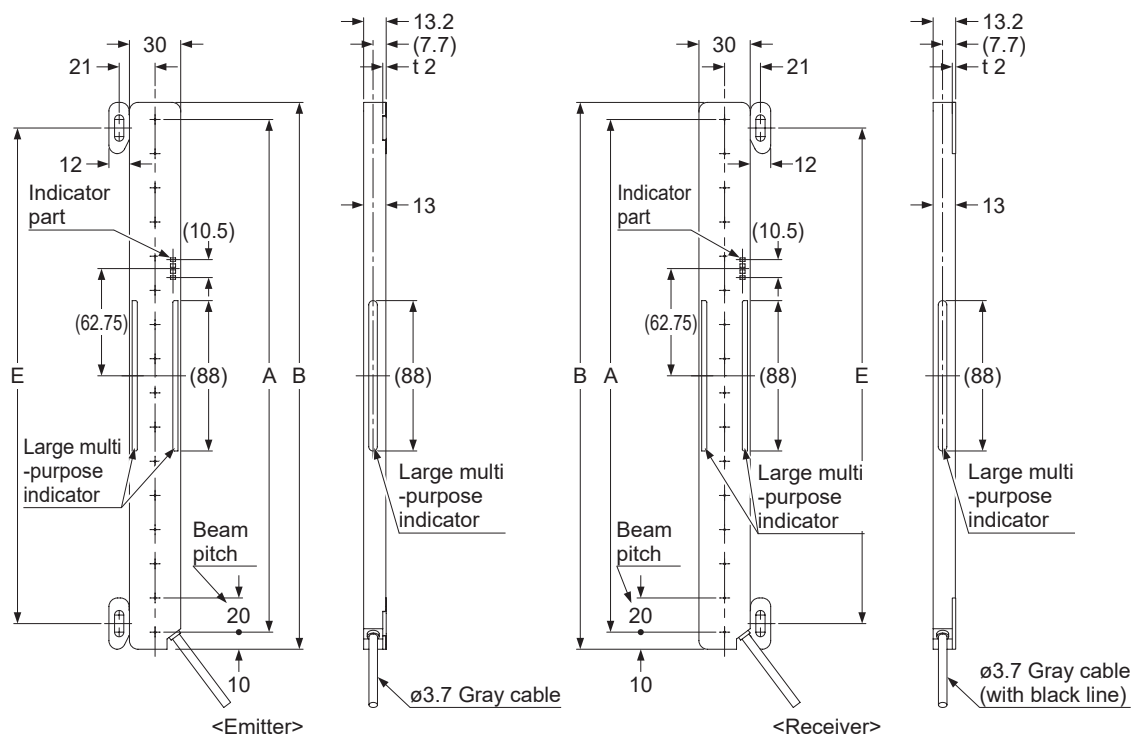

Model No.		A	B	E
SF2C-H8-P	SF2C-H8-N	140	160	130
SF2C-H12-P	SF2C-H12-N	220	240	210
SF2C-H16-P	SF2C-H16-N	300	320	290
SF2C-H20-P	SF2C-H20-N	380	400	370
SF2C-H24-P	SF2C-H24-N	460	480	450
SF2C-H28-P	SF2C-H28-N	540	560	530
SF2C-H32-P	SF2C-H32-N	620	640	610

# Dimensions

## 6-3-3 In Case Mounting with Multifunctional Mounting Bracket

(Unit: mm)

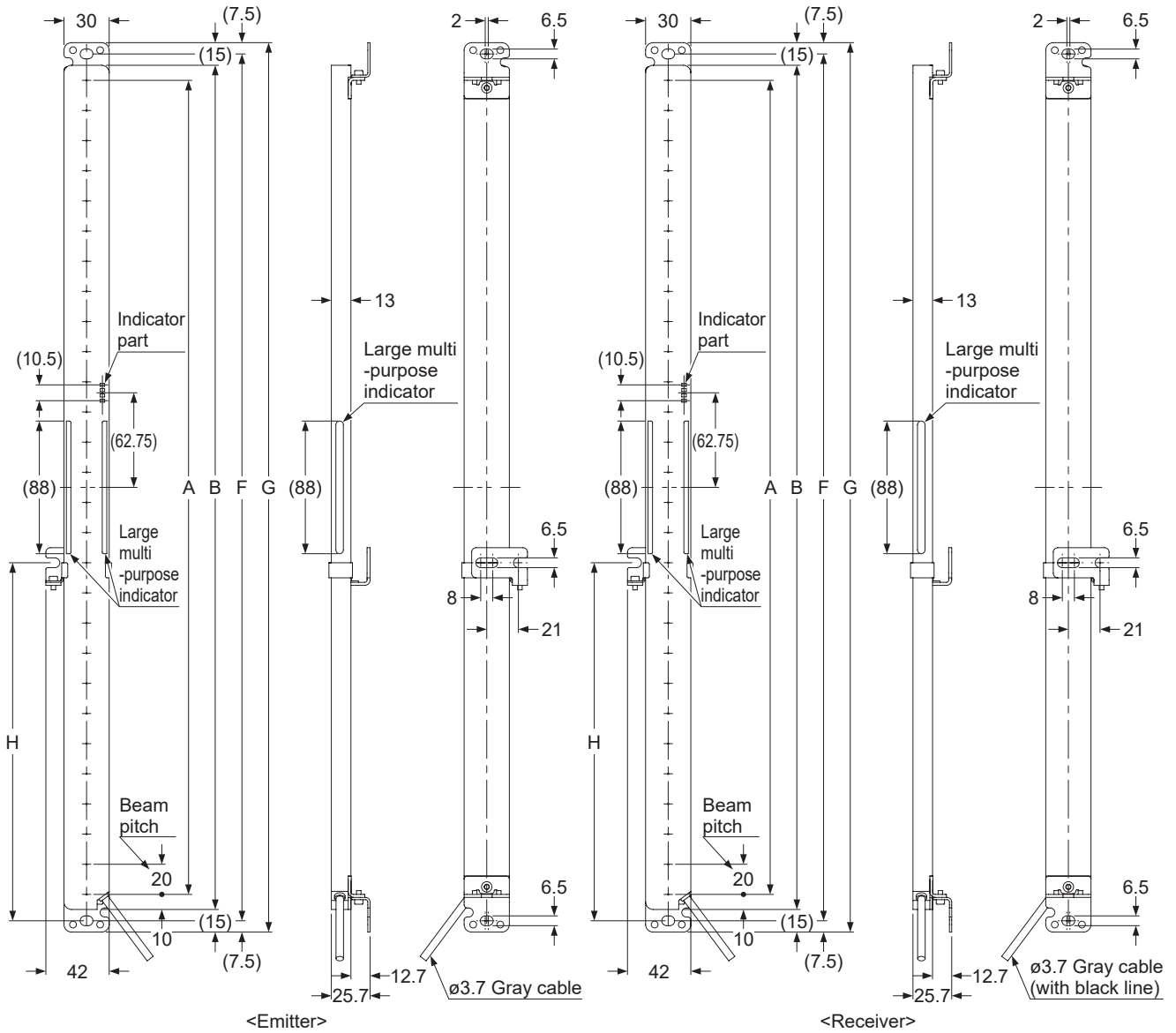

Model No.		A	B	F	G	H
SF2C-H8-P	SF2C-H8-N	140	160	175	190	-
SF2C-H12-P	SF2C-H12-N	220	240	255	270	-
SF2C-H16-P	SF2C-H16-N	300	320	335	350	-
SF2C-H20-P	SF2C-H20-N	380	400	415	430	-
SF2C-H24-P	SF2C-H24-N	460	480	495	510	-
SF2C-H28-P	SF2C-H28-N	540	560	575	590	238 to 338
SF2C-H32-P	SF2C-H32-N	620	640	655	670	278 to 378



# Dimensions

## 6-3-5 In Case Mounting with Protective Metal Case

(Unit: mm)

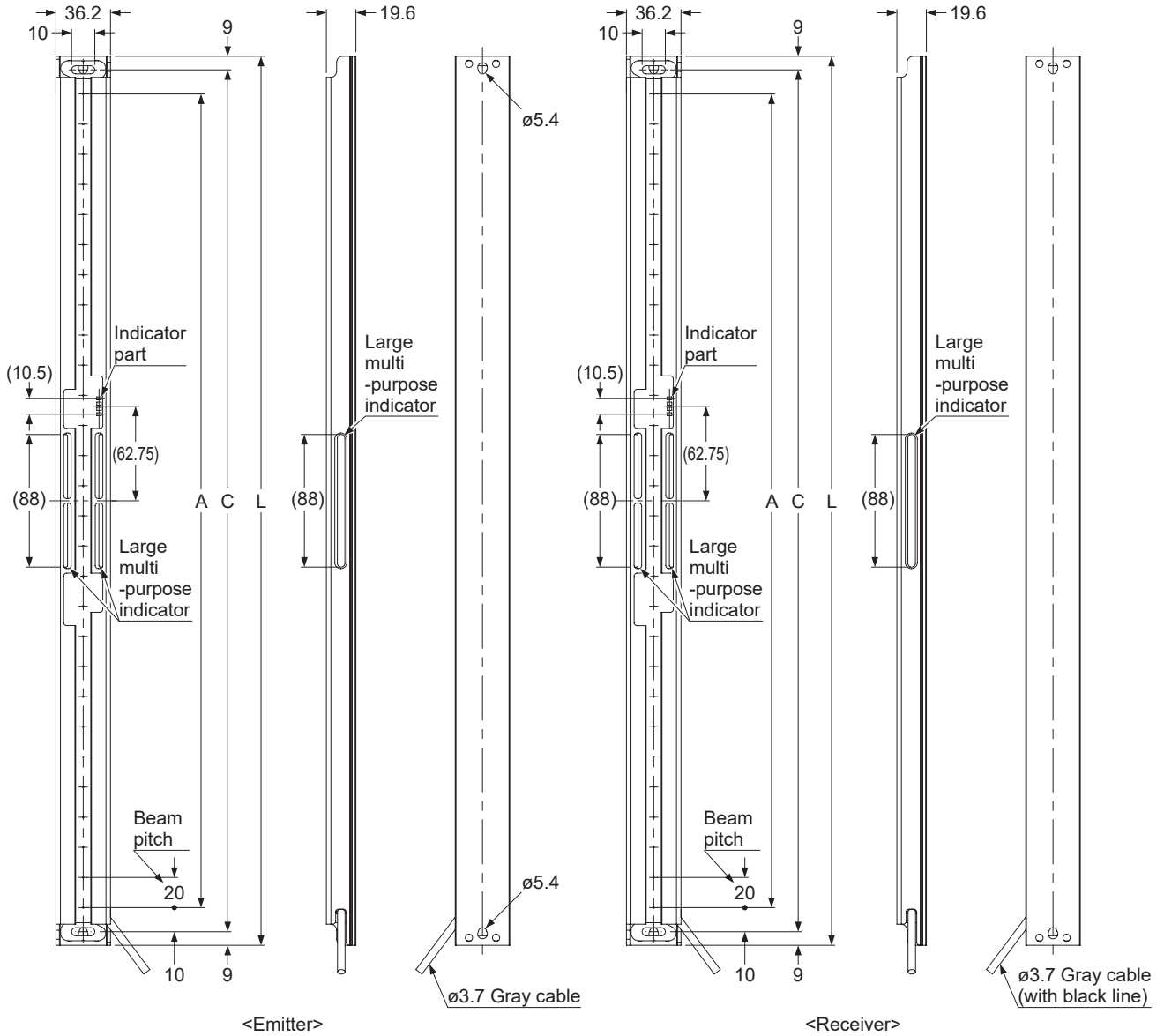

Model No.		A	C	L
SF2C-H8-P	SF2C-H8-N	140	172	190
SF2C-H12-P	SF2C-H12-N	220	252	270
SF2C-H16-P	SF2C-H16-N	300	332	350
SF2C-H20-P	SF2C-H20-N	380	412	430
SF2C-H24-P	SF2C-H24-N	460	492	510
SF2C-H28-P	SF2C-H28-N	540	572	590
SF2C-H32-P	SF2C-H32-N	620	652	670



6-3-6 Mounting Bracket

(Unit: mm)

1) Standard mounting bracket / MS-SFC-1

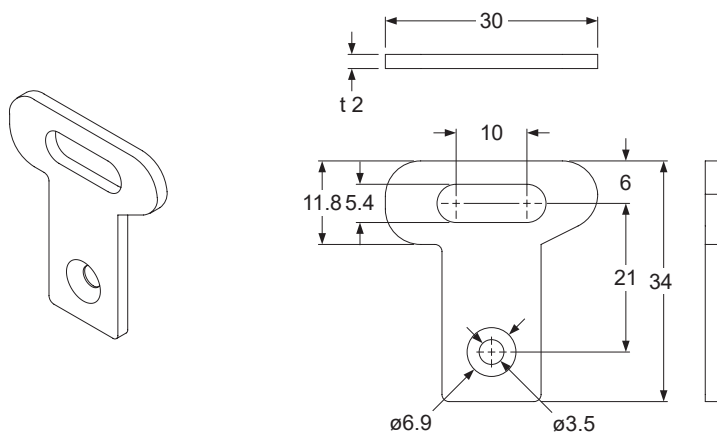

Material: Stainless steel

2) NA2-N compatible mounting bracket / MS-SFC-2

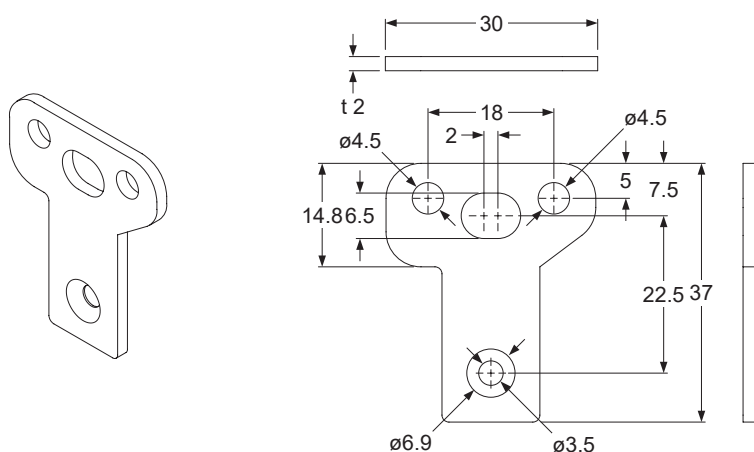

Material: Stainless steel

3) Multifunctional mounting bracket / MS-SFC-3

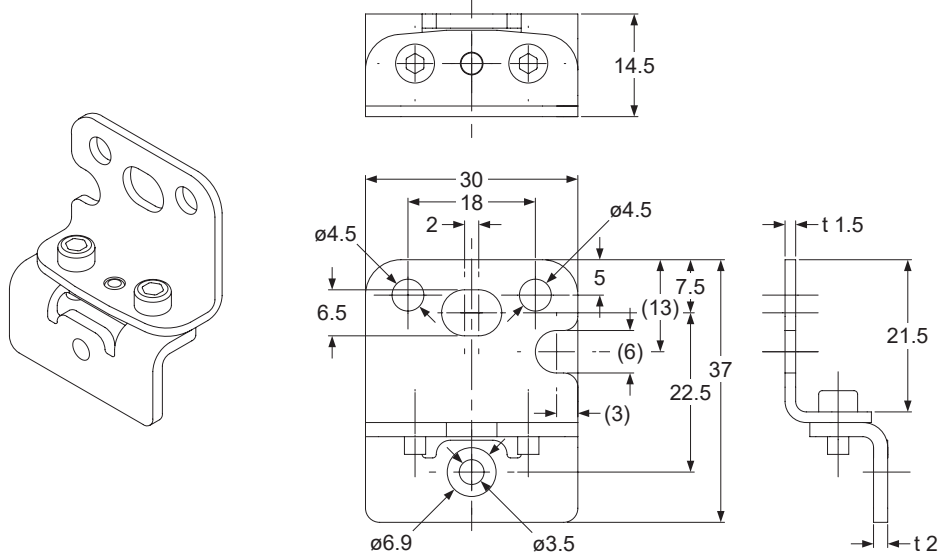

Material: Stainless steel

# Dimensions

## 4) Multifunctional mounting bracket / MS-SFC-3 (in case dead space less mounting)

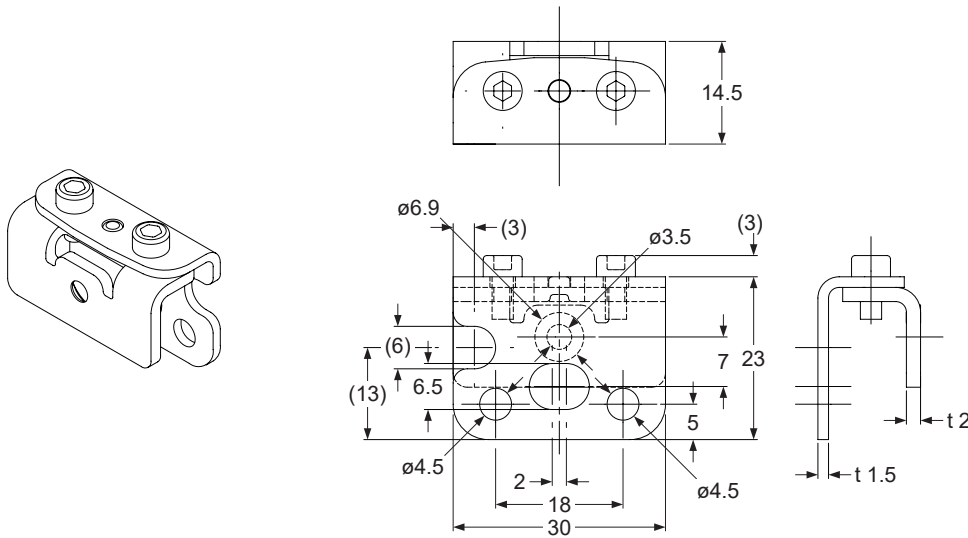

Material: Stainless steel

## 5) Multifunctional intermediate supporting bracket / MS-SFC-4

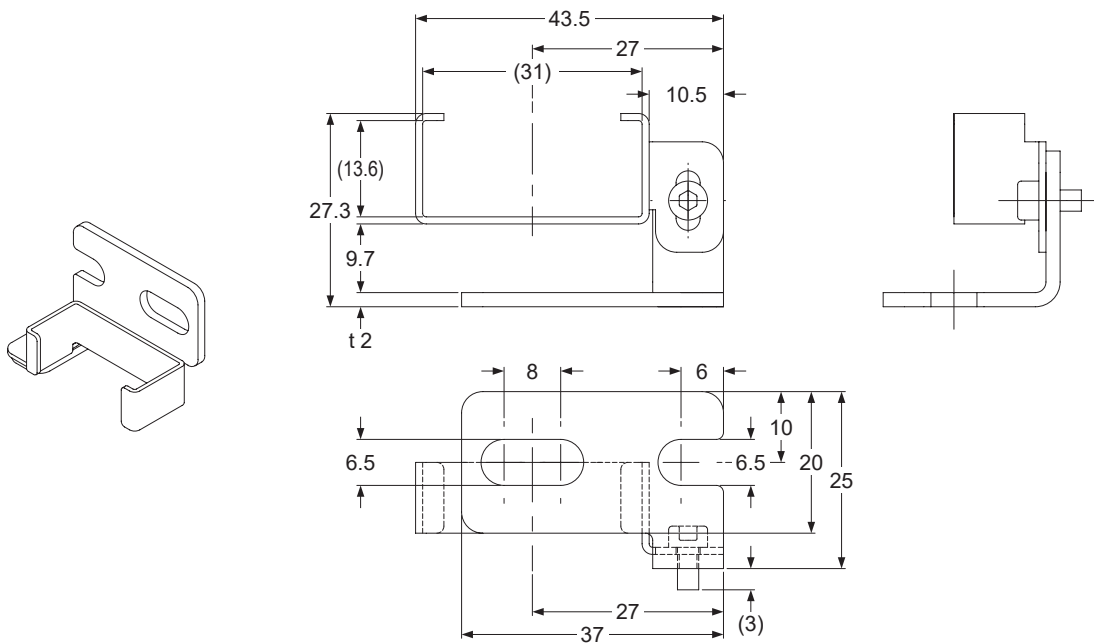

Material: Stainless steel



## Chapter 7 Others

### 7-1 Glossary

Machinery Directive / Machinery Regulations	This directive and regulations is for an assembly of linked parts or components, energized by an electricity, compressed air or oil pressure, etc. and at least one of which moves, and a component which fulfills a safety function and is released into the market by itself.
EMC Directive / EMC Regulations	The directives and regulations is to any electric or electronic devices which will create more than a limited amount of RF interference, or will withstand a certain amount of Electro Magnetic fields while operating as intended within specifications.
EN 61496-1/2 IEC 61496-1/2 ANSI/UL61496-1/2 JIS B 9704-1/2	The standards that pertain to machine safety, especially electro-sensitive protective equipment (ESPE). EN 61496-1, IEC 61496-1, ANSI/UL 61496-1 or JIS B 9704-1 gives general rules or failure mode and effect analysis, EMC requirements, etc. EN 61496-2, IEC 61496-2, ANSI/UL 61496-2 or JIS B 9704-2 specifies effective aperture angle, protection against extraneous light sources, etc, for Active Opto-electronic Protective Devices (AOPDs).
IEC 61508-1 to 7 JIS C 0508-1 to 7	The standards that pertain to electrical / electronic / programmable electronic safety-related systems. They give roles for methods of reducing RISK to be acceptable and safety integrity level (SIL).
EN 55011	Specifies the limits and methods of measurement of radio disturbance characteristics of industrial, scientific and medical (ISM) radio-frequency equipment.
EN ISO 13849-1:2015 ISO 13849-1:2015 JIS B 9705-1	The standard that specifies the safety-related matters of machine safety / control system. They give roles for level (category) of structure and fault detection reliability, and for level of safety future performance capability (PL: Performance Level).
ESPE	The abbreviation for Electro-Sensitive Protective Equipment.
Control output (OSSD)	The abbreviation for Output Signal Switching Device. A component of the light curtain that turns OFF when light of the light curtain is blocked.
Lockout output (SSD)	The abbreviation for Secondary Switching Device. While ESPE is in a lockout state, lockout output responds by turning OFF.
Lockout	One of the safe states of this device. This is the state in which the device has stopped operating when the results of self-diagnosis indicate that the problem is an unrecoverable fault (such as failure to run OSSD normally). If the emitter is in a lockout state, OSSD and SSD for the receiver will turn OFF. If the receiver is in a lockout state, OSSD and SSD will be turned OFF.
FSD	The abbreviation for Final Switching Device. The component of the machine's safety related control system that open-circuits the MPCE circuit when the OSSD operates due to the light from the light curtain being blocked.
Test rod	This is a rod for checking the detection capability of this device. It has dimensions corresponding to the minimum sensing object for this device.
Safety distance	It is the minimum distance that must be maintained between the light curtain and the dangerous parts of a machine so that the machine can be stopped before a human body or an object can reach the dangerous parts.
Sensing height (Protective height)	The length of the beam-axis direction that the min. sensing object can be detected. The length from the center of the first beam channel to the center of the last beam channel in addition to +20mm (+10mm upward, +10mm downward).
Sensing range (Valid range)	It is the range between the facing emitter and receiver.
Sensing area	It is the area over which intrusion by people or objects can be detected by one set of the device. It is given by multiplying the protective height (sensing height) by the sensing range.
Test input function	This function enables checking of the device operation by forcibly turning ON / OFF the control output (OSSD) of the receiver with the emitting light is received.
PSDI	The abbreviation for the Presence Sensing Device Initiation. The safety device that restarts automatically without any operation by the operator after the device detects danger status and halts for a while.

## 7-2 CE Marking Declaration of Conformity

### **Itemized Essentials of EU Declaration of Conformity**

**Manufacturer's Name:** Panasonic Industry Co., Ltd.

**Manufacturer's Address:** 1006, Oaza Kadoma, Kadoma-shi, Osaka 571-8506, Japan

**Product Name:** Active Opto-electronic Protective Device (Light Curtain)

**Model Number:** SF2C Series

**Trade Name:** Panasonic

**Application of Council Directives:**

- 2006/42/EC Machinery
- 2014/30/EU EMC
- 2011/65/EU RoHS

**Applicable Standards:**

- |                        |               |
|------------------------|---------------|
| - EN ISO 13849-1: 2015 | - IEC 61496-1 |
| - EN 55011             | - IEC 61496-2 |
| - EN 61000-6-2         | - IEC 61508-1 |
| - EN IEC 63000         | - IEC 61508-2 |
|                        | - IEC 61508-3 |

**Authorised Representative:**

Panasonic Marketing Europe GmbH, Panasonic Testing Centre  
Winsbergring 15, 22525 Hamburg, Germany

### 7-3 UKCA Marking Declaration of Conformity

#### **Itemized Essentials of UK Declaration of Conformity**

**Manufacturer's Name:** Panasonic Industry Co., Ltd.

**Manufacturer's Address:** 1006, Oaza Kadoma, Kadoma-shi, Osaka 571-8506, Japan

**Product Name:** Active Opto-electronic Protective Device (Light Curtain)

**Trade Name:** Panasonic

**Model Number:** SF2C Series

**Statutory Instruments:**

- 2008/1597 Machinery
- 2016/1091 EMC
- 2012/3032 RoHS

**Designated Standards:**

- |                        |               |
|------------------------|---------------|
| - EN ISO 13849-1: 2015 | - IEC 61496-1 |
| - EN 55011             | - IEC 61496-2 |
| - EN 61000-6-2         | - IEC 61508-1 |
| - EN IEC 63000         | - IEC 61508-2 |
|                        | - IEC 61508-3 |

Panasonic UK, a branch of Panasonic Marketing Europe GmbH  
Maxis 2, Western Road, Bracknell, Berkshire, RG12 1RT

Revision history	Revision date	Revision item
1st edition	February , 2013	—
2nd edition	June , 2013	—
3rd edition	September , 2013	—
4th edition	May , 2014	—
5th edition	October , 2015	—
6th edition	January , 2016	—
7th edition	March , 2021	<ul style="list-style-type: none"> <li>• Added notes.</li> <li>• Corrected errors.</li> </ul>
8th edition	October , 2021	<ul style="list-style-type: none"> <li>• Changed the Standards.</li> </ul>
9th edition	June , 2023	<ul style="list-style-type: none"> <li>• Revision to reflect change of standards.</li> <li>• Added notes.</li> </ul>
10th edition	April , 2024	<ul style="list-style-type: none"> <li>• Company name change.</li> </ul>

## **1. WARRANTIES:**

- (1) Subject to the exclusions stated in 2 (EXCLUSIONS) herein below, Panasonic Industry warrants the Products to be free of defects in material and workmanship for a period of one (1) year from the date of shipment under normal usage in environments commonly found in manufacturing industry.
- (2) Any Products found to be defective must be shipped to Panasonic Industry with all shipping costs paid by Purchaser or offered to Panasonic Industry for inspection and examination. Upon examination by Panasonic Industry, Panasonic Industry will, at its sole discretion, repair or replace at no charge, or refund the purchase price of, any Products found to be defective.

## **2. EXCLUSIONS:**

- (1) This warranty does not apply to defects resulting from any cause:
  - (i) which was due to abuse, misuse, mishandling, improper installation, improper interfacing, or improper repair by Purchaser;
  - (ii) which was due to unauthorized modification by Purchaser, in part or in whole, whether in structure, performance or specification;
  - (iii) which was not discoverable by a person with the state-of-the-art scientific and technical knowledge at the time of manufacture;
  - (iv) which was due to an operation or use by Purchaser outside of the limits of operation or environment specified by Panasonic Industry;
  - (v) which was due to normal wear and tear;
  - (vi) which was due to Force Majeure; and
  - (vii) which was due to any use or application expressly discouraged by Panasonic Industry in 4 (CAUTIONS FOR SAFE USE) hereunder.
- (2) This warranty extends only to the first purchaser for application, and is not transferable to any person or entity which purchased from such purchaser for application.

## **3. DISCLAIMERS**

- (1) Panasonic Industry's sole obligation and liability under this warranty is limited to the repair or replacement, or refund of the purchase price, of a defective Product, at Panasonic Industry's option.
- (2) THE REPAIR, REPLACEMENT, OR REFUND IS THE EXCLUSIVE REMEDY OF THE PURCHASER, AND ALL OTHER WARRANTIES, EXPRESS OR IMPLIED, INCLUDING, WITHOUT LIMITATION, THE WARRANTIES OF MERCHANTABILITY, FITNESS FOR A PARTICULAR PURPOSE, AND NON-INFRINGEMENT OF PROPRIETARY RIGHTS, ARE HEREBY EXPRESSLY DISCLAIMED. IN NO EVENT SHALL PANASONIC INDUSTRY AND ITS AFFILIATED ENTITIES BE LIABLE FOR DAMAGES IN EXCESS OF THE PURCHASE PRICE OF THE PRODUCTS, OR FOR ANY INDIRECT, INCIDENTAL, SPECIAL OR CONSEQUENTIAL DAMAGES OF ANY KIND, GENERAL TERMS AND CONDITIONS 4 OR ANY DAMAGES RESULTING FROM LOSS OF USE, BUSINESS INTERRUPTION, LOSS OF INFORMATION, LOSS OR INACCURACY OF DATA, LOSS OF PROFITS, LOSS OF SAVINGS, THE COST OF PROCUREMENT OF SUBSTITUTED GOODS, SERVICES OR TECHNOLOGIES, OR FOR ANY MATTER ARISING OUT OF OR IN CONNECTION WITH THE USE OR INABILITY TO USE THE PRODUCTS.

## **4. CAUTIONS FOR SAFE USE**

- (1) The applications shown in the catalogue are only suggestions, and it is Purchaser's sole responsibility to ascertain the fitness and suitability of the Products for any particular application, as well as to abide by Purchaser's applicable local laws and regulations, if any.
- (2) Never use the Products NOT rated or designated as "SAFETY SENSOR" in any application involving risk to life or property. When such a use is made by Purchaser, such Purchaser shall indemnify and hold harmless Panasonic Industry from any liability or damage whatsoever arising out of or in relation to such use.
- (3) In incorporating the Products to any equipment, facilities or systems, it is highly recommended to employ fail-safe designs, including but not limited to a redundant +++design, flame propagation prevention design, and malfunction prevention design so as not to cause any risk of bodily injury, fire accident, or social damage due to any failure of such equipment, facilities or systems.
- (4) The Products are each intended for use only in environments commonly found in manufacturing industry, and, unless expressly allowed in the catalogue, specification or otherwise, shall not be used in, or incorporated into, any equipment, facilities or systems, such as those:
  - (a) which are used for the protection of human life or body parts;
  - (b) which are used outdoors or in environments subject to any likelihood of chemical contamination or electromagnetic influence;
  - (c) which are likely to be used beyond the limits of operations or environments specified by Panasonic Industry in the catalogue or otherwise;
  - (d) which may cause risk to life or property, such as nuclear energy control equipment, transportation equipment (whether on rail or land, or in air or at sea), and medical equipment;
  - (e) which are operated continuously each day for 24 hours; and
  - (f) which otherwise require a high level of safety performance similar to that required in those equipment, facilities or systems as listed in (a) through (e) above.

## **5. EXPORT CONTROL LAWS**

In some jurisdictions, the Products may be subject to local export laws and regulations. If any diversion or re-export is to be made, Purchaser is advised to abide by such local export laws and regulations, if any, at its own responsibility.



(MEMO)

---

## Panasonic Industry Co., Ltd.

1006, Oaza Kadoma, Kadoma-shi, Osaka 571-8506, Japan  
<https://industry.panasonic.com/>

Please visit our website for inquiries and about our sales network.

© Panasonic Industry Co., Ltd. 2013-2024

April, 2024

WUME-SF2C-10