

CC-Link Communication Unit for
Digital Displacement Sensors

SC-HG1-C

User's Manual

(MEMO)

INTRODUCTION

Thank you for purchasing a CC-Link communication unit **SC-HG1-C**.
Before using this product, read and understand this User's Manual. Use the product correctly and in the optimum manner.
Keep this manual in a safe location for reference whenever necessary.

Types of Manuals

The following user's manuals are available for the **SC-HG1-C** series. Refer to the appropriate manual according to your need.
The user's manuals are also available for download from our website (<https://industry.panasonic.com/>).

Unit name or purpose of use	Manual name	Manual code
CC-Link communication unit for digital displacement sensors	SC-HG1-C User's Manual	WUME-SCHG1C
Contact-type digital displacement sensor HG-S series	HG-S User's Manual	WUME-HGS
Thru-beam type digital displacement sensor HG-T series	HG-T User's Manual	WUME-HGT

Please note

- 1) Unauthorized reproduction of part or all of this manual is prohibited.
- 2) The contents of this manual are subject to change without notice.
- 3) This manual has undergone strict quality control procedures; however, in the event that you discover any problems or points of concern, please contact your local dealer.
- 4) CC-Link is a registered trademark of Mitsubishi Electric Corporation and is a trademark managed by CC-Link Partner Association.

Structure of this manual

1 Before Using This Product	Cautions for safe use of the product, terminology, contents of the package, and names and functions of the parts of the product.
2 System Configuration	Types of controllers that can be connected to the product and restrictions.
3 Installation and Connections	Mounting, connecting controllers, connecting external devices, and configuring communication settings.
4 CC-LINK Network Communication	Communication methods.
5 Specifications	Specifications and dimensions.
6 Warranty	Warranty information.
7 Maintenance	Maintenance and inspection.
8 Troubleshooting	Troubleshooting and error codes.

Frequently asked questions

Question	Section	Page
I want to learn about communication commands	4-10 Commands	4-34 page
I want to set threshold values	4-10-3 Command sending procedure	4-50 page
I want to acquire controller output	4-6 Judgment output reading	4-30 page
I want to acquire measured values from a controller	4-8 Continuous reading of measurement data	4-31 page
I want to learn the data acquisition time	4-13 Communication response speed	4-67 page

Contents

INTRODUCTION	3
Types of Manuals	3
Structure of this manual	4
Frequently asked questions	5
1 Before Using This Product	1-1
1-1 Safety rules	1-2
1-2 Safety information	1-3
1-3 Glossary	1-5
1-4 Contents of package	1-6
1-5 Description of parts	1-7
2 System Configuration	2-1
2-1 Communication unit system	2-2
2-2 Unit types	2-4
3 Installation and Connections	3-1
3-1 Steps prior to operation	3-2
3-2 Settings	3-3
3-2-1 CC-Link communication settings	3-3
3-2-2 Communication unit settings	3-4
3-3 Installation	3-6
3-3-1 Mounting	3-6
3-3-2 Connection	3-7
3-3-3 Pin layout	3-9
3-3-4 Host communication cable connection	3-9
3-3-5 Procedure for connecting the CC-Link connector	3-10
3-3-6 Attachment and removal of termination resistor	3-12
4 CC-LINK Network Communication	4-1
4-1 Overview of communication	4-2
4-1-1 Communication with master station	4-2
4-1-2 SC-HG1-C and controller communication	4-3
4-2 Explanation of modes	4-4
4-3 Memory map	4-5
4-3-1 CC-Link mode 1	4-5
4-3-2 CC-Link mode 2	4-14
4-3-3 CC-Link mode 3	4-21
4-4 Memory map and controller assignments	4-28
4-5 Initial operation after power is turned ON	4-29
4-6 Judgment output reading	4-30
4-7 External input	4-30
4-8 Continuous reading of measurement data	4-31
4-9 Error mode	4-33
4-10 Commands	4-34
4-10-1 HG-S series command list	4-34
4-10-2 HG-T series command list	4-39
4-10-3 Command sending procedure	4-50

4 -11 Reading received light waveforms (For the HG-T only)	4-54
4-11-1 Format of received light waveform	4-54
4-11-2 Reading measured waveforms	4-56
4-11-3 Reading reference waveforms	4-59
4-12 Registering the reference waveform (For the HG-T only)	4-62
4-13 Communication response speed	4-67
4-14 Self-monitoring Function	4-68
4-14-1 Using the Self-monitoring Function	4-68
4-14-2 Statuses and Measures	4-69
4-15 Other precautions	4-71
5 Specifications	5-1
5-1 Specifications	5-2
5-2 Dimensions	5-3
6 Warranty	6-1
6-1 When you purchase and use the product	6-2
7 Maintenance	7-1
7-1 Maintenance and Inspection	7-2
7-1-1 Maintenance cautions	7-2
7-1-2 Main inspection items	7-2
8 Troubleshooting	8-1
8-1 Command error	8-2
8-2 Communication errors	8-5
8-3 Description of indicators	8-6
8-4 What to do when a problem occurs	8-7

(MEMO)

1 Before Using This Product

1-1 Safety rules	1-2
1-2 Safety information	1-3
1-3 Glossary	1-5
1-4 Contents of package	1-6
1-5 Description of parts	1-7

Before Using This Product

1-1 Safety rules Always observe

This section explains important rules that must be observed to prevent human injury and property damage.

- The hazards that may occur if the product is used incorrectly are described and classified by level of harm.

 WARNING Risk of death or serious injury.

 CAUTION Risk of minor injury or property damage.

- The following symbols are used to indicate safety information that must be observed.

 Indicates an action that is prohibited.

 Indicates an action that must be taken.

 Indicates a matter that requires caution.

<Reference> Indicates supplemental information.

1-2 Safety information

WARNING

- Never use this product as a sensing device for personnel protection.
- When using sensing devices for personnel protection, use products that meet the laws and standards for personnel protection that apply in each region or country, such as OSHA, ANSI and IEC.

Specifications

- This product has been developed / produced for industrial use only.
- Do not use this product under conditions outside the specified ranges. Risk of an accident and product damage. There is also a risk of a significant reduction of service life.

Power supply

- Incorrect wiring will damage the internal circuitry. Check the wiring before turning ON the power.
- Verify that power supply fluctuations are within the rating.
- Risk of damage and burning if a voltage over the rating is applied, or AC power is directly applied.
- If power is supplied from a commercial switching regulator, ensure that the frame ground (F.G.) terminal is connected to an actual ground.
- Ensure that there is sufficient leeway in the voltage source capacity.
- Do not use during the initial transient time after the power supply is switched ON
For details, refer to “**4-5 Initial operation after power is turned ON**”.
- Use an isolation transformer in the DC power supply. Risk of short-circuiting and damage to the product or power supply if an auto transformer is used.
- If surges occur in the power supply, connect a surge absorber to the source to absorb the surges.

Wiring

- Make sure that the power is OFF while performing wiring or connection work. Risk of electric shock or product damage.
- Risk of damage and burning if the load is incorrectly wired or short-circuiting occurs.
- When noise generating equipment (switching regulator, inverter motor, etc.) is used in the vicinity of this product, connect the frame ground (F.G.) terminal of the equipment separately to ground.
- To avoid noise, keep the wiring as short as possible.
- Do not wire in parallel with a high-voltage line or power line, or run through the same conduit. Risk of malfunctioning due to induction.
- For the communication cable, use a dedicated cable that is certified by CC-Link Partner Association.
- For detailed grounding specifications, refer to the installation manual published by the CC-Link Partner Association.

Usage environment

- This product is suitable for indoor use only.
- Avoid dust, dirt, and steam.
- Do not use in locations where there are corrosive or other harmful gases.
- Ensure that the product does not come into contact with organic solvents such as thinner.
- Ensure that the product does not come into contact with strong acid or alkaline.
- Ensure that the product does not come into contact with oil or grease.
- This product cannot be used in an environment that contains flammable or explosive gases.
- Performance may not be satisfactory in a strong electromagnetic field.
- Do not drop or otherwise subject to shock. Risk of product damage.

Before Using This Product

Other matters

- Never attempt to disassemble, repair, or modify the product.
- When the product becomes unusable or unneeded, dispose of the product appropriately as industrial waste.
- Design the system so that system trouble protection and safety circuits are located externally.
- If your product, which incorporates our product, requires compliance with the EMC Directive / EMC Regulations, install our product in a conductive box in accordance with the "PLC User's Manual" (published by Mitsubishi Electric Corporation).

1-3 Glossary

	Term	Meaning
System terms	Transient transmission	A function in Data Link for communication with other stations using peripheral devices, including reading or writing data from / to another station by means of a read / write command in the program of the local station.
	Cyclic transmission	A function in Data Link for periodic data communication between stations on the same network.
	Memory map	This assigns functions of a communication unit to a link device. By accessing a link device that supports memory map, the master station can use the functions of a communication unit.
	Station number	This number is assigned to identify each network unit connected to a network. The same number cannot be assigned to more than one network unit in a network.
	RX[*]	Remote input Information input from a slave station to the master station in units of bits. [*]: Indicates the bit number in hex.
	RY[*]	Remote output Information output from the master station to a slave station in units of bits. [*]: Indicates the bit number in hex.
	RWw[*]	Remote register (output) Information output from the master station to a slave station in units of words (16 bits). [*]: Indicates the word number in hex.
	RWr[*]	Remote register (input) Information input from a slave station to the master station in units of words (16 bits). [*]: Indicates the word number in hex.
Unit name	Master station	This station controls the overall network. The master station can communicate with all stations by cyclic transmission and transient transmission.
	Slave station	A general name for stations other than the master station (local station, remote I/O station, remote device station, intelligent device station).
	Remote I/O station	Exchanges input / output signals in units of bits with the master station by cyclic transmission.
	Remote device station	Sends information in units of bits and information in units of words by cyclic transmission. Returns a response to a transient transmission from another station.
	Intelligent device station	Sends input / output signals in units of bits and input / output data in units of words to the master station by cyclic transmission. Returns a response to a transient transmission (request) from another station.
	Local station	Communicates with the master station and other local stations by cyclic transmission and transient transmission.
	Controller - Master unit	A controller equipped with power supply, external I/O, and analog current output wires, and which can be used on a standalone basis.
	Controller - Slave unit	A controller that is connected to a master unit.
	CC-Link dedicated cable	Cable certified by CC-Link Partner Association (shielded 3-conductor twisted-pair cable).
	End plates or commercially available fittings	When the product is connected to a controller, the end plates secure the units at both ends to prevent the connector from disconnecting and causing a communication failure.

Before Using This Product

1-4 Contents of package

The following accessories are included in the product package. Before using the product, make sure that no items are missing.

- Communication unit: 1 pc.
- Instruction manual
- General Information for Safety, Compliance, and Instructions

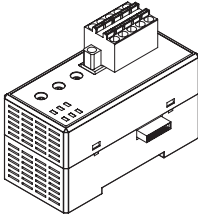

1-5 Description of parts

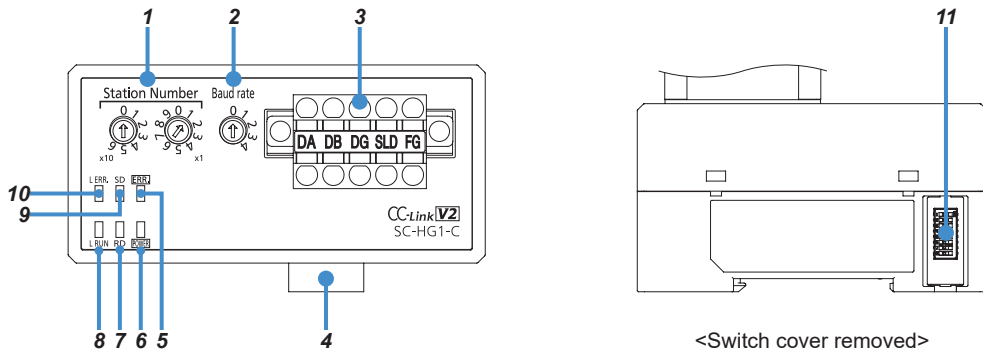

	Name	Function																																																																																	
1	Station number setting switch	Set the CC-Link station number to a value from 1 to 64. (Do not set to 0, or 65 or higher.) [Factory default state: 1]																																																																																	
2	Communication speed setting switch	Set the CC-Link communication speed. 0: 156 kbps, 1: 625 kbps, 2: 2.5 Mbps, 3: 5 Mbps, 4: 10 Mbps [Factory default state: 156 kbps]																																																																																	
3	CC-Link connector	Connect to the master station or another slave station.																																																																																	
4	Male connector	Connect to a master controller or slave controller.																																																																																	
5	ERR. indicator (Red)	Lights up when CC-Link communication is interrupted. Blinks when a communication error occurs.																																																																																	
6	Power indicator (Green)	Lights up when power is supplied.																																																																																	
7	RD indicator (Green)	Lights up during data reception.																																																																																	
8	L RUN indicator (Green)	Lights up during data link execution.																																																																																	
9	SD indicator (Green)	Lights up during data sending.																																																																																	
10	L ERR. indicator (Red)	Lights up if the station number setting switch and communication speed setting switch are in an invalid setting position when the power is turned on. Blinks if the switch type setting is changed while the power is on.																																																																																	
11	Mode setting switch	<p>Set the communication method and number of occupied stations. [Factory default state: CC-Link mode 1]</p> <ul style="list-style-type: none"> • CC-Link mode 1 <table border="1"> <thead> <tr> <th>SW No.</th> <th>1</th> <th>2</th> <th>3</th> <th>4</th> <th>5</th> <th>6</th> <th>7</th> <th>8</th> </tr> </thead> <tbody> <tr> <td>ON / OFF</td> <td>ON</td> <td>OFF</td> <td colspan="6">Not used (Note)</td> </tr> <tr> <td>Remarks</td> <td colspan="8">CC-Link Ver. 1.10, number of occupied stations: 4</td> </tr> </tbody> </table> • CC-Link mode 2 <table border="1"> <thead> <tr> <th>SW No.</th> <th>1</th> <th>2</th> <th>3</th> <th>4</th> <th>5</th> <th>6</th> <th>7</th> <th>8</th> </tr> </thead> <tbody> <tr> <td>ON / OFF</td> <td>OFF</td> <td>ON</td> <td colspan="6">Not used (Note)</td> </tr> <tr> <td>Remarks</td> <td colspan="8">CC-Link Ver.2.00, Number of occupied stations: 2 stations Expanded cyclic transmission speed: x8</td> </tr> </tbody> </table> • CC-Link mode 3 <table border="1"> <thead> <tr> <th>SW No.</th> <th>1</th> <th>2</th> <th>3</th> <th>4</th> <th>5</th> <th>6</th> <th>7</th> <th>8</th> </tr> </thead> <tbody> <tr> <td>ON / OFF</td> <td>ON</td> <td>ON</td> <td colspan="6">Not used (Note)</td> </tr> <tr> <td>Remarks</td> <td colspan="8">CC-Link Ver.2.00, Number of occupied stations: 4 stations Expanded cyclic transmission speed: x4</td> </tr> </tbody> </table> 	SW No.	1	2	3	4	5	6	7	8	ON / OFF	ON	OFF	Not used (Note)						Remarks	CC-Link Ver. 1.10, number of occupied stations: 4								SW No.	1	2	3	4	5	6	7	8	ON / OFF	OFF	ON	Not used (Note)						Remarks	CC-Link Ver.2.00, Number of occupied stations: 2 stations Expanded cyclic transmission speed: x8								SW No.	1	2	3	4	5	6	7	8	ON / OFF	ON	ON	Not used (Note)						Remarks	CC-Link Ver.2.00, Number of occupied stations: 4 stations Expanded cyclic transmission speed: x4							
SW No.	1	2	3	4	5	6	7	8																																																																											
ON / OFF	ON	OFF	Not used (Note)																																																																																
Remarks	CC-Link Ver. 1.10, number of occupied stations: 4																																																																																		
SW No.	1	2	3	4	5	6	7	8																																																																											
ON / OFF	OFF	ON	Not used (Note)																																																																																
Remarks	CC-Link Ver.2.00, Number of occupied stations: 2 stations Expanded cyclic transmission speed: x8																																																																																		
SW No.	1	2	3	4	5	6	7	8																																																																											
ON / OFF	ON	ON	Not used (Note)																																																																																
Remarks	CC-Link Ver.2.00, Number of occupied stations: 4 stations Expanded cyclic transmission speed: x4																																																																																		

Note: Always keep unused switches in the OFF position.

(MEMO)

2 System Configuration

2-1 Communication unit system	2-2
2-2 Unit types	2-4

2-1 Communication unit system

This product is a communication unit for the purpose of monitoring sensor ON / OFF output and detected quantities using CC-Link communication between controllers and a master station.

This product can connect a maximum of 15 controllers (one master controller, 14 slave controllers). The CC-Link operation mode can be set to Ver. 1.10 or Ver. 2.00 (2 stations x8 / 4 stations x4) using the mode setting switch.

The power that drives this product is supplied from a connected controller / master controller.

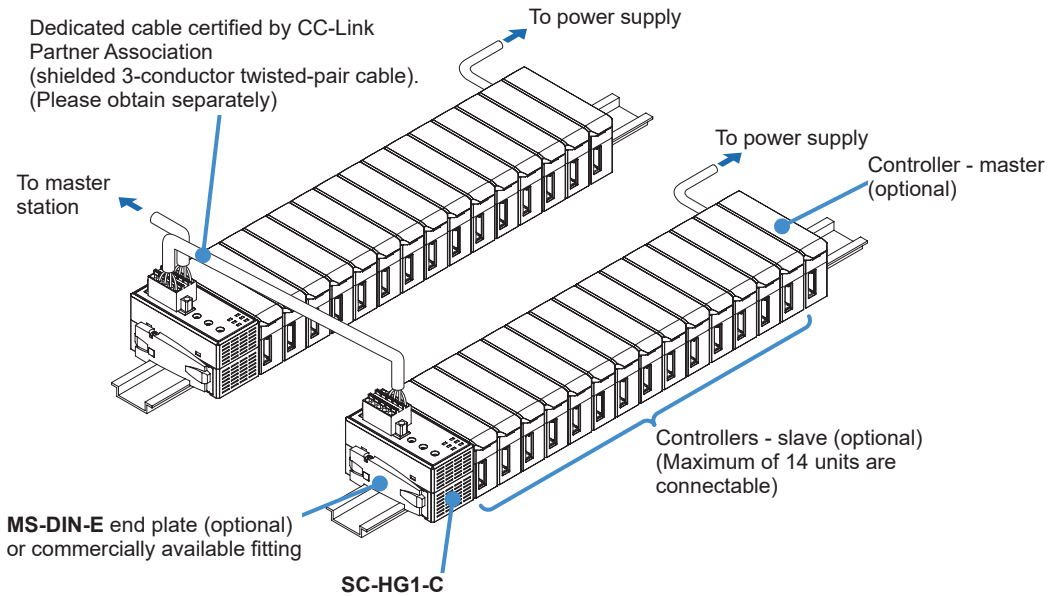

<Reference>

- If **HG-SC** series and **HG-TC** series controllers are used in combination, connect the slave controllers of the same series as the master controller on the near side of the master controller and connect the slave controllers of different series from the master controller on the far side of the master controller.

Example: When the master controller is HG-SC □

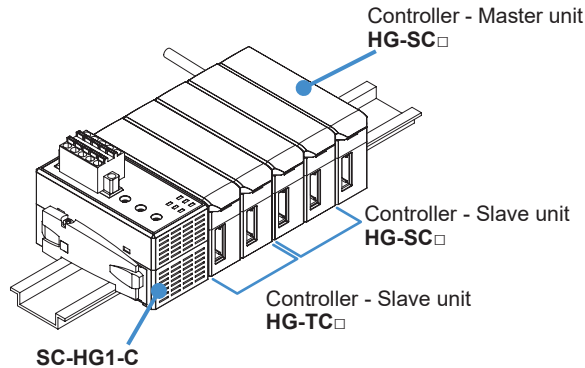

- If **HG-SC** series and **HG-TC** series controllers are used in combination, there are limitations on the functions below.

	Item	Description of limitation
1	Calculation function	Calculation is only performed when the slave unit is the same series as the master unit. Calculation is not performed when the slave unit series is different from the master unit series. "CALC" does not appear in the displays of a slave unit of a different series.
2	Input all	The master unit only performs input all when the slave unit is the same series. A Slave unit of a different series than the master unit are not input even when the external input settings match those of the master unit.
3	Copy function	Copying is only performed when the slave unit is the same series as the master unit. "NOW COPY" appears on the displays of the master unit and slave unit when the slave unit is different series from the master unit, but copying is not performed.
4	Interference prevention	This function is only available on the HG-TC series controller. The function is not executed on the HG-SC series controller.

2-2 Unit types

Communication unit

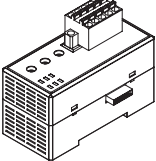
Product name	Appearance	Model
CC-Link communication unit		SC-HG1-C

Controller

● HG-SC series

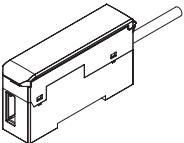
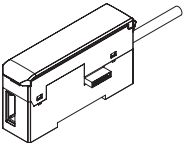
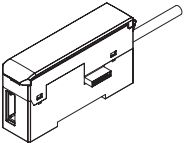
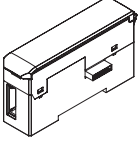
		Type	Appearance	Model	Output
Contact-type digital displacement sensor	Master unit	High-performance type (Analog current) + I/O		HG-SC101	NPN open-collector transistor
				HG-SC101-P	PNP open-collector transistor
	Slave unit	High-performance type (Analog current) + I/O		HG-SC111	NPN open-collector transistor
				HG-SC111-P	PNP open-collector transistor
		Standard type (I/O)		HG-SC112	NPN open-collector transistor
				HG-SC112-P	PNP open-collector transistor
Wire-saving type		HG-SC113	—		



- When connecting slave units to a master unit, connect only NPN output types, or only PNP output types. Dissimilar output types cannot be connected together.
- If an **HG-SC** series controller manufactured in January 2019 or earlier is connected to an **HG-TC** series controller, operation will not take place normally. If they are used together, use an **HG-SC** series controller manufactured in February 2019 or later.

● **HG-TC series**

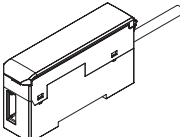
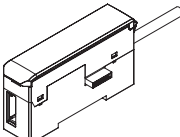
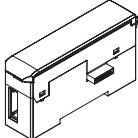
		Type	Appearance	Model	Output
Thru-beam type digital displacement sensor	Master unit	High-performance type (Analog current + I/O)		HG-TC101	NPN open-collector transistor
				HG-TC101-P	PNP open-collector transistor
	Slave unit	High-performance type (Analog current + I/O)		HG-TC111	NPN open-collector transistor
				HG-TC111-P	PNP open-collector transistor
		Wire-saving type		HG-TC113	—

- ⊘
- When connecting slave units to a master unit, connect only NPN output types, or only PNP output types. Dissimilar output types cannot be connected together.
 - If an **HG-SC** series controller manufactured in January 2019 or earlier is connected to an **HG-TC** series controller, operation will not take place normally. If they are used together, connect to an **HG-SC** series controller manufactured in February 2019 or later.

End plate

Product name	Appearance	Model
End plate		MS-DIN-E

(MEMO)

3 Installation and Connections

3-1 Steps prior to operation	3-2
3-2 Settings	3-3
3-2-1 CC-Link communication settings	3-3
3-2-2 Communication unit settings	3-4
3-3 Installation	3-6
3-3-1 Mounting	3-6
3-3-2 Connection	3-7
3-3-3 Pin layout	3-9
3-3-4 Host communication cable connection	3-9
3-3-5 Procedure for connecting the CC-Link connector	3-10
3-3-6 Attachment and removal of termination resistor	3-12

Installation and Settings

3-1 Steps prior to operation

The steps that are required prior to operation are indicated below.

Check column

Page

<input type="checkbox"/>	<p>Station number and communication speed settings</p> <p>Follow the setting procedures to set the product's station number and communication speed.</p>	<p>"3-2-2 Communication unit settings"</p> <p>"3-2-2 Communication unit settings"</p> <p>"2 System Configuration" "3-3-1 Mounting" "3-3-2 Connection"</p> <p>"3-3-3 Pin layout" "3-3-4 Host communication cable connection" "3-3-5 Procedure for connecting the CC-Link connector" "3-3-6 Attachment and removal of termination resistor"</p> <p>"3-2-1 CC-Link communication settings" "4 CC-LINK Network Communication" "4-10-1 HG-S series command list"</p>
<input type="checkbox"/>	<p>Mode settings</p> <p>Follow the setting procedures to set the product's communication method and number of occupied stations.</p>	
<input type="checkbox"/>	<p>Unit mounting</p> <p>Mount the product and controllers on a DIN rail according to the system configuration, and connect.</p>	
<input type="checkbox"/>	<p>Wiring</p> <p>Connect the communication cable and a termination resistor (if needed) to the CC-Link connector, and attach to the product.</p>	
<input type="checkbox"/>	<p>Connect power supply</p> <p>Connect the power supply of the master controller.</p>	
<input type="checkbox"/>	<p>Controller settings</p> <p>Configure controller settings. Configure threshold and other settings by programming or direct setting on the controller. For direct setting on a controller, refer to the manual for the controller.</p>	
<input type="checkbox"/>	<p>Programming</p> <p>Create a program for control of each controller connected to the product from the master station. *1: You can use CSP+ (CC-Link System Profile) to easily configure CC-Link communication settings.</p>	

3-2 Settings

3-2-1 CC-Link communication settings

When connecting the product to a master station, configure the settings below.

<Slave station settings>

Register the product as a remote device station in the master station.

You can use CSP+ (CC-Link System Profile) to easily configure CC-Link communication settings.

CSP+ can be downloaded from the CC-Link Partner Association website.

CC-Link Partner Association website:

<https://www.cc-link.org/sch/c012List?langSeqNo=2&userSeqNo=4&menuSeqNo=2>

<Memory allocation settings>

Change the settings in the master station software to enable communication between the product and master station.

Installation and Settings

3-2-2 Communication unit settings

! After changing the settings, be sure to turn the power OFF and then ON.

Follow the procedure below to configure the settings.

1. Set the station number (1 to 64) with the station number setting switch.

Station number setting switch

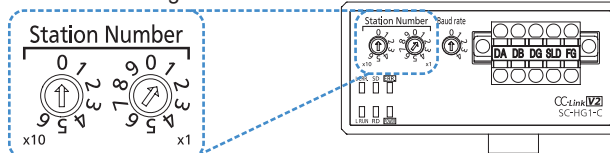

Note: If you set the station number setting switch to 0 or 65 or higher, an error will occur.

2. Set the communication speed with the communication speed setting switch.

Communication speed setting switch

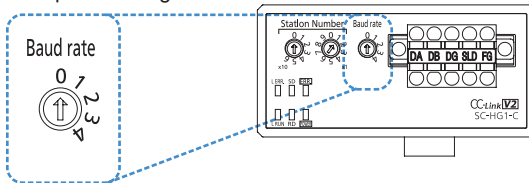

SW No.	Communication speed
0	156kbps (Factory default state)
1	625kbps
2	2.5Mbps
3	5Mbps
4	10Mbps

3. Set the communication method and number of occupied stations with the mode setting switch.

When you have completed the mode setting switch settings, attach the switch cover.

Mode setting switch

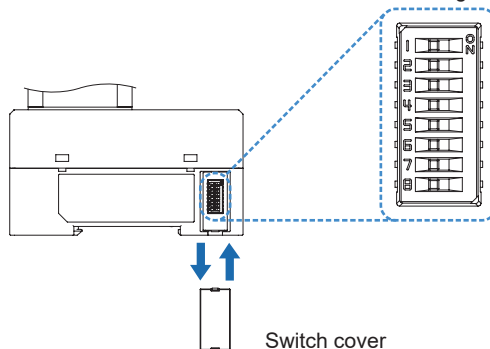

Installation and Settings

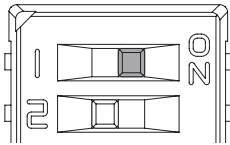
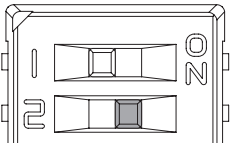
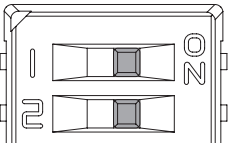
		CC-Link mode 1	CC-Link mode 2	CC-Link mode 3
Mode setting switch				
SW No.	1	ON	OFF	ON
	2	OFF	ON	ON
	3	Not used (Always keep unused switches in the OFF position.)		
	4			
	5			
	6			
	7			
	8			
Remarks		CC-Link Ver.1.10 Number of occupied stations: 4	CC-Link Ver.2.00 Number of occupied stations: 2 Expanded cyclic transmission speed: x8	CC-Link Ver.2.00 Number of occupied stations: 4 Expanded cyclic transmission speed: x4
Number of occupied points	Remote input / output RX / RY	128	384	448
	Remote register RWr / RWw	16	64	64

Installation and Settings

3-3 Installation

3-3-1 Mounting

■ Mounting on a DIN rail

1. Insert the rear of the mounting part into the DIN rail.
2. While pressing down on the rear of the mounting part, insert the front of the mounting part into the DIN rail.

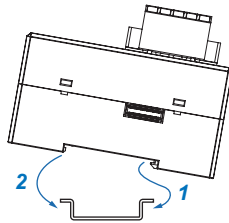

■ Removing from a DIN rail

1. Grasp the product and push forward.
2. Lift the front to remove.

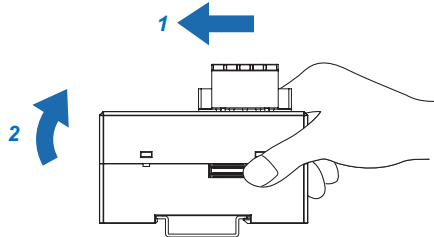

3-3-2 Connection

This product must be connected to a controller.

Up to 15 controllers (one master controller and 14 slave controllers) can be connected to the product.



- Always shut OFF the power before connecting the product to, or disconnecting the product from, a controller. Risk of damage to the product and controller if connected with the power ON.
- Insert the male connector firmly into the female connector.
- Risk of damage to the product and controller if not connected completely.



- To connect the product to a controller, the units must be mounted on a DIN rail. Attach end plates **MS-DIN-E** (optional) so as to enclose the connected units at the ends.

<Reference>

For detailed information on the digital displacement sensor, refer to the manual of the controller that you use.

■ Connection procedure

1. Mount the product on a 35mm width DIN rail.
2. Remove the connector cover from the controller. (Note 1)

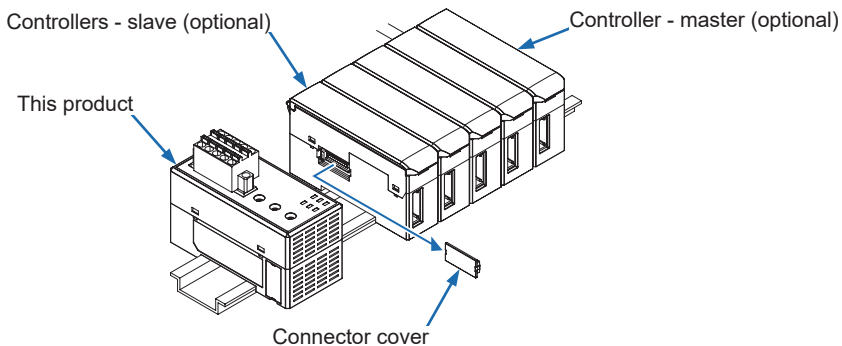

Note 1: Be sure to keep the connector cover you removed from the controller.

3. Slide the product until it directly contacts the controller.

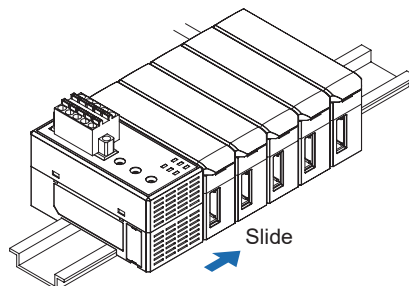

Installation and Settings

4. Attach end plates **MS-DIN-E** (optional) with the flat side facing in so as to enclose the connected units at the ends. (Note 2)

Note 2: If an end plate is attached, the mode setting switch cannot be operated.

5. Tighten the screws to fasten the end plates.

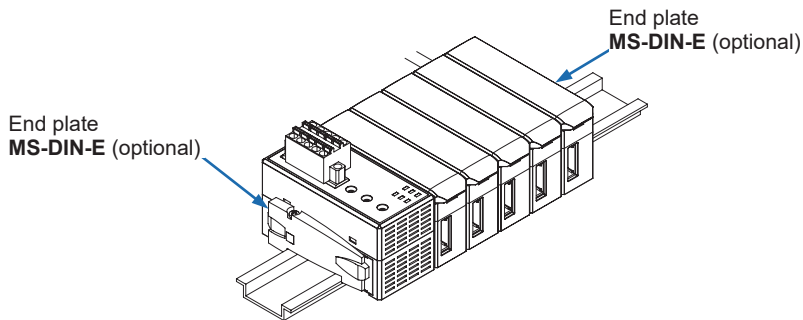

■ Removal procedure

1. Loosen the screws on the end plates.
2. Remove the end plates.
3. Slide and remove the product and controllers.

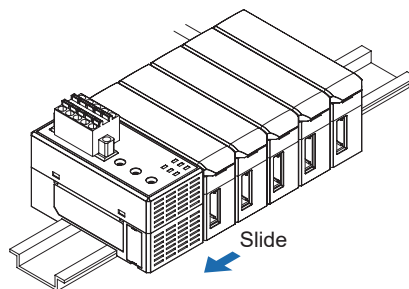

3-3-3 Pin layout

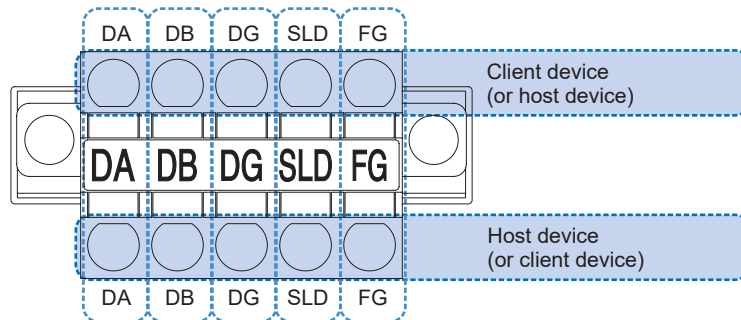

3-3-4 Host communication cable connection



- Make sure that the power supply is OFF while performing wiring work.
- For the communication cable, use a dedicated cable that is certified by CC-Link Partner Association.
- The communication distance must be within the specified range.
- Do not set duplicate station numbers.
- The wiring interval between stations should be at least 200mm.
- For detailed connection specifications, refer to the installation manual published by the CC-Link Partner Association.

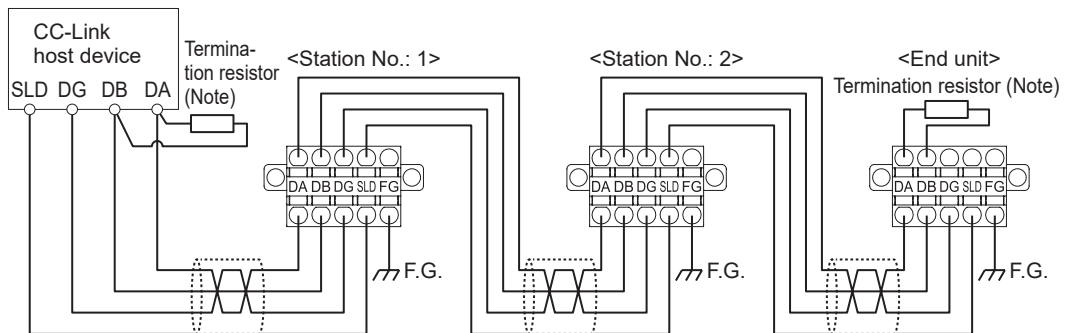

CC-Link dedicated cable wiring

Pin name	Lead wire color
DA	Blue
DB	White
DG	Yellow
SLD	Shield

Note: Select a resistance for the termination resistors that is suitable for the cable, and connect to both end stations of the line connection.
Obtain termination resistors separately.

Installation and Settings

3-3-5 Procedure for connecting the CC-Link connector

For the communication cable, use a CC-Link dedicated cable (shielded, 3-conductor, twisted pair cable).

■ Communication cable work procedure

1. Strip off the jacket on the dedicated cable as shown below. When stripping off the jacket, take care not to damage the shield braid inside the dedicated cable.

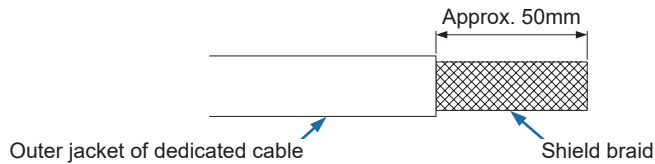

2. Carefully unbraid the shield braid.
3. Firmly twist together the shield and the stranded wire inside the shield braid.
4. Cover the twisted shield wires with insulating tubing (obtain separately).

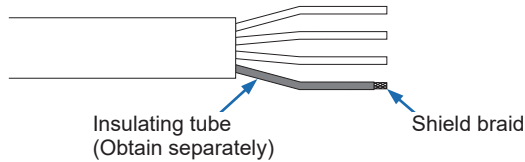

5. Strip off the stranded wire (lead wire) jackets as shown below.

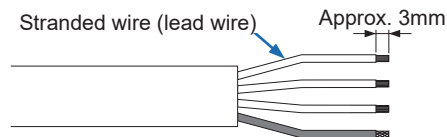

6. Attach ferrule (sleeve) terminals (obtain separately) to the stranded wire (lead wire) and shield wire.

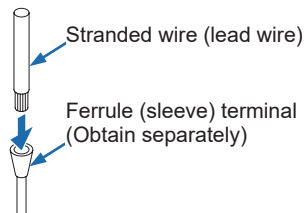

■ Procedure for connecting to the CC-Link connector

Insert the stranded wire (lead wire) in the ferrule (sleeve) terminal fully into the connection hole in the CC-Link connector.

When inserted correctly, the wire is locked and cannot be pulled out. Take care not to pull with excessive force, as the wire may break.

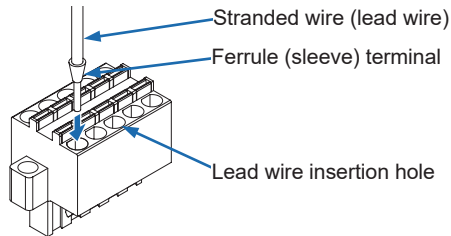

To connect stranded wire (lead wire) to the CC-Link connector without using a ferrule (sleeve) terminal, insert fully into the connection hole while pressing the release button.

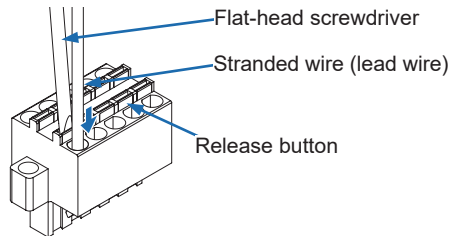

Procedure for removing from the CC-Link connector

To disconnect the stranded (lead) wire, pull out the wire while pressing the release button.

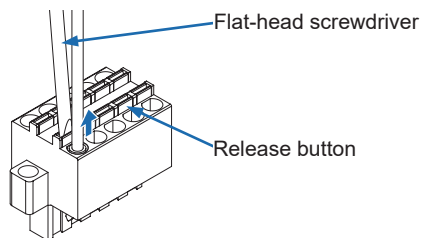

Connecting the CC-Link connector to the product

When attaching the CC-Link connector to the product, tighten to a torque of no more than 0.2N·m.

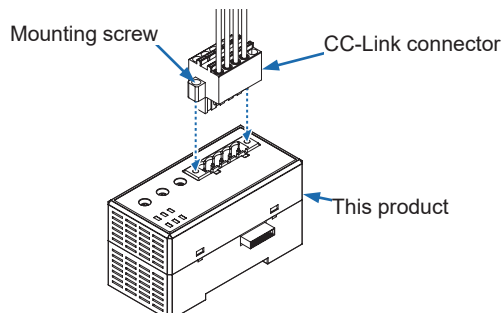

Installation and Settings

3-3-6 Attachment and removal of termination resistor

■ Attaching a termination resistor

Be sure to attach a termination resistor (obtain separately) to the end **SC-HG1-C**. Attach the termination resistor to "DA" and "DB" on the communication connector. To attach, insert sufficiently into the connection hole while pressing the release button.

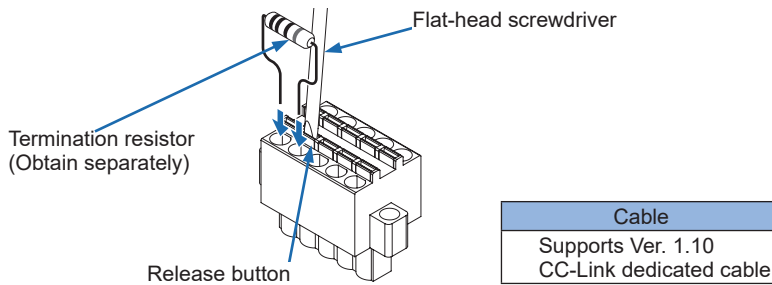

■ Removing the termination resistor

To remove the termination resistor, press the release buttons (x2).

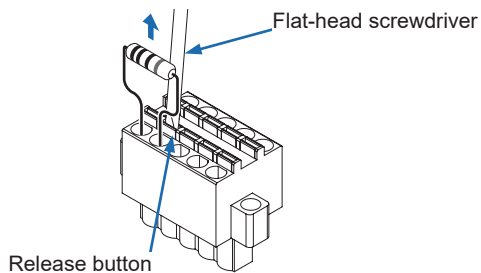

4 CC-LINK Network Communication

4-1 Overview of communication	4-2
4-1-1 Communication with master station	4-2
4-1-2 SC-HG1-C and controller communication	4-3
4-2 Explanation of modes	4-4
4-3 Memory map	4-5
4-3-1 CC-Link mode 1	4-5
4-3-2 CC-Link mode 2	4-14
4-3-3 CC-Link mode 3	4-21
4-4 Memory map and controller assignments	4-28
4-5 Initial operation after power is turned ON	4-29
4-6 Judgment output reading	4-30
4-7 External input	4-30
4-8 Continuous reading of measurement data	4-31
4-9 Error mode	4-33
4-10 Commands	4-34
4-10-1 HG-S series command list	4-34
4-10-2 HG-T series command list	4-39
4-10-3 Command sending procedure	4-50
4-11 Reading received light waveforms (For the HG-T only)	4-54
4-11-1 Format of received light waveform	4-54
4-11-2 Reading measured waveforms	4-56
4-11-3 Reading reference waveforms	4-59
4-12 Registering the reference waveform (For the HG-T only)	4-62
4-13 Communication response speed	4-67
4-14 Self-monitoring Function	4-68
4-14-1 Using the Self-monitoring Function	4-68
4-14-2 Statuses and Measures	4-69
4-15 Other precautions	4-71

4-1 Overview of communication

4-1-1 Communication with master station

Data is exchanged between the communication unit and master station using link devices. There are four types of link devices: “Remote input RX”, “Remote output RY”, “Remote register RWr”, and “Remote register RWw”.

The link device values of each are periodically updated by cyclic transmission. Communication unit functions and link device assignments can be checked using the memory map.

By accessing a link device that supports memory map, the master station can use the functions of a communication unit.

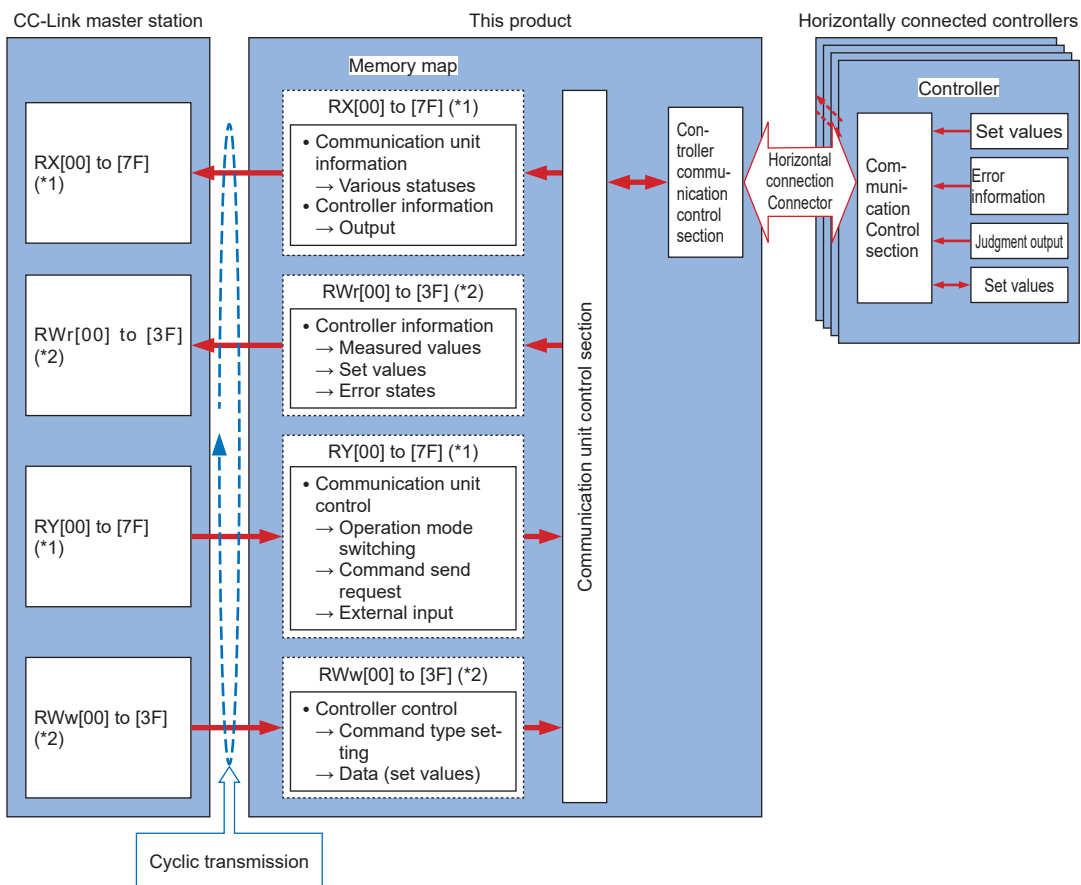

- *1: The bit range depends on the operation mode.
 CC-Link mode 1: RX[00] to RX[7F], RY[00] to RY[7F]
 CC-Link mode 2: RX[00] to RX[17F], RY[00] to RY[17F]
 CC-Link mode 3: RX[00] to RX[1BF], RY[00] to RY[1BF]
- *2: The word range depends on the operation mode.
 CC-Link mode 1: RWr[00] to RWr[0F], RWw[00] to RWw[0F]
 CC-Link mode 2: RWr[00] to RWr[3F], RWw[00] to RWw[3F]
 CC-Link mode 3: RWr[00] to RWr[3F], RWw[00] to RWw[3F]

4-1-2 SC-HG1-C and controller communication

This product automatically converts CC-Link network communication data, and performs communication with connected controllers. CC-Link network communication can be used to read and write input / output and settings of connected controllers.

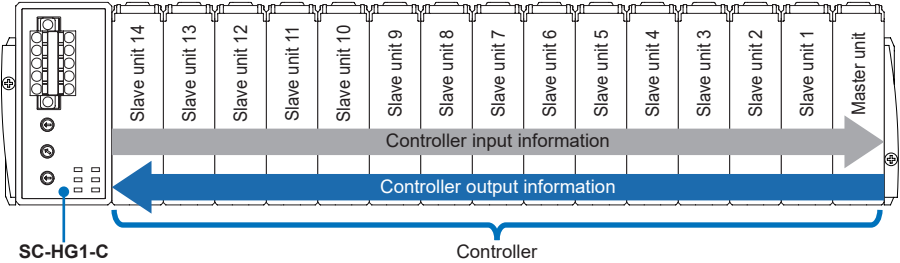

4-2 Explanation of modes

To use this product, CC-Link mode settings are required. Refer to the flow chart below to configure the settings.

Mode selection flow chart

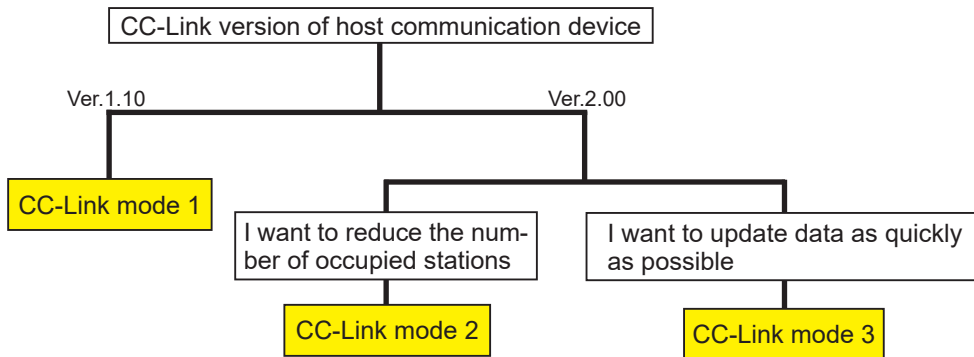

Operation mode details

		CC-Link mode 1	CC-Link mode 2	CC-Link mode 3
Mode setting switch				
SW No.	1	ON	OFF	ON
	2	OFF	ON	ON
	3	Not used (Always keep unused switches in the OFF position.)		
	4			
	5			
	6			
	7			
	8			
Remarks		CC-Link Ver.1.10 Number of occupied stations: 4	CC-Link Ver.2.00 Number of occupied stations: 2 Expanded cyclic transmission speed: x8	CC-Link Ver.2.00 Number of occupied stations: 4 Expanded cyclic transmission speed: x4
Usage requirements		Select when the master station uses CC-Link Ver. 1.10.	Select when the master station uses CC-Link Ver. 2.00 and multiple devices are connected.	Select when the master station uses CC-Link Ver. 2.00 and you want to maximize the data update speed to the master station.
Number of occupied points	Remote input / output RX / RY	128	384	448
	Remote register RWr / RWw	16	64	64

4-3 Memory map

4-3-1 CC-Link mode 1

■ Remote input RX (Mode 1 communication unit → Master station)

This is a read-only register for input from the communication unit to the master station in units of bits.

Values cannot be written to this register.

Before using mode 1, be sure to configure the “page” settings.

For details, refer to “Page settings”.

<Remote input RX>

RX	F	E	D	C	B	A	9	8	7	6	5	4	3	2	1	0	
+00	Sensor response data switching response									Not used						Command response	
	Not used	Error code	Not used	Command	Sensor head value	Calculated value	Normal measured value	Judgment value	Error flag							Send response	
+10	Not used														Page		
															Page 3	Page 2	Page 1
+20	Judgment output 1 (OUT1)																
	Not used	Slave unit 14	Slave unit 13	Slave unit 12	Slave unit 11	Slave unit 10	Slave unit 9	Slave unit 8	Slave unit 7	Slave unit 6	Slave unit 5	Slave unit 4	Slave unit 3	Slave unit 2	Slave unit 1	Master unit	
+30	Judgment output 2 (OUT2)																
	Not used	Slave unit 14	Slave unit 13	Slave unit 12	Slave unit 11	Slave unit 10	Slave unit 9	Slave unit 8	Slave unit 7	Slave unit 6	Slave unit 5	Slave unit 4	Slave unit 3	Slave unit 2	Slave unit 1	Master unit	
+40	Judgment output 3 (OUT3)																
	Not used	Slave unit 14	Slave unit 13	Slave unit 12	Slave unit 11	Slave unit 10	Slave unit 9	Slave unit 8	Slave unit 7	Slave unit 6	Slave unit 5	Slave unit 4	Slave unit 3	Slave unit 2	Slave unit 1	Master unit	
+50	Alarm output																
	Not used	Slave unit 14	Slave unit 13	Slave unit 12	Slave unit 11	Slave unit 10	Slave unit 9	Slave unit 8	Slave unit 7	Slave unit 6	Slave unit 5	Slave unit 4	Slave unit 3	Slave unit 2	Slave unit 1	Master unit	
+60	Error output																
	Communication unit	Slave unit 14	Slave unit 13	Slave unit 12	Slave unit 11	Slave unit 10	Slave unit 9	Slave unit 8	Slave unit 7	Slave unit 6	Slave unit 5	Slave unit 4	Slave unit 3	Slave unit 2	Slave unit 1	Master unit	
+70	Not used				Remote ready	Error state	Setting initialization done	Initialization request	Not used								

<Setting details>

	Name	Device No.	Description
Command response	Send response	RX[00]	RY[00]: Response bit to a send request. This bit is set when transmission of a command to a controller is completed.
	Error flag	RX[01]	This bit is set when the command response from a controller is an error.
Sensor response data switching response (*1)(*2)	Judgment value (*3)	RX[08]	RY[08]: Response bit to a judgment value. This bit is set when judgment value mode is entered.
	Normal measured value (*3)	RX[09]	RY[09]: Response bit to a normal measured value. This bit is set when normal measured value mode is entered.
	Calculated value (*3)	RX[0A]	RY[0A]: Response bit to a calculated value. This bit is set when calculated value mode is entered.
	Sensor head value (*3)	RX[0B]	RY[0B]: Response bit to a sensor head value. This bit is set when sensor head value mode is entered.
	Command	RX[0C]	RY[0C]: Response bit to a command. This bit is set when command mode is entered.
	Error code	RX[0E]	RY[0E]: Response bit to an error code. This bit is set when error mode is entered.

CC-LINK Network Communication

Name		Device No.	Description
Page1 to page3 (*4) (*5)		RX[10] to [12]	RY[10] to [12]: Response bit to pages 1 to 3. The bits corresponding to the current page settings are set.
Judgment output 1 (OUT1)		RX[20] to [2E]	Status of output 1 (OUT1) of a connected controller. This bit is set when the output is ON.
Judgment output 2 (OUT2)		RX[30] to [3E]	Status of output 2 (OUT2) of a connected controller. This bit is set when the output is ON.
Judgment output 3 (OUT3)		RX[40] to [4E]	Status of output 3 (OUT3) of a connected controller. This bit is set when the output is ON.
Alarm output (*6)		RX[50] to [5E]	Status of the alarm output of a connected controller. This bit is set when the output is ON.
Error output		RX[60] to [6F]	Status of the error output of a connected controller or the communication unit. When an error occurs, the corresponding bit is set.
System area	Initialization request	RX[78]	This bit is set when the product issues an initialization request to the master station. This is not used on the product.
	Setting initialization done	RX[79]	RY[79]: Response bit to an initialize settings request. This bit is set when initialization of the settings is completed.
	Error state	RX[7A]	When an error occurs, this bit is set. The bit is cleared when the error is cleared.
	Remote ready	RX[7B]	This bit is set when preparation for communication is completed. The bit is cleared when preparation for communication is not completed or an error has occurred.

- *1: RY[08] to [0C], RY[0E]: when all sensor response data switch request bits are cleared, RX[08]: judgment value is set.
- *2: RY[08] to [0C], RY[0E]: when multiple bits are set for a sensor response data switch request, a response to the request with the lowest bit number is set.
- *3: For information on judgment values, normal measured values, calculated values, and sensor head values, refer to the user's manual of the controller that you use.
- *4: RX[10] to [12]: if all bits of pages 1 to 3 are cleared, controller assignments in the memory map become undefined. Always set the page settings. For details, refer to **"Page settings"**.
- *5: RY[10] to [12]: when multiple bits are set for pages 1 to 3, a response to the page with the lowest bit number is set.
- *6: Controller-specific function. Refer to the user's manual of the controller that you use.
- *7: Values read in unused areas are not defined.

■ Remote register RWr (Mode 1 communication unit → Master station)

This is a read-only register for input from the communication unit to the master station in units of words (16 bits).

Values cannot be written to this register.

Controller assignments are changed to RWr[02] to [0F]: sensor response data depending on the RY[10] to [12]: page 1 to 3 setting. For details, refer to “Page settings”.

<Remote register RWr>

RWr	Page 1															
	F	E	D	C	B	A	9	8	7	6	5	4	3	2	1	0
+00	When judgment value / normal measured value / calculated value / sensor head value mode is set → 0x0000 (fixed value)															
	When error mode is set → Communication unit error code (lower word)															
	Not used	When command mode is set → Command response sensor														
+01	When judgment value / normal measured value / calculated value / sensor head value mode is set → 0x0000 (fixed value)															
	When error mode is set → Communication unit error code (upper word)															
	When command mode is set → Command response code															
+02	Sensor response data															
+03	Master unit (32 bits)															
+04	Sensor response data															
+05	Slave unit 1 (32 bits)															
+06	Sensor response data															
+07	Slave unit 2 (32 bits)															
+08	Sensor response data															
+09	Slave unit 3 (32 bits)															
+0A	Sensor response data															
+0B	Slave unit 4 (32 bits)															
+0C	Sensor response data															
+0D	Slave unit 5 (32 bits)															
+0E	Sensor response data															
+0F	Slave unit 6 (32 bits)															

RWr	Page 2															
	F	E	D	C	B	A	9	8	7	6	5	4	3	2	1	0
+00	When judgment value / normal measured value / calculated value / sensor head value mode is set → 0x0000 (fixed value)															
	When error mode is set → Communication unit error code (lower word)															
	Not used	When command mode is set → Command response sensor														
+01	When judgment value / normal measured value / calculated value / sensor head value mode is set → 0x0000 (fixed value)															
	When error mode is set → Communication unit error code (upper word)															
	When command mode is set → Command response code															
+02	Sensor response data															
+03	Slave unit 7 (32 bits)															
+04	Sensor response data															
+05	Slave unit 8 (32 bits)															
+06	Sensor response data															
+07	Slave unit 9 (32 bits)															
+08	Sensor response data															
+09	Slave unit 10 (32 bits)															
+0A	Sensor response data															
+0B	Slave unit 11 (32 bits)															
+0C	Sensor response data															
+0D	Slave unit 12 (32 bits)															
+0E	Sensor response data															
+0F	Slave unit 13 (32 bits)															

CC-LINK Network Communication

RWr	Page 3															
	F	E	D	C	B	A	9	8	7	6	5	4	3	2	1	0
+00	When judgment value / normal measured value / calculated value / sensor head value mode is set → 0x0000 (fixed value)															
	When error mode is set → Communication unit error code (lower word)															
	Not used	Slave unit 14	Slave unit 13	Slave unit 12	Slave unit 11	Slave unit 10	Slave unit 9	Slave unit 8	Slave unit 7	Slave unit 6	Slave unit 5	Slave unit 4	Slave unit 3	Slave unit 2	Slave unit 1	Master unit
+01	When judgment value / normal measured value / calculated value / sensor head value mode is set → 0x0000 (fixed value)															
	When error mode is set → Communication unit error code (upper word)															
	When command mode is set → Command response code															
+02	Sensor response data															
+03	Slave unit 14 (32 bits)															
+04	Not used															
+05																
+06																
+07																
+08																
+09																
+0A																
+0B																
+0C																
+0D																
+0E																
+0F																

*1: Values read in unused areas are not defined.

<Setting details>

Name	Device No.	Description
Command response sensor	RWr[00]	<ul style="list-style-type: none"> When judgment value / normal measured value / calculated value / sensor head value mode is set → fixed value 0x0000 is stored When command mode is set → The bit corresponding to the controller which returned a response to a command is set. When error mode is set → The communication unit error code (lower word) is stored.
Command response code	RWr[01]	<ul style="list-style-type: none"> When judgment value / normal measured value / calculated value / sensor head value mode is set → fixed value 0x0000 is stored When command mode is set → The command code sent to the controller is stored. When error mode is set → The communication unit error code (upper word) is stored.
Sensor response data	RWr[02] to [0F]	<ul style="list-style-type: none"> The response data from the controller to which a command or mode was sent is stored.

■ Remote output RY (Mode 1 master station → Communication unit)

This is a write-only register for output from the master station to the communication unit in units of bits.

Before using mode 1, be sure to configure the “page” settings.

For details, refer to “Page settings”.

<Remote output RY>

RY	F	E	D	C	B	A	9	8	7	6	5	4	3	2	1	0	
+00	Sensor response data switching request									Not used						Command request	
	Not used	Error code	Not used	Command	Sensor head value	Calculated value	Normal measured value	Judgment value	Write flag							Send request	
+10	Not used														Page		
															Page 3	Page 2	Page 1
+20	Not used	External input 1 (IN1)															
		Slave unit 14	Slave unit 13	Slave unit 12	Slave unit 11	Slave unit 10	Slave unit 9	Slave unit 8	Slave unit 7	Slave unit 6	Slave unit 5	Slave unit 4	Slave unit 3	Slave unit 2	Slave unit 1	Master unit	
+30	Not used	External input 2 (IN2)															
		Slave unit 14	Slave unit 13	Slave unit 12	Slave unit 11	Slave unit 10	Slave unit 9	Slave unit 8	Slave unit 7	Slave unit 6	Slave unit 5	Slave unit 4	Slave unit 3	Slave unit 2	Slave unit 1	Master unit	
+40	Not used	External input 3 (IN3)															
		Slave unit 14	Slave unit 13	Slave unit 12	Slave unit 11	Slave unit 10	Slave unit 9	Slave unit 8	Slave unit 7	Slave unit 6	Slave unit 5	Slave unit 4	Slave unit 3	Slave unit 2	Slave unit 1	Master unit	
+50	Not used																
+60	Not used																
+70	Not used						Error clear request	Setting initialization request	Initialization done	Not used							

<Setting details>

	Name	Device No.	Description
Command request	Send request	RY[00]	Send command to controller request bit. When this bit is set, a command is sent. To send a subsequent command, clear the bit and then set again.
	Write flag	RY[01]	To execute a read command, clear this bit. To execute a write command, set this bit. RY[00]: Set before a send request.
Sensor response data switching request (*1) (*2)	Judgment value (*3)	RY[08]	Change to judgment value mode. When the bit is set, the mode changes to judgment value mode.
	Normal measured value (*3)	RY[09]	Change to normal measured value mode. When the bit is set, the mode changes to normal measured value mode.
	Calculated value (*3)	RY[0A]	Change to calculated value mode. When the bit is set, the mode changes to calculated value mode.
	Sensor head value (*3)	RY[0B]	Change to sensor head value mode. When the bit is set, the mode changes to sensor head value mode.
	Command	RY[0C]	Change to command mode. When this bit is set, changing to command mode and sending commands is allowed. Set before a command request (RY[00]: send request).
	Error code	RY[0E]	Change to error mode. When this bit is set, the mode changes to error mode.
Page1 to page3 (*4) (*5)		RY[10] to [12]	Changes the controller assignment in the memory map. When this bit is set, the controller assignment changes to the assignment of the set page settings.
External input 1 (IN1) (*6)		RY[20] to [2E]	Controls external input 1 on the controller. When this bit is set, external input 1 turns ON.

CC-LINK Network Communication

Name		Description
External input 2 (IN2) (*6)	RY[30] to [3E]	Controls external input 2 on the controller. When this bit is set, external input 2 turns ON.
External input 3 (IN3) (*6)	RY[40] to [4E]	Controls external input 3 on the controller. When this bit is set, external input 3 turns ON.
Initialization done	RY[78]	This bit is set as a response when the product issues an initialization request to the master station. This is not used because the product does not issue initialization requests.
Setting initialization request	RY[79]	This bit is set when initialization of the product's settings is repeated.
Error clear request	RY[7A]	When an error occurs, this bit is set to clear the error.

- *1: RY[08] to [0C], RY[0E]: when all sensor response data switch request bits are cleared, the RY[08]: judgment value bit is set and the corresponding operation takes place.
- *2: RY[08] to [0C], RY[0E]: when multiple bits are set for a sensor response data switch request, the request with the lowest bit number is given priority.
- *3: For information on judgment values, normal measured values, calculated values, and sensor head values, refer to the user's manual of the controller that you use.
- *4: Controllers are assigned to the memory map according to the page settings set in RY[10] to [12]. If the page settings are not set, controllers are not assigned to the remote registers (RW_r, RW_w). Always set the page settings. For details, refer to "**Page settings**".
- *5: RY[10] to [12]: when multiple bits are set for pages 1 to 3, the settings for the page with the lowest bit number are valid.
- *6: Operation depends on the controller set value. To use external input, refer to the user's manual of the controller that you use.
- *7: If it is necessary to use an unused area, always set to "0".

■ Remote register RWw (Mode 1 master station → Communication unit)

This is a write-only register for output from the master station to the communication unit in units of words (16 bits).

Controller assignments are changed to RWw[02] to [0F]: sensor response data depending on the RY[10] to [12]: page 1 to 3 setting. For details, refer to “Page settings”.

<Remote register RWw>

RWw	Page 1															
	F	E	D	C	B	A	9	8	7	6	5	4	3	2	1	0
+00	Not used	Command request sensor														
		Slave unit 14	Slave unit 13	Slave unit 12	Slave unit 11	Slave unit 10	Slave unit 9	Slave unit 8	Slave unit 7	Slave unit 6	Slave unit 5	Slave unit 4	Slave unit 3	Slave unit 2	Slave unit 1	Master unit
+01	Command code															
+02	Command data															
+03	Master unit (32 bits)															
+04	Command data															
+05	Slave unit 1 (32 bits)															
+06	Command data															
+07	Slave unit 2 (32 bits)															
+08	Command data															
+09	Slave unit 3 (32 bits)															
+0A	Command data															
+0B	Slave unit 4 (32 bits)															
+0C	Command data															
+0D	Slave unit 5 (32 bits)															
+0E	Command data															
+0F	Slave unit 6 (32 bits)															

RWw	Page 2															
	F	E	D	C	B	A	9	8	7	6	5	4	3	2	1	0
+00	Not used	Command request sensor														
		Slave unit 14	Slave unit 13	Slave unit 12	Slave unit 11	Slave unit 10	Slave unit 9	Slave unit 8	Slave unit 7	Slave unit 6	Slave unit 5	Slave unit 4	Slave unit 3	Slave unit 2	Slave unit 1	Master unit
+01	Command code															
+02	Command data															
+03	Slave unit 7 (32 bits)															
+04	Command data															
+05	Slave unit 8 (32 bits)															
+06	Command data															
+07	Slave unit 9 (32 bits)															
+08	Command data															
+09	Slave unit 10 (32 bits)															
+0A	Command data															
+0B	Slave unit 11 (32 bits)															
+0C	Command data															
+0D	Slave unit 12 (32 bits)															
+0E	Command data															
+0F	Slave unit 13 (32 bits)															

CC-LINK Network Communication

RWw	Page 3															
	F	E	D	C	B	A	9	8	7	6	5	4	3	2	1	0
+00	Not used	Command request sensor														
		Slave unit 14	Slave unit 13	Slave unit 12	Slave unit 11	Slave unit 10	Slave unit 9	Slave unit 8	Slave unit 7	Slave unit 6	Slave unit 5	Slave unit 4	Slave unit 3	Slave unit 2	Slave unit 1	Master unit
+01	Command code															
+02	Command data															
+03	Slave unit 14 (32 bits)															
+04	Not used															
+05																
+06																
+07																
+08																
+09																
+0A																
+0B																
+0C																
+0D																
+0E																
+0F																

<Setting details>

Name	Device No.	Description
Command request sensor	RWw[00]	Specify the controller for sending a command. The command is sent to the controller whose bit is set.
Command code	RWw[01]	Set the command code to be sent to the controller.
Command data	RWw[02] to [0F]	Set the controller set value according to the command to be sent.

*1: If it is necessary to use the unused area, always set to "0".

■ Page settings

Before using the product in CC-Link mode 1, be sure to configure the page settings.

The page settings set the controller assignments in the remote registers (RW_r, RW_w).

If the page settings are not set, controllers are not assigned to the remote registers (RW_r, RW_w) and data such as controller judgment values cannot be exchanged.

When the power is turned on, the page settings are not set {RY[10] to [12] = (0,0,0), RX[10] to [12] = (0,0,0)}.

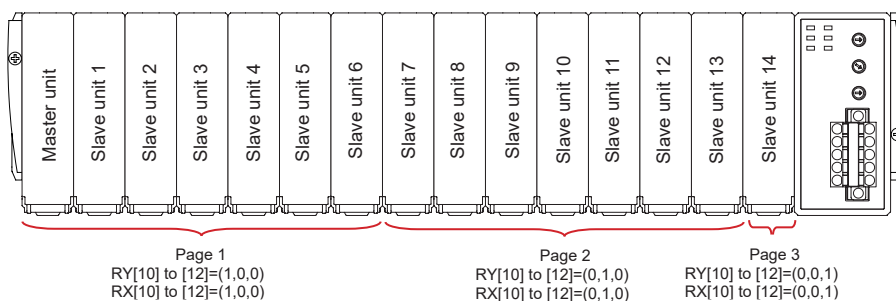

RW _r / RW _w	Memory map (remote register)			
	Not set	Page 1	Page 2	Page 3
+00	The controller data area has not been assigned. Configure the page settings.	In command mode → Command response sensor / command request sensor		
+01		In command mode → Command response code / command code		
+02		Master unit Data	Slave unit 7 Data	Slave unit 14 Data
+03		Slave unit 1 Data	Slave unit 8 Data	Not used
+04		Slave unit 2 Data	Slave unit 9 Data	
+05		Slave unit 3 Data	Slave unit 10 Data	
+06		Slave unit 4 Data	Slave unit 11 Data	
+07		Slave unit 5 Data	Slave unit 12 Data	
+08		Slave unit 6 Data	Slave unit 13 Data	
+09				
+0A				
+0B				
+0C				
+0D				
+0E				
+0F				

If multiple page settings are set, the request with the lowest bit number is given priority.

Example: If remote outputs page 2 and page 3 {RY[10] to [12] = (0,1,1)} are set, page 2 (RY[11]) is given priority.

4-3-2 CC-Link mode 2

Remote input RX (Mode 2 communication unit → Master station)

This is a read-only register for input from the communication unit to the master station in units of bits.

Values cannot be written to this register.

<Remote input RX>

RX	F	E	D	C	B	A	9	8	7	6	5	4	3	2	1	0	
+00	Sensor response data switching response									Not used						Command response	
	Not used	Error code	Not used	Command	Sensor head value	Calculated value	Normal measured value	Judgment value	Error flag							Send response	
+10	Not used																
+20	Judgment output 1 (OUT1)																
	Not used	Slave unit 14	Slave unit 13	Slave unit 12	Slave unit 11	Slave unit 10	Slave unit 9	Slave unit 8	Slave unit 7	Slave unit 6	Slave unit 5	Slave unit 4	Slave unit 3	Slave unit 2	Slave unit 1	Master unit	
+30	Judgment output 2 (OUT2)																
	Not used	Slave unit 14	Slave unit 13	Slave unit 12	Slave unit 11	Slave unit 10	Slave unit 9	Slave unit 8	Slave unit 7	Slave unit 6	Slave unit 5	Slave unit 4	Slave unit 3	Slave unit 2	Slave unit 1	Master unit	
+40	Judgment output 3 (OUT3)																
	Not used	Slave unit 14	Slave unit 13	Slave unit 12	Slave unit 11	Slave unit 10	Slave unit 9	Slave unit 8	Slave unit 7	Slave unit 6	Slave unit 5	Slave unit 4	Slave unit 3	Slave unit 2	Slave unit 1	Master unit	
+50	Alarm output																
	Not used	Slave unit 14	Slave unit 13	Slave unit 12	Slave unit 11	Slave unit 10	Slave unit 9	Slave unit 8	Slave unit 7	Slave unit 6	Slave unit 5	Slave unit 4	Slave unit 3	Slave unit 2	Slave unit 1	Master unit	
+60	Error output																
	Communication unit	Slave unit 14	Slave unit 13	Slave unit 12	Slave unit 11	Slave unit 10	Slave unit 9	Slave unit 8	Slave unit 7	Slave unit 6	Slave unit 5	Slave unit 4	Slave unit 3	Slave unit 2	Slave unit 1	Master unit	
+70	Not used																
?	Not used																
+160	Not used																
+170	Not used				Remote ready	Error state	Setting initialization done	Initialization request	Not used								

<Setting details>

	Name	Device No.	Description
Command response	Send response	RX[00]	RY[00]: Response bit to a send request. This bit is set when transmission of a command to a controller is completed.
	Error flag	RX[01]	This bit is set when the command response from a controller is an error.
Sensor response data switching response (*1)(*2)	Judgment value (*3)	RX[08]	RY[08]: Response bit to a judgment value. This bit is set when judgment value mode is entered.
	Normal measured value (*3)	RX[09]	RY[09]: Response bit to a normal measured value. This bit is set when normal measured value mode is entered.
	Calculated value (*3)	RX[0A]	RY[0A]: Response bit to a calculated value. This bit is set when calculated value mode is entered.
	Sensor head value (*3)	RX[0B]	RY[0B]: Response bit to a sensor head value. This bit is set when sensor head value mode is entered.
	Command	RX[0C]	RY[0C]: Response bit to a command. This bit is set when command mode is entered.
	Error code	RX[0E]	RY[0E]: Response bit to an error code. This bit is set when error mode is entered.

Name	Device No.	Description	
Judgment output 1 (OUT1)	RX[20] to [2E]	Status of output 1 (OUT1) of a connected controller. This bit is set when the output is ON.	
Judgment output 2 (OUT2)	RX[30] to [3E]	Status of output 2 (OUT2) of a connected controller. This bit is set when the output is ON.	
Judgment output 3 (OUT3)	RX[40] to [4E]	Status of output 3 (OUT3) of a connected controller. This bit is set when the output is ON.	
Alarm output (*4)	RX[50] to [5E]	Status of the alarm output of a connected controller. This bit is set when the output is ON.	
Error output	RX[60] to [6F]	Status of the error output of a connected controller or the communication unit. When an error occurs, the corresponding bit is set.	
System area	Initialization request	RX[178]	This bit is set when the product issues an initialization request to the master station. This is not used on the product.
	Setting initialization done	RX[179]	RY[179]: Response bit to an initialize settings request. This bit is set when initialization of the settings is completed.
	Error state	RX[17A]	When an error occurs, this bit is set. The bit is cleared when the error is cleared.
	Remote ready	RX[17B]	This bit is set when preparation for communication is completed. The bit is cleared when preparation for communication is not completed or an error has occurred.

*1: RY[08] to [0C], RY[0E]: when all sensor response data switch request bits are cleared, RX[08]: judgment value is set.

*2: RY[08] to [0C], RY[0E]: when multiple bits are set for a sensor response data switch request, a response to the request with the lowest bit number is set.

*3: For information on judgment values, normal measured values, calculated values, and sensor head values, refer to the user's manual of the controller that you use.

*4: Controller-specific function. Refer to the user's manual of the controller that you use.

*5: Values read in unused areas are not defined.

■ Remote register RWr (Mode 2 communication unit → Master station)

This is a read-only register for input from the communication unit to the master station in units of words (16 bits).

Values cannot be written to this register.

<Remote register RWr>

RWr	F	E	D	C	B	A	9	8	7	6	5	4	3	2	1	0
+00	When judgment value / normal measured value / calculated value / sensor head value mode is set → 0x0000 (fixed value)															
	When error mode is set → Communication unit error code (lower word)															
	Not used	When command mode is set → Command response sensor														
+01	When judgment value / normal measured value / calculated value / sensor head value mode is set → 0x0000 (fixed value)															
	When error mode is set → Communication unit error code (upper word)															
+02	When command mode is set → Command response code															
+03	Sensor response data Master unit (32 bits)															
+04	Sensor response data Slave unit 1 (32 bits)															
+05	Sensor response data Slave unit 2 (32 bits)															
+06	Sensor response data Slave unit 3 (32 bits)															
+07	Sensor response data Slave unit 4 (32 bits)															
+08	Sensor response data Slave unit 5 (32 bits)															
+09	Sensor response data Slave unit 6 (32 bits)															
+0A	Sensor response data Slave unit 7 (32 bits)															
+0B	Sensor response data Slave unit 8 (32 bits)															
+0C	Sensor response data Slave unit 9 (32 bits)															
+0D	Sensor response data Slave unit 10 (32 bits)															
+0E	Sensor response data Slave unit 11 (32 bits)															
+0F	Sensor response data Slave unit 12 (32 bits)															
+10	Sensor response data Slave unit 13 (32 bits)															
+11	Sensor response data Slave unit 14 (32 bits)															
+12	Sensor response data Slave unit 1 (32 bits)															
+13	Sensor response data Slave unit 2 (32 bits)															
+14	Sensor response data Slave unit 3 (32 bits)															
+15	Sensor response data Slave unit 4 (32 bits)															
+16	Sensor response data Slave unit 5 (32 bits)															
+17	Sensor response data Slave unit 6 (32 bits)															
+18	Sensor response data Slave unit 7 (32 bits)															
+19	Sensor response data Slave unit 8 (32 bits)															
+1A	Sensor response data Slave unit 9 (32 bits)															
+1B	Sensor response data Slave unit 10 (32 bits)															
+1C	Sensor response data Slave unit 11 (32 bits)															
+1D	Sensor response data Slave unit 12 (32 bits)															
+1E	Sensor response data Slave unit 13 (32 bits)															
+1F	Sensor response data Slave unit 14 (32 bits)															
+20	Not used															
?	Not used															
+3F	Not used															

<Setting details>

Name	Device No.	Description
Command response sensor	RWr[00]	<ul style="list-style-type: none"> ● When judgment value / normal measured value / calculated value / sensor head value mode is set → fixed value 0x0000 is stored ● When command mode is set → The bit corresponding to the controller which returned a response to a command is set. ● When error mode is set → The communication unit error code (lower word) is stored.
Command response code	RWr[01]	<ul style="list-style-type: none"> ● When judgment value / normal measured value / calculated value / sensor head value mode is set → fixed value 0x0000 is stored ● When command mode is set → The command code sent to the controller is stored. ● When error mode is set → The communication unit error code (upper word) is stored.
Sensor response data	RWr[02] to [1F]	<ul style="list-style-type: none"> ● The response data from the controller to which a command or mode was sent is stored.

*1: Values read in unused areas are not defined.

■ Remote output RY (Mode 2 Master station → Communication unit)

This is a write-only register for output from the master station to the communication unit in units of bits.

<Remote output RY>

RY	F	E	D	C	B	A	9	8	7	6	5	4	3	2	1	0	
+00	Sensor response data switching request									Not used						Command request	
	Not used	Error code	Not used	Command	Sensor head value	Calculated value	Normal measured value	Judgment value	Write flag							Send request	
+10	Not used																
+20	External input 1 (IN1)																
	Not used	Slave unit 14	Slave unit 13	Slave unit 12	Slave unit 11	Slave unit 10	Slave unit 9	Slave unit 8	Slave unit 7	Slave unit 6	Slave unit 5	Slave unit 4	Slave unit 3	Slave unit 2	Slave unit 1	Master unit	
+30	External input 2 (IN2)																
	Not used	Slave unit 14	Slave unit 13	Slave unit 12	Slave unit 11	Slave unit 10	Slave unit 9	Slave unit 8	Slave unit 7	Slave unit 6	Slave unit 5	Slave unit 4	Slave unit 3	Slave unit 2	Slave unit 1	Master unit	
+40	External input 3 (IN3)																
	Not used	Slave unit 14	Slave unit 13	Slave unit 12	Slave unit 11	Slave unit 10	Slave unit 9	Slave unit 8	Slave unit 7	Slave unit 6	Slave unit 5	Slave unit 4	Slave unit 3	Slave unit 2	Slave unit 1	Master unit	
+50	Not used																
?	Not used																
+160	Not used																
+170	Not used					Error clear request	Setting initialization request	Initialization done	Not used								

<Setting details>

	Name	Device No.	Description
Command request	Send request	RY[00]	Send command to controller request bit. When this bit is set, a command is sent. To send a subsequent command, clear the bit and then set again.
	Write flag	RY[01]	To execute a read command, clear this bit. To execute a write command, set this bit. RY[00]: Set before a send request.
Sensor response data switching request (*1)(*2)	Judgment value (*3)	RY[08]	Change to judgment value mode. When the bit is set, the mode changes to judgment value mode.
	Normal measured value (*3)	RY[09]	Change to normal measured value mode. When the bit is set, the mode changes to normal measured value mode.
	Calculated value (*3)	RY[0A]	Change to calculated value mode. When the bit is set, the mode changes to calculated value mode.
	Sensor head value (*3)	RY[0B]	Change to sensor head value mode. When the bit is set, the mode changes to sensor head value mode.
	Command	RY[0C]	Change to command mode. When this bit is set, changing to command mode and sending commands is allowed. Set before a command request (RY[00]: send request).
	Error code	RY[0E]	Change to error mode. When this bit is set, the mode changes to error mode.
External input 1 (IN1) (*4)	RY[20] to [2E]	Controls external input 1 on the controller. When this bit is set, external input 1 turns ON.	
External input 2 (IN2) (*4)	RY[30] to [3E]	Controls external input 2 on the controller. When this bit is set, external input 2 turns ON.	
External input 3 (IN3) (*4)	RY[40] to [4E]	Controls external input 3 on the controller. When this bit is set, external input 3 turns ON.	

Name		Description
Initialization done	RY[178]	This bit is set as a response when the product issues an initialization request to the master station. This is not used because the product does not issue initialization requests.
Setting initialization request	RY[179]	Set this bit to repeat initialization of the product's settings.
Error clear request	RY[17A]	When an error occurs, this bit is set to clear the error.

- *1: RY[08] to [0C], RY[0E]: when all sensor response data switch request bits are cleared, the RY[08]: judgment value bit is set and the corresponding operation takes place.
- *2: RY[08] to [0C], RY[0E]: when multiple bits are set for a sensor response data switch request, the request with the lowest bit number is given priority.
- *3: For information on judgment values, normal measured values, calculated values, and sensor head values, refer to the user's manual of the controller that you use.
- *4: Operation depends on the controller set value. To use external input, refer to the user's manual of the controller that you use.
- *5: If it is necessary to use the unused area, always set to "0".

■ Remote register RWw (Mode 2 master station → Communication unit)

This is a write-only register for output from the master station to the communication unit in units of words (16 bits).

<Remote register RWw>

RWw	F	E	D	C	B	A	9	8	7	6	5	4	3	2	1	0
+00	Not used	Slave unit 14	Slave unit 13	Slave unit 12	Slave unit 11	Slave unit 10	Slave unit 9	Slave unit 8	Slave unit 7	Slave unit 6	Slave unit 5	Slave unit 4	Slave unit 3	Slave unit 2	Slave unit 1	Master unit
+01	Command request sensor															
+02	Command code															
+03	Command data Master unit (32 bits)															
+04	Command data Slave unit 1 (32 bits)															
+05	Command data Slave unit 2 (32 bits)															
+06	Command data Slave unit 3 (32 bits)															
+07	Command data Slave unit 4 (32 bits)															
+08	Command data Slave unit 5 (32 bits)															
+09	Command data Slave unit 6 (32 bits)															
+0A	Command data Slave unit 7 (32 bits)															
+0B	Command data Slave unit 8 (32 bits)															
+0C	Command data Slave unit 9 (32 bits)															
+0D	Command data Slave unit 10 (32 bits)															
+0E	Command data Slave unit 11 (32 bits)															
+0F	Command data Slave unit 12 (32 bits)															
+10	Command data Slave unit 13 (32 bits)															
+11	Command data Slave unit 14 (32 bits)															
+12	Command data Slave unit 1 (32 bits)															
+13	Command data Slave unit 2 (32 bits)															
+14	Command data Slave unit 3 (32 bits)															
+15	Command data Slave unit 4 (32 bits)															
+16	Command data Slave unit 5 (32 bits)															
+17	Command data Slave unit 6 (32 bits)															
+18	Command data Slave unit 7 (32 bits)															
+19	Command data Slave unit 8 (32 bits)															
+1A	Command data Slave unit 9 (32 bits)															
+1B	Command data Slave unit 10 (32 bits)															
+1C	Command data Slave unit 11 (32 bits)															
+1D	Command data Slave unit 12 (32 bits)															
+1E	Command data Slave unit 13 (32 bits)															
+1F	Command data Slave unit 14 (32 bits)															
+20	Not used															
?	Not used															
+3F	Not used															

<Setting details>

Name	Device No.	Description
Command request sensor	RWw[00]	Specify the controller for sending a command. The command is sent to the controller whose bit is set.
Command code	RWw[01]	Set the command code to be sent to the controller.
Command data	RWw[02] to [1F]	Set the controller set value according to the command to be sent.

1: If it is necessary to use the unused area, always set to "0".

4-3-3 CC-Link mode 3

■ Remote input RX (Mode 3 communication unit → Master station)

This is a read-only register for input from the communication unit to the master station in units of bits.

Values cannot be written to this register.

<Remote input RX>

RX	F	E	D	C	B	A	9	8	7	6	5	4	3	2	1	0	
+00	Sensor response data switching response									Not used						Command response	
	Not used	Error code	Not used	Command	Sensor head value	Calculated value	Normal measured value	Judgment value	Error flag							Send response	
+10	Not used																
+20	Not used	Judgment output 1 (OUT1)															
		Slave unit 14	Slave unit 13	Slave unit 12	Slave unit 11	Slave unit 10	Slave unit 9	Slave unit 8	Slave unit 7	Slave unit 6	Slave unit 5	Slave unit 4	Slave unit 3	Slave unit 2	Slave unit 1	Master unit	
+30	Not used	Judgment output 2 (OUT2)															
		Slave unit 14	Slave unit 13	Slave unit 12	Slave unit 11	Slave unit 10	Slave unit 9	Slave unit 8	Slave unit 7	Slave unit 6	Slave unit 5	Slave unit 4	Slave unit 3	Slave unit 2	Slave unit 1	Master unit	
+40	Not used	Judgment output 3 (OUT3)															
		Slave unit 14	Slave unit 13	Slave unit 12	Slave unit 11	Slave unit 10	Slave unit 9	Slave unit 8	Slave unit 7	Slave unit 6	Slave unit 5	Slave unit 4	Slave unit 3	Slave unit 2	Slave unit 1	Master unit	
+50	Not used	Alarm output															
		Slave unit 14	Slave unit 13	Slave unit 12	Slave unit 11	Slave unit 10	Slave unit 9	Slave unit 8	Slave unit 7	Slave unit 6	Slave unit 5	Slave unit 4	Slave unit 3	Slave unit 2	Slave unit 1	Master unit	
+60	Communication unit	Error output															
		Slave unit 14	Slave unit 13	Slave unit 12	Slave unit 11	Slave unit 10	Slave unit 9	Slave unit 8	Slave unit 7	Slave unit 6	Slave unit 5	Slave unit 4	Slave unit 3	Slave unit 2	Slave unit 1	Master unit	
+70	Not used																
?	Not used																
+1A0	Not used																
+1B0	Not used				Remote ready	Error state	Setting initialization done	Initialization request	Not used								

<Setting details>

	Name	Device No.	Description
Command response	Send response	RX[00]	RY[00]: response bit to a send request. This bit is set when transmission of a command to a controller is completed.
	Error flag	RX[01]	This bit is set when the command response from a controller is an error.
Sensor response data switching response (*1)(*2)	Judgment value (*3)	RX[08]	RY[08]: response bit to a judgment value. This bit is set when judgment value mode is entered.
	Normal measured value (*3)	RX[09]	RY[09]: response bit to a normal measured value. This bit is set when normal measured value mode is entered.
	Calculated value (*3)	RX[0A]	RY[0A]: response bit to a calculated value. This bit is set when calculated value mode is entered.
	Sensor head value (*3)	RX[0B]	RY[0B]: response bit to a sensor head value. This bit is set when sensor head value mode is entered.
	Command	RX[0C]	RY[0C]: response bit to a command. This bit is set when command mode is entered.
	Error code	RX[0E]	RY[0E]: response bit to an error code. This bit is set when error mode is entered.

CC-LINK Network Communication

Name		Device No.	Description
Judgment output 1 (OUT1)		RX[20] to [2E]	Status of output 1 (OUT1) of a connected controller. This bit is set when the output is ON.
Judgment output 2 (OUT2)		RX[30] to [3E]	Status of output 2 (OUT2) of a connected controller. This bit is set when the output is ON.
Judgment output 3 (OUT3)		RX[40] to [4E]	Status of output 3 (OUT3) of a connected controller. This bit is set when the output is ON.
Alarm output (*4)		RX[50] to [5E]	Status of the alarm output of a connected controller. This bit is set when the output is ON.
Error output		RX[60] to [6F]	Status of the error output of a connected controller or the communication unit. When an error occurs, the corresponding bit is set.
System area	Initialization request	RX[1B8]	This bit is set when the product issues an initialization request to the master station. This is not used on the product.
	Setting initialization done	RX[1B9]	RY[1B9]: response bit to an initialize settings request. This bit is set when initialization of the settings is completed.
	Error state	RX[1BA]	When an error occurs, this bit is set. The bit is cleared when the error is cleared.
	Remote ready	RX[1BB]	This bit is set when preparation for communication is completed. The bit is cleared when preparation for communication is not completed or an error has occurred.

*1: RY[08] to [0C], RY[0E]: when all sensor response data switch request bits are cleared, RX[08]: judgment value is set.

*2: RY[08] to [0C], RY[0E]: when multiple bits are set for a sensor response data switch request, a response to the request with the lowest bit number is set.

*3: For information on judgment values, normal measured values, calculated values, and sensor head values, refer to the user's manual of the controller that you use.

*4: Controller-specific function. Refer to the user's manual of the controller that you use.

*5: If it is necessary to use the unused area, always set to "0".

■ Remote register RWr (Mode 3 communication unit → Master station)

This is a read-only register for input from the communication unit to the master station in units of words (16 bits).

Values cannot be written to this register.

<Remote register RWr>

RWr	F	E	D	C	B	A	9	8	7	6	5	4	3	2	1	0
+00	When judgment value / normal measured value / calculated value / sensor head value mode is set → 0x0000 (fixed value)															
	When error mode is set → Communication unit error code (lower word)															
	Not used	Slave unit 14	Slave unit 13	Slave unit 12	Slave unit 11	Slave unit 10	Slave unit 9	Slave unit 8	Slave unit 7	Slave unit 6	Slave unit 5	Slave unit 4	Slave unit 3	Slave unit 2	Slave unit 1	Master unit
+01	When judgment value / normal measured value / calculated value / sensor head value mode is set → 0x0000 (fixed value)															
	When error mode is set → Communication unit error code (upper word)															
	When command mode is set → Command response code															
+02	Sensor response data															
+03	Master unit (32 bits)															
+04	Sensor response data															
+05	Slave unit 1 (32 bits)															
+06	Sensor response data															
+07	Slave unit 2 (32 bits)															
+08	Sensor response data															
+09	Slave unit 3 (32 bits)															
+0A	Sensor response data															
+0B	Slave unit 4 (32 bits)															
+0C	Sensor response data															
+0D	Slave unit 5 (32 bits)															
+0E	Sensor response data															
+0F	Slave unit 6 (32 bits)															
+10	Sensor response data															
+11	Slave unit 7 (32 bits)															
+12	Sensor response data															
+13	Slave unit 8 (32 bits)															
+14	Sensor response data															
+15	Slave unit 9 (32 bits)															
+16	Sensor response data															
+17	Slave unit 10 (32 bits)															
+18	Sensor response data															
+19	Slave unit 11 (32 bits)															
+1A	Sensor response data															
+1B	Slave unit 12 (32 bits)															
+1C	Sensor response data															
+1D	Slave unit 13 (32 bits)															
+1E	Sensor response data															
+1F	Slave unit 14 (32 bits)															
+20	Not used															
?																
+3F																

CC-LINK Network Communication

<Setting details>

Name	Device No.	Description
Command response sensor	RWr[00]	<ul style="list-style-type: none"> ● When judgment value / normal measured value / calculated value / sensor head value mode is set → fixed value 0x0000 is stored ● When command mode is set → The bit corresponding to the controller which returned a response to a command is set. ● When error mode is set → The communication unit error code (lower word) is stored.
Command response code	RWr[01]	<ul style="list-style-type: none"> ● When judgment value / normal measured value / calculated value / sensor head value mode is set → fixed value 0x0000 is stored ● When command mode is set → The command code sent to the controller is stored. ● When error mode is set → The communication unit error code (upper word) is stored.
Sensor response data	RWr[02] to [1F]	<ul style="list-style-type: none"> ● The response data from the controller to which a command or mode was sent is stored.

*1: Values read in unused areas are not defined.

■ Remote output RY (Mode 3 master station → Communication unit)

This is a write-only register for output from the master station to the communication unit in units of bits.

<Remote output RY>

RY	F	E	D	C	B	A	9	8	7	6	5	4	3	2	1	0	
+00	Sensor response data switching request									Not used						Command request	
	Not used	Error code	Not used	Command	Sensor head value	Calculated value	Normal measured value	Judgment value	Write flag							Send request	
+10	Not used																
+20	External input 1 (IN1)																
	Not used	Slave unit 14	Slave unit 13	Slave unit 12	Slave unit 11	Slave unit 10	Slave unit 9	Slave unit 8	Slave unit 7	Slave unit 6	Slave unit 5	Slave unit 4	Slave unit 3	Slave unit 2	Slave unit 1	Master unit	
+30	External input 2 (IN2)																
	Not used	Slave unit 14	Slave unit 13	Slave unit 12	Slave unit 11	Slave unit 10	Slave unit 9	Slave unit 8	Slave unit 7	Slave unit 6	Slave unit 5	Slave unit 4	Slave unit 3	Slave unit 2	Slave unit 1	Master unit	
+40	External input 3 (IN3)																
	Not used	Slave unit 14	Slave unit 13	Slave unit 12	Slave unit 11	Slave unit 10	Slave unit 9	Slave unit 8	Slave unit 7	Slave unit 6	Slave unit 5	Slave unit 4	Slave unit 3	Slave unit 2	Slave unit 1	Master unit	
+50	Not used																
?	Not used																
+1A0	Not used																
+1B0	Not used					Error clear request	Setting initialization request	Initialization done	Not used								

<Setting details>

	Name	Device No.	Description
Command request	Send request	RY[00]	Send command to controller request bit. When this bit is set, a command is sent. To send a subsequent command, clear the bit and then set again.
	Write flag	RY[01]	To execute a read command, clear this bit. To execute a write command, set this bit. RY[00]: Set before a send request.
Sensor response data switching request (*1)(*2)	Judgment value (*3)	RY[08]	Change to judgment value mode. When the bit is set, the mode changes to judgment value mode.
	Normal measured value (*3)	RY[09]	Change to normal measured value mode. When the bit is set, the mode changes to normal measured value mode.
	Calculated value (*3)	RY[0A]	Change to calculated value mode. When the bit is set, the mode changes to calculated value mode.
	Sensor head value (*3)	RY[0B]	Change to sensor head value mode. When the bit is set, the mode changes to sensor head value mode.
	Command	RY[0C]	Change to command mode. When this bit is set, changing to command mode and sending commands is allowed. Set before a command request (RY[00]: send request).
	Error code	RY[0E]	Change to error mode. When this bit is set, the mode changes to error mode.
External input 1 (IN1) (*4)	RY[20] to [2E]	Controls external input 1 on the controller. When this bit is set, external input 1 turns ON.	
External input 2 (IN2) (*4)	RY[30] to [3E]	Controls external input 2 on the controller. When this bit is set, external input 2 turns ON.	
External input 3 (IN3) (*4)	RY[40] to [4E]	Controls external input 3 on the controller. When this bit is set, external input 3 turns ON.	

CC-LINK Network Communication

Name		Description
Initialization done	RY[1B8]	This bit is set as a response when the product issues an initialization request to the master station. This is not used because the product does not issue initialization requests.
Setting initialization request	RY[1B9]	Set this bit to repeat initialization of the product's settings.
Error clear request	RY[1BA]	When an error occurs, this bit is set to clear the error.

- *1: RY[08] to [0C], RY[0E]: when all sensor response data switch request bits are cleared, the RY[08]: judgment value bit is set and the corresponding operation takes place.
- *2: RY[08] to [0C], RY[0E]: when multiple bits are set for a sensor response data switch request, the request with the lowest bit number is given priority.
- *3: For information on judgment values, normal measured values, calculated values, and sensor head values, refer to the user's manual of the controller that you use.
- *4: Operation depends on the controller set value. To use external input, refer to the user's manual of the controller that you use.
- *5: If it is necessary to use the unused area, always set to "0"

■ Remote register RWw (Mode 3 master station → Communication unit)

This is a write-only register for output from the master station to the communication unit in units of words (16 bits).

<Remote register RWw>

RWw	F	E	D	C	B	A	9	8	7	6	5	4	3	2	1	0
+00	Not used	Command request sensor														
		Slave unit 14	Slave unit 13	Slave unit 12	Slave unit 11	Slave unit 10	Slave unit 9	Slave unit 8	Slave unit 7	Slave unit 6	Slave unit 5	Slave unit 4	Slave unit 3	Slave unit 2	Slave unit 1	Master unit
+01	Command code															
+02	Command data															
+03	Master unit (32 bits)															
+04	Command data															
+05	Slave unit 1 (32 bits)															
+06	Command data															
+07	Slave unit 2 (32 bits)															
+08	Command data															
+09	Slave unit 3 (32 bits)															
+0A	Command data															
+0B	Slave unit 4 (32 bits)															
+0C	Command data															
+0D	Slave unit 5 (32 bits)															
+0E	Command data															
+0F	Slave unit 6 (32 bits)															
+10	Command data															
+11	Slave unit 7 (32 bits)															
+12	Command data															
+13	Slave unit 8 (32 bits)															
+14	Command data															
+15	Slave unit 9 (32 bits)															
+16	Command data															
+17	Slave unit 10 (32 bits)															
+18	Command data															
+19	Slave unit 11 (32 bits)															
+1A	Command data															
+1B	Slave unit 12 (32 bits)															
+1C	Command data															
+1D	Slave unit 13 (32 bits)															
+1E	Command data															
+1F	Slave unit 14 (32 bits)															
+20	Not used															
?																
+3F																

<Setting details>

Name	Device No.	Description
Command request sensor	RWw[00]	Specify the controller for sending a command. The command is sent to the controller whose bit is set.
Command code	RWw[01]	Set the command code to be sent to the controller.
Command data	RWw[02] to [1F]	Set the controller set value according to the command to be sent.

*1: If it is necessary to use the unused area, always set to "0".

4-4 Memory map and controller assignments

- This product can be connected to a maximum of 15 controllers (one master controller, 14 slave controllers).
- To enable data communication with connected controllers (master unit and slave units), the memory map contains a communication register for each controller.
- The controllers are assigned to register positions in the memory map based on the position in which each is connected.

! The controllers are automatically assigned in the memory map starting from the master unit and continuing in order from slave unit 1. The order cannot be changed.

Example: Mode 3 remote register RWr

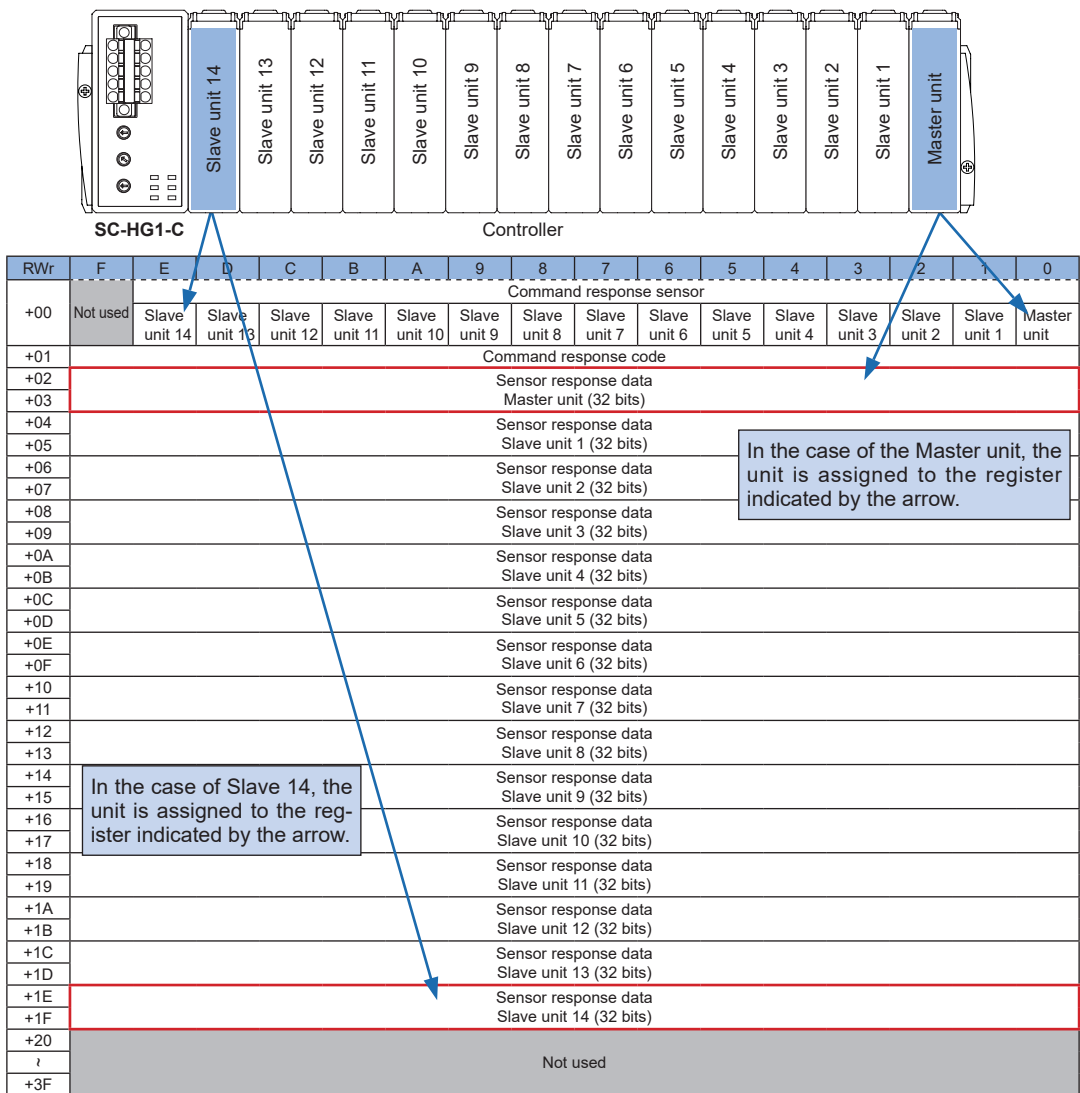

*1: There are other registers in addition to the above example that are assigned in the same way. Refer to the “4-3 Memory map” that corresponds to the mode you are actually using.

4-5 Initial operation after power is turned ON

After the power is turned on, the communication unit cannot start communication until it completes initial transient processing such as initialization.

When the unit is ready for communication after the power is turned on, the RX[7B]: remote ready flag (*1) bit is automatically set.

Check that the RX[7B]: remote ready flag (*1) bit is set before executing communication.

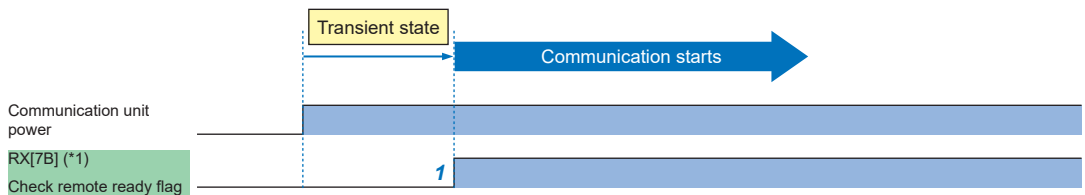

1. When initialization is completed after the power is turned ON, the RX[7B]: remote ready flag (*1) is automatically set.

If the RX[7B]: remote ready flag (*1) is not set after the power is turned ON, startup may have failed.

Check the communication unit connection and settings, and turn on the power again.

*1: The bit position depends on the operation mode.

CC-Link mode 1: RX[7B], CC-Link mode 2: RX[17B], CC-Link mode 3: RX[1BB]

4-6 Judgment output reading

You can get the external output and alarm output of each controller by reading RX[20] to [2E], RX[30] to [3E], RX[40] to [4E], and RX[50] to [5E] in the memory map. These values are always kept updated to the most recent state, so operations such as command setting are not needed. For detailed information on external output and alarm functions, refer to the user's manual of the controller that you use.

<Reference>
Judgment output reading is updated automatically.

Remote output RX (SC-HG1-C → Master)

RX			F	E	D	C	B	A	9	8	7	6	5	4	3	2	1	0
	Sensor Function	Communi- cation unit	Slave unit 14	Slave unit 13	Slave unit 12	Slave unit 11	Slave unit 10	Slave unit 9	Slave unit 8	Slave unit 7	Slave unit 6	Slave unit 5	Slave unit 4	Slave unit 3	Slave unit 2	Slave unit 1	Master unit	
+20	OUT1	0	0	0	0	0	0	0	0	0	0	0	0	0	0	0	0	0
+30	OUT2	0	0	0	0	0	0	0	0	0	0	0	0	0	0	0	0	0
+40	OUT3	0	0	0	0	0	0	0	0	0	0	0	0	0	0	0	0	0
+50	Alarm	0	0	0	0	0	0	0	0	0	0	0	0	0	0	0	0	0

Example: To check the external output signal and alarm function signal of slave unit 2, read RX[22], [32], [42], [52].

Example: To check the external output signal and alarm function signal of the master unit, read RX[20], [30], [40], [50].

4-7 External input

Control of external input from the master unit cable and external input from the **SC-HG1-C** is by OR operation.

Settings from the **SC-HG1-C** and input from external input are by OR operation. When either turns ON, the controller executes ON operation.

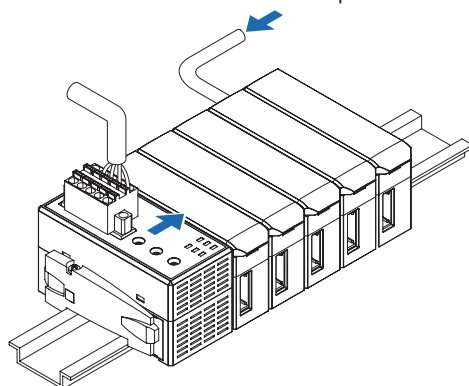

4-8 Continuous reading of measurement data

If you want to continuously read judgment values, normal measured values, calculated values, and sensor head values at once from all connected controllers, you can use a sensor response data switching request to change to each mode and continuously read the values without the need for commands.

Measurement mode	Description
Judgment value	Judgment values are read continuously.
Normal measured value	Normal measured values are read continuously.
Calculated value	Calculated values are read continuously.
Sensor head value	Sensor head values are read continuously.

An example of reading judgment values when a master unit and slave units 1 to 3 are connected is shown below. 1 is only set when the operation mode is CC-Link mode 1.

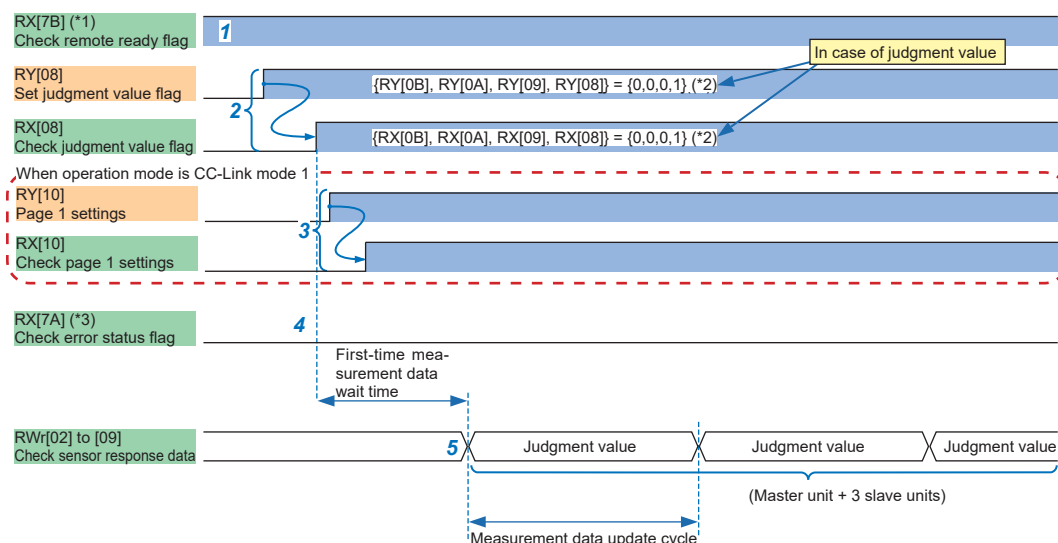

1. Check that RX[7B] (*1): remote ready flag is set.
2. Set the RY[08]: judgment value flag bit. Judgment value reading is requested and the RX[08]: judgment value flag is set. Clear sensor response data switching request flags other than the judgment value flag in advance.
The values will be as shown in the table below depending on the measurement mode that is read.

Measurement mode	RY[0B]	RY[0A]	RY[09]	RY[08]
Judgment value	0	0	0	1
Normal measured value	0	0	1	0
Calculated value	0	1	0	0
Sensor head value	1	0	0	0

3. If the operation mode is CC-Link mode 1, set RY[10]: page 1. Page 1 setting is requested, and RX[10]: page 1 is set. In CC-Link mode 1, always configure the page settings. The page settings of the sensor response data (master unit, slave units 1 to 14) are as shown in the table below.

Sensor response data	RY[10]	RY[11]	RY[12]
Master unit, slave units 1 to 6	1	0	0
Slave units 7 to 13	0	1	0
Slave unit 14	0	0	1

4. Verify that a communication error has not occurred with the RX[7A]: error status flag (*3) cleared. If a communication error has occurred, refer to “**8-2 Communication errors**”.
5. After the initial measurement data wait time, the judgment values are repeatedly stored in an area equivalent to master unit + three slave units of RWr[02] to [09]: sensor response data. The measurement data update cycle is indicated in the table below.

Measurement mode	Update cycle (ms)
Judgment value	1
Normal measured value	15
Calculated value	5
Sensor head value	15

The first time measurement data is saved, a wait time occurs. In addition to the update cycle, the actual update time will increase due to the CC-Link settings (baud rate and number of refresh points) and the device environment.

- *1: The bit position depends on the operation mode.
 CC-Link mode 1: RX[7B], CC-Link mode 2: RX[17B], CC-Link mode 3: RX[1BB]
- *2: If all sensor response data switching requests are cleared, the mode will default to judgment value read mode and RX[08]: judgment value flag will be set.
- *3: The bit position depends on the operation mode.
 CC-Link mode 1: RX[7A], CC-Link mode 2: RX[17A], CC-Link mode 3: RX[1BA]
- *4: If the remote ready flag was cleared, the values may not be correctly acquired. Periodically check if the remote ready flag is set.

4-9 Error mode

To read the error code of an error that recently occurred, use error mode. If multiple errors occurred sequentially, only the error code of the last error is read. Codes can only be read of errors that occurred since the communication unit power was turned on. When the communication unit is restarted, the codes of errors that occurred prior to that time are cleared. For details on errors, refer to “<Table of error codes>” in “8-1 Command error”. An example when a master unit and slave units 1 to 3 are connected is shown below.

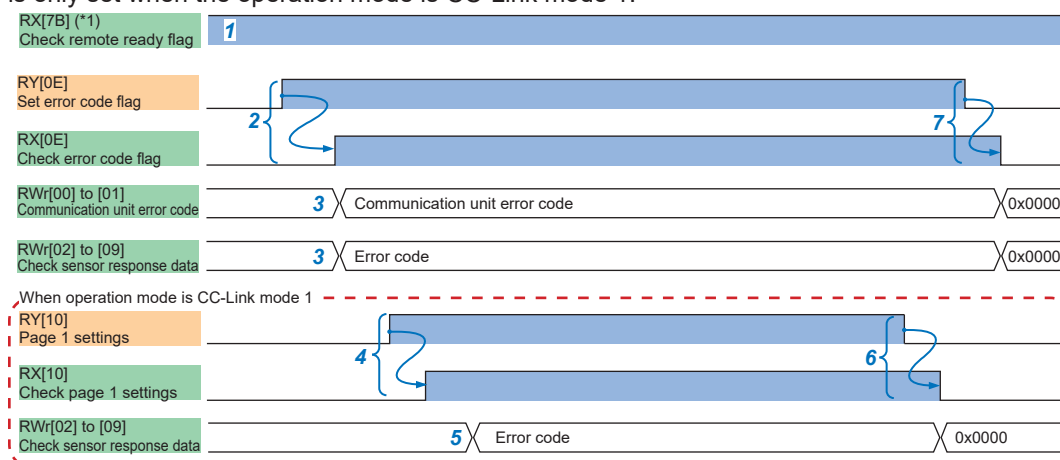

1. Check that RX[7B]: remote ready flag (*1) is set.
2. Set the RY[0E]: error code flag. Verify that the RX[0E]: error code flag is set and error mode has been entered.
3. The RWr[00] to [01] communication error code is stored. If the operation mode is CC-Link mode 2 or CC-Link mode 3, the error codes from the controllers are stored in RWr[02] to [09]: sensor response data.

4. If the operation mode is CC-Link mode 1, set RY[10]: page 1. Page 1 settings are requested, and RX[10]: page 1 is set. In CC-Link mode 1, always configure the page settings. The page settings of the sensor response data (master unit, slave units 1 to 14) are as shown in the table below.

Sensor response data	RY[10]	RY[11]	RY[12]
Master unit, slave units 1 to 6	1	0	0
Slave units 7 to 13	0	1	0
Slave unit 14	0	0	1

5. If the operation mode is CC-Link mode 1, the error codes from the controllers are stored in RWr[02] to [09]: sensor response data.
6. If the operation mode is CC-Link mode 1, clear RY[10]: page 1. Page 1 settings are cleared, and RX[10]: page 1 is cleared. The error codes of RWr[02] to [09]: sensor response data are also cleared.
7. Clear the RY[0E]: error code flag. The communication unit exits error mode, and the RX[0E]: error code flag is cleared.

*1: The bit position depends on the operation mode.
 CC-Link mode 1: RX[7B], CC-Link mode 2: RX[17B], CC-Link mode 3: RX[1BB]

4-10 Commands

4-10-1 HG-S series command list

The following table shows the command parameters that are used to read and write controller settings and statuses and to send operation commands to controllers.
 For details on each item, refer to the “HG-S User’s Manual”.

Attributes (R: Read, W: Write, R/W: Read/Write)

Command	Attribute	Name	Response/Setting parameter
0x0001	R	Status/Error	When status is normal = 0 When error occurs = Error code
0x0002 to 0x0004	-	System reserved	Do not use.
0x0005	W	Controller reset	Reset the controller. (Master unit only)
0x0006	W	Initialization (RESET)	Return the settings to the factory default state. Do not specify "0".
0x0007 to 0x000F	-	System reserved	Do not use.
0x0010	R	Judgment value (JUDGE.V)	Integer indicating minimum resolution units of controller. -1999999 to 1999999
0x0011	R	Normal measured value (NORM.V)	Integer indicating minimum resolution units of controller. -1999999 to 1999999
0x0012	R	Calculated value (CALC)	Integer indicating minimum resolution units of controller. If a calculated value is not set, the judgment value is output. -1999999 to 1999999
0x0013	R	Sensor head measured value (HEAD.V)	Integer indicating minimum resolution units of controller. -1999999 to 1999999
0x0014	R/W	LOW set value (LO.SET)	Integer indicating minimum resolution units of controller. -1999999 to 1999999
0x0015	R/W	HIGH set value (HI.SET)	Integer indicating minimum resolution units of controller. -1999999 to 1999999
0x0016 to 0x0017	-	System reserved	Do not use.
0x0018	R/W	Hysteresis (HYSTER)	Integer indicating minimum resolution units of controller. 0 to 1999999
0x0019	-	System reserved	Do not use.
0x001A	R/W	Output operation (OUTPUT)	0: N.O. 1: N.C.
0x001B	-	System reserved	Do not use.
0x001C	R	Output state	bit0: External output 1 (0 = OFF / 1 = ON) bit1: External output 2 (0 = OFF / 1 = ON) bit2: External output 3 (0 = OFF / 1 = ON) The high bit is "0".
0x001D	R	Input state	bit0: External input 1 (0 = OFF / 1 = ON) bit1: External input 2 (0 = OFF / 1 = ON) bit2: External input 3 (0 = OFF / 1 = ON) The high bit is "0".
0x001E	W	Execute bank load (LOAD)	Bank numbers 1 to 3 are loaded
0x001F	W	Execute bank save (SAVE)	Bank numbers 1 to 3 are saved
0x0020	R/W	Key lock (LOCK)	0: Key lock OFF 1: Key lock ON
0x0021	R/W	Eco mode (ECO)	0: Eco mode OFF 1: Eco mode ON
0x0022	R	Maximum value during P-P measurement	Integer indicating minimum resolution units of controller. If the measurement mode is not P-P or P-P/2, a judgment value is output. -1999999 to 1999999

HG-S Series

	Command	Attribute	Name	Response/Setting parameter
HG-S series	0x0023	R	Minimum value during P-P measurement	Integer indicating minimum resolution units of controller. If the measurement mode is not P-P or P-P/2, a judgment value is output. -1999999 to 1999999
	0x0024 to 0x003F	-	System reserved	Do not use.
	0x0040	R/W	Preset (PRESET)	0: OFF 1: ON
	0x0041	R/W	Preset value (PR. VAL)	Integer indicating minimum resolution units of controller. -1999999 to 1999999
	0x0042	R/W	Preset data selection (PR.OBJ)	0: Normal measured value (NORM.V) 1: Judgment value (JUDGE.V)
	0x0043	R/W	Preset save (PR.SAVE)	0: OFF 1: ON
	0x0044	R/W	Label 1 (LABEL)	Label [1st to 4th character] Part of character code is usable. (Note 1)
	0x0045	R/W	Label 2 (LABEL)	Label [5th to 6th character] Part of character code is usable. (Note 1)
	0x0046	R/W	Response time (SPEED)	0: 3ms 1: 5ms 2: 10ms 3: 100ms 4: 500ms 5: 1000ms
	0x0047	R/W	Measurement direction (DIRECT)	0: Normal display 1: Reverse display
	0x0048	R/W	Alarm delay count (DELAY)	Delay count: 1 to 1000
	0x0049	R/W	Teaching type (TEACH)	0: 1-point teaching 1: 2-point teaching 2: 3-point teaching
	0x004A	R/W	Input all (ALL IN)	0: Individual input 1: Simultaneous input
	0x004B	R/W	External input (EXT.IN)	0: Preset / Reset / Trigger (P/R/T) 1: Bank A / Bank B / Preset (BANK/P) 2: Bank A / Bank B / Reset (BANK/R) 3: Bank A / Bank B / Trigger (BANK/T)
	0x004C	R/W	External output (EXT.OUT)	0: 3-value (3VAL) 1: 2-value (2VAL) 2: Logic (LOGIC) 3: Logic 2 (LOGIC2)
	0x004D	R/W	Analog scaling (ANALOG)	0: Default 1: Free
	0x004E	R/W	Scaling upper limit value (ANA.HI)	Integer indicating minimum resolution units of controller. -1999999 to 1999999
	0x004F	R/W	Scaling lower limit value (ANA.LO)	Integer indicating minimum resolution units of controller. -1999999 to 1999999
	0x0050	R/W	Number of digits displayed (DIGIT)	0: 0.0001 1: 0.001 2: 0.01 3: 0.1
	0x0051	R/W	Calibration selection (CAL.SEL)	0: Default 1: User setting
0x0052	W	1st point calibration execution (CL.SET1)	Acquire the first point measurement value. Specify "0".	
0x0053	R/W	2nd point calibration target value (AJ.VAL2)	Integer indicating minimum resolution units of controller. -1999999 to 1999999	

CC-LINK Network Communication

	Command	Attribute	Name	Response/Setting parameter
HG-S series	0x0054	W	2nd point calibration execution (CL.SET2)	Acquire the 2nd point measurement value. Specify "0".
	0x0055	R/W	1-point teaching tolerance setting (TOL<±>)	Integer indicating minimum resolution units of controller. -1999999 to 1999999
	0x0056	W	1st point teaching execution (SET.1)	Execute 1st point of teaching. Specify "0".
	0x0057	W	2nd point teaching execution (SET.2)	Execute 2nd point of teaching. Specify "0".
	0x0058	W	3rd point teaching execution (SET.3)	Execute 3rd point of teaching. Specify "0".
	0x0059 to 0x005D	-	SOther model command area	Do not use.
	0x005E to 0x009F	-	System reserved	Do not use.
	0x00A0	R	Fault	bit0 : Controller memory function damaged bit1 : Sensor head memory function damaged bit2 : Output section short-circuit error bit3 : Detection circuit damaged bit4 : System error
	0x00A1	-	System reserved	Do not use.
	0x00A2	R	Notification	bit0 : Sensor head unconnected bit2 : Connected unit count check error bit3 : NPN / PNP output type mixture error bit4 : Calculated unlit count error bit5 : Copy executionerror (Slave unit problem) bit10 : Out-of-specification pressure error bit11 : Catch check bit12 : Pressure check
	0x00A3 to 0x00FF	-	System reserved	Do not use.
	0x0100	R/W	Leverage ratio (LEVER)	Leverage ratio ×10 1 to 1000
	0x0101	R/W	Pressure check (PRS.CHK)	0: OFF 1: ON
	0x0102	R/W	Set value for pressure check (PRS.SET)	Integer indicating minimum resolution units of controller. -1999999 to 1999999
	0x0103	R/W	Stuckness check (CAT.CHK)	0: OFF 1: ON
	0x0104	R/W	Hold setting (HOLD)	Set the sum of the values below according to the states of the measurement mode, trigger mode, self trigger edge direction, and self trigger delay settings. <ul style="list-style-type: none"> • Measurement mode (MEAS) 0x0000 = Sample hold 0x1000 = Peak hold 0x2000 = Bottom hold 0x3000 = Peak to peak hold 0x4000 = Peak to peak hold P-P/2 0x5000 = NG hold 0x6000 = Self sample hold 0x7000 = Self peak hold 0x8000 = Self bottom hold • Trigger mode (TRIG) 0x0000 = One-shot 0x1000 = Hold • Self trigger edge direction (SLF.EDG) 0x00 = Rising 0x10 = Falling • Self trigger delay (SLF.DLY) 0x0 = Static width 0x1 = Delay timer

	Command	Attribute	Name	Response/Setting parameter
HG-S series	0x0105	R/W	Self trigger level (SLF.LV)	Integer indicating minimum resolution units of controller. -1999999 to 1999999
	0x0106	R/W	Static width (DLY.WD)	Integer indicating minimum resolution units of controller. -1999999 to 1999999
	0x0107	R/W	Self trigger delay timer (DLY.TIM)	Delay time: 0 to 9999ms
	0x0108	R/W	Calculation mode (MODE) / Calculation application selection (APPLI)	0: No calculation 1: Maximum value (MAX) 2: Minimum value (MIN) 3: Flatness (FLAT) 4: Average value (AVERAG) 5: Standard difference (STAND) 6: Torsion (TORSIN) 7: Curvature (CURVEA) 8: Thickness/Width (THICK)
	0x0109	R/W	Copy select individual (CPY.SEL)	0: Not target / 1: Target For each target, set 0 or 1 for the bit. bit0 : Response time bit1 : Leverage ratio bit2 : Preset save bit3 : Preset data bit4 : Preset value bit5 : Hysteresis bit6 : LOW set value bit7 : HIGH set value bit8 : Measurement direction bit9 : Teaching type bit10 : Number of digits displayed bit11 : Eco mode bit12 : External output bit13 : External input bit14 : Hold setting bit15 : Output operation bit22 : Alarm setting bit23 : Tolerance <±>
	0x010A	W	Copy execution (CPY.EXE)	Execute copying. Specify "0".
	0x010B	R/W	Copy lock (LOCK)	0: Copy lock OFF 1: Copy lock ON
	0x010C	R/W	Bank save selection (BNK.DAT)	0: All 1: HIGH set value, LOW set value 2: HIGH set value, LOW set value, preset value
	0x010D	R/W	Display switching mode	0: Normal measured value 1: Calculated value (during calculation) 2: Label 3: LOW set value 4: HIGH set value 5: Sensor head measured value
	0x010E	R	Total stroke operation log (SUM.REC)	Units of 1 m
	0x010F	R	Maximum peak value (MAX.VAL)	Integer indicating minimum resolution units of controller. -1999999 to 1999999
	0x0110	R	Maximum peak value operation log (MAX.REC)	Units of 1 m
	0x0111	R	Overstroke log (OVR.NUM)	Number of times
0x0112	R/W	Connected unit count check (CON.CHK) (Note 2)	0: OFF 1: ON	

CC-LINK Network Communication

Notes: 1) Usable ASCII character codes (0x20 is a "space")

		1st digit															
		F	E	D	C	B	A	9	8	7	6	5	4	3	2	1	0
2nd digit	0																
	1																
	2	/		-		+	*										
	3		>		<			9	8	7	6	5	4	3	2	1	0
	4	O	N	M	L	K	J	I	H	G	F	E	D	C	B	A	
	5				\		Z	Y	X	W	V	U	T	S	R	Q	P
	6																
	7																

2) This function can be used on **HG-SC** series controllers manufactured in February 2019 and later.

4-10-2 HG-T series command list

The following table shows the command parameters that are used to read and write controller settings and statuses and to send operation commands to controllers.
For details on each item, refer to the “HG-T User’s Manual”.

Attributes (R: Read, W: Write, R/W: Read/Write)

Command	Attribute	Name	Response/Setting parameter
0x0001	R	Status/Error	When status is normal = 0 When error occurs = Error code
0x0002 to 0x0004	-	System reserved	Do not use.
0x0005	W	Controller reset	Reset the controller. (Master unit only)
0x0006	W	Initialization (RESET)	Return the settings to the factory default state. Do not specify "0".
0x0007 to 0x000F	-	System reserved	Do not use.
0x0010	R	Judgment value (JUDGE.V)	Integer indicating minimum resolution units of controller. -1999999 to 1999999
0x0011	R	Normal measured value (NORM.V)	Integer indicating minimum resolution units of controller. -1999999 to 1999999
0x0012	R	Calculated value (CALC)	Integer indicating minimum resolution units of controller. If a calculated value is not set, the judgment value is output. -1999999 to 1999999
0x0013	R	Sensor head measured value (HEAD.V)	Integer indicating minimum resolution units of controller. -1999999 to 1999999
0x0014	R/W	LOW set value (LO.SET)	Integer indicating minimum resolution units of controller. -1999999 to 1999999
0x0015	R/W	HIGH set value (HI.SET)	Integer indicating minimum resolution units of controller. -1999999 to 1999999
0x0016 to 0x0017	-	System reserved	Do not use.
0x0018	R/W	Hysteresis (HYSTER)	Integer indicating minimum resolution units of controller. 0 to 1999999
0x0019	-	System reserved	Do not use.
0x001A	R/W	Output operation (OUTPUT)	0: N.O. 1: N.C.
0x001B	-	System reserved	Do not use.
0x001C	R	Output state	bit0: External output 1 (0 = OFF / 1 = ON) bit1: External output 2 (0 = OFF / 1 = ON) bit2: External output 3 (0 = OFF / 1 = ON) The high bit is "0".
0x001D	R	Input state	bit0: External input 1 (0 = OFF / 1 = ON) bit1: External input 2 (0 = OFF / 1 = ON) bit2: External input 3 (0 = OFF / 1 = ON) The high bit is "0".
0x001E	W	Execute bank load (LOAD)	Bank numbers 1 to 3 are loaded
0x001F	W	Execute bank save (SAVE)	Bank numbers 1 to 3 are saved
0x0020	R/W	Key lock (LOCK)	0: Key lock OFF 1: Key lock ON
0x0021	R/W	Eco mode (ECO)	0: Eco mode OFF 1: Eco mode ON

CC-LINK Network Communication

	Command	Attribute	Name	Response/Setting parameter
HG-T series	0x0022	R	Maximum value during P-P measurement	Integer indicating minimum resolution units of controller. If the measurement mode is not P-P, a judgment value is output. -1999999 to 1999999
	0x0023	R	Minimum value during P-P measurement	Integer indicating minimum resolution units of controller. If the measurement mode is not P-P, a judgment value is output. -1999999 to 1999999
	0x0024 to 0x003F	-	System reserved	Do not use.
	0x0040	R/W	Preset (PRESET)	0: OFF 1: ON
	0x0041	R/W	Preset value (PR. VAL)	Integer indicating minimum resolution units of controller. -1999999 to 1999999
	0x0042	R/W	Preset data selection (PR.OBJ)	0: Normal measured value (NORM.V) 1: Judgment value (JUDGE.V)
	0x0043	R/W	Preset save (PR.SAVE)	0: OFF 1: ON
	0x0044	R/W	Label 1 (LABEL)	Label [1st to 4th character] Part of character code is usable. (Note 1)
	0x0045	R/W	Label 2 (LABEL)	Label [5th to 6th character] Part of character code is usable. (Note 1)
	0x0046	R/W	Average count (SPEED)	0: 1 time 1: 2 times 2: 4 times 3: 8 times 4: 16 times 5: 32 times 6: 64 times 7: 128 times 8: 256 times 9: 512 times 10: 1024 times
	0x0047	R/W	Measurement direction (DIRECT)	0: TOP 1: BOTTOM
	0x0048	R/W	Alarm delay count (DELAY)	Delay count: 1 to 1000
	0x0049	R/W	Teaching type (TEACH)	0: 1-point teaching 1: 2-point teaching 2: 3-point teaching
	0x004A	R/W	Input all (ALL IN)	0: Individual input 1: Simultaneous input
	0x004B	R/W	External input (EXT.IN)	0: Preset / Reset / Trigger (P/R/T) 1: Bank A / Bank B / Preset (BANK/P) 2: Bank A / Bank B / Reset (BANK/R) 3: Bank A / Bank B / Trigger (BANK/T) 4: Preset / Trigger / Laser emission stop (P/T/L)
	0x004C	R/W	External output (EXT.OUT)	0: 3-value (3VAL) 1: 2-value (2VAL) 2: Logic (LOGIC) 3: Logic 2 (LOGIC2) 4: Hold (HOLD)
	0x004D	R/W	Analog scaling (ANALOG)	0: Default 1: Free
0x004E	R/W	Scaling upper limit value (ANA.HI)	Integer indicating minimum resolution units of controller. -1999999 to 1999999	

	Command	Attribute	Name	Response/Setting parameter
HG-T Series	0x004F	R/W	Scaling lower limit value (ANA.LO)	Integer indicating minimum resolution units of controller. -1999999 to 1999999
	0x0050	R/W	Number of digits displayed (DIGIT)	1: 0.001 2: 0.01 3: 0.1
	0x0051	R/W	Calibration selection (CAL.SEL)	0: Default 1: User setting 2: Calibration start
	0x0052	W	1st point calibration execution (CL.SET1)	Acquire the first point measurement value. Specify "0".
	0x0053	R/W	2nd point calibration target value (AJ.VAL2)	Integer indicating minimum resolution units of controller. -1999999 to 1999999
	0x0054	W	2nd point calibration execution (CL.SET2)	Acquire the 2nd point measurement value. Specify "0".
	0x0055	R/W	1-point teaching tolerance setting (TOL<±>)	Integer indicating minimum resolution units of controller. -1999999 to 1999999
	0x0056	W	1st point teaching execution (SET.1)	Execute 1st point of teaching. Specify "0".
	0x0057	W	2nd point teaching execution (SET.2)	Execute 2nd point of teaching. Specify "0".
	0x0058	W	3rd point teaching execution (SET.3)	Execute 3rd point of teaching. Specify "0".
	0x0059	R/W	Sampling cycle (SAMPLI)	0: Standard sampling (NORMAL) 1: High-speed sampling (HI-SPD)
	0x005A	R/W	Analog output selection (A/O.SEL)	0: Voltage output 1: Current output
	0x005B	R/W	External output delay timer selection (OUT.DLY)	0: OFF 1: On delay 2: Off delay 3: Single shot delay
	0x005C	R/W	External output delay timer time (OD.TIME)	1 to 9999ms
	0x005D	R/W	1st point calibration target value (AJ.VAL1)	Integer indicating minimum resolution units of controller -1999999 to 1999999
	0x005E to 0x009F	–	System reserved	Do not use.
	0x00A0	R	Fault	bit0 : Controller memory function damaged bit1 : Sensor head memory function damaged bit2 : Output section short-circuit error bit3 : Detection circuit damaged bit4 : System error
	0x00A1	R	Caution	bit0 : Controller cumulative run time limit exceeded bit1 : Sensor head cumulative run time limit exceeded bit2 : Controller memory saving count limit exceeded bit3 : Sensor head memory saving count limit exceeded
	0x00A2	R	Notification	bit0 : Sensor head unconnected bit1 : Connected sensor head incompatible bit2 : Connected unit count check error bit3 : NPN / PNP output type mixture error bit4 : Calculated unit count error bit5 : Copy executionerror (Slave unit problem) bit16 : Detection capability limit(obtained edge information) bit17 : Ambient light bit18 : Stain check bit20 : Reverse insertion check
	0x00A3 to 0x00FF	–	System reserved	Do not use.

CC-LINK Network Communication

Command	Attribute	Name	Response/Setting parameter
0x0100 to 0x0112	-	Other model command area	Do not use.
0x0113 to 0x02FF	-	System reserved	Do not use.
0x0300	R/W	Operation mode (OP.MODE)	0: Auto edge detection mode 1: Edge detection mode 2: External form/width detection mode 3: Inside diameter/gap detection mode 5: Center position detection mode 8: User assigned edge detection mode
0x0301	-	System reserved	Do not use.
0x0302	R/W	edge1 (EDGE1)	0: TOP 1~10: 1st to 10th counting from TOP 255: BOTTOM
0x0303	R/W	edgw2 (EDGE2)	0: TOP 1~10: 1st to 10th counting from TOP 255: BOTTOM
0x0304	R/W	Sensitivity setting (SEN.ADJ)	0: DEFAULT 1: USER
0x0305	R/W	Judgment level (JDG.LVL)	10 to 90
0x0306	R/W	Judgment filter (JDG.FIL)	3 to 50
0x0307	R/W	Reference waveform save (BW.SAVE)	0: OFF 1: ON
0x0308	R/W	Interference prevention function (INTF.PR)	0: OFF 1: ON
0x0309	R/W	Alarm state selection (ALM.CND)	0: HOLD (hold previous value) 1: ALARM (alarm output)
0x030A to 0x030B	-	System reserved	Do not use.
0x030C	R/W	Stain check (STA.CHK)	0: Stain check OFF (OFF) 1: Low sensitivity setting ON (LOW) 2: High sensitivity setting ON (HIGH) 3: User setting ON (USER)
0x030D	R/W	Stain threshold (STA.THR)	50 to 95
0x030E	R/W	Hold setting (HOLD)	Set the sum of the values below according to the states of the measurement mode and trigger mode settings. • Measurement mode (MEAS) 0x0000 = Sample hold 0x1000 = Peak hold 0x2000 = Bottom hold 0x3000 = Peak to peak hold 0x4000 = Peak to peak hold P-P/2 0x5000 = NG hold 0x0900 = Tab Cancellation • Trigger mode (TRIG) 0x0000 = One-shot 0x1000 = Hold
0x030F to 0x0311	-	System reserved	Do not use.
0x0312	R/W	Tab threshold (TB.THRS)	1000~200000
0x0313	R/W	Tab counts (TB.CNT)	5~23
0x0314 to 0x0315	-	System reserved	Do not use.
0x0316	R/W	Calculation mode (MODE) / Calculation application selection (APPLI)	0: No calculation 1: Maximum value (MAX) 2: Minimum value (MIN) 4: Average value (AVERAG) 5: Standard difference (STAND) 8: Thickness/Width (THICK)

HG-T Series

Command	Attribute	Name	Response/Setting parameter	
HG-T Series	0x0317	R/W	Copy select individual (CPY.SEL)	0 = Not target / 1 = Target For each target, set the bit to 0 or 1. Bit 0: Operation mode selection Bit 1: Measurement direction Bit 2: HIGH set value Bit 3: LOW set value Bit 4: Hysteresis Bit 5: Teaching type Bit 6: Tolerance setting Bit 7: Preset value Bit 8: Preset data selection Bit 9: Preset save Bit 10: Reference waveform save Bit 11: Average count Bit 12: Output pattern Bit 13: Analog output selection Bit 14: Hold setting Bit 15: External input Bit 16: External output Bit 17: External output delay timer selection Bit 18: Number of digits displayed Bit 19: Eco mode Bit 20: Alarm Bit 21: Key lock setting selection Bit 22: Reverse of measured value
	0x0318	-	System reserved	Do not use.
	0x0319	W	Copy execution (CPY.EXE)	Execute copying. Specify "0".
	0x031A	R/W	Copy lock (LOCK)	0: Copy lock OFF 1: Copy lock ON
	0x031B	R/W	Bank save selection (BNK.DAT)	0: All 1: HIGH set value, LOW set value 2: HIGH set value, LOW set value, preset value
	0x031C	R/W	Display switching mode	0: Normal measured value 1: Calculated value (during calculation) 2: Label 3: LOW set value 4: HIGH set value 5: Sensor head measured value 6: Work insertion direction (Note 2)
	0x031D	R	Controller cumulative run time (RUN.TIM)	Units of 1 hour
	0x031E	R	Sensor head cumulative run time (HD.TIME)	Units of 1 hour
	0x031F to 0x0322	-	System reserved	Do not use.
	0x0323	R/W	Connected unit count check (CON.CHK)	0: OFF 1: ON
	0x0324	R/W	Key lock (KEYLOC)	0: MANUAL 1: AUTO
	0x0325	R/W	Reverse insertion check (DIR.CHK)	0: OFF 1: ON

CC-LINK Network Communication

Command	Attribute	Name	Response/Setting parameter																																					
HG-T Series	0x0326	R	Work insertion direction state (Note 2)	<ul style="list-style-type: none"> • Auto edge detection mode 0: TOP 1: BOTTOM 2: Indeterminate • Edge detection mode, center position detection mode 0: TOP 1: BOTTOM 2: Indeterminate • External form / width detection mode, inside diameter / gap detection mode, User assigned edge detection mode 2: Indeterminate 																																				
	0x0327 to 0x035F	-	System reserved	Do not use.																																				
	0x0360	W	Beam axis adjustment mode start	Start beam axis adjustment. Specify "0". Always send during measurement.																																				
	0x0361	R	Beam axis adjustment status	bit0 to bit12: Reserved																																				
				<table border="1"> <thead> <tr> <th>bit15</th> <th>bit14</th> <th>bit13</th> <th>Beam axis state</th> </tr> </thead> <tbody> <tr> <td>0</td> <td>0</td> <td>0</td> <td>Immediately after beam axis adjustment starts</td> </tr> <tr> <td>0</td> <td>0</td> <td>1</td> <td>Beam axis aligned state</td> </tr> <tr> <td>0</td> <td>1</td> <td>0</td> <td>Receiver has shifted toward TOP side (emitter has shifted toward BOTTOM side)</td> </tr> <tr> <td>0</td> <td>1</td> <td>1</td> <td>Receiver has shifted toward BOTTOM side (emitter has shifted toward TOP side)</td> </tr> <tr> <td>1</td> <td>0</td> <td>0</td> <td>Beam axis is completely out of position (fully blocked state)</td> </tr> <tr> <td>1</td> <td>0</td> <td>1</td> <td>The light intensity is too much</td> </tr> <tr> <td>1</td> <td>1</td> <td>0</td> <td>The light intensity is too little</td> </tr> <tr> <td>1</td> <td>1</td> <td>1</td> <td>Objects intercepting light or stains (adhering substances) exist inside measurement area</td> </tr> </tbody> </table>	bit15	bit14	bit13	Beam axis state	0	0	0	Immediately after beam axis adjustment starts	0	0	1	Beam axis aligned state	0	1	0	Receiver has shifted toward TOP side (emitter has shifted toward BOTTOM side)	0	1	1	Receiver has shifted toward BOTTOM side (emitter has shifted toward TOP side)	1	0	0	Beam axis is completely out of position (fully blocked state)	1	0	1	The light intensity is too much	1	1	0	The light intensity is too little	1	1	1	Objects intercepting light or stains (adhering substances) exist inside measurement area
				bit15	bit14	bit13	Beam axis state																																	
				0	0	0	Immediately after beam axis adjustment starts																																	
				0	0	1	Beam axis aligned state																																	
				0	1	0	Receiver has shifted toward TOP side (emitter has shifted toward BOTTOM side)																																	
				0	1	1	Receiver has shifted toward BOTTOM side (emitter has shifted toward TOP side)																																	
1				0	0	Beam axis is completely out of position (fully blocked state)																																		
1	0	1	The light intensity is too much																																					
1	1	0	The light intensity is too little																																					
1	1	1	Objects intercepting light or stains (adhering substances) exist inside measurement area																																					
0x0362	W	Reference waveform registration execution	Execute reference waveform registration. Specify "0". Always send with beam axis in aligned state																																					
0x0363	R	Reference waveform registration status	0: Registration completed 1: Registration failed 2: Registering																																					
0x0364	W	Beam axis adjustment end	End beam axis adjustment. Specify "0".																																					
0x0365 to 0x036F	-	System reserved	Do not use.																																					

	Command	Attribute	Name	Response/Setting parameter
HG-T Series	0x0370	R	Waveform read setting (Note 3)	bit0 to bit7 : Select a waveform type. 0x00 : Reference waveform 0x10 : Waveform during beam axis adjustment 0x11 : Measured waveform bit8 : Reserved bit9 : Status 0: Waveform information has not been saved (For example, immediately after the unit starts up, operation mode is changed, or measured values are reset) 1: Waveform information has been saved bit10 to bit15: Reserved
		W		bit0 to bit7 : Select a waveform type. 0x00 : Reference waveform 0x10 : Received light waveform during beam axis adjustment 0x11 : Measured waveform bit8 to bit15 : Reserved Always set "0x01".
	0x0371	R	Waveform read data 1	Obtains four bytes of received light waveform data ("Received light intensity 0" to "Received light intensity 3")
	0x0372	R	Waveform read data 2	Obtains four bytes of received light waveform data ("Received light intensity 4" to "Received light intensity 7")
	0x0373	R	Waveform read data 3	Obtains four bytes of received light waveform data ("Received light intensity 8" to "Received light intensity 11")
	0x0374	R	Waveform read data 4	Obtains four bytes of received light waveform data ("Received light intensity 12" to "Received light intensity 15")
	0x0375	R	Waveform read data 5	Obtains four bytes of received light waveform data ("Received light intensity 16" to "Received light intensity 19")
	0x0376	R	Waveform read data 6	Obtains four bytes of received light waveform data ("Received light intensity 20" to "Received light intensity 23")
	0x0377	R	Waveform read data 7	Obtains four bytes of received light waveform data ("Received light intensity 24" to "Received light intensity 27")
	0x0378	R	Waveform read data 8	Obtains four bytes of received light waveform data ("Received light intensity 28" to "Received light intensity 31")
	0x0379	R	Waveform read data 9	Obtains four bytes of received light waveform data ("Received light intensity 32" to "Received light intensity 35")
	0x037A	R	Waveform read data 10	Obtains four bytes of received light waveform data ("Received light intensity 36" to "Received light intensity 39")
	0x037B	R	Waveform read data 11	Obtains four bytes of received light waveform data ("Received light intensity 40" to "Received light intensity 43")

CC-LINK Network Communication

	Command	Attribute	Name	Response/Setting parameter
HG-T Series	0x037C	R	Waveform read data 12	Obtains four bytes of received light waveform data ("Received light intensity 44" to "Received light intensity 47")
	0x037D	R	Waveform read data 13	Obtains four bytes of received light waveform data ("Received light intensity 48" to "Received light intensity 51")
	0x037E	R	Waveform read data 14	Obtains four bytes of received light waveform data ("Received light intensity 52" to "Received light intensity 55")
	0x037F	R	Waveform read data 15	Obtains four bytes of received light waveform data ("Received light intensity 56" to "Received light intensity 59")
	0x0380	R	Waveform read data 16	Obtains four bytes of received light waveform data ("Received light intensity 60" to "Received light intensity 63")
	0x0381	R	Waveform read data 17	Obtains four bytes of received light waveform data ("Received light intensity 64" to "Received light intensity 67")
	0x0382	R	Waveform read data 18	Obtains four bytes of received light waveform data ("Received light intensity 68" to "Received light intensity 71")
	0x0383	R	Waveform read data 19	Obtains four bytes of received light waveform data ("Received light intensity 72" to "Received light intensity 75")
	0x0384	R	Waveform read data 20	Obtains four bytes of received light waveform data ("Received light intensity 76" to "Received light intensity 79")
	0x0385	R	Waveform read data 21	Obtains four bytes of received light waveform data ("Received light intensity 80" to "Received light intensity 83")
	0x0386	R	Waveform read data 22	Obtains four bytes of received light waveform data ("Received light intensity 84" to "Received light intensity 87")
	0x0387	R	Waveform read data 23	Obtains four bytes of received light waveform data ("Received light intensity 88" to "Received light intensity 91")
	0x0388	R	Waveform read data 24	Obtains four bytes of received light waveform data ("Received light intensity 92" to "Received light intensity 95")
	0x0389	R	Waveform read data 25	Obtains four bytes of received light waveform data ("Received light intensity 96" to "Received light intensity 99")
	0x038A	R	Waveform read data 26	Obtains four bytes of received light waveform data ("Received light intensity 100" to "Received light intensity 103")
	0x038B	R	Waveform read data 27	Obtains four bytes of received light waveform data ("Received light intensity 104" to "Received light intensity 107")
	0x038C	R	Waveform read data 28	Obtains four bytes of received light waveform data ("Received light intensity 108" to "Received light intensity 111")
0x038D	R	Waveform read data 29	Obtains four bytes of received light waveform data ("Received light intensity 112" to "Received light intensity 115")	
0x038E	R	Waveform read data 30	Obtains four bytes of received light waveform data ("Received light intensity 116" to "Received light intensity 119")	

	Command	Attribute	Name	Response/Setting parameter
HG-T Series	0x038F	R	Waveform read data 31	Obtains four bytes of received light waveform data ("Received light intensity 120" to "Received light intensity 123")
	0x0390	R	Waveform read data 32	Obtains four bytes of received light waveform data ("Received light intensity 124" to "Received light intensity 127")
	0x0391	R	Waveform read data 33	Obtains four bytes of received light waveform data ("Received light intensity 128" to "Received light intensity 131")
	0x0392	R	Waveform read data 34	Obtains four bytes of received light waveform data ("Received light intensity 132" to "Received light intensity 135")
	0x0393	R	Waveform read data 35	Obtains four bytes of received light waveform data ("Received light intensity 136" to "Received light intensity 139")
	0x0394	R	Waveform read data 36	Obtains four bytes of received light waveform data ("Received light intensity 140" to "Received light intensity 143")
	0x0395	R	Waveform read data 37	Obtains four bytes of received light waveform data ("Received light intensity 144" to "Received light intensity 147")
	0x0396	R	Waveform read data 38	Obtains four bytes of received light waveform data ("Received light intensity 148" to "Received light intensity 151")
	0x0397	R	Waveform read data 39	Obtains four bytes of received light waveform data ("Received light intensity 152" to "Received light intensity 155")
	0x0398	R	Waveform read data 40	Obtains four bytes of received light waveform data ("Received light intensity 156" to "Received light intensity 159")
	0x0399	R	Waveform read data 41	Obtains four bytes of received light waveform data ("Received light intensity 160" to "Received light intensity 163")
	0x039A	R	Waveform read data 42	Obtains four bytes of received light waveform data ("Received light intensity 164" to "Received light intensity 167")
	0x039B	R	Waveform read data 43	Obtains four bytes of received light waveform data ("Received light intensity 168" to "Received light intensity 171")
	0x039C	R	Waveform read data 44	Obtains four bytes of received light waveform data ("Received light intensity 172" to "Received light intensity 175")
	0x039D	R	Waveform read data 45	Obtains four bytes of received light waveform data ("Received light intensity 176" to "Received light intensity 179")
	0x039E	R	Waveform read data 46	Obtains four bytes of received light waveform data ("Received light intensity 180" to "Received light intensity 183")
	0x039F	R	Waveform read data 47	Obtains four bytes of received light waveform data ("Received light intensity 184" to "Received light intensity 187")
	0x03A0	R	Waveform read data 48	Obtains four bytes of received light waveform data ("Received light intensity 188" to "Received light intensity 191")
0x03A1	R	Waveform read data 49	Obtains four bytes of received light waveform data ("Received light intensity 192" to "Received light intensity 195")	

CC-LINK Network Communication

	Command	Attribute	Name	Response/Setting parameter
HG-T Series	0x03A2	R	Waveform read data 50	Obtains four bytes of received light waveform data ("Received light intensity 196" to "Received light intensity 199")
	0x03A3	R	Waveform read data 51	Obtains four bytes of received light waveform data ("Received light intensity 200" to "Received light intensity 203")
	0x03A4	R	Waveform read data 52	Obtains four bytes of received light waveform data ("Received light intensity 204" to "Received light intensity 207")
	0x03A5	R	Waveform read data 53	Obtains four bytes of received light waveform data ("Received light intensity 208" to "Received light intensity 211")
	0x03A6	R	Waveform read data 54	Obtains four bytes of received light waveform data ("Received light intensity 212" to "Received light intensity 215")
	0x03A7	R	Waveform read data 55	Obtains four bytes of received light waveform data ("Received light intensity 216" to "Received light intensity 219")
	0x03A8	R	Waveform read data 56	Obtains four bytes of received light waveform data ("Received light intensity 220" to "Received light intensity 223")
	0x03A9	R	Waveform read data 57	Obtains four bytes of received light waveform data ("Received light intensity 224" to "Received light intensity 227")
	0x03AA	R	Waveform read data 58	Obtains four bytes of received light waveform data ("Received light intensity 228" to "Received light intensity 231")
	0x03AB	R	Waveform read data 59	Obtains four bytes of received light waveform data ("Received light intensity 232" to "Received light intensity 235")
	0x03AC	R	Waveform read data 60	Obtains four bytes of received light waveform data ("Received light intensity 236" to "Received light intensity 239")
	0x03AD	R	Waveform read data 61	Obtains four bytes of received light waveform data ("Received light intensity 240" to "Received light intensity 243")
	0x03AE	R	Waveform read data 62	Obtains four bytes of received light waveform data ("Received light intensity 244" to "Received light intensity 247")
	0x03AF	R	Waveform read data 63	Obtains four bytes of received light waveform data ("Received light intensity 248" to "Received light intensity 251")
	0x03B0	R	Waveform read data 64	Obtains four bytes of received light waveform data ("Received light intensity 252" to "Received light intensity 255")
0x03B1	R	Edge information at the time of waveform reading	<p>The information to be read differs according to the waveform type selected in "Waveform read setting". See below.</p> <ul style="list-style-type: none"> • When "Reference waveform" (0x00) is selected → "4-11-3 Reading reference waveforms" • When "Waveform during beam axis adjustment" (0x10) is selected → "4-12 Registering the reference waveform (For the HG-T only)" • When "Measured waveform" (0x11) is selected → "4-11-2 Reading measured waveforms" 	
0x03B2	R	Measured value at the time of waveform reading (HEAD.V)	Integer indicating minimum resolution units of controller. -1999999 to 1999999	

Command	Attribute	Name	Response/Setting parameter												
0x03B3	R	Edge position at the time of waveform reading	<ul style="list-style-type: none"> Edge position 0 bit8 to bit15: 0x00 to 0xFF Edge position 1 bit0 to bit7: 0x00 to 0xFF 												
0x03B4 to 0x03BB	-	System reserved	Do not use.												
0x03BC	R	Edge data read setting	bit0 to bit8 : Reserved bit9 : Status 0: Edge data has not been read (For example, immediately after the unit starts up, operation mode is changed, or measured values are reset) 1: Edge data has been read bit10 to bit15: Reserved												
	W		bit0 to bit7 : Reserved Always write "0x00". bit 8 to : Reserved bit15 : Always write "0x01".												
0x03BD	R	Edge information at the time of edge data reading	bit0 to bit12: Reserved bits 13 and 14: Edge information 2												
			<table border="1"> <thead> <tr> <th>bit14</th> <th>bit13</th> <th>Description</th> </tr> </thead> <tbody> <tr> <td>0</td> <td>0</td> <td>Both edges disabled (When the beam axis state is "in-determinate", "fully blocked state", or "measurement alarm 1")</td> </tr> <tr> <td>0</td> <td>1</td> <td>Only one edge enabled</td> </tr> <tr> <td>1</td> <td>0</td> <td>Both edges enabled</td> </tr> </tbody> </table>	bit14	bit13	Description	0	0	Both edges disabled (When the beam axis state is "in-determinate", "fully blocked state", or "measurement alarm 1")	0	1	Only one edge enabled	1	0	Both edges enabled
			bit14	bit13	Description										
			0	0	Both edges disabled (When the beam axis state is "in-determinate", "fully blocked state", or "measurement alarm 1")										
0	1	Only one edge enabled													
1	0	Both edges enabled													
bit 15: Edge information 1															
<table border="1"> <thead> <tr> <th>bit15</th> <th>Description</th> </tr> </thead> <tbody> <tr> <td>0</td> <td>Falling edge</td> </tr> <tr> <td>1</td> <td>Rising edge</td> </tr> </tbody> </table>	bit15	Description	0	Falling edge	1	Rising edge									
bit15	Description														
0	Falling edge														
1	Rising edge														
0x03BE	R	Measured value at the time of edge data reading (HEAD.V)	Integer indicating minimum resolution units of controller. -1999999 to 1999999												
0x03BF	R	Edge position at the time of edge data reading	<ul style="list-style-type: none"> Edge position 0 bit8 to bit15: 0x00 to 0xFF Edge position 1 bit0 to bit7: 0x00 to 0xFF 												
0x03EF	R/W	Reverse of measured value (REVERS)	Enabled/Disabled the reverse of measured value function. 0 : Reverse of measured value disabled 1 : Reverse of measured value enabled												

Notes: 1) Usable ASCII character codes (0x20 is a "space")

		1st digit															
		F	E	D	C	B	A	9	8	7	6	5	4	3	2	1	0
2nd digit	0																
	1																
	2	/		-		+	*										
	3		>		<			9	8	7	6	5	4	3	2	1	0
	4	O	N	M	L	K	J	I	H	G	F	E	D	C	B	A	
	5				\		Z	Y	X	W	V	U	T	S	R	Q	P
	6																
	7																

- 2) In auto edge detection mode, the workpiece insertion direction state is output.
In edge detection mode or center position detection mode, the measurement direction setting is output.
- 3) For details on how to read waveforms, refer to "4 -11 Reading received light waveforms (For the HG-T only)".

4-10-3 Command sending procedure

Use this procedure to select a destination controller and send a command once only to that controller.

There is a slight difference in the operation of read commands and write commands.

<Read command sending procedure>

This section explains the procedure for using the command transmission function to read controller information.

The example of sending the get judgment value command “0x0010” (Read) to a master unit and slave units 1 to 3 is shown below. 1 is only set when the operation mode is CC-Link mode 1.

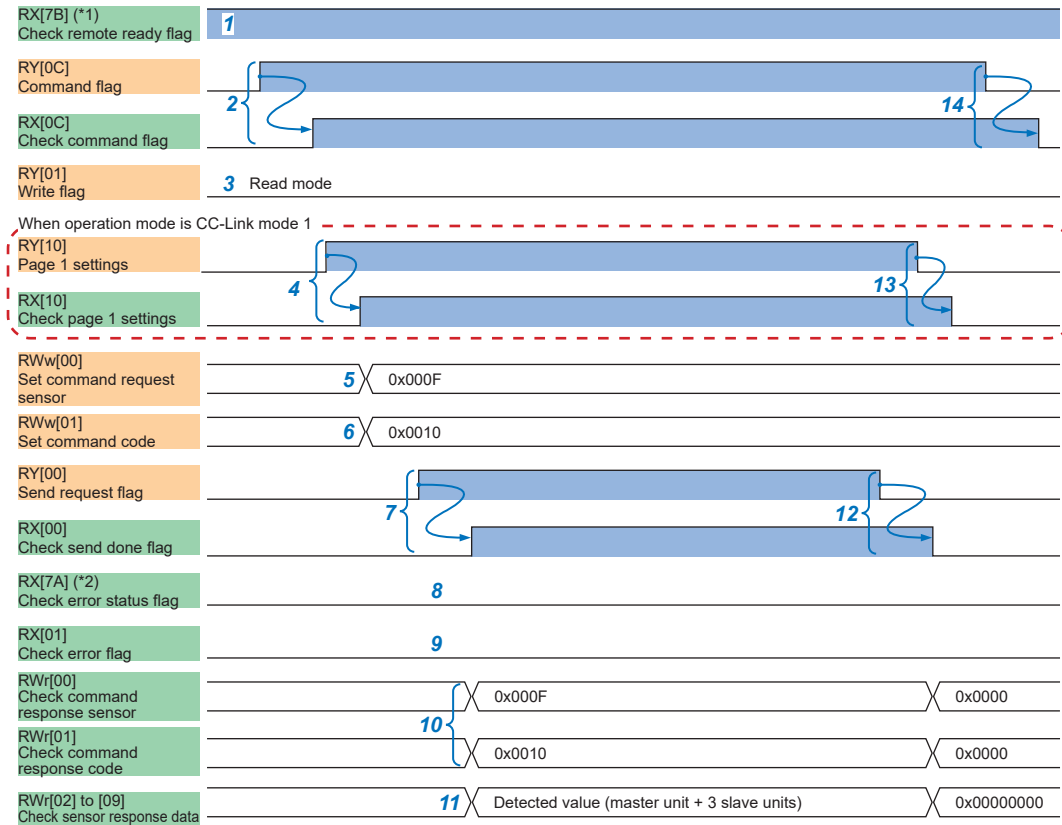

1. Check that RX[7B]: remote ready flag (*1) is set.
2. Set the RY[0C]: command flag. This puts the communication unit in command mode, and the RX[0C]: command flag is set. Clear sensor response data switching request flags other than the command flag in advance.
3. Clear the RY[01]: write flag and activate Read mode.

4. If the operation mode is CC-Link mode 1, set RY[10]: page 1. Page 1 setting is requested, and RX[10]: page 1 is set. In CC-Link mode 1, always configure the page settings. The page settings of the sensor response data (master unit, slave units 1 to 14) are as shown in the table below.

Sensor response data	RY[10]	RY[11]	RY[12]
Master unit, slave units 1 to 6	1	0	0
Slave units 7 to 13	0	1	0
Slave unit 14	0	0	1

5. Specify the controller to which the command will be sent with RWw[00]: command request sensor. When the operation mode is CC-Link mode 1, take care not to specify a command request sensor outside the specified page setting range.
6. Set the command code to be sent to RWw[01].
7. Set RY[00]: send request flag and send the command. When command transmission is completed, RX[00]: send done flag is set. Verify that RX[00]: send done flag is set, and then proceed with the steps below.
8. Verify that a communication error has not occurred with the RX[7A]: error status flag (*2) cleared. If a communication error has occurred, refer to “**8-2 Communication errors**”.
9. Verify that a command error has not occurred with the RX[01]: error flag cleared. If a command error has occurred, refer to “**8-1 Command error**”.
10. The value specified in step 5 (master unit, slave unit 1, slave unit 2, slave unit 3: 0x000F) is set in RWr[00]: command response sensor. The command code sent to RWr[01] is stored.
11. The read command response data are stored in an area equivalent to master unit + three slave units of RWr[02] to [09]: sensor response data.
12. Clear the RY[00]: send request flag. The communication unit ends command transmission, and the RX[00]: send done flag is cleared.
13. If the operation mode is CC-Link mode 1, clear RY[10]: page 1. Page 1 settings are cleared, and RX[10]: page 1 is cleared.
14. Clear the RY[0C]: command flag. The communication unit exits command mode, and RX[0C]: command flag is cleared.

- *1: The bit position depends on the operation mode.
 CC-Link mode 1: RX[7B], CC-Link mode 2: RX[17B], CC-Link mode 3: RX[1BB]
- *2: The bit position depends on the operation mode.
 CC-Link mode 1: RX[7A], CC-Link mode 2: RX[17A], CC-Link mode 3: RX[1BA]

CC-LINK Network Communication

<Write command sending procedure>

This section explains the procedure for using the command transmission function to write setting information to a controller.

The example of sending the LOW set value command "0x0014" (write) to a master unit and slave units 1 to 3 is used.

 is only set when the operation mode is CC-Link mode 1.

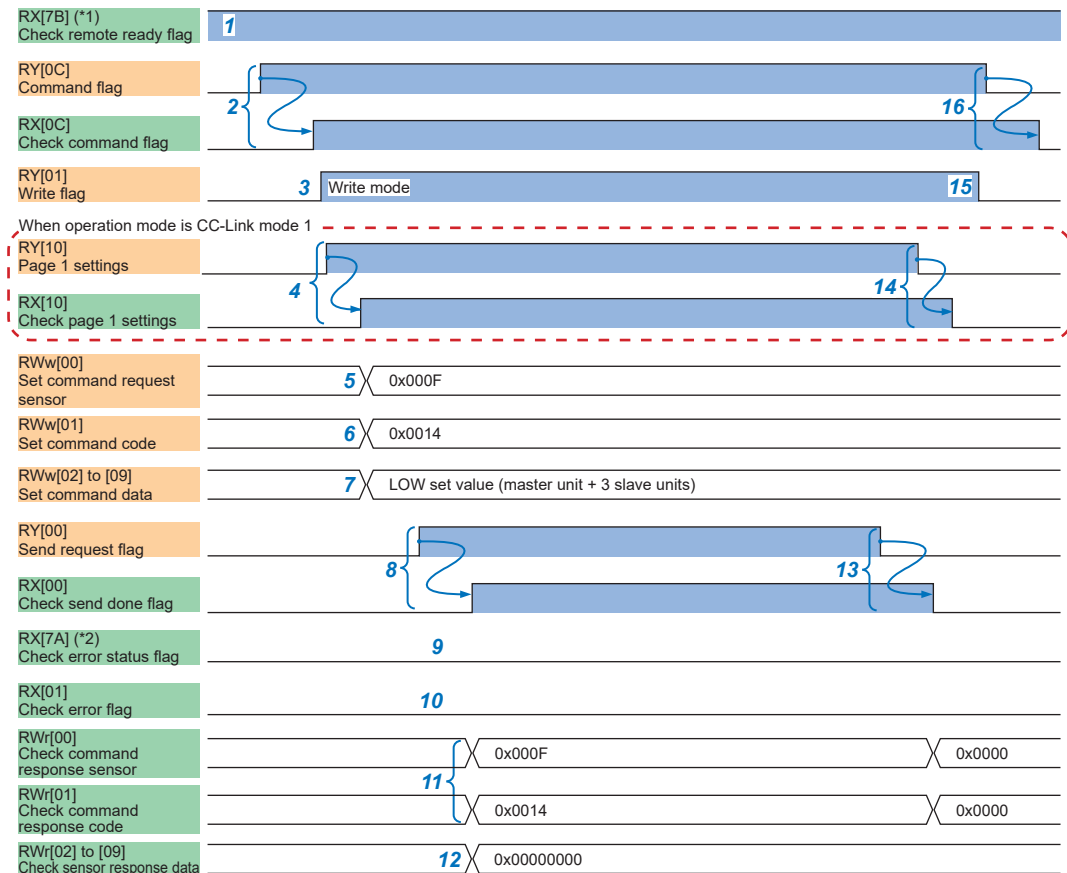

1. Check that RX[7B]: remote ready flag (*1) is set.
2. Set the RY[0C]: command flag. This puts the communication unit in command mode, and the RX[0C]: command flag is set. Clear sensor response data switching request flags other than the command flag in advance.
3. Set the RY[01]: write flag and activate Write mode.

4. If the operation mode is CC-Link mode 1, set RY[10]: page 1. Page 1 setting is requested, and RX[10]: page 1 is set. In CC-Link mode 1, always configure the page settings. The page settings of the sensor response data (master unit, slave units 1 to 14) are as shown in the table below.

Sensor response data	RY[10]	RY[11]	RY[12]
Master unit, slave units 1 to 6	1	0	0
Slave units 7 to 13	0	1	0
Slave unit 14	0	0	1

5. Specify the controller to which the command will be sent with RWw[00]: command request sensor. When the operation mode is CC-Link mode 1, take care not to specify a command request sensor outside the specified page setting range.
6. Set the command code to be sent to RWw[01].
7. Set the command data to be sent to RWw[02] to [09].
8. Set RY[00]: send request flag and send the command. When command transmission is completed, RX[00]: send done flag is set. Verify that RX[00]: send done flag is set, and then proceed with the steps below.
9. Verify that a communication error has not occurred with the RX[7A]: error status flag (*2) cleared. If a communication error has occurred, refer to “**8-2 Communication errors**”.
10. Verify that a command error has not occurred with the RX[01]: error flag cleared. If a command error has occurred, refer to “**8-1 Command error**”.
11. The value specified in step 5 (master unit, slave unit 1, slave unit 2, slave unit 3: 0x000F) is set in RWr[00]: command response sensor. The command code sent to RWr[01] is stored.
12. The RWr sensor response data is “0”.
13. Clear RY[00]: send request flag. The communication unit ends command transmission, and the RX[00]: send done flag is cleared.
14. If the operation mode is CC-Link mode 1, clear RY[10]: page 1. Page 1 settings are cleared, and RX[10]: page 1 is cleared.
15. Clear RY[01]: write flag.
16. Clear RY[0C]: command flag. The communication unit exits command mode, and RX[0C]: command flag is cleared.

- *1: The bit position depends on the operation mode.
 CC-Link mode 1: RX[7B], CC-Link mode 2: RX[17B], CC-Link mode 3: RX[1BB]
- *2: The bit position depends on the operation mode.
 CC-Link mode 1: RX[7A], CC-Link mode 2: RX[17A], CC-Link mode 3: RX[1BA]

4 -11 Reading received light waveforms (For the HG-T only)

When reading received light waveforms, select measured waveforms, reference waveforms, or waveforms during beam axis adjustment (Note 1), so that you can read waveform data and other information.

Note: For details on waveforms during beam axis adjustment, refer to “4-12 Registering the reference waveform (For the HG-T only)”.

4-11-1 Format of received light waveform

Reading received light waveforms makes it possible to obtain simplified received light waveforms that represent the maximum received light width (CMOS cell) of the receiver by 256 areas (0 to 255) and the received light intensity by 256 gradations (0 to 255).

• **Measurement start point and measurement end point**

Measurement start points and measurement end points can be obtained only in reference waveform acquisition mode. Obtaining the measurement start point and measurement end point makes it possible to know the range that is used for measurement within the simplified received light waveform.

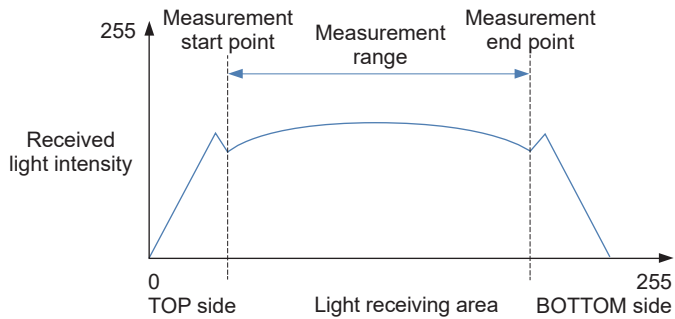

• **Edge information and edge position**

Edge information can be obtained as information indicating a rising edge or falling edge at each edge position (edge information 1) and effective edge mode information (edge information 2). Edge positions are points on the borderline between light interception and light entry within the received light intensity waveform when a measured object is inserted. The edge position on the top side is 0.

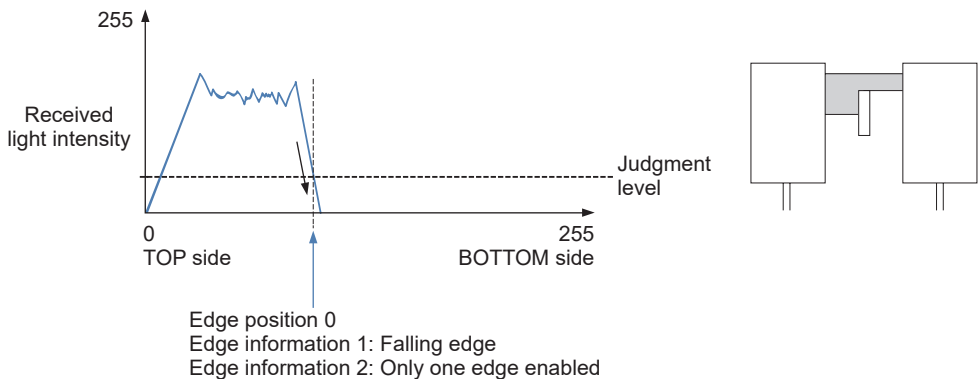

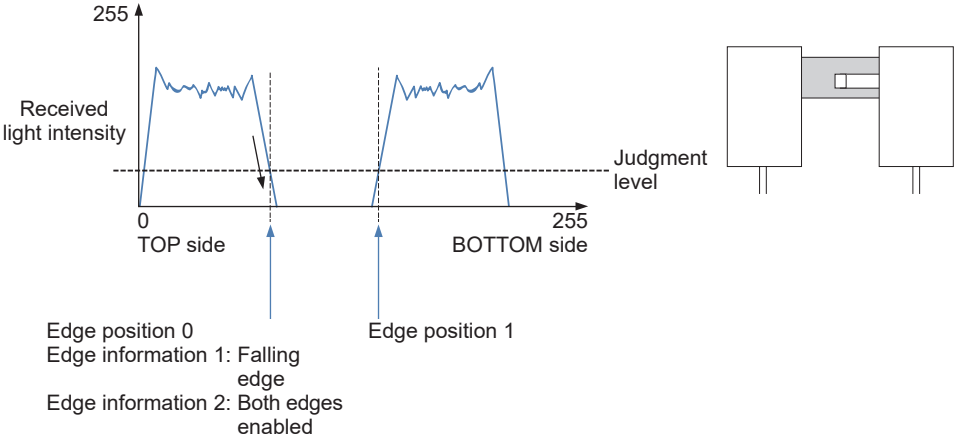
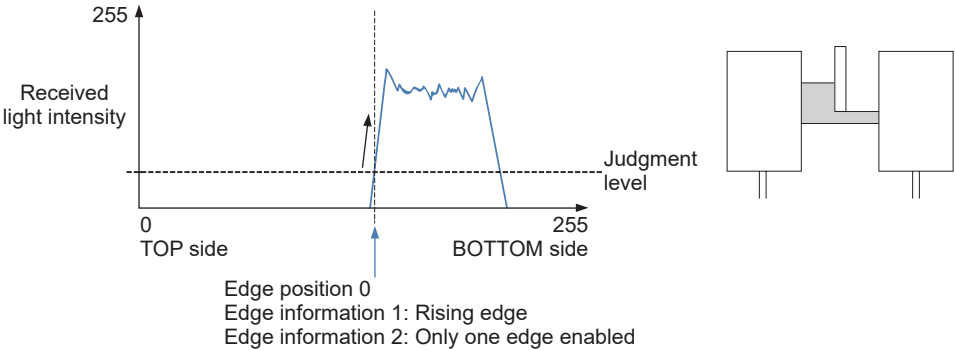

4-11-2 Reading measured waveforms

The following procedure is used to read waveforms.

■ Flowchart of measured waveform reading

1. "Waveform read setting" (WRITE)

The command selects a waveform type (measured waveform).



2. "Waveform read setting" (READ)

The command saves the current waveform information into the controller.



3. "Waveform read data" (READ)

The command reads waveform data.



4. "Measured value at the time of waveform reading [HEAD.V]" (READ)

The command reads the measured value that is associated with the waveform when the waveform is saved.

5. "Edge information at the time of waveform reading" (READ)

The command reads the edge information that is associated with the waveform when the waveform is saved.

6. "Edge position at the time of waveform reading"(READ)

The command reads the edge position associated with the waveform that is saved.

■ Examples of sent commands

1. Send the “Waveform read setting” command (WRITE) to set the waveform type.
(Command code: 0x0370)

Send this command only for the first time after starting the communication unit or when switching the type of the waveform to be read.

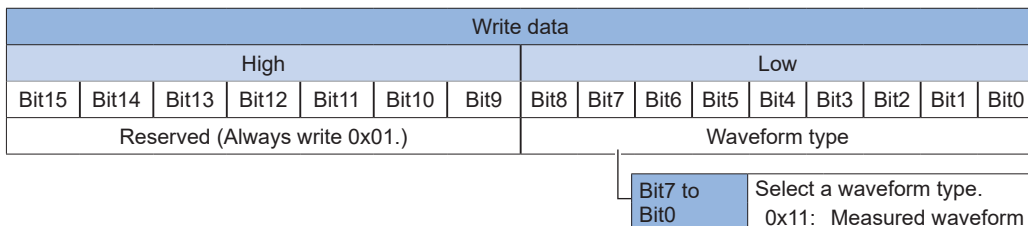

2. Send the “Waveform read setting” command (READ). (Command code: 0x0370)

If the response is normal, the following response data will be returned.

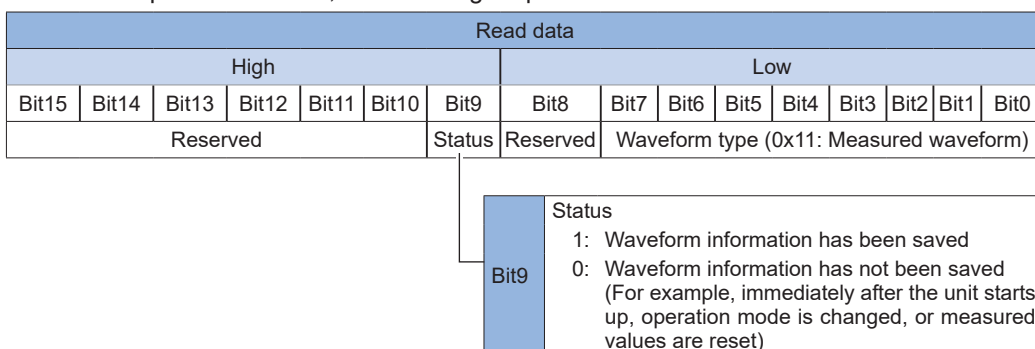

The waveform information that is obtained when this command is sent will be saved in the controller.

3. Send the “Waveform read data” command (READ). (Command code: 0x0371 to 0x03B0)

The “Waveform read data” command can obtain four bytes of received light data by using a single address. Measured waveform data can be obtained by sending command codes from 0x0371 through to 0x03B0 in this order and then concatenating the data obtained. If the response is normal, the following response data will be returned.

<Example: When the command code is 0x0371>

Read data			
Received light intensity [0] 0x00 to 0xFF	Received light intensity [1] 0x00 to 0xFF	Received light intensity [2] 0x00 to 0xFF	Received light intensity [3] 0x00 to 0xFF

- Reading waveforms continuously

When continuously reading waveforms with the same waveform ID, repeatedly send the commands described in 2. and subsequent steps. The update interval of compressed waveform information is 64 ms. Leave an interval of at least 1 ms when sending each command.

4. To read the measured value associated with the saved waveform, send the “Measured value at the time of waveform reading [HEAD.V]” command (READ). (Command code: 0x03B2)

If the response is normal, the following response data will be returned.

Read data			
Measured value: Bit 7 to Bit 0	Measured value: Bit 15 to Bit 8	Measured value: Bit 23 to Bit 16	Measured value: Bit 31 to Bit 24
-1999999 to 1999999			

Note: If it is unnecessary to obtain the measured value associated with the waveform, there is no need to send the command.

5. To read the edge information associated with the saved waveform, send the “Edge information at the time of waveform reading” command (READ). (Command code: 0x03B1)

If the response is normal, the following response data will be returned.

Read data															
High								Low							
Bit15	Bit14	Bit13	Bit12	Bit11	Bit10	Bit9	Bit8	Bit7	Bit6	Bit5	Bit4	Bit3	Bit2	Bit1	Bit0
Edge information 1	Edge information 2	Reserved						Reserved							

Item	Bit15	Description
Edge information 1	0	Falling edge
	1	Rising edge
Information about whether edge position 0 is a rising edge or falling edge when viewed from the TOP side		

Item	Bit14	Bit13	Set value	Description
Edge information 2	0	0	Both edges disabled ("Indeterminate", "fully blocked state", or "measurement alarm 1")	Information about whether edge positions are disabled or enabled. If edge positions are enabled, this item also identifies whether information for only edge position 0 is enabled or information for both edge position 0 and edge position 1 is enabled.
	0	1	Only one edge enabled	
	1	0	Both edges enabled	

Note: If it is unnecessary to obtain the edge information associated with the waveform, there is no need to send the command.

6. To read the edge position associated with the saved waveform, send the “Edge position at the time of waveform reading” command (READ). (Command code: 0x03B3)

If the response is normal, the following response data will be returned.

Read data															
High								Low							
Bit15	Bit14	Bit13	Bit12	Bit11	Bit10	Bit9	Bit8	Bit7	Bit6	Bit5	Bit4	Bit3	Bit2	Bit1	Bit0
Edge position 0 (0x00 to 0xFF)								Edge position 1 (0x00 to 0xFF) (Note 1)							

Notes: 1) If edge information 2 is set to “Only one edge enabled”, edge position 1 will be indeterminate.
 2) If it is unnecessary to obtain the edge position associated with the waveform, there is no need to

send the command.

4-11-3 Reading reference waveforms

The following procedure is used to read waveforms.

■ Flowchart of reference waveform reading

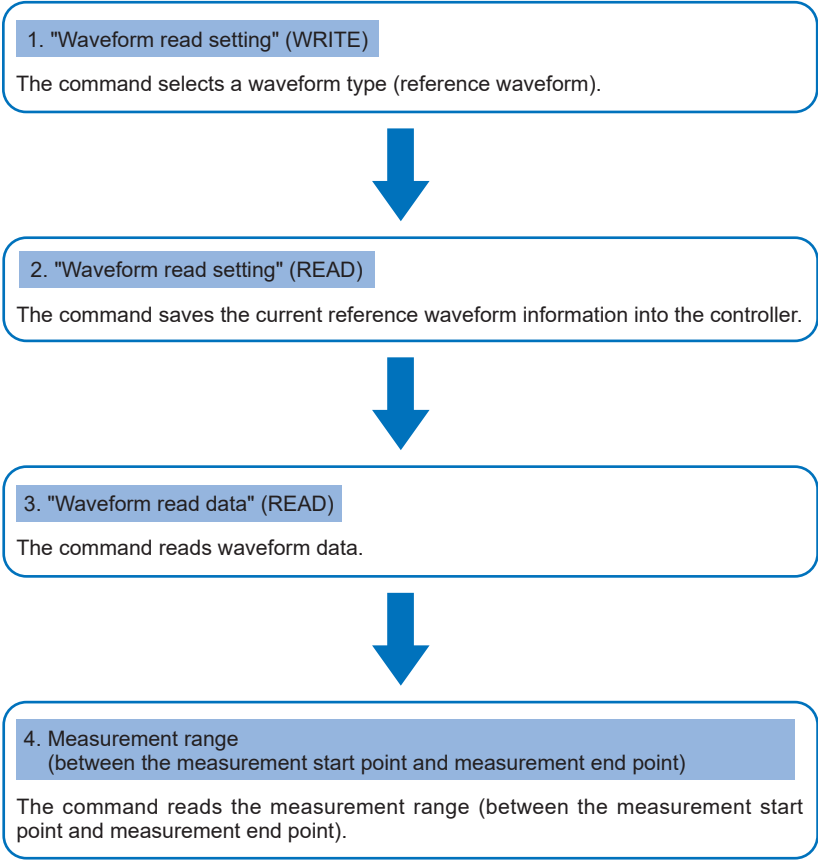

■ Examples of sent commands

1. Send the “Waveform read setting” command (WRITE) to set the waveform type.
(Command code: 0x0370)

Send this command only for the first time after starting the communication unit or when switching the type of the waveform to be read.

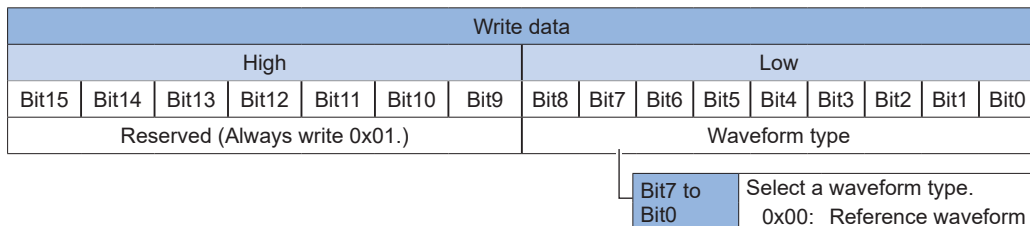

2. Send the “Waveform read setting” command (READ). (Command code: 0x0370)

If the response is normal, the following response data will be returned.

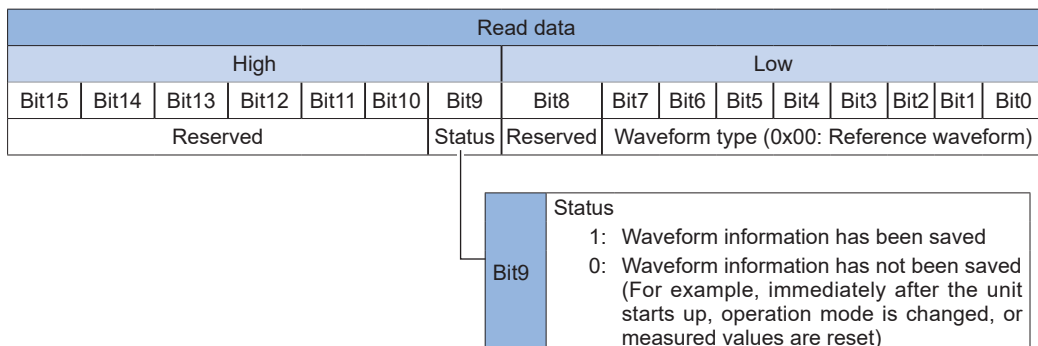

3. Send the “Waveform read data” command (READ). (Command code: 0x0371 to 0x03B0)

The “Waveform read data” command can obtain four bytes of received light data by using a single address. Reference waveform data can be obtained by sending command codes from 0x0371 through to 0x03B0 in this order and then concatenating the data obtained.

If the response is normal, the following response data will be returned.

<Example: When the command code is 0x0371>

Read data			
Received light intensity [0] 0x00 to 0xFF	Received light intensity [1] 0x00 to 0xFF	Received light intensity [2] 0x00 to 0xFF	Received light intensity [3] 0x00 to 0xFF

- 4.** To obtain the measurement range (between the measurement start point and measurement end point), send the “Measurement range acquisition” command (READ) (command code: 0x03B1).

If the response is normal, the following response data will be returned.

Read data	
Measurement end point	Measurement start point
0x00 to 0xFF	0x00 to 0xFF

Note: If it is unnecessary to obtain the measurement range, there is no need to send the command.

4-12 Registering the reference waveform (For the HG-T only)

The following flowchart shows the procedure for reading and registering waveforms to register the reference waveform.

To register the reference waveform, you must invoke beam axis adjustment mode.

■ Flowchart of reference waveform registration

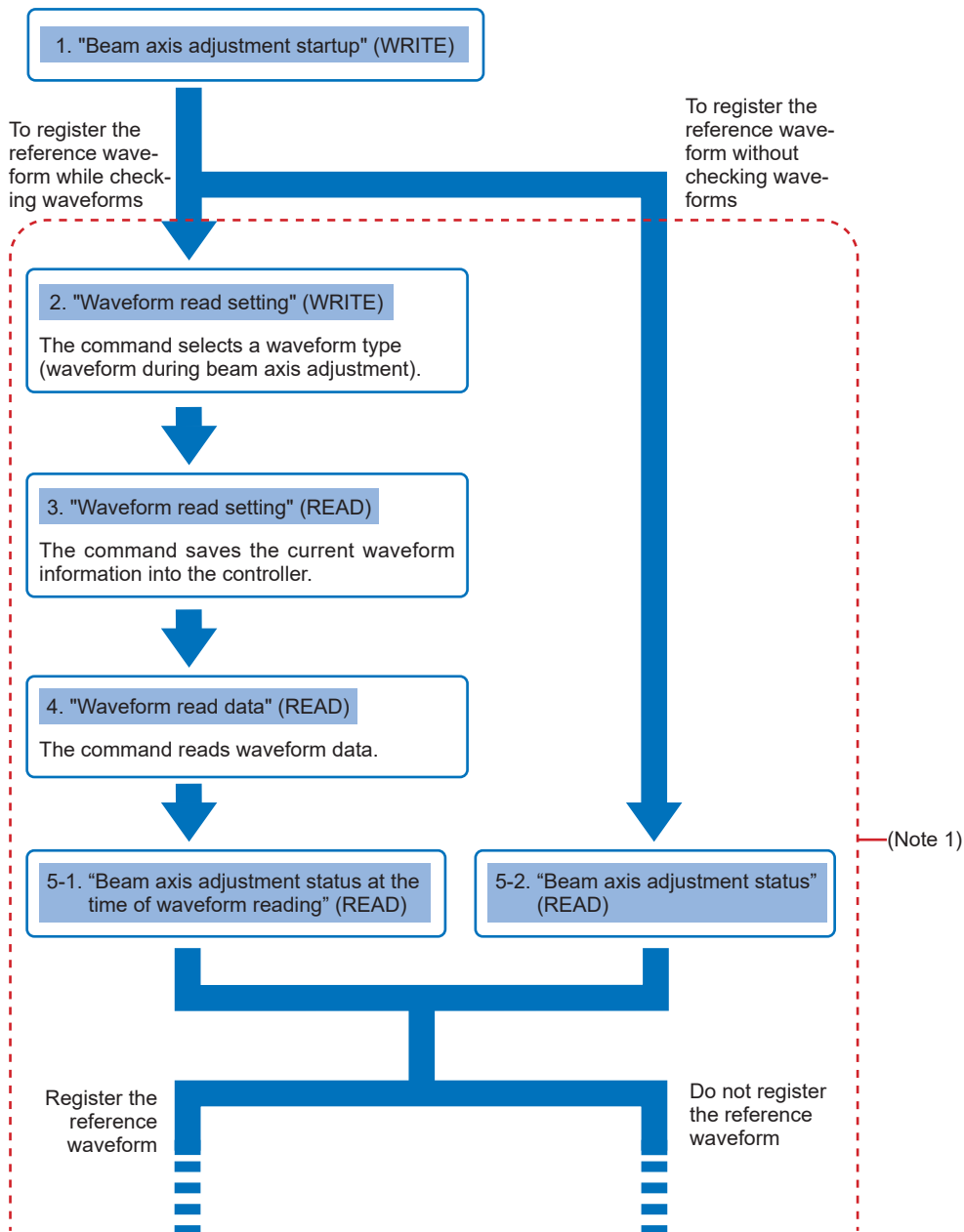

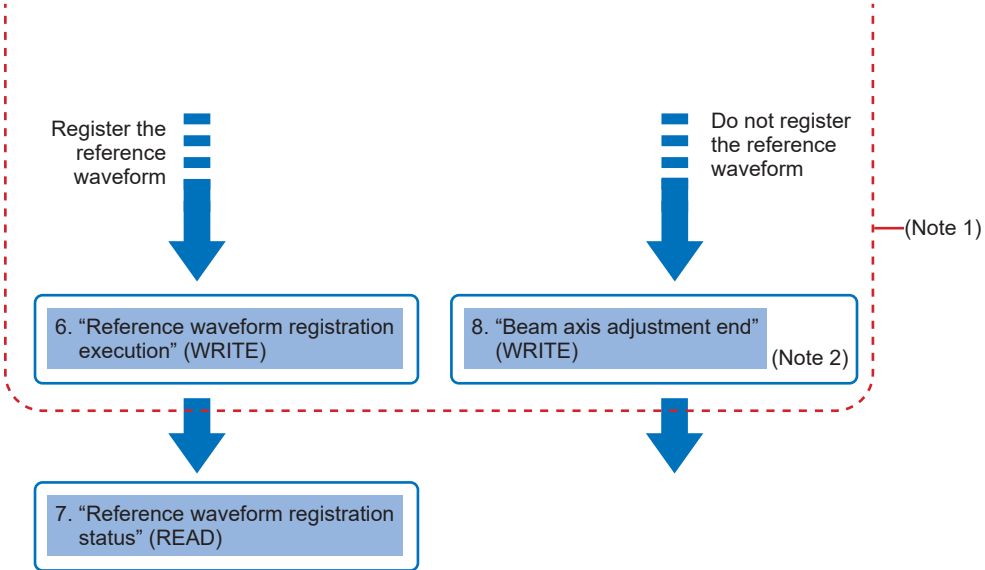

Notes: 1) The inside of the frame indicated by the red dotted lines represents beam axis adjustment mode.
2) Beam axis adjustment mode can be terminated at any procedure step by using "8. Beam axis adjustment end (WRITE)" command.

CC-LINK Network Communication

■ Examples of sent commands

1. Send the “Beam axis adjustment startup” command (WRITE). (Command code: 0x0360)
Write data “0”.

To adjust the beam axis without checking waveforms, go to Step 5-2.

2. Send the “Waveform read setting” command (WRITE) to set the waveform type.
(Command code: 0x0370)
Send this command only for the first time after starting the communication unit or when switching the type of the waveform to be read.

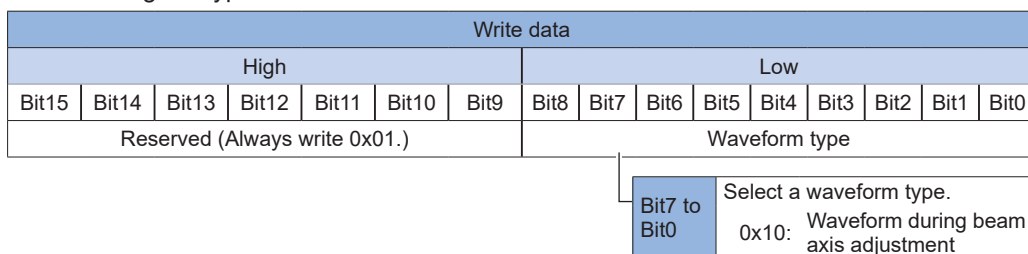

3. Send the “Waveform read setting” command (READ). (Command code: 0x0370)
The waveform information that is obtained when this command is sent will be saved in the controller.

If the response is normal, the following response data will be returned.

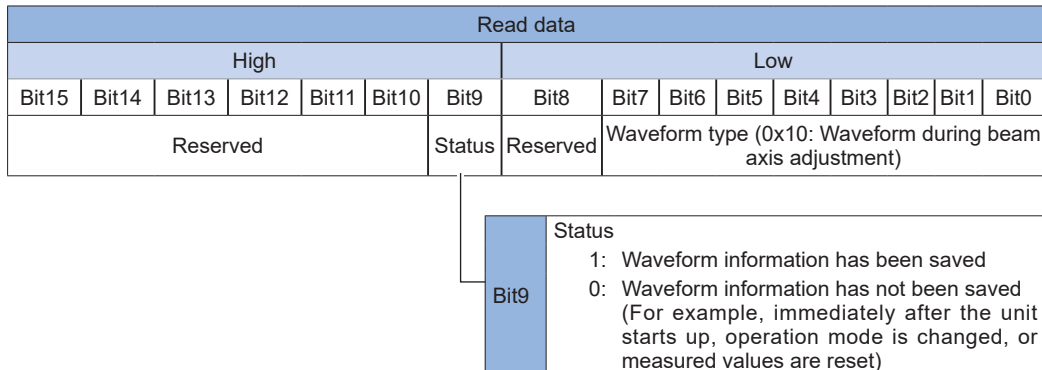

4. Send the “Waveform read data” command (READ). (Command code: 0x0371 to 0x03B0)

The “Waveform read data” command can obtain four bytes of received light data by using a single address. Measured waveform data can be obtained by sending command codes from 0x0371 through to 0x03B0 in this order and then concatenating the data obtained.

If the response is normal, the following response data will be returned.

<Example: When the command code is 0x0371>

Read data			
Received light intensity [0] 0x00 to 0xFF	Received light intensity [1] 0x00 to 0xFF	Received light intensity [2] 0x00 to 0xFF	Received light intensity [3] 0x00 to 0xFF

- Reading waveforms continuously
When continuously reading waveforms with the same waveform ID, repeatedly send the commands described in 3. and subsequent steps. The update interval of compressed waveform information is 64 ms. Leave an interval of at least 1 ms when sending each command.

5. To check the beam axis status, execute either of the following commands.

5-1. To check the beam axis adjustment status after reading the waveform, send the “Beam axis adjustment status at the time of waveform reading” command (READ). (Command code: 0x03B1)

5-2. To check the beam axis adjustment status without reading waveforms, send the “Beam axis adjustment status” command (READ). (Command code: 0x0361)

If the response is normal, the following response data will be returned.

Read data															
High								Low							
Bit15	Bit14	Bit13	Bit12	Bit11	Bit10	Bit9	Bit8	Bit7	Bit6	Bit5	Bit4	Bit3	Bit2	Bit1	Bit0
Beam axis state			Reserved												

Details of beam axis status

Bit15	Bit14	Bit13	Beam axis state
0	0	0	Immediately after beam axis adjustment starts
0	0	1	Beam axis aligned state
0	1	0	Receiver has shifted toward TOP side (emitter has shifted toward BOTTOM side)
0	1	1	Receiver has shifted toward BOTTOM side
1	0	0	Beam axis is completely out of alignment (fully blocked state)
1	0	1	The light intensity is too much
1	1	0	The light intensity has decreased
1	1	1	Objects intercepting light or stains (adhering substances) exist inside measurement area

6. To register the reference waveform after checking the beam axis adjustment status, send the “Reference waveform registration execution” command (WRITE). (Command code: 0x0362)
Write data “0”.

- Notes:
- 1) To save data in EEPROM when registering the reference waveform with the command, set the “Reference waveform save [BW.SAVE]” command (READ/WRITE) (command code: 0x0307) to ON beforehand.
 - 2) By default, data is not saved in EEPROM when the reference waveform is registered with the command. When the power is turned OFF and then ON again, the reference waveform returns to the pre-registration state.

After the command is executed, the system is automatically reset from beam axis adjustment mode .

- 7.** To check whether the reference waveform has been registered after registering it, send the "Reference waveform registration status" command (READ). (Command code: 0x0363)

If the response is normal, the following response data will be returned.

Read data															
High								Low							
Bit15	Bit14	Bit13	Bit12	Bit11	Bit10	Bit9	Bit8	Bit7	Bit6	Bit5	Bit4	Bit3	Bit2	Bit1	Bit0
Reserved														Status	

Details of "Status"

0	The "Reference waveform registration execution" command (WRITE) that was executed last time is successful.
1	The "Reference waveform registration execution" command (WRITE) that was executed last time is unsuccessful and the reference waveform status has not been updated from the previous state. (If the power is turned OFF and then ON, the history of beam axis adjustment failures will be erased.)
2	Reference waveform registration is in progress.

- 8.** To quit beam axis adjustment mode without registering the reference waveform, send the "Beam axis adjustment end" command (WRITE). (Command code: 0x0364)

4-13 Communication response speed

Between a controller and a CPU unit, the times from a response data change request until a response and from a command request until a response are as follows.
 (*Note that the measured time will vary depending on the operating environment.)

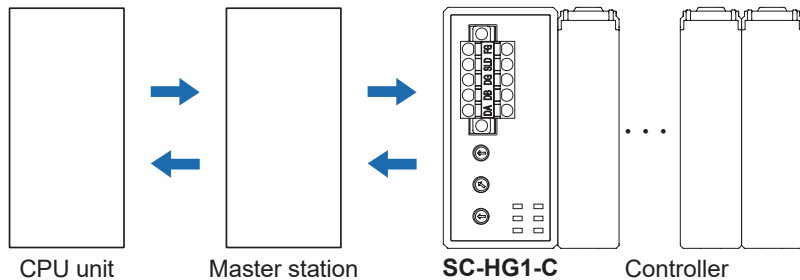

<Reference> Communication speed: 156kbps

Number of connected controllers: 1		mode 1	mode 2	mode 3
Controller response data change		52.6ms	270.0ms	174.9ms
Command response	Read	52.2ms	233.3ms	174.8ms
	Write	52.9ms	279.5ms	184.3ms
Number of connected controllers: 15 (*1)		mode 1	mode 2	mode 3
Controller response data change		171.3ms	288.0ms	173.1ms
Command response	Read	281.5ms	234.4ms	161.2ms
	Write	286.5ms	296.4ms	187.5ms

<Reference> Communication speed: 10Mbps

Number of connected controllers: 1		mode 1	mode 2	mode 3
Controller response data change		6.9ms	30.3ms	19.2ms
Command response	Read	6.3ms	37.5ms	19.8ms
	Write	11.7ms	41.1ms	26.3ms
Number of connected controllers: 15 (*1)		mode 1	mode 2	mode 3
Controller response data change		20.7ms	34.7ms	20.8ms
Command response	Read	33.0ms	37.3ms	20.5ms
	Write	48.7ms	41.6ms	28.5ms

*1: When 15 controllers (one master unit, 14 slave units) are connected, mode 1 includes the page change time.

4-14 Self-monitoring Function

Self-monitoring Function enables the sensor itself to judge various statuses (“normal status”, “unstable detection status”, “caution-required status”, and “abnormal status”) within its own device and send the status information to the host device. **HG-S** series, and **HG-T** series sensors incorporate the self-monitoring function.



The self-monitoring function is not supported by **SC-HG1-C** communication units manufactured in November 2019 or earlier.
Use a **SC-HG1-C** communication unit manufactured in December 2019 or later.

4-14-1 Using the Self-monitoring Function

By combining the control system connected to PLC or PC via a network, this product, and the sensor(**HG-S** series, **HG-T** series) you can easily check the sensor status (normal, notification, caution, or fault). The sensor itself judges even the causes of cautions and errors, making cause investigation easier.

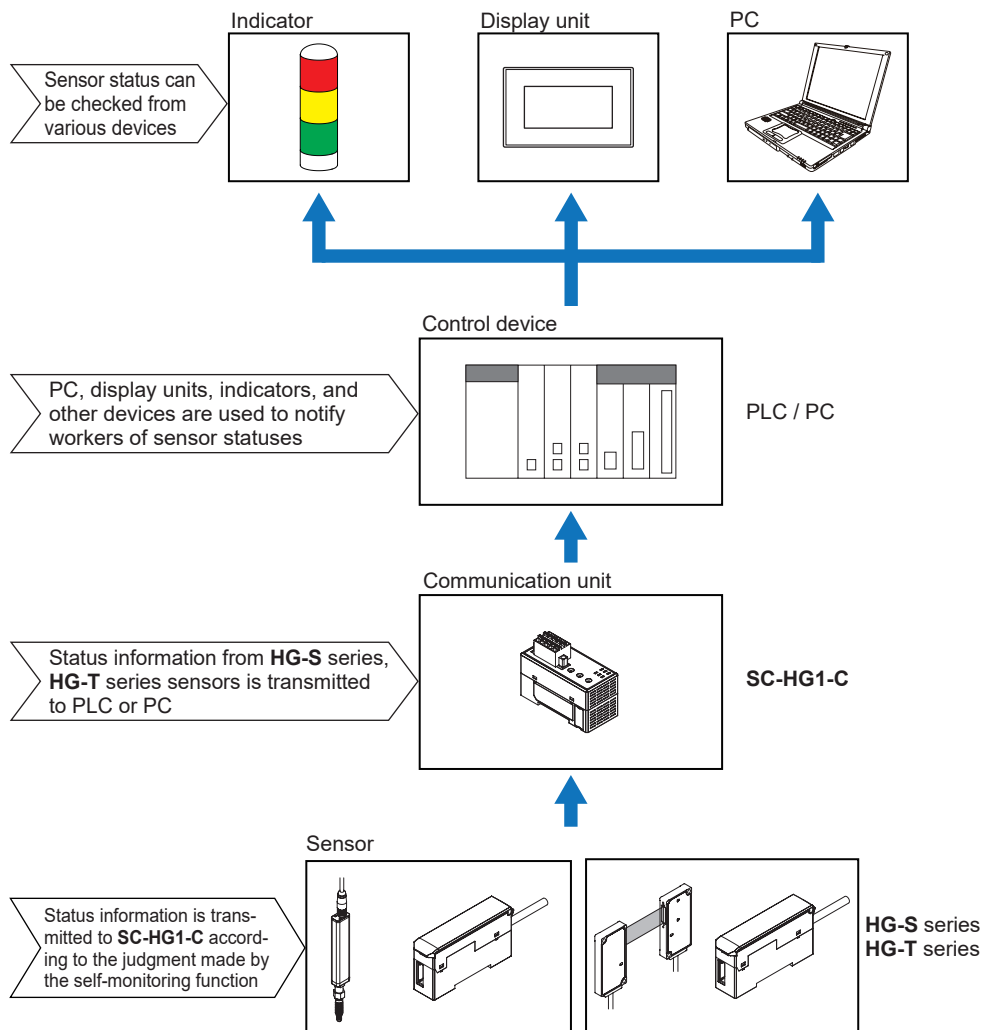

4-14-2 Statuses and Measures

The statuses judged by the self-monitoring function are classified into the following four categories. When the status is “notification”, “caution”, or “fault”, you must check the installation state or maintain or replace the product.

Status	Description	Remarks
Normal	Normal state	The device is operating normally.
Notification	Unstable detection state	Review the settings.
Caution	State in which the device must be replaced	The device has almost reached its service life.
Fault	State in which the device is uncontrollable	The device is short-circuited or broken.

If “notification”, “caution”, or “fault” status is notified, take measures as shown in the following table.

● **HG-SC** series

For details on Response Parameter address, refer to “**4-10-1 HG-S series command list**”.

	Response parameter	Measures	Error code (Note)	Alarm (Note)
Notification	Sensor head unconnected	Status check	E200	—
	Connected unit count check error	Status check	E160 (For master units only)	—
	NPN / PNP output type mixture error	Status check	E100 (For master units only)	—
	Calculated unlit count error	Status check	E110 (For master units only)	—
	Copy executionerror (Slave unit problem)	Status check	E170 (For master units only)	—
	The thrust on the sensor head stroke is above the specified range.	Status check	E210	—
	Pressure check	Status check	—	Alarm
Catch check	Status check	—	Alarm	
Fault	Controller memory function damaged	Controller replacement	E600 / E610 / E620	—
	Sensor Head memory function damaged	Sensor head replacement	E630	—
	Output section short-circuit error	Status check / Replacement	E700	—
	Detection circuit damaged	Sensor head replacement	E240	—
	System error	Controller replacement	E900 / E910 / E911 / E912 / E920	—

Note: Error codes and alarms are displayed on **HG-SC** controllers.

CC-LINK Network Communication

● HG-TC series

For details on Response Parameter address, refer to “4-10-2 HG-T series command list”.

	Response parameter	Measures	Error code (Note 1)	measurement alarm (Note 1)
Notification	Sensor head unconnected	Status check	E200	–
	Connected sensor head incompatible	Status check	E230	–
	Connected unit count check error	Status check	E160 (For master units only)	–
	NPN / PNP output type mixture error	Status check	E100 (For master units only)	–
	Calculated unlit count error	Status check	E110 (For master units only)	–
	Copy execution error (Slave unit problem)	Status check	E170 (For master units only)	–
	Detection capability limit (obtained edge information) (Note 2)	Sensing object check	–	Measurement alarm 1
	The amount of entering light is too much due to the influences of ambient light, etc. (Note 2)	Status check	–	Measurement alarm 1
	The amount of entering light decreases due to stain on the detection surface, beam axis misalignment, etc.	Sensing object check	–	Measurement alarm 2
	The specified measurement direction differs from the insertion direction of the detected object	Status check / Sensing object check	–	Measurement alarm 2
Caution	Controller cumulative run time limit exceeded (87,600 hours)	Controller replacement	–	–
	Sensor head cumulative run time limit exceeded (87,600 hours)	Sensor head replacement	–	–
	Controller memory saving count limit exceeded (1,000,000 times)	Controller replacement	–	–
	Sensor head memory saving count limit exceeded (for receivers only, 1,000,000 times)	Sensor head replacement	–	–
Fault	Controller memory function damaged	Controller replacement	E600 / E610 / E620	–
	Sensor head memory function damaged	Sensor head replacement	E630 (For receivers only) E640 (For emitters only)	–
	Output section short-circuit error	Status check / Replacement	E700	–
	Detection circuit damaged	Sensor head replacement	E240	–
	System error	Controller replacement	E900 / E910 / E911 / E912 / E920	–

Notes: 1) Error codes and alarms are displayed on **HG-TC**□ controllers.

2) If “Alarm condition selection (ALM.CND)” is set to “Hold last value (HOLD)”, Measurement alarm 1 is not notified.

4-15 Other precautions

- For the **HG-T** series controllers, waveform values will be temporarily reset during measurement if the following commands are written.

Command code	Name	Remarks
0x001E	BANK LOAD execution (LOAD)	—
0x0046	Average count (SPEED)	—
0x0047	Measurement direction (DIRECT)	—
0x0048	Alarm delay count (DELAY)	For write only
0x0059	Sampling cycle (SAMPLI)	For write only
0x0300	Operation mode (OP.MODE)	For write only
0x0304	Sensitivity setting	For write only
0x0305	Judgment level (JDG.LVL)	For write only
0x0306	Judgment filter (JDG.FIL)	For write only
0x030C	Stain check (STA.CHK)	For write only
0x030D	Stain threshold (STA.THR)	For write only
0x031E	Sensor head cumulative run time (HD.TIME)	—
0x0325	Reverse insertion check (DIR.CHK)	For write only
0x03EF	Reverse of measured value (REVERS)	For write only

- For the **HG-T** series controllers, approximately five seconds after the power is turned ON, measured values are synchronously collected from the heads connected to each controller.

(MEMO)

5 Specifications

5-1 Specifications	5-2
5-2 Dimensions	5-3

Specifications

5-1 Specifications

Product name	CC-Link communication unit				
Model	SC-HG1-C				
Compatible controllers	HG-SC□,HG-TC□				
Maximum number of connectable controllers	Maximum of 15 controllers (one master, 14 slaves) per SC-HG1-C unit				
Supply voltage (Note)	24V DC ±10%, Ripple 10% or less				
Current consumption	80mA or less				
Communication method	CC-Link Ver.1.10 / Ver.2.00 Selectable				
Remote station type	Remote device station				
Number of occupied stations	CC-Link Ver.1.10: 4 stations, CC-Link Ver.2.00: 2 stations / 4 stations Selectable				
Cyclic transmission (Maximum number of links per station)	<p><RX / RY> Mode 1: 128 points each (128 bits), 16 bytes Mode 2: 384 points each (384 bits), 48 bytes Mode 3: 448 points each (448 bits), 56 bytes</p> <p><RW_r / RW_w> Mode 1: 16 points each (16 words), 32 bytes Mode 2: 64 points each (64 words), 128 bytes Mode 3: 64 points each (64 words), 128 bytes</p>				
Station number setting	1 to 64 (0 and 65 or higher result in error)				
Communication speed	156kbps	625kbps	2.5Mbps	5Mbps	10Mbps
Transmission route type	Line type				
Maximum transmission distance	1,200m	900m	400m	160m	100m
Ambient temperature	-10 to +45°C (No condensation or icing), Storage: -20 to +60°C				
Ambient humidity	35 to 85% RH, Storage: 35 to 85% RH				
Withstand voltage	1,000V AC for one minute between all supply terminals and case				
Insulation resistance	20MΩ or higher, using 250V DC megger connected between all supply terminals and case				
Vibration resistance	10 to 150Hz with 0.75mm amplitude in X, Y and Z directions for two hours each				
Shock resistance	98m/s ² (approx. 10G) in X, Y and Z directions 5 times each				
Communication cable	Dedicated cable certified by CC-Link Partner Association (shielded 3-conductor twisted-pair cable)				
Material	Unit cases: Polycarbonate				
Weight (main unit only)	Approx. 80g				

Note: Power is supplied from a connected controller / master controller.

5-2 Dimensions

Unit: mm

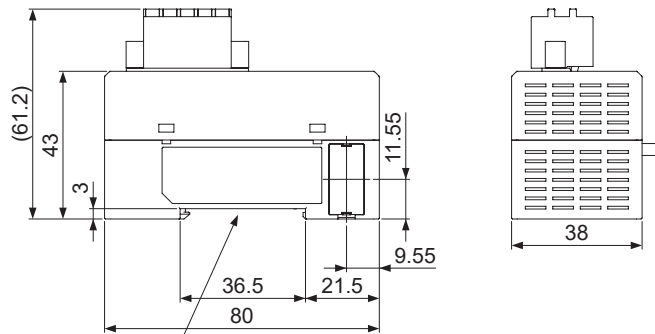
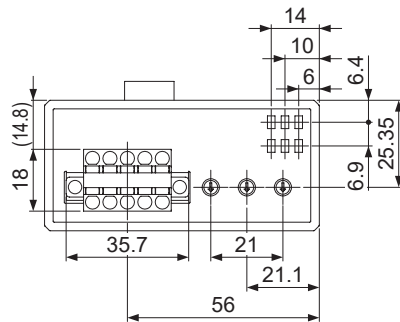

Compatible with 35mm width DIN rail

(MEMO)

6 Warranty

6-1 When you purchase and use the product6-2

Warranty

6-1 When you purchase and use the product

The product and specifications described in this manual are subject to change without notice (including specification changes and termination of production). When you place an order, check with the representative to make sure the information in the manual is up to date.

Our company works hard to improve product quality and reliability; however, electrical components and devices generally fail at a certain probability rate. The environment and conditions of use also affect durability.

Always conduct testing using the actual product in the conditions of use before deploying the product. Risk of abnormal heat generation, smoke emission, and fire due to isolation deterioration if you continue to use the product after performance has deteriorated. To prevent injury and death, fire, and property damage due to product failure or end of life, conduct regular maintenance and implement safety design such as redundant design, fire spreading countermeasures, and malfunction prevention.

[Cautionary points regarding applications]

- This product has been developed and manufactured for industrial use only.
- Before using this product in a system, machine, or other equipment, check all applicable standards, regulations, and laws. Please verify the conformity of the product yourself. Our company bears no responsibility for product conformity in the event that the customer does not verify these matters.
- Before using the product for the applications below, consult a representative and exchange specifications. To prevent injury and death, fire, and property damage, implement thorough safety design such as redundant design, fire spreading countermeasures, and malfunction prevention.
 - Possibility of use in an environment or under conditions that exceed the specifications and ranges indicated in this catalog, such as outdoor use, use in a chemically contaminated environment, or use in an environment subject to the effects of electromagnetic radiation.
 - Use in transportation equipment or other systems, machinery, instruments, or 24-hour continuous operation systems that pose a potential risk of death, injury, or property damage; especially applications that require high reliability.
 - Any other applications that require a high level of safety in conformity with the above.
- The applications indicated in the catalog are examples for reference only. Verify equipment / system functionality and safety before using the product. This product cannot be used in any human protective detection applications other than that of a safety sensor.
- Always observe the safety information indicated in the catalog and manual to prevent incorrect use that results in unexpected harm or damages to the customer or a 3rd party.

[Receiving inspection]

- Please conduct receiving inspection promptly when the product is delivered, and implement thorough management maintenance prior to and during inspection of the product.

[Warranty period]

- Unless otherwise agreed upon, the warranty period for our company's products is one year after purchase or delivery to the customer's specified location. The warranty does not apply to consumables and supplies such as batteries and light-source lamps.

[Scope of warranty]

- If a failure or defect for which our company is responsible is discovered during the warranty period, our company will provide a substitute product or required replacement parts free of charge, or will replace or repair the defective part free of charge at the location where the product was purchased or delivered.

Failures and defects to which any of the following apply are excluded.

- (1) The problem originated in the customer's specifications, standards, or handling procedures.
- (2) The problem originated in structural, performance, specification, or other modifications made by the customer after purchase or delivery without our approval.
- (3) The problem was caused by a phenomenon not foreseeable by technology in practical application at the time of purchase or contract.
- (4) The product was used outside of the condition / environment ranges indicated in the catalog and specifications.
- (5) When our product was incorporated and used in the customer's equipment, damages occurred that could have been avoided if the customer's equipment had a structure, functions, or other features commonly accepted in the industry.
- (6) The problem was caused by a natural disaster or other Act of God.

"Warranty" as used here is limited to the product itself that was purchased or delivered. Damages caused by a failure or defect in our product are excluded.

[Scope of service]

- Expenses for service such as dispatching a technician are not included in the product price. If you are interested in service, please consult with a sales representative

The above applies to purchases and use in Japan.

For questions and information on specifications, warranties, and service related to purchases and use in regions other than Japan, please consult a representative.

(MEMO)

7 Maintenance

7-1 Maintenance and Inspection	7-2
7-1-1 Maintenance cautions	7-2
7-1-2 Main inspection items	7-2

Maintenance

7-1 Maintenance and Inspection

7-1-1 Maintenance cautions

- Always turn OFF the power before cleaning the unit.
- Never use thinner, benzene, or other organic solvents to clean the unit.
- Use a clean, soft cloth to wipe off any dirt that adheres to the unit.

7-1-2 Main inspection items

Inspect the unit regularly to maintain performance and enable optimum use. The main inspection items are as follows:

- Have any input / output terminals become loose or come OFF?
- Is the supplied power within the rated voltage range (24V DC $\pm 10\%$)?
- Is the ambient operating temperature within the specified range (-10 to +45% RH)?
- Is the ambient operating humidity within the specified range (35 to 85% RH)?

8 Troubleshooting

8-1 Command error	8-2
8-2 Communication errors	8-5
8-3 Description of indicators	8-6
8-4 What to do when a problem occurs	8-7

Troubleshooting

Solutions to frequently encountered problems and errors are described below.

8-1 Command error

A command error will occur in response to a sent command if the command setting is outside the range. Check the error code and take appropriate action.
 The example of an out-of-range parameter error in slave unit 2 when the LOW set value command "0x0014" (write) is sent to a master unit and slave units 1 to 3 is given below. () is only set when the operation mode is CC-Link mode 1.
 For error codes and solutions, refer to "<Table of error codes>".

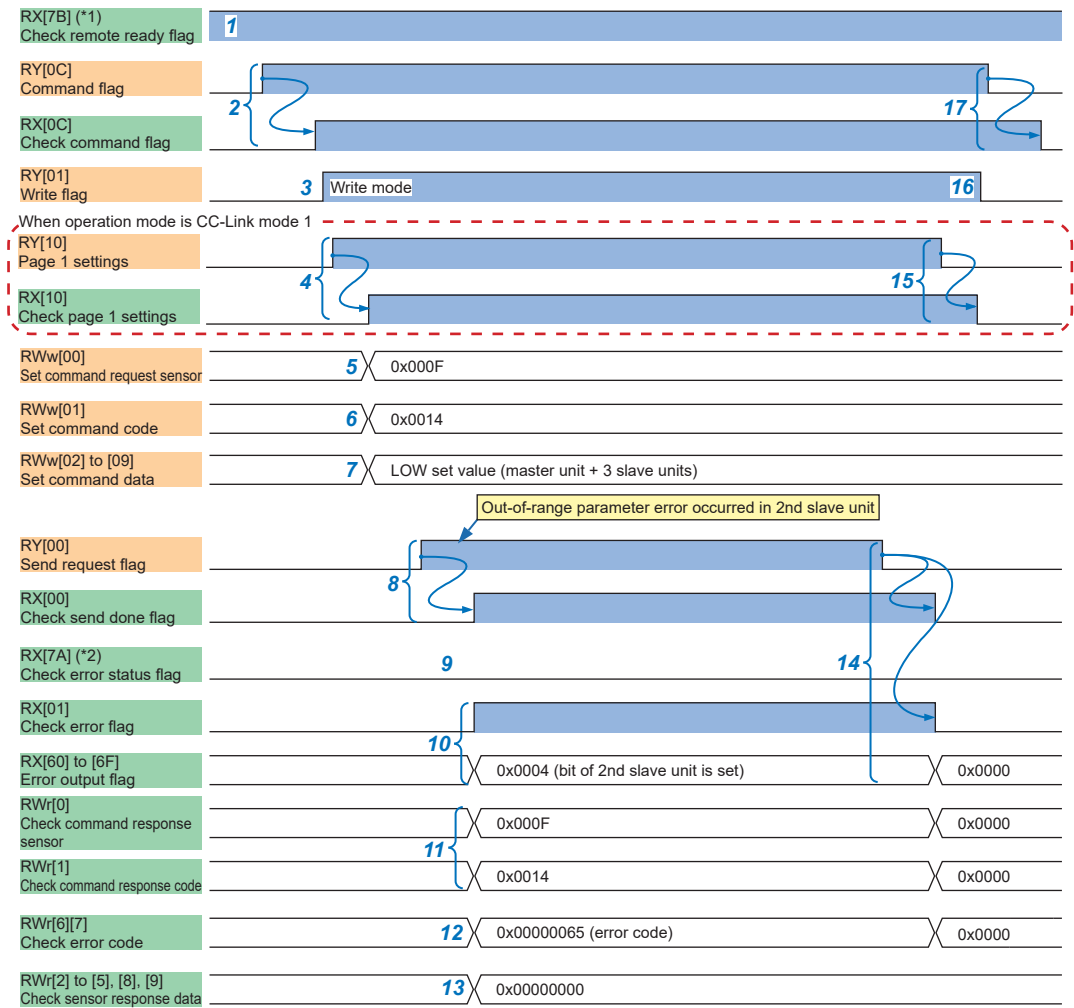

1. Check that RX[7B]: remote ready flag (*1) is set.
2. Set RY[0C]: command flag and then check that RX[0C]: command flag is set. This changes the mode to command mode. Clear sensor response data switching request flags other than the command flag in advance.
3. Set the RY[01]: write flag and activate Write mode.

4. If the operation mode is CC-Link mode 1, set RY[10]: page 1. Page 1 settings are requested, and RX[10]: page 1 is set. In CC-Link mode 1, always configure the page settings. The page settings of the sensor response data (master unit, slave units 1 to 14) are as shown in the table below.

Sensor response data	RY[10]	RY[11]	RY[12]
Master unit, slave units 1 to 6	1	0	0
Slave units 7 to 13	0	1	0
Slave unit 14	0	0	1

5. Specify the controller to which the command will be sent with RWw[0]: command request sensor.
6. Set the command code to be sent to RWw[1].
7. Set the command data to be sent to RWw[2] to [9].
8. Set RY[00]: send request flag and send the command. When command transmission is completed, RX[00]: send done flag is set. Verify that RX[00]: send done flag is set, and then proceed with the steps below.
9. Verify that a communication error has not occurred with the RX[7A]: error status flag (*2) cleared. If a communication error has occurred, refer to “**8-2 Communication errors**”.
10. Because a command error occurred, RX[01]: error flag is set. Among the RX[60] to [6F] error output flags, the bit corresponding to the controller in which the error occurred is set at the same time.
11. The value specified in step 5 (master unit, slave unit 1, slave unit 2, slave unit 3: 0x000F) is set in RWr[0]: command response sensor. The command code sent to RWr[1] is stored.
12. The error code is stored in the sensor response data of the RWr that corresponds to the controller in which the command error occurred.
13. The sensor response data of RWr that correspond to controllers in which a command error did not occur is "0".
14. Clear RY[00]: send request flag. The communication unit ends command transmission, and RX[00]: send done flag and RX[01]: error flag are cleared. RX[60] to [6F] error output flags are also cleared.
15. If the operation mode is CC-Link mode 1, clear RY[10]: page 1. Page 1 settings are cleared, and RX[10]: page 1 is cleared.
16. Clear RY[01]: write flag.
17. Clear RY[0C]: command flag. The communication unit exits command mode, and RX[0C]: command flag is cleared. After removing the cause of the error, re-execute the command.

*1: The bit position depends on the operation mode.

CC-Link mode 1: RX[7B], CC-Link mode 2: RX[17B], CC-Link mode 3: RX[1BB]

*2: The bit position depends on the operation mode.

CC-Link mode 1 : RX[7A], CC-Link mode 2: RX[17A], CC-Link mode 3: RX[1BA]

Troubleshooting

<Table of error codes>

The following table shows error codes and corrective actions.

Error code		Description	Action
DEC	HEX		
100	0x0064	A command was received that is not in the command list.	The command code is invalid. Check "4-10 Commands" for the correct code.
101	0x0065	An out-of-range setting parameter was requested.	Invalid setting parameter. Check the settable parameter values in "4-10 Commands".
102	0x0066	A write request using an unusable setting was made in the target controller.	Invalid setting parameter. Check the settable parameter values in "4-10 Commands".
103	0x0067	A read request using an unusable setting was made in the target controller.	Invalid setting parameter. Check the settable parameter values in "4-10 Commands".
200	0x00C8	A sensor head is not connected.	Check the status of the sensor head connection.
400	0x0190	When calibration was executed, an alarm, undefined, or over display range state was in effect.	Invalid sensor head value. Check the state of the sensor head.
401	0x0191	Calibration was not executed normally.	Calibration failed. For the calibration procedure, refer to the user's manual of the controller that you use.
500	0x01F4	When teaching was executed, an alarm, undefined, or over display range state was in effect.	Invalid sensor head value. Check the state of the sensor head.
501	0x01F5	Unable to execute teaching.	Teaching failed. For the teaching procedure, refer to the user's manual of the controller that you use.
600	0x0258	When preset was executed, an alarm, undefined, or over display range state was in effect.	Invalid sensor head value. Check the state of the sensor head.
700	0x02BC	When bank load or bank save was executed, the bank number was outside the range.	Invalid setting parameter. Check the settable parameter values in "4-10 Commands".
800	0x0320	Unable to write to internal memory.	The controller may have failed. Replace the controller.
900	0x0384	A response was not received from the controller for 100ms after the command request was sent.	Check the status of the controller connection.
1900	0x0076C	A normal command was not sent. Abnormal measured value block information. The communication unit process timed out.	Check the status of the communication unit connection.
2200	0x0898	A request was made to a controller / slave unit that is not connected.	A command request was made to a controller / slave unit that does not exist. Check the command request controller.
2400	0x0960	A command request was received while recovering from a horizontal connection error.	A command was requested while recovering from an error. Wait until controller processing finishes before requesting a command.
2500	0x09C4		
2600	0x0A28	The controller is busy.	Another command was requested while the controller was busy. Wait until controller processing finishes before requesting a command.
2800	0x0AF0	A CRC error occurred during communication between controllers	Noise may have caused the CRC error to occur. Check the wiring.
2900	0x0B54	A timeout error occurred during communication between controllers	Check the status of the controller connection.

Error code		Description	Action
DEC	HEX		
3100	0x0C1C	More than 14 controllers / slave units are connected.	The maximum number of controllers / slave units that can be connected is 14. Check the number of connected controllers / slave units.
3200	0x0C80	CC-Link communication is not taking place.	The data link was broken. Check the connection state of the connectors.
4095	0x0FFF	Request not accepted because the controller was busy processing a command.	Another command was requested while the controller was busy processing a previous command. Wait until controller processing finishes before requesting a command.

Note: This product cannot detect errors that occur in a controller.

To check the error code in a controller, use a 0x0001 command (status / error) in command mode to read the error code.

8-2 Communication errors

If an error occurs, set RY[7A]: clear error request (*1) to clear the error state.

If the error does not clear when RY[7A]: clear error request (*1) is set and RX[7B]: remote ready flag (*2) does not set, check the state of the connection with the communication unit and then restart.

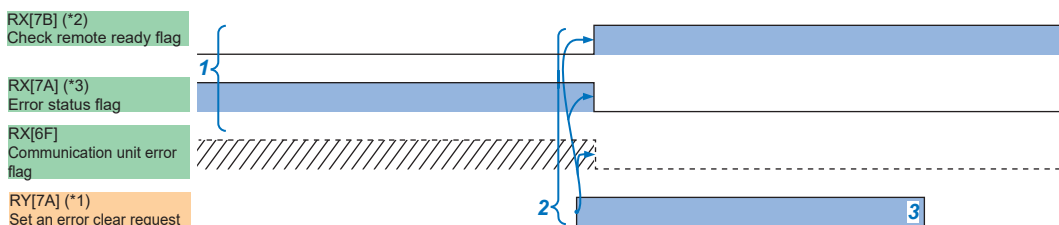

1. Check that RX[7B]: remote ready flag (*2) is cleared and RX[7A]: error flag (*3) is set.
RX[6F]: communication unit error flag indicates whether or not an error state is due to a problem in the communication unit. If the problem is in the communication unit, RX[6F]: communication unit error flag is set.
2. Set RY[7A]: clear error request (*1). This operation causes the communication unit to clear RX[7A] (*3): error status flag and sets RX[7B] (*2): remote ready flag. At this time, if RX[6F]: communication unit error flag is set, RX[6F]: communication unit error flag will also be cleared. (*4)
If RX[7B]: remote ready flag is not set when the above operation is performed, this indicates that the error was caused by a problem that does not allow recovery by operation. In this event, remove the cause of the error and cycle the power OFF - ON.
3. Clear RY[7A]: clear error request (*1).

*1: The bit position depends on the operation mode.

CC-Link mode 1: RY[7A], CC-Link mode 2: RY[17A] CC-Link, mode 3: RY[1BA]

*2: The bit position depends on the operation mode.

CC-Link mode 1: RX[7B], CC-Link mode 2: RX[17B], CC-Link mode 3: RX[1BB]

*3: The bit position depends on the operation mode.

CC-Link mode 1: RX[7A], CC-Link mode 2: RX[17A], CC-Link mode 3: RX[1BA]

*4: You can enter error mode and check the error code.

For details on error mode, refer to “4-9 Error mode”.

Troubleshooting

8-3 Description of indicators

You can check the indicators on the product to identify the cause of a problem and take corrective action.

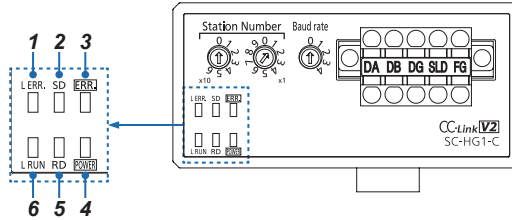

	Name	Function
1	L ERR. indicator (Red)	Lights up if the station number setting switch and communication speed setting switch are in an invalid setting position when the power is turned on. Blinks if the switch type setting is changed while the power is on.
2	SD indicator (Green)	Lights up during data sending.
3	ERR. indicator (Red)	Lights up when CC-Link communication is interrupted. Blinks when an error occurs in communication between controllers.
4	Power indicator (Green)	Lights up when power is supplied.
5	RD indicator (Green)	Lights up during data reception.
6	L RUN indicator (Green)	Lights up during data link execution.

8-4 What to do when a problem occurs

■ Power indicator (Green) is not lit

Cause	Solution
Power is not supplied.	Check if the capacity of the power supply is sufficient. Connect the power supply correctly.
The power supply voltage is not within the specifications.	Correctly set the power supply voltage.
A connector for connection to a controller is not firmly connected.	Firmly connect the connector.

■ L_ERR indicator (RED) is lit or blinking

State	Cause	Solution
ON	An out-of-range station number was set when the power was turned on.	Check if the switch type setting is correct. Cycle the power OFF - ON.
Blinking	The switch type setting was changed after the power was turned on.	Change the switch type setting to the setting that was in effect before the power was turned on. To apply a change, cycle the power OFF - ON.

■ ERR indicator (RED) is lit or blinking

State	Cause	Solution
ON	CC-Link communication has been interrupted.	Check if the CC-Link connectors are correctly connected. Connect correctly.
	CC-Link data link has failed.	Check if the parameter settings and switch type setting are correct. Cycle the power OFF - ON.
Blinking	Communication between controllers is not taking place normally.	Check the connection of connected units. Cycle the power OFF - ON.

■ An EEPROM error (E600 or E620) is displayed on the connected controller.

Cause	Solution
A command is sent immediately after the power supply is turned ON.	Send a command after five seconds has elapsed since the power supply is turned ON.

<Important>

If the product still does not operate normally after you check the above, consult our technical support center.

(MEMO)

Revision history	Revision date	Revision item
First edition	1/27/2017	—
Second edition	9/8/2017	—
Third edition	9/30/2019	—
Fourth edition	12/1/2019	Commands related to the self-monitoring function were added “4.7 Self-monitoring Function” added
Fifth edition	12/1/2020	Commands related to the addition of HG-T functions have been added.
Sixth edition	4/1/2024	Made revisions in line with the change of the company name.

(MEMO)

(MEMO)

Panasonic Industry Co., Ltd.

1006, Oaza Kadoma, Kadoma-shi, Osaka 571-8506, Japan
<https://industry.panasonic.com/>

Please visit our website for inquiries and about our sales network.

© Panasonic Industry Co., Ltd. 2017-2024

April, 2024

WUME-SCHG1C-6