

Touch Terminals

## HMs700 Series Instruction Manual

---



Subject to change without notice.

The information contained in this manual is provided for informational purposes only. While efforts were made to verify the accuracy of the information contained in this manual, it is provided “as is” without warranty of any kind.

Third-party brands and names are the property of their respective owners.

This manual and everything described in it are copyrighted. You may not copy this manual, in whole or part, without written consent of Panasonic.

Please direct support matters and technical questions to your local Panasonic representative.

Distributed by Panasonic Industry Europe GmbH  
<https://industry.panasonic.eu>

# Table of contents

---

<b>1. Introduction</b>	<b>4</b>
<b>2. Important symbols</b>	<b>4</b>
<b>3. Special instructions for use</b>	<b>5</b>
<b>4. Standards and approvals</b>	<b>6</b>
4.1 HMs705	6
4.2 HMs707, HMs710, HMs715, HMs721	6
<b>5. Product overview</b>	<b>7</b>
<b>6. Product identification</b>	<b>7</b>
<b>7. Technical data common to all models</b>	<b>8</b>
7.1 Hardware specifications	8
7.2 Environmental conditions	8
7.3 Electromagnetic compatibility (EMC)	9
7.4 Durability information	9
7.5 Viewing angles	10
7.6 Touchscreen properties	10
<b>8. Technical data by model</b>	<b>11</b>
8.1 HMs705, HMs707, HMs710	11
8.2 HMs715, HMs721	12
<b>9. Product dimensions</b>	<b>13</b>
<b>10. Unpacking and packing instructions</b>	<b>17</b>
<b>11. Installation</b>	<b>18</b>
11.1 Installation environment	18
11.2 Installation procedure	18
<b>12. Connections</b>	<b>19</b>
12.1 Ethernet port	19
12.2 Power supply, grounding, and shielding	19
<b>13. Battery</b>	<b>20</b>
<b>14. Getting started</b>	<b>22</b>
<b>15. Disposal</b>	<b>22</b>
<b>16. Record of changes</b>	<b>23</b>

## 1. Introduction

---

This instruction manual contains information about the installation, transportation, storage, assembly, use and maintenance of touch terminals of the HMs700 series.

The following models are available:

**HMs705** Touch terminal with 5" TFT color widescreen, multi-touch capacitive touchscreen, Ethernet port PoE

**HMs707** Touch terminal with 7" TFT color widescreen, multi-touch capacitive touchscreen, Ethernet port PoE

**HMs710** Touch terminal with 10.1" TFT color widescreen, multi-touch capacitive touchscreen, Ethernet port PoE

**HMs715** Touch terminal with 15.6" TFT color widescreen, multi-touch capacitive touchscreen, Ethernet port PoE

**HMs721** Touch terminal with 21.5" TFT color widescreen, multi-touch capacitive touchscreen, Ethernet port PoE

## 2. Important symbols

---

One or more of the following symbols may be used in this documentation to indicate the type of hazard.

### **DANGER**

Indicates a hazardous situation which, if not avoided, will result in death or serious injury.

### **WARNING**

Indicates a hazardous situation which, if not avoided, could result in death or serious injury.

### **CAUTION**

Indicates a hazardous situation which, if not avoided, could result in serious or moderate injury.

### **Notice**

Indicates a property damage message.

### 3. Special instructions for use

---

- The product shall only be used in an area of not more than pollution degree 2, as defined in IEC/EN 60664-1.
- The product shall be installed in an enclosure that provides a degree of protection not less than IP54 in accordance with IEC/EN 60079-15.
- Transient protection shall be provided that is set at a level not exceeding 140% of the peak rated voltage value at the supply terminals to the product.
- Install the product according to the accompanying installation instructions.
- Ground the product according to the accompanying installation instructions.
- Only qualified personnel may install or repair the product.
- Care shall be taken to avoid that layers of dust form on the touch terminals in a way that might cause the accumulation of static charges.
- Keep the faceplate of the product clean. The product must be cleaned only with a soft cloth and neutral soap product. Do not use solvents.
- This product should not be used for purposes and methods other than indicated in this document and in the documentation accompanying the product.

## 4. Standards and approvals

---

The products are in compliance with the Restrictions on Certain Hazardous Substances (RoHS) Directive 2011/65/EU.

In compliance with the relevant regulations the products are CE marked.

### 4.1 HMs705

---

The product has been designed for use in an industrial environment in compliance with the 2014/30/EU EMC Directive.

The product complies with the following standards:

EN 61000-6-4	EN 61000-4-2	CISPR 22 Class B
EN 61000-6-3	EN 61000-4-3	CISPR 16-2-3
EN 61000-6-2	EN 61000-4-4	
EN 61000-6-1	EN 61000-4-5	
	EN 61000-4-6	
	EN 61000-4-8	

### 4.2 HMs707, HMs710, HMs715, HMs721

---

The products have been designed for use in an industrial environment in compliance with the 2014/53/EU EMC Directive.

The products comply with the following standards:

EN 61000-6-4	ETSI EN 301 489-1	EN 62311
EN 61000-6-3	ETSI EN 301 489-17	EN 61010-1
EN 61000-6-2	ETSI EN 300 328	EN 61010-2-201
EN 61000-6-1		

Standard radio signal: Wi-Fi 2.4GHz (calculated according to EN 62311)

Minimum distance form the body: 2cm (calculated according to EN 62311)

The Wi-Fi antenna is positioned behind the black band above the display.

## 5. Product overview

---

The HMs700 series touch terminals are ideal for field installation in critical areas. They are equipped with a high resolution display and a multi-touch capacitive touchscreen with a robust glass front.

Power over Ethernet (PoE) technology is available for maximum connectivity through standard CAT5 wiring. The HMs700 series can be installed under difficult environmental conditions (IP67 protection) and can be mounted to all standardized support arm systems. The product features environment and motion sensors and has been designed as IIoT edge device for Industry 4.0 applications.

The HMs700 series touch terminals have been optimized to run the software HMWIN Studio for powerful HMI applications.

- Open platform for Linux applications
- OPC UA server / client gateway
- Integrated sensors (temperature and acceleration)
- Powerful browser with industry standard web engines
- Wi-Fi (HMs707, HMs710, HMs715, HMs721)

## 6. Product identification

---

The product may be identified through a plate attached to the rear cover. You will have to know the product type you are using for correct usage of the information contained in the manual.

The following information is provided by the plate:

- Product model name
- Year/week of production
- Serial number

## 7. Technical data common to all models

### 7.1 Hardware specifications

<b>Touchscreen technology</b>	Projected capacitive, multi-touch
<b>Real-time clock back-up battery</b>	3V, 7mAh lithium, rechargeable, not user-replaceable, model VL1220
<b>Flash memory</b>	4GB (HMs705, HMs707, HMs710) 8GB (HMs715, HMs721)
<b>RAM</b>	1GB (HMs705, HMs707, HMs710) 2GB (HMs715, HMs721)
<b>Real-time clock</b>	Clock/calendar with back-up battery
<b>Accuracy real-time clock (at 25°C)</b>	<100ppm

### 7.2 Environmental conditions

<b>Operating temperature (surrounding air temperature)</b>	-20 to +55°C (vertical installation)	EN 60068-2-14
<b>Storage temperature</b>	-30 to +80°C (HMs705, HMs707, HMs710)	EN 60068-2-1
	-20 to +70°C (HMs715, HMs721)	EN 60068-2-2 EN 60068-2-14
<b>Operating and storage humidity</b>	5–85% RH non-condensing	EN 60068-2-30
<b>Vibrations</b>	5–9Hz, 7mm <sub>p-p</sub>	EN 60068-2-6
	9–150Hz, 1g	
<b>Shock</b>	±50g, 11ms, 3 pulses per axis	EN 60068-2-27
<b>Degree of protection</b>	IP67 (requires appropriate accessories and cables)	EN 60529



### 7.3 Electromagnetic compatibility (EMC)

<b>Radiated disturbance test</b>	Class A (HMs707, HMs710, HMs715, HMs721)  Class B (HMs705)	CISPR 22  CISPR 16-2-3
<b>Electrostatic discharge immunity test</b>	8kV (air electrostatic discharge) 4kV (contact electrostatic discharge)	EN 61000-4-2
<b>Radiated, radio frequency, electromagnetic field immunity test</b>	80MHz–1GHz, 10V/m 1.4–2GHz, 3V/m 2–2.7GHz, 1V/m	EN 61000-4-3
<b>Burst immunity test</b>	±2kV DC power port ±1kV signal line	EN 61000-4-4
<b>Surge immunity test</b>	±0.5kV DC power port (line to earth) ±0.5kV DC power port (line to line) ±1kV signal line (line to earth)	EN 61000-4-5
<b>Immunity to conducted disturbances induced by radiofrequency field</b>	0.15–80MHz, 10V	EN 61000-4-6
<b>Power frequency magnetic field immunity test</b>	Enclosure, 50/60Hz, 30A/m	EN 61000-4-8

### 7.4 Durability information

<b>Backlight service life (LED type)</b>	40000 hours or more (Time of continuous operation until the brightness of the backlight reaches 50% of the rated value when the surrounding air temperature is 25°C)  * see note
<b>Surface resistance</b>	The HMs700 series front glass is resistant (no visible changes) to the following chemicals and liquids after an application time of 24 hours:  Betadine (10% povidone solution), Coffee, Cola, Dextrose (5% glucose solution), Electrode gel/paste, Ethyl alcohol (70–90%), Hydrogen chloride (0.5% solution pH=1), Hydrogen peroxide (3% solution), Isopropyl alcohol, NaCl (0.9% solution), Quaternary ammonium compound, Sodium hypochlorite

\* Extended use in environments where the surrounding air temperature is 40°C or higher may degrade backlight quality, reliability or durability.

## 7.5 Viewing angles

The viewing angles for the horizontal (L, R) and vertical (U, D) axes are specified in reference to the vertical axis of the display. The viewing angles always refer to the standard mounting orientation.

For the viewing angle values (U, D, L, R), refer to the technical data of the respective touch terminal model.

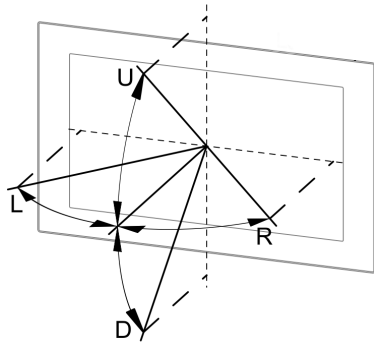

U: From top  
 D: From bottom  
 L: From left  
 R: From right

	HMs705	HMs707	HMs710	HMs715	HMs721
Horizontal viewing angle	L/R: typ. 70°	L/R: typ. 75°	L/R: typ. 85°	L/R: typ. 80°	L/R: typ. 89°
Vertical viewing angle	U: typ. 50° D: typ. 70°	U/D: typ. 75°	U/D: typ. 85°	U/D: typ. 80°	U/D: typ. 89°

## 7.6 Touchscreen properties

- Multi-touch operation: up to 5 fingers simultaneously
- Glove operation: supported

Projected capacitive touchscreens (PCAP) are suitable for operation with or without gloves. A large number of gloves (rubber gloves, light/heavy leather gloves, disposable latex gloves, etc.) are supported. However, due to the variety of commercially available gloves, we cannot guarantee the operation with all glove types.

- Passive stylus pens: supported
- Active stylus pens: not supported
- Hardened front glass: yes

## 8. Technical data by model

### 8.1 HMs705, HMs707, HMs710

	HMs705	HMs707	HMs710
<b>Display / Backlight</b>	TFT color / LED		
<b>Colors</b>	64K		
<b>Resolution (pixel)</b>	800 x 480	1024 x 600	1280 x 800
<b>Brightness</b>	300cd/m <sup>2</sup> typ.	400cd/m <sup>2</sup> typ.	
<b>Display size (inch)</b>	5" widescreen	7" widescreen	10.1" widescreen
<b>Dimming</b>	yes (to 0%)		
<b>Flash memory</b>	4GB		
<b>RAM</b>	1GB		
<b>Operating system</b>	Linux RT		
<b>CPU</b>	ARM Cortex-A9, dual core, 800MHz		
<b>Ethernet port</b>	1x 10/100Mbit PoE		
<b>USB port</b>	1 host interface version 2.0, max. 500mA (available with special cable)		
<b>Sensors</b>	temperature, 3-axis accelerometer		
<b>Real-time clock</b>	yes		
<b>Wi-Fi</b>	not available	IEEE 802.11a/b/g	
<b>Power supply</b>	802.3af		
<b>Current consumption</b>	6W	12W	14W
<b>Weight</b>	0.5kg	0.7kg	1.2kg

## 8.2 HMs715, HMs721

	HMs715	HMs721
<b>Display / Backlight</b>	TFT color / LED	
<b>Colors</b>	64K	
<b>Resolution (pixel)</b>	1366 x 768	1920 x 1080
<b>Brightness</b>	400cd/m <sup>2</sup> typ.	
<b>Display size (inch)</b>	15.6" widescreen	21.5" widescreen
<b>Dimming</b>	yes (to 0%)	
<b>Flash memory</b>	8GB	
<b>RAM</b>	2GB	
<b>Operating system</b>	Linux RT	
<b>CPU</b>	ARM Cortex-A9, quad core, 800MHz	
<b>Ethernet port</b>	1x 10/100Mbit PoE	
<b>USB port</b>	1 host interface version 2.0, max. 500mA (available with special cable)	
<b>Sensors</b>	temperature, 3-axis accelerometer	
<b>Real-time clock</b>	yes	
<b>Wi-Fi</b>	IEEE 802.11a/b/g	
<b>Power supply</b>	802.3at	802.3bt
<b>Current consumption</b>	23W	35W
<b>Weight</b>	4.0kg	6.0kg

## 9. Product dimensions

### HMs705

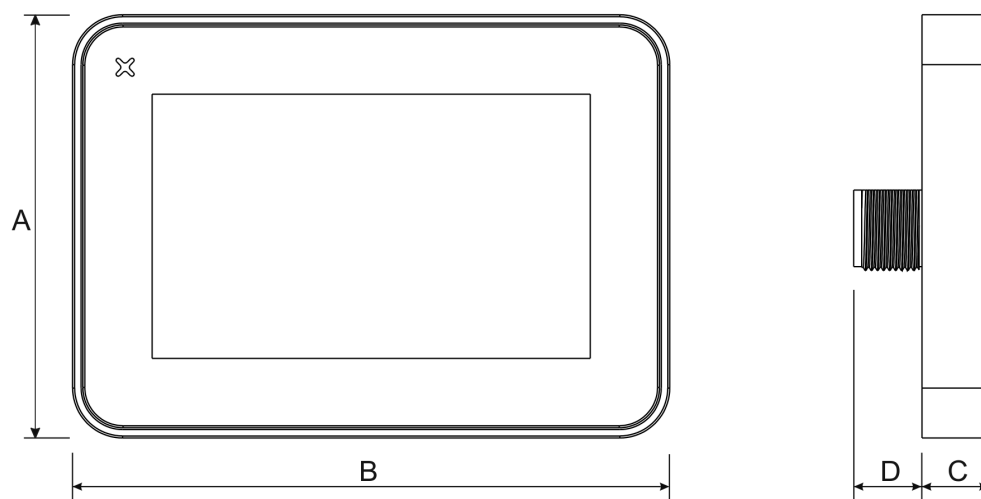

A	B	C	D
105.1mm	148.3mm	16.5mm	17mm

### Rear view

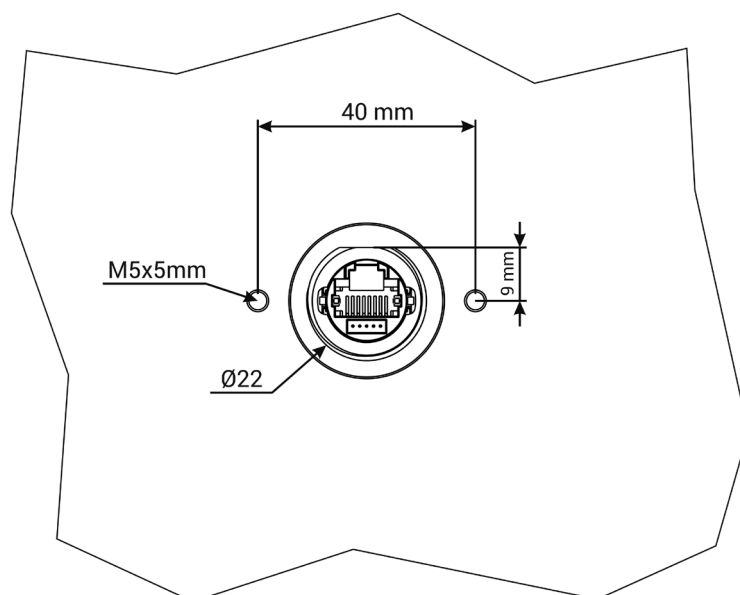

**HMs707**

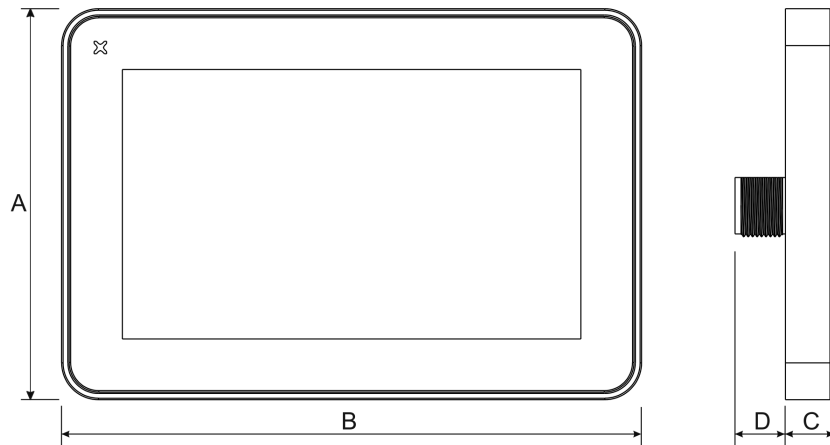

A	B	C	D
131.6mm	195.2mm	16.5mm	17mm

**HMs710**

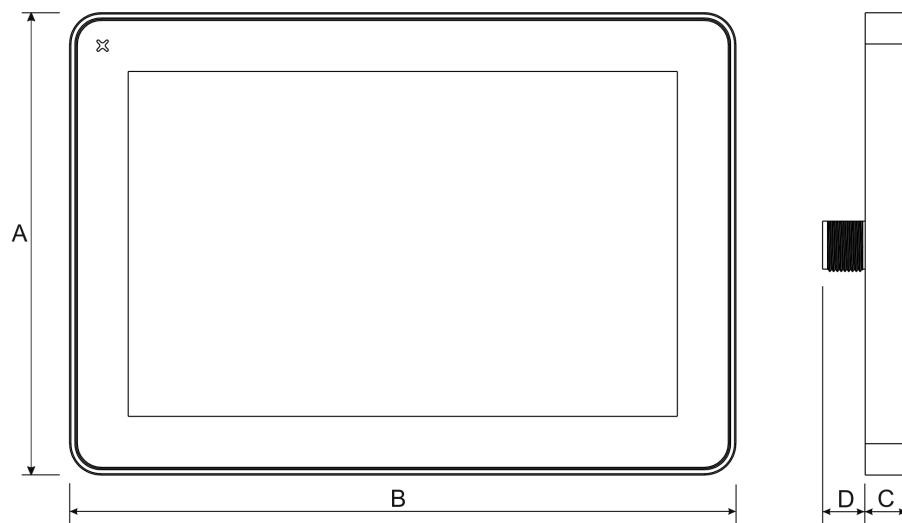

A	B	C	D
183.1mm	264.5mm	16.5mm	17mm

**HMs715**

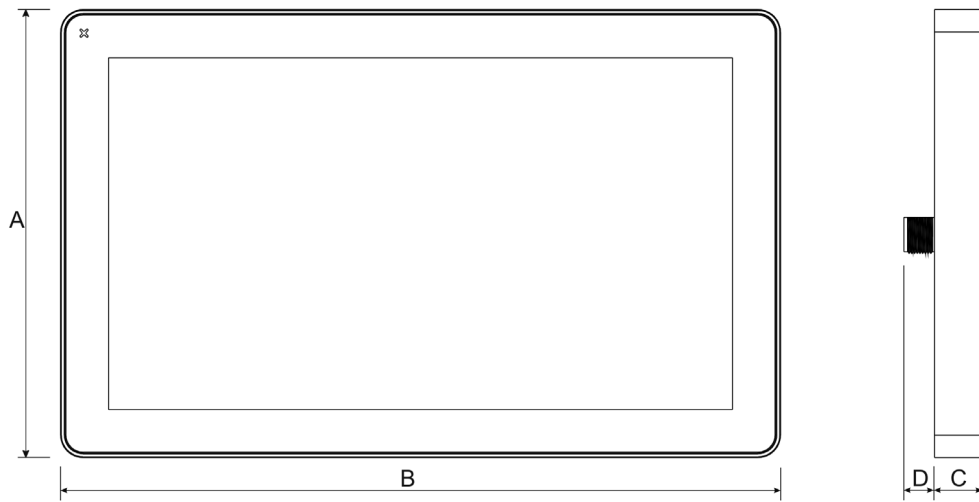

A	B	C	D
248mm	398.6mm	26.5mm	17mm

**HMs721**

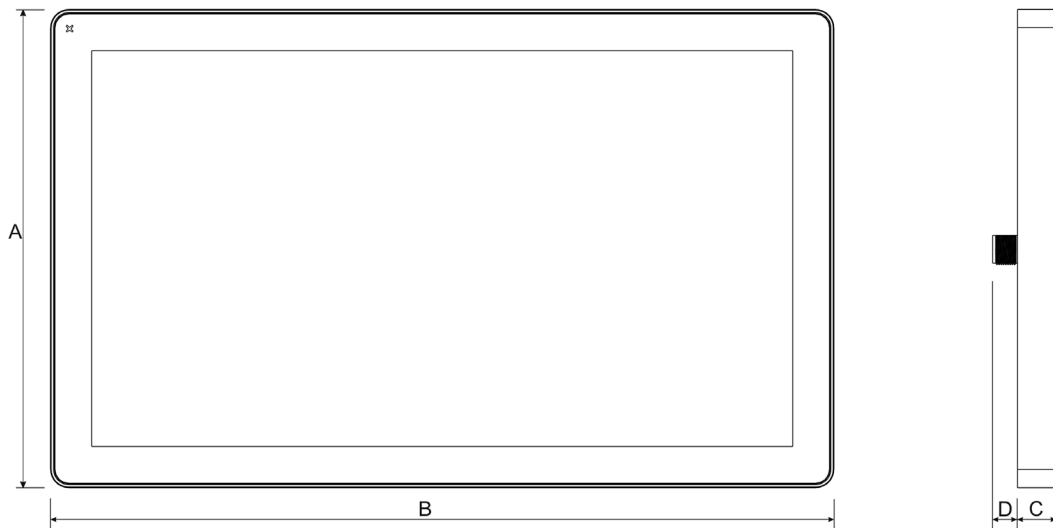

A	B	C	D
325.6mm	534.1mm	26.5mm	17mm

Rear view of HMs707, HMs710, HMs715, HMs721

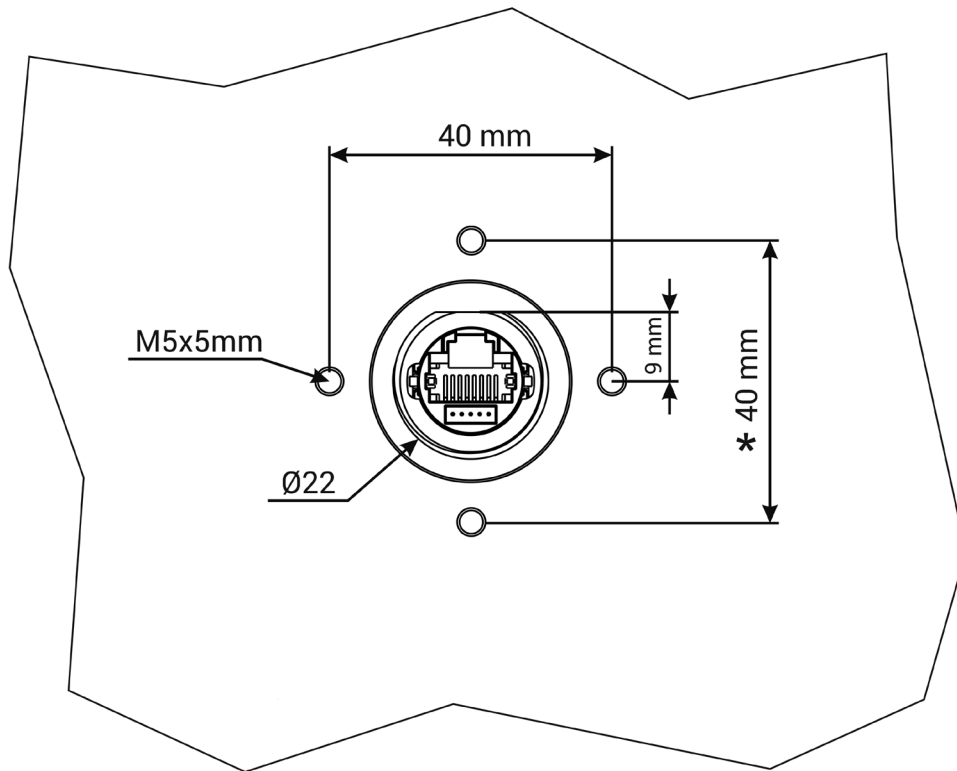

\* HMs715 and HMs721 only



## 10. Unpacking and packing instructions

HMs705, HMs707, HMs710

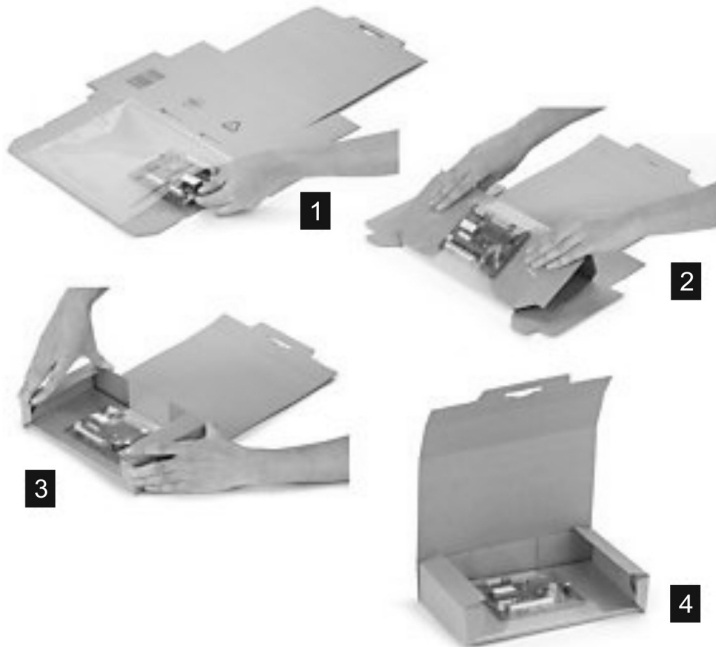

HMs715, HMs721

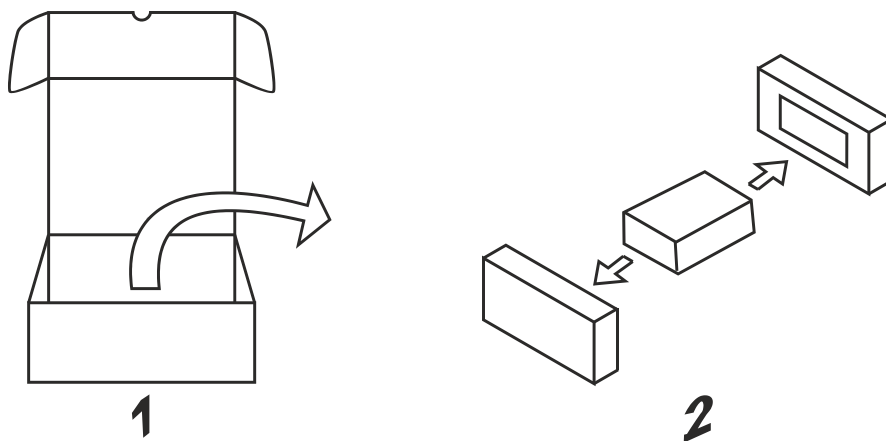

To repack the product, please follow the instructions backwards.

## 11. Installation

### 11.1 Installation environment

The product is not intended for continuous exposure to direct sunlight. There is a risk that the product might be overheating.

The product is not intended for installation in contact with corrosive chemical compounds. Check the resistance of the front panel film to a specific compound before installation.

Do not use tools of any kind (screwdrivers, etc.) to operate the touchscreen of the product.

IP67 is guaranteed only if:

- An appropriate cable (JSCAxxxx) is used. The cables JSCAU001, JSCAU002, JSCAU003 and JSCAU004 can be orderd as accessories.
- The max. deviation from the plane surface to the cutout is  $\leq 0.5\text{mm}$ .
- The thickness of the case where the product is mounted is from 1.5mm to 3mm.
- The max. surface roughness where the gasket is applied is  $\leq 120\mu\text{m}$ .

### 11.2 Installation procedure

For details on installation, please refer to the “Installation Guide” provided with the product.

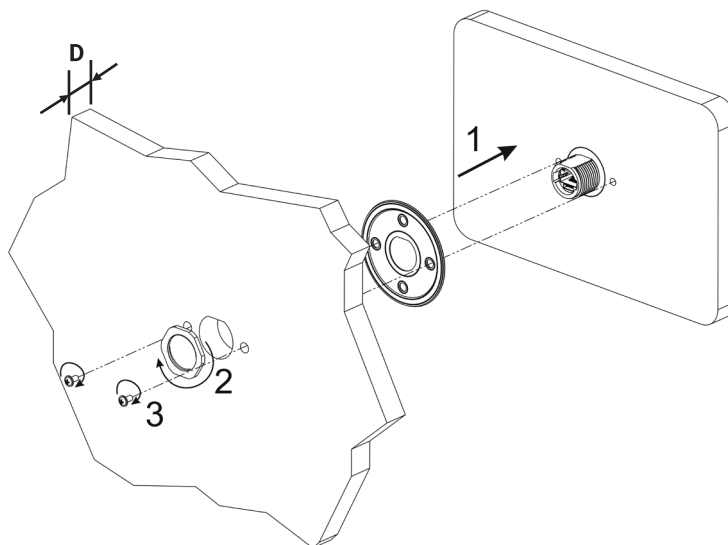

D	Cable
Max. 3mm	JSCAxxxx (IP67)
Max. 10mm	Standard Ethernet

#### ! Notice

Tightening torque: 1000Ncm (nut), 130Ncm (screws)

## 12. Connections

### 12.1 Ethernet port

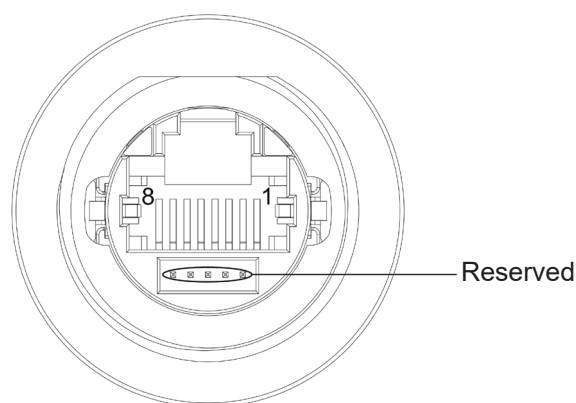

Pin	Description
1	TX+
2	TX-
3	RX+
4	n/c
5	n/c
6	RX-
7	n/c
8	n/c

The Ethernet port has two LED status indicators.

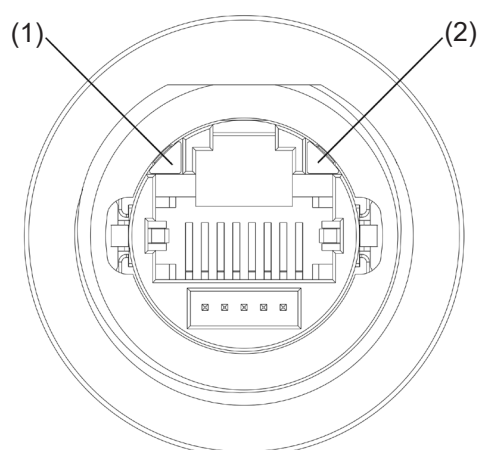

- (1) Red LED
  - Off: Valid link has not been detected
  - On: Valid link has been detected
- (2) Green LED
  - On: No activity
  - Flashes: Activity

### 12.2 Power supply, grounding, and shielding

The power is transmitted over a network cable (PoE).

#### NOTE

Make sure that the power supply has sufficient power capacity for the operation of the product.

The product must always be grounded to earth with a shielded network cable (CAT5 or higher). Grounding helps limit the effects of noise due to electromagnetic interference on the control system.

Earth connection can also be done using the screw located near the connector. A label identifies the ground connection.

All the electronic devices in the control system must be properly grounded. Grounding must be performed according to applicable regulations.

## 13. Battery

---

The touch terminals are equipped with rechargeable lithium batteries that are not user-replaceable. The battery is needed to keep the real-time clock running (date and time).

When the touch terminal is installed for the first time, the battery must be charged for 48 hours. When the battery is fully charged, data backup at 25°C is guaranteed for 3 months.

 This symbol indicates the battery location.

### HMs705

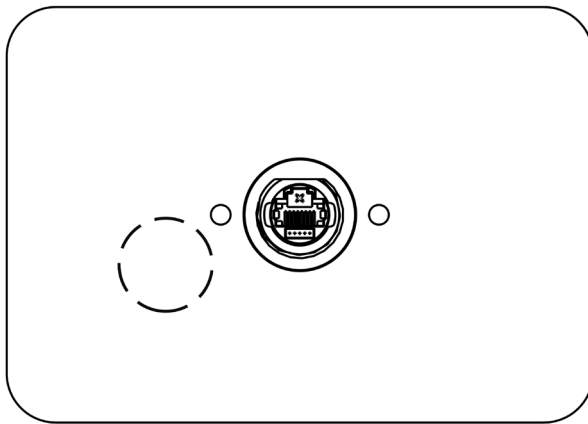

### HMs707

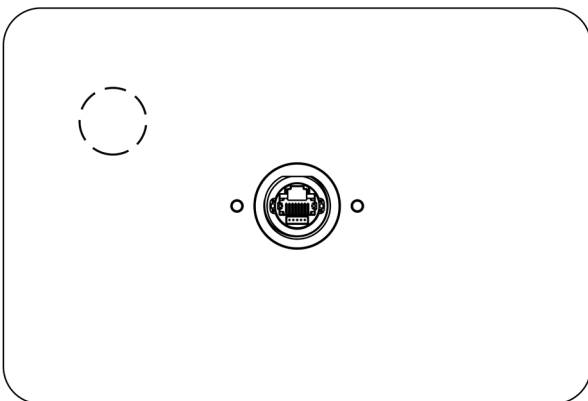

**HMs710**

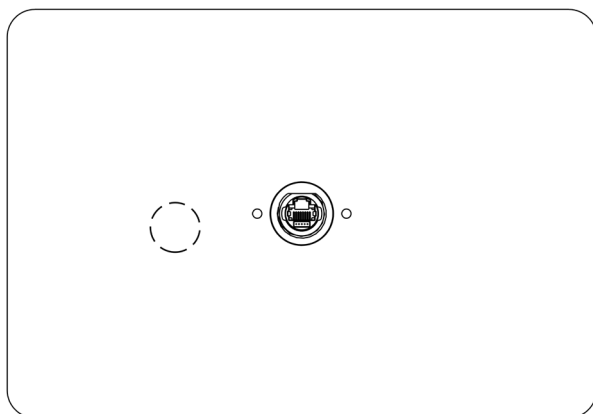

**HMs715**

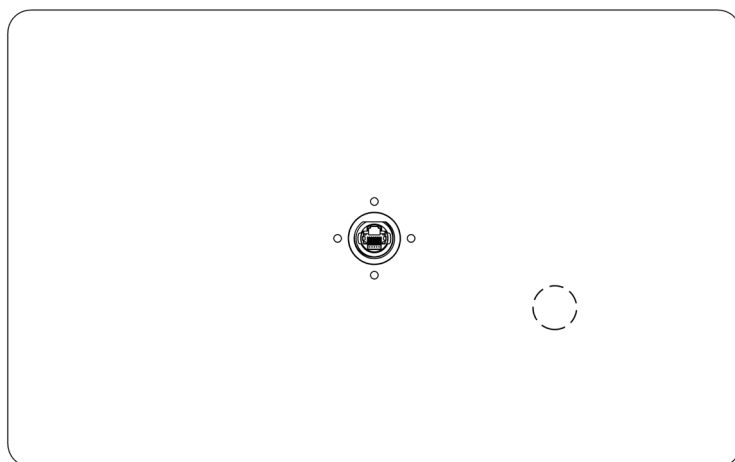

**HMs721**

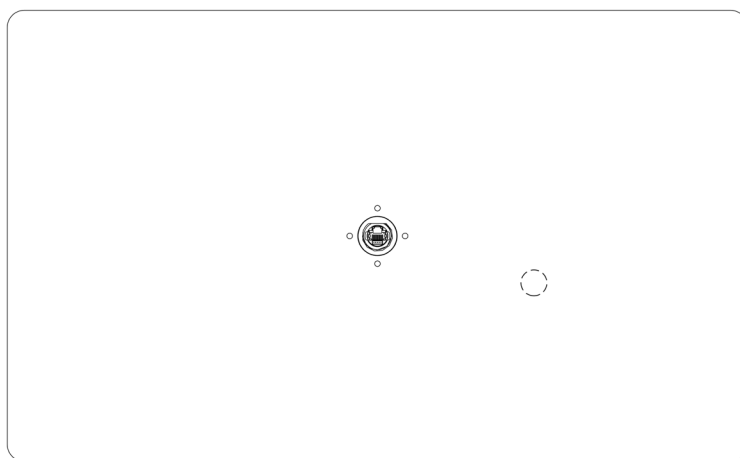

## 14. Getting started

---

The HMs700 series touch terminals must be programmed with the programming software HMWIN Studio (starting from v2.6), a Windows application.

There are two options to transfer an HMWIN application project to a touch terminal:

### Ethernet

Connect the touch terminal via the Ethernet interface to a personal computer running the HMWIN Studio software. Select “Run/Download to target” in HMWIN Studio.

Make sure that the firewall policy is configured in a way that allows HMWIN Studio to access the network.

### USB

Create an update package using the HMWIN Studio software and copy it to an USB flash drive. For USB transfer a dedicated accessory cable is required.

For more details about HMWIN Studio, refer to the help topics in the software.

## 15. Disposal

---



Used electrical and electronic products must not be placed in general household waste. For proper treatment, recovery and recycling of old products, take them to applicable collection points in accordance with your national legislation.

By disposing of them correctly, you will help to save valuable resources and prevent any potential negative effects on human health and the environment.

For more information about collection and recycling, please contact your local municipality.



Dispose of batteries according to local regulations.

## 16. Record of changes

---

ACGM0198V3EN, January 2023

- Updated the chapter “Standards and approvals”
- Deleted the chapter “System settings tool”
- Added the chapter “Product identification”
- Updated company name and back page
- Modified the manual design

ACGM0198V2EN, February 2021

- Added information about the appropriate cables (IP67)
- Added information about classification for HMs705

ACGM0198V1EN, December 2020

First edition

---

## **Panasonic Industry Europe GmbH**

Caroline-Herschel-Strasse 100, 85521 Ottobrunn, Germany  
+49 89 45354-1000  
<https://industry.panasonic.eu>

January, 2023