

Ultra-compact Laser / Class 1
Collimated Beam Sensor

HL-T1 Series

User's Manual

[Applicable model]

For controller software Ver.3

Thank you for purchasing the ultra-compact laser collimated sensor **HL-T1** series. In order to realize the full potential of the outstanding performance of this product, please read this USER'S MANUAL thoroughly and determine the optimum methods for correct use.

This product undergoes a rigorous inspection before being shipped, but be sure, before attempting to use it, please perform an operation check to assure that there is no damage or defects that may have occurred during shipping. In the unlikely event that damage is found, or in the case that this product does not operate in accordance with specifications, please contact the retail shop where you purchased it, or this company's business office.

■ Precautions

1. This product has been developed / produced for industrial use only.
2. The pictures included in this USER'S MANUAL may differ slightly from the actual product. Please understand this in advance.
3. The contents of this USER'S MANUAL are subject to change without notice due to future improvements.
4. Unauthorized reproduction or transfer of this USER'S MANUAL and accompanying software, in part or in whole, is prohibited.
5. We have done our utmost to make this USER'S MANUAL as perfect and complete as possible, but any points which are doubtful or in error, or if there are any pages that are improperly arranged or missing, please take the trouble to contact our nearest business office.
6. Regardless of item 3 above, please understand that this company shall not accept any liability concerning the results of this product's operation.

WARRANTY

[Warranty Period]

- Unless otherwise agreed, Panasonic Industrial Devices SUNX warrants this product for twelve (12) months from the date of the shipment or delivery to the purchaser's appointed warehouse. However, note that consumables of the product, such as batteries or lamps etc. are not covered.

[Scope of Warranty]

- During the above mentioned period, if a failure of the product occurs under normal use and operation, and if Panasonic Industrial Devices SUNX determines that it is responsible for the failure, it shall repair the defect or replace the product.

However, in no event shall Panasonic Industrial Devices SUNX be liable for the failure, damage or loss stipulated below:

- (1) Failure caused by instructions, standards, or handling specified by the customer.
- (2) Failure caused by modifications done in the structure, capabilities, specifications, etc., without consulting Panasonic Industrial Devices SUNX, after the purchase or the delivery of the product.
- (3) Failure caused by a development which could not be foreseen based upon the technology in proactive at the time of purchase or contract.
- (4) Failure caused by use which deviates from the conditions / environment given in the product catalog or specifications.
- (5) In case this product is used by being incorporated in the customer's machine, failure which could be avoided if the customer's machine had functions and structure commonly accepted in the industry.
- (6) Failure due to Force Majeure.

Further, the warranty given here is limited only to this product which has been purchased or delivered. Panasonic Industrial Devices SUNX shall not be responsible for any consequential damage or loss arising out of the failure of this product.

[Scope of Service]

The cost of the delivered product does not include the cost of dispatching an engineer, etc. In case any such service is needed, it should be separately requested.

CHAPTER 1 FOR PERSONS WHO WANT TO USE THE PRODUCT RIGHT AWAY

Explains connections, wiring and the settings that are necessary for those who want to use the product right away.

CHAPTER 2 BEFORE USE

Explains the preparations necessary before turning on the power, such as giving an outline of the product and installing, connecting and wiring it, etc., and explains the settings to be made when the power is first turned on.

CHAPTER 3 EXPLANATION OF FUNCTIONS

Provides an outline of the functions and their operation, and gives an explanation concerning the functions that can be set and setting methods.

CHAPTER 4 ERRORS: WHEN THIS HAPPENS...

Explains concerning the indications and treatment, etc. when each type of error occurs.

CHAPTER 5 SPECIFICATIONS AND DIMENSIONS

Explains concerning ratings and performance.

CONTENTS

In order to use this product safely	8
About Laser Safety	9
1. JIS / IEC/GB	9
2. FDA.....	11
Handling Precautions	16
Checking the Package Contents.....	18
About Markings.....	19
List of controller LED display characters	20
When this happens... ..	22
CHAPTER 1 FOR PERSONS WHO WANT TO USE THE PRODUCT RIGHT AWAY	25
1.1 For Persons Who Want To Use The Product Right Away.....	26
1.2 Connecting The Sensor Head And Controller	27
1.3 Laser Beam Alignment.....	29
1.4 Setting Auto Scaling.....	30
1.5 Setting The Standard Laser Beam Reception Intensity	32
1.6 Setting The Linear Output.....	33
1.7 Setting The Judgment Output	35
1.8 Starting Measurement	37
CHAPTER 2 BEFORE USE	39
2.1 Laser Collimated Sensor.....	40
2.1.1 Outline of the HL-T1 series	40
2.1.2 Sensor head.....	41
2.1.3 Controller.....	41
2.1.4 Calculation unit.....	41
2.2 Parts Description	42
2.2.1 Sensor head.....	42
2.2.2 Controller (optional).....	43
2.2.3 Calculation unit (optional).....	44
2.2.4 Controller CH No.	44
2.3 External Inputs and Outputs.....	45
2.3.1 Input / output lines	45
2.3.2 Inputs.....	46
2.3.3 Outputs.....	48
2.4 Input / Output Circuit Diagrams	50
2.4.1 NPN output type (HL-AC1).....	50
2.4.2 PNP output type (HL-AC1P)	51
2.5 Mounting Method.....	52
2.5.1 Sensor head.....	52
2.5.2 Controller.....	54

2.6	Connections	55
2.6.1	Connection cable to controller	55
2.6.2	Connection cable to sensor head	55
2.6.3	Cable extension	56
2.6.4	Controller to calculation unit	57
2.7	Laser Beam Alignment	58
2.8	Setting Auto Scaling	59
2.9	Setting the Standard Laser Beam Reception Intensity	62
CHAPTER 3 EXPLANATION OF FUNCTIONS		63
3.1	Outline of Display Operations	66
3.1.1	Operating face	66
3.1.2	Outline of indicators	67
3.1.3	Outline of operating switches	68
3.2	Outline of Functions	69
3.2.1	RUN mode	69
3.2.2	THR mode	69
3.2.3	FUN mode	69
	■ Status transition chart in the FUN mode	70
	■ Here the procedure for scaling settings is shown	71
	■ Here the procedure for setting related SEt settings is shown	72
	■ Here the procedure for performing display related dISP settings is shown	73
	■ Here the procedure for other EtC settings is shown	73
	■ Here the procedure for the auto scaling setting is shown	73
3.3	List of Default Setting Values	74
3.4	Display at Startup	75
3.5	RUN Mode	76
3.5.1	Basic operation	76
3.5.2	Changing the sub-digital display	76
	■ Threshold value display	77
	■ Voltage value display	77
	■ Current value display	77
	■ Laser beam reception intensity display	78
	■ Resolution display	78
	■ Current value display	78
3.5.3	Zero reset / cancellation	79
3.5.4	Setting the standard laser beam reception intensity	83
3.5.5	Other functions in the RUN mode	84
	■ Timing input	84
3.6	THR (Threshold) Mode	85
3.6.1	Direct threshold value input	86
	■ Changing the numerical value	86
	■ Fixing the numerical value	87
3.6.2	Teaching	88
3.6.3	Teaching positioning	88
	■ Example of teaching positioning	88
3.6.4	2-point teaching	90
	■ Example of 2-point teaching	90

3.6.5	Automatic teaching	93
	■ Example of automatic teaching	93
3.7	FUN (Function) Mode	96
3.7.1	Basic operation	96
3.7.2	Basics of mode changes	96
3.7.3	Changing setting values (other than numerical values)	97
3.7.4	Changing setting values (in case of numerical values)	99
	■ Setting the numerical value (when normal)	100
	■ Setting the numerical value (when abnormal)	100
3.8	Functions That Can Be Set In The FUN Mode	102
3.8.1	Auto scaling function	102
3.8.2	Scaling function	104
	■ If you desire to offset the display value	107
	■ If you desire to correct the display value to the actual width	108
	■ If you desire to use the desired display value	108
3.8.3	Average sampling rate	111
3.8.4	Hysteresis width setting	112
	■ Direct input	112
	■ Auto hysteresis setting	112
3.8.5	Hold	113
	■ Normal (no hold): off	114
	■ Peak hold: P-h	115
	■ Bottom hold: b-h	116
	■ Sample hold: S-h	117
	■ Peak to peak hold: PP-h	118
	■ Average hold: Ave-h	119
	■ Peak hold + Self-up trigger	123
	■ Peak hold + Self-down trigger	124
	■ Judgment outputs while the hold mode is in use	125
	■ Setting Delay Time	126
3.8.6	Timer	129
	■ Timer period	129
	■ Without timer	129
	■ OFFdelay timer	129
	■ ON delay timer	129
	■ ONE SHOT timer	129
3.8.7	Adjacent sensor calculation	132
	■ A-B	132
	■ A+B	132
	■ THICK	132
	■ Calculation results output	132
3.8.8	Adjacent calculation THICK (Thickness measurement)	134
3.8.9	Setting initialization	138
3.8.10	Monitor focus function	140
3.8.11	Linear output correction	144
3.8.12	Differential function	148
3.8.13	Previous value comparison	150
3.8.14	Display reverse function	153

3.8.15	ECO display function	154
3.8.16	Display digits limitation	155
3.8.17	Non-measuring time setting	156
3.8.18	Zero reset memory function	158
3.8.19	Gain switching	159
3.8.20	Key lock function.....	160
CHAPTER 4	ERRORS: WHEN THIS HAPPENS...	161
4.1	Errors: When This Happens...	162
4.1.1	Error display during normal measurement	162
4.1.2	Error display when setting numerical values.....	163
4.1.3	Error display during adjacent sensor calculation	163
4.1.4	Scaling cannot be set.	164
4.1.5	Monitor focus cannot be set.....	164
4.1.6	Threshold values cannot be set	164
4.1.7	Hysteresis cannot be set.	164
4.1.8	Laser deterioration.....	164
CHAPTER 5	SPECIFICATIONS AND DIMENSIONS	165
5.1	Ratings / Performance	166
5.1.1	Sensor head	166
5.1.2	Sensor head (FDA compatible).....	167
5.1.3	Controller	168
5.1.4	Calculation unit	170
5.2	Dimensions	171
5.2.1	Sensor head	171
	■HL-T1001A [φ 1mm type]	171
	■HL-T1001F [φ 1mm type].....	172
	■HL-T1001□ [Dimensions with side view attachment (HL-T1SV1)].....	173
	■HL-T1005A [5mm type].....	174
	■HL-T1005F [5mm type]	175
	■HL-T1005□ [Dimensions with side view attachment (HL-T1SV1)].....	176
	■HL-T1010A [10mm type]	177
	■HL-T1010F [10mm type]	178
	■HL-T1010□ [Dimensions with side view attachment (HL-T1SV2)].....	179
	■MS-HLT1-1 [Sensor head mounting bracket for HL-T1001□ / HL-T1005□]	180
	■MS-LA3-1 [Sensor head mounting bracket for HL-T1010□]	181
	■CN-HLT1-1 [Sensor head to controller connection cable]	182
5.2.2	Controller	183
	■HL-AC1 / HL-AC1P	183
	■MS-HLAC1-1 [Controller mounting bracket]	184
5.2.3	Calculation unit	185
	■HL-AC1-CL	185
5.3	INTENDED PRODUCTS FOR CE MARKING	186
APPENDIX	187
FUNCTION INDEX	188

In order to use this product safely

● Indications affixed to assure safe use and their meaning.

In order that you may use the laser collimated sensor safely, this USER'S MANUAL includes the following indications and graphic symbols.

The caution items shown in this manual highlight contents which are extremely important for safety.

 **WARNING**

Shows warnings concerning items, places or conditions where there is danger or concern with the safety of the human body.

● **Explanation of Graphic Symbols**



● **Laser Beam**

A warning that there is the possibility of danger from a laser beam.

 **WARNING**

This product is equivalent to a JIS / IEC Standard Class 1 Laser device. Essentially, it is safe, but it is dangerous to view the laser beam through a lens or other optical observation system, so please avoid doing so.



About Laser Safety

1. JIS / IEC/GB

● With the objective of preventing injury to users of laser products before it can happen, JIS C 6802-2014, "Safety Standard for Laser Products", based on IEC (International Electrical Standards Committee) standards, was stipulated. In JIS C 6802-2014, laser products are divided into classes corresponding to the degree of danger of the laser component, and preventive measures to assure safety which should be taken with each class are stipulated.

This product is regarded as Class 1 laser product not only by JIS C 6802-2014 "Safety Standard for Laser Products" but also by IEC 60825-1-2014 and EN 60825-1-2014.

● Class Categorization of the HL-T1 □□□ A. (JIS / IEC/GB)

Class 1

• Laser Related Label Indications

The following label is affixed to a side of sensor head according to the laser device safety standard.

- When this product is used in China, replace the Chinese label.

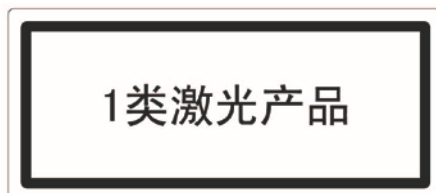

 **WARNING**

This product is equivalent to a JIS / IEC Standard Class 1 laser product. It is essentially safe, but viewing of the laser light through a lens or other optical viewing device is dangerous, so avoid doing so.



2. FDA

● About Export to the United States

If this product is exported to the US as a component of a machine or instrument, it is governed by the regulations for laser standards of the FDA (Food and Drug Administration). Use a device which complies with FDA standards.

The models which comply with FDA standards are as follows.

<p>HL-T1001F HL-T1005F HL-T1010F</p>

- With the objective of preventing the occurrence of injuries to persons using laser products before they happen, the FDA (Food and Drug Administration) has stipulated the following standard.

Part 1040 (PERFORMANCE STANDARDS FOR LIGHT-EMITTING PRODUCTS)

- In this standard, laser products are classified in accordance with the degree of danger of the laser, and preventive safety measures have been stipulated which should be executed for each class. (See the list of required items for laser products.)

This product is classified under this standard as follows.

HL-T1 □ □ □ F Classification (FDA)

<p>Class 2</p>

- The following label is affixed to this product based on the FDA standard.

(1) Aperture Label

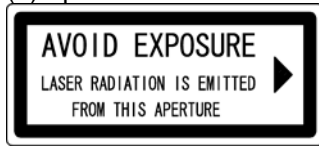

(2) Warning Label

(for the HL-T1001F)

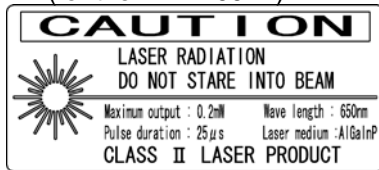

(For the HL-T1005F, HL-T1010F)

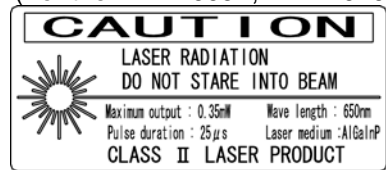

(3) Protective Housing Label (4) Certification and Identification Label

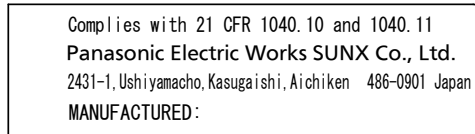

<Label Position>

HL-T1001F, HL-T1005F

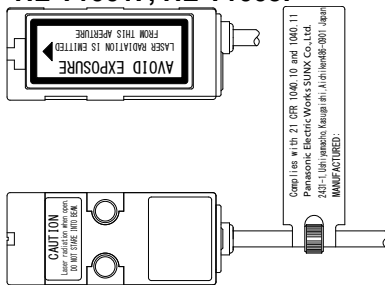

HL-T1010F

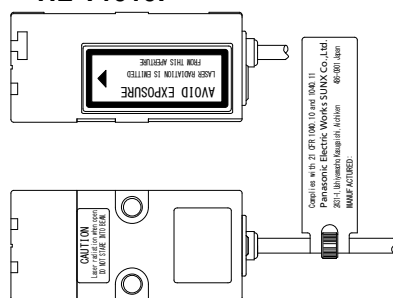

(Note 1): The label shown above is for the HL-T1001F.

- **Laser Beam Attenuator**

In case there may be a hazard that the eye can be exposed to the laser beam while working, fit the laser beam attenuator, provided as accessory, on the aperture of laser radiation.

- **Laser Beam Indicator**

While the laser beam is being emitted, a green LED on the sensor head lights up.

This LED can be checked even through the laser protective glass.

● **Table of FDA Requirements for Laser Products**

Requirements	Class					
	I	IIa	II	IIIa	IIIb	IV
<u>Performance (all laser products)</u>						
Protective housing [1040.10 (f) (1)]	R ²	R ²	R ²	R ²	R ²	R ²
Safety interlock [1040.10 (f) (2)]	R ^{3,4}	R ^{3,4}	R ^{3,4}	R ^{3,4}	R ^{3,4}	R ^{3,4}
Location of controls [1040.10 (f) (7)]	N/A	R	R	R	R	R
Viewing optics [1040.10 (f) (8)]	R	R	R	R	R	R
Scanning safeguard [1040.10 (f) (9)]	R	R	R	R	R	R
<u>Performance (laser systems)</u>						
Remote control connector [1040.10 (f) (3)]	N/A	N/A	N/A	N/A	R	R
Key control [1040.10 (f) (4)]	N/A	N/A	N/A	N/A	R	R
Emission indicator [1040.10 (f) (5)]	N/A	N/A	R	R	R ¹⁰	R ¹⁰
Beam attenuator [1040.10 (f) (6)]	N/A	N/A	R	R	R	R
Reset [1040.10 (f) (10)]	N/A	N/A	N/A	N/A	N/A	R ¹³
<u>Performance (specific-purpose products)</u>						
Medical [1040.11 (a)]	S	S	S	S ⁸	S ⁸	S ⁸
Surveying, leveling, alignment [1040.11 (b)]	S	S	S	S	NP	NP
Demonstration [1040.11 (c)]	S	S	S	S	S ¹¹	S ¹¹
<u>Labeling (all laser products)</u>						
Certification & identification [1010.2, .3]	R	R	R	R	R	R
Protective housing [1040.10 (g) (6), (7)]	D ⁵	R ⁵	R ⁵	R ⁵	R ⁵	R ⁵
Aperture [1040.10 (g) (4)]	N/A	N/A	R	R	R	R
Class warning [1040.10 (g) (1), (2), (3)]	N/A	R ⁶	R ⁷	R ⁹	R ¹²	R ¹²
<u>Information (all laser products)</u>						
User information [1040.10 (h) (1)]	R	R	R	R	R	R
Product literature [1040.10 (h) (2) (i)]	N/A	R	R	R	R	R
Service information [1040.10 (h) (2) (ii)]	R	R	R	R	R	R

Legend

R - Required

N/A - Not applicable

S - Requirements : Same as for other products of that Class. Also see footnotes.

NP - Not permitted

D - Depends on level of interior radiation

Footnotes

- 1 Based on highest level accessible during operation.
- 2 Required wherever & whenever human access to laser radiation above Class 1 limits is not needed for product to perform its function.
- 3 Required for protective housing opened during operation or maintenance, if human access thus gained is not always necessary when housing is open.
- 4 Interlock requirements vary according to Class of internal radiation.
- 5 Wording depends on level & wavelength of laser radiation within protective housing.
- 6 Warning statement label.
- 7 CAUTION logotype.
- 8 Requires means to measure level of laser radiation intended to irradiate the body.
- 9 CAUTION if 2.5 mW cm⁻² or less, DANGER if greater than 2.5 mW cm⁻².
- 10 Delay required between indication & emission.
- 11 Variance required for Class IIIb or IV demonstration laser products and light shows.
- 12 DANGER logotype.
- 13 Required after August 20, 1986.

● Export to foreign countries other than the US and use.

In the case of export to areas other than the US or use in those areas, replace the label on the model that complies to the FDA standards, the HL-T1 □□□F, with the supplied label.

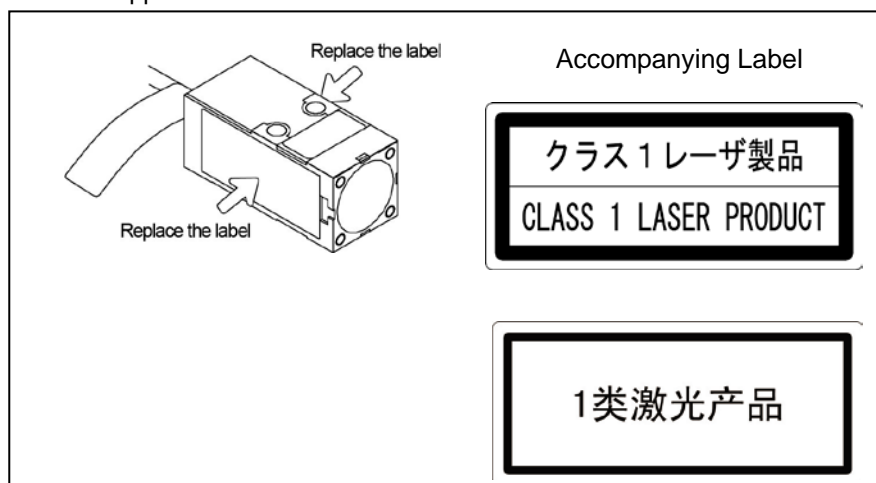

Handling Precautions

WARNING

- Never use this product as a sensing device for personnel protection.
- In case of using sensing devices for personnel protection, use products which meet laws and standards, such as OSHA, ANSI or IEC etc., for personnel protection applicable in each region or country.

Connection

- This product is made to satisfy the specifications when the sensor head is combined with the controller. In any other combination, not only may it not satisfy the specifications, but could be the cause of breakdown, so by all means, use it so that there is a combination of the sensor head and controller.
- Installation of the sensor head and controller, and their removal, must always be performed with the controller's power turned off.
- If the cables are pulled, it could cause the wires in the cable to become disconnected, so exercise caution.

Power Supply

- Use this product 10min. after the power is supplied. Immediately on supply of power, the electrical circuit has yet to stabilize, which may cause variation in measured values.
- After turning on the power, there is a muting period of approximately 5 sec., so exercise caution.
- Take care that the wrong wiring may damage the sensor.
- Verify that the supply voltage variation is within the rating.
- If power is supplied from a commercial switching regulator, ensure that the frame ground (F.G.) terminal of the power supply is connected to an actual ground.
- Make sure to use an isolation transformer for the DC power supply. If an auto-transformer (single winding transformer) is used, this product or the power supply may get damaged.
- In case a surge is generated in the used power supply, connect a surge absorber to the supply and absorb the surge.

Wiring

- Do not run the wires together with high-voltage lines or power lines or put them in the same raceway. This can cause malfunction due to induction.
- Make sure to carry out the wiring in the power supply off condition.
- The linear output is not equipped with a protective circuit against short circuits. Do not connect the power supply or capacity load directly.
- When using the calculation unit, connect the mutual controller's linear GND.
- Be careful not to apply static electricity to the connector during wiring. Doing so could cause breakdown.

- Extend the cable between the sensor head and the controller using the exclusive cable, and keep the total length to within 10 meters. Be sure to use the exclusive extension cable (**HL-T1CCJ**□) to extend the cable from the sensor head. Use the same type of shielded cable for wiring from the controller.

Environment

- Avoid dust, dirt, and steam.
- Take care that the sensor does not come in direct contact with water, oil, grease, or organic solvents, such as, thinner, etc.
- In case noise generating equipment (switching regulator, inverter motor, etc.) is used in the vicinity of this product, connect the frame ground (F.G.) terminal of the equipment to an actual ground.
- Do not allow any water, oil, fingerprints, etc., which may refract light, or dust, dirt, etc., which may block light, to stick to the emitting/receiving surfaces of the sensor head. In case they are present, wipe them with a clean, soft cloth or lens paper.
- Prevent sunlight or light of the same wavelength or other interfering light from shining on the sensor head's light receiver. In cases where particular accuracy is required, install a shade plate, etc. so that the interference light will not strike the sensor head.
- If the regular reflection light from the workpiece is strong, such as in the case of a glass or mirror-surface item, the reflection light may disallow proper detection. In such a case, adjust the mounting angle so that the reflection light does not enter the emitter or receiver.
- When the sensor is mounted, stress should not be applied to the sensor cable joint and the connector part.
- This sensor is suitable for indoor use only.
- Avoid use at places subject to intense vibrations or shock.

Interchangeability

- The sensor head and controller are interchangeable. It is also possible to replace only the sensor head.

Mutual Interference

- Mutual interference can be prevented during use by using the sensor head and controller with a calculation unit (**HL-AC1-CL**) connected between them.

Display Values

- This product outputs the judgment of the laser light analog quantity. Since there is variation in the light intensity between the center and the edges of the detection area, and emitter side and the receptor side, the "display value" does not equal "the actual dimensions", so caution is necessary. Use the displayed dimensional value as a criterion.

Other

- Absolutely do not attempt to disassemble this product.

Checking the Package Contents

Before using this product, check if the following items have been included in the package.

Sensor Head

- Body: Emitter, receiver 1 pc. each
- Sensor head-controller connection cable 1 pc.
- Sensor head mounting bracket set 2 sets
(Sensor head mounting brackets: 1 pc., M3 screws: 2 pcs., Nut: 1 pc.)
- Light beam alignment stickers 2 pcs.
- Label set (HL-T1 □□□ F only) 1 set
- Chinese laser class label set 1 set
- Instruction Manual 1 pc.

Controller (optional)

- Controller Unit 1 pc.

Calculation Unit (optional)

- Calculation Unit 1 pc.

About Markings

■ Meanings of Symbols



Shows an item that it would convenient to know.



Shows an item about which caution is necessary during operation.



Shows the item number of related contents in the manual.

List of controller LED display characters

A	b	c	d	E	F	G	h	I	J
R	b	c	d	E	F	G	h	I	J
K	L	m	n	o	P	q	r	S	t
P	L	n	n	o	P	q	r	S	t
U	v	w	X	Y	Z				
U	u	y	u	y	z				

Memo

When this happens...

- When desiring to set the judgment output threshold value directly.
Reference»» '3.6.1 Direct threshold value input'
- When desiring to teach workpiece positioning.
Reference»» '3.6.3 Teaching positioning'
- When desiring to teach judgment of workpieces for which the dimensions are unknown.
Reference»» '3.6.4 2-point teaching'
- When desiring to teach judgment of workpieces with an uneven or warped surface or workpieces in motion.
Reference»» '3.6.5 Automatic teaching'
- When desiring to set the standard light reception intensity.
Reference»» '3.5.4 Setting the standard laser beam reception intensity'
- When desiring to change the digital display value freely.
Reference»» '3.8.1 Auto scaling function', '3.8.2 Scaling function'
- When desiring to change the response speed or raise the resolution.
Reference»» '3.8.3 Average sampling rate'
- When desiring to change the positioning accuracy during operation and during reset.
Reference»» '3.8.4 Hysteresis width setting'
- When desiring to hold the value measured during measuring.
Reference»» '3.8.5 Hold'
- When desiring to use the off delay timer
Reference»» '3.8.6 Timer'
- When desiring to connect and calculate using 2 sensor heads.
Reference»» '3.8.7 Adjacent sensor calculation'
- When desiring to measure the thickness using two sensor heads.
Reference»» '3.8.8 Adjacent Calculation THICK (Thickness Measurement)'

- When desiring to return to the factory settings.
Reference»» '3.8.9 Setting initialization'
- When desiring to change the output current and voltage range.
Reference»» '3.8.10 Monitor focus function'
- When desiring to correct linear output values.
Reference»» '3.8.11 Linear output correction'
- When desiring to detect minute changes.
Reference»» '3.8.12 Differential function'
- When desiring to detect sudden changes.
Reference»» '3.8.13 Previous value comparison'
- When desiring to reverse the display direction.
Reference»» '3.8.14 Display reverse function'
- When desiring to reduce controller current consumption, even if by only a little.
Reference»» '3.8.15 ECO display function'
- When desiring to temporarily stop the laser output.
Reference»» '2.3.2 Inputs' (Laser OFF when LD-OFF is input)
- When desiring to change the number of columns in the digital display.
Reference»» '3.8.16 Display digits limitation'
- When desiring to make settings freely when measurements cannot be made.
Reference»» '3.8.17 Non-measuring time setting'
- When desiring to carry out zero reset each time a workpiece is measured.
Reference»» '3.5.3 Zero reset / Cancellation'
 '3.8.18 Zero reset memory function'
- When desiring to set the receptor sensitivity freely.
Reference»» '3.8.19 Gain switching'

- When desiring to avoid settings by careless operations.

Reference▶▶ '3.8.20 Key lock function'

CHAPTER 1

FOR PERSONS WHO WANT TO USE THE PRODUCT RIGHT AWAY

Explains connections, wiring and the settings that are necessary for those who want to use the product right away.

1.1	For Persons Who Want To Use The Product Right Away	26
1.2	Connecting The Sensor Head And Controller	27
1.3	Laser Beam Alignment.....	29
1.4	Setting Auto Scaling	30
1.5	Setting The Standard Laser Beam Reception Intensity	32
1.6	Setting The Linear Output.....	33
1.7	Setting The Judgment Output.....	35
1.8	Starting Measurement.....	37

1.1 For Persons Who Want To Use The Product Right Away

For persons who want to use this product right away, carry out settings by the procedure shown below.

- 1.2 **Connecting The Sensor Head And Controller**
- 1.3 **Laser Beam Alignment**
- 1.4 **Setting Auto Scaling**
- 1.5 **Setting The Standard Laser Reception Intensity**
- 1.6 **Setting The Linear Output**
- 1.7 **Setting The Judgment Output**
- 1.8 **Starting Measurement**

After adjusting the light beam, be sure to perform the auto scaling setting before carrying out the other settings.

Please

If the auto scaling function is set, all the settings return to the default values set at the time of factory shipment, so exercise caution.

1.2 Connecting The Sensor Head And Controller

Connect the sensor head and controller by the following procedure, connect the power supply, then turn it on.

(1) Connection cable and controller

Insert the controller connection connector on the connection cable with the controller's input cable connector, inserting it until the ring on the outside of the connector locks.

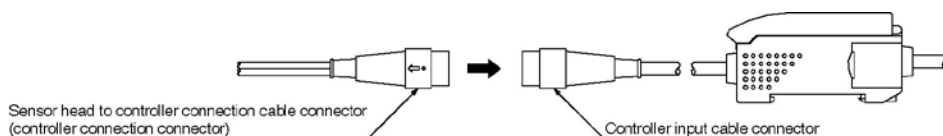

(2) Connection cable and sensor head

Insert the connection cable's sensor head connection connectors in the emitter / receiver connectors until their claws lock in the grooves of the emitter / receiver connectors.

Connect the emitter side to the connector with a gray cable and connect the receiver side to the connector with a black cable.

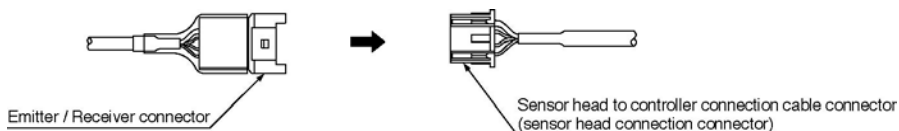

(3) The antistatic cover has been fitted on the connection cable.

After connecting the sensor head and connection cable, be sure to cover the connector with the anti-static cover.

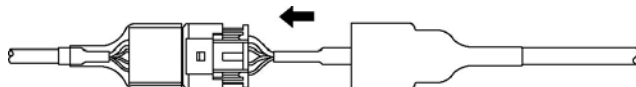

(4) Connect the power supply to the controller, then turn on the power.

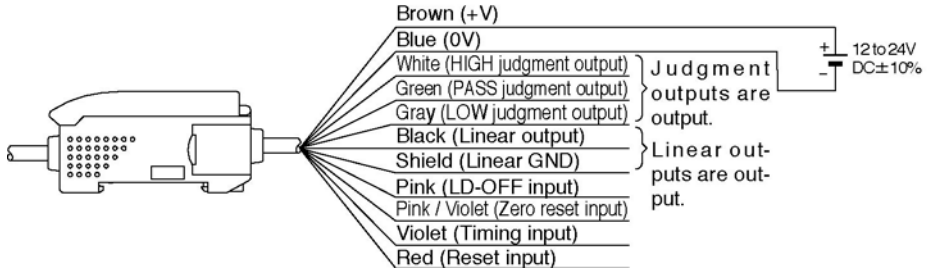

(5) When the power is turned on, the following screen is displayed in the controller.

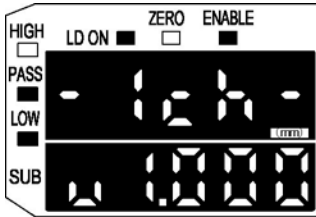

In some cases, the version will be changed.

The controller's format is displayed in the top row and the number of channels is displayed after that.

The software version is displayed on the bottom row. Operation switches to normal operation after this information is displayed for 3 seconds.

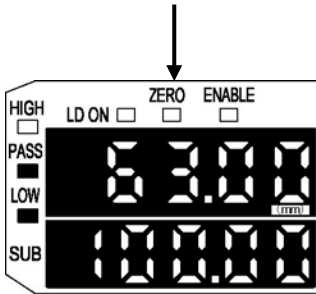

This example shows the display in the case that the mode select switch is in the RUN position.

The numbers shown in the display are display examples.

1.3 Laser Beam Alignment

Align the laser beam.

- (1) Install the emitter and receiver.

The laser beam has directivity, so be careful of the installation direction of the emitter and receiver.

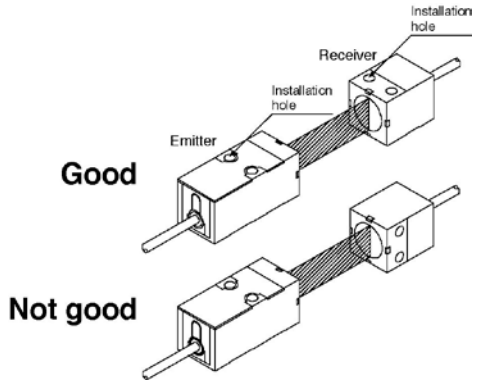

- (2) Affix the laser beam alignment sticker supplied to the front of the receiver and adjust the emitter and receiver so that the emitted beam strikes the center of the cross marks.

After adjustment, be sure to remove the sticker.

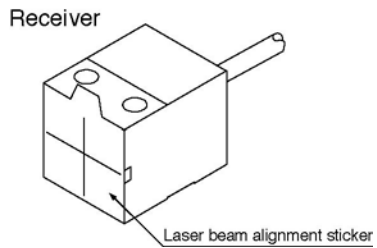

Please

If the regular reflection light from the workpiece is strong, such as in the case of a glass or mirror-surface item, the reflection light may disallow proper detection. In such a case, adjust the mounting angle so that the reflection light does not enter the emitter or receiver.

1.4 Setting Auto Scaling

Select whether the measurement results will be displayed in the main digital display in mm units or in % units, and whether the intensity of laser beam received or the intensity of laser beam interrupted is displayed.

■ Setting example of each sensor head

Sensor head	Detection width	Intensity of laser beam received / interrupted display	Auto scaling setting	Operation		
				Output operation	Display	Linear output
HL-T1005A HL-T1005F	5mm	Intensity of laser beam received display	5-L	When full laser beam is received	5mm	+4V
				When full laser beam is interrupted	0mm	-4V
		Intensity of laser beam interrupted display	5-d	When full laser beam is received	0mm	-4V
				When full laser beam is interrupted	5mm	+4V
HL-T1010A HL-T1010F	10mm	Intensity of laser beam received display	10-L	When full laser beam is received	10mm	+4V
				When full laser beam is interrupted	0mm	-4V
		Intensity of laser beam interrupted display	10-d	When full laser beam is received	0mm	-4V
				When full laser beam is interrupted	10mm	+4V
HL-T1001A HL-T1001F	∅1mm	Intensity of laser beam received display	100-L	When full laser beam is received	100%	+4V
				When full laser beam is interrupted	0%	-4V
		Intensity of laser beam interrupted display	100-d	When full laser beam is received	0%	-4V
				When full laser beam is interrupted	100%	+4V

Note: The linear output is an example of the default in the case of voltage output.

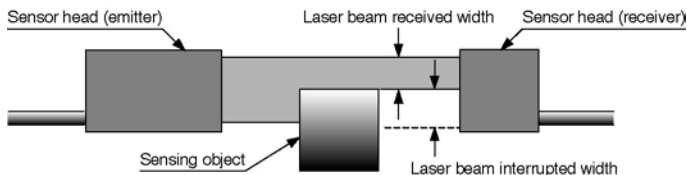

- If you desire to measure the width of laser beam received, select " -L".
- If you desire to measure the width of laser beam interrupted, select "-d".

■ Setting Method

(1) Set the Mode Select switch on 'FUN'.



(2) Display 'AutoS' using the LEFT / RIGHT key (◀/▶).

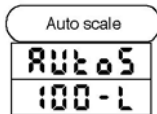

(3) Select the contents using the UP / DOWN key (▲/▼).

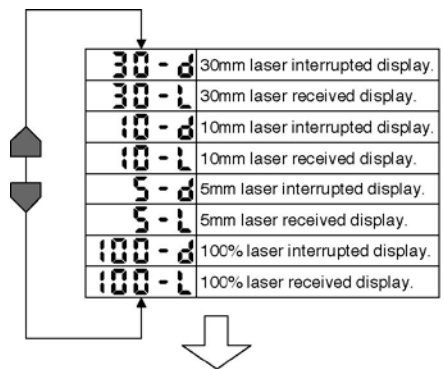

(4) Fix the selecting using the ENT key (■).

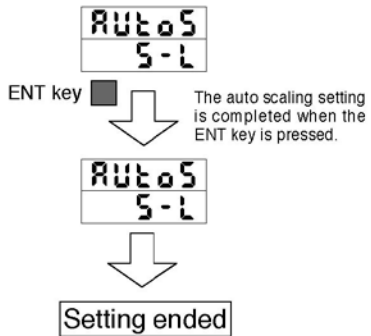

※ The display in the illustration is a setting example.

(5) Set the mode select switch in the 'RUN' position, then return to the measurement state.

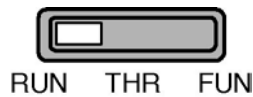

Please

When auto scaling is set, all the settings are automatically returned to the default values set at the factory, so exercise caution.
The standard light reception amount is also canceled, so be sure to reset it.

1.5 Setting The Standard Laser Beam Reception Intensity

With the sensor head installed, set the laser reception intensity as the standard laser beam reception intensity.

■ Setting method

(1) Set the mode select switch in the 'RUN' position.



(2) Set the state where full the laser beam received.

RUN THR FUN

(3) Press the DOWN key for 3 seconds or more.

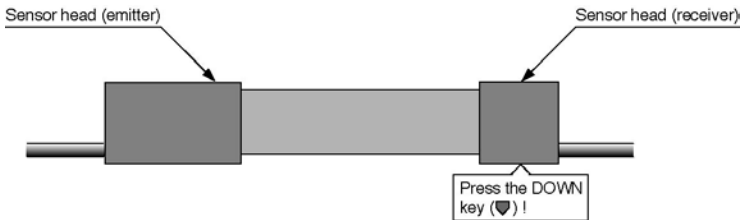

(4) If the setting was done correctly, it will be near the value set by the auto scaling setting.

Example; If 100-L was set, it will be near 100.00.

If 100-d was set, it will be near 0.00.

If the value is not near the set value, it is not set correctly.

Adjust the laser beam again.

Please

Be sure to perform the standard laser reception intensity setting after the power has been switched on for 10 minutes or more and the display values have stabilized.



At a time when you are not setting the standard laser reception intensity, the value in the main digital display will not be a value near the full scale (F.S.) value, even if the light beam is striking the receiver normally. It will be a value that is smaller than the full scale (F.S.) value.

1.6 Setting The Linear Output

Set the linear output in the setting at the time of factory shipment.

In the factory settings and after initializing the settings, the linear output is as shown below.

When shipped from the factory, voltage output is set.

Selection of current output or voltage output is accomplished by the current / voltage select switch on the bottom of the controller.

Linear output default setting		Operation after setting the standard laser reception volume	
Voltage output	±4V	Intensity of laser beam received display	Full laser beam received: +4V Full laser beam interrupted: -4V
		Intensity of laser beam interrupted display	Full laser beam received: -4V Full laser beam interrupted: +4V
Current output	4 to 20mA	Intensity of laser beam received display	Full laser beam received: 20mA Full laser beam interrupted: 4mA
		Intensity of laser beam interrupted display	Full laser beam received: 4mA Full laser beam interrupted: 20mA

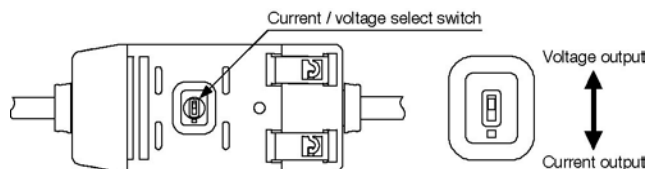

- If you desire to set the voltage output to 1 to 5V or 0 to 5V instead of 4V, set it using the monitor focus function.

■ Setting Method

Example in the case of setting a linear output of 0 to 5V.

- (1) Set the mode select switch in the 'FUN' position.

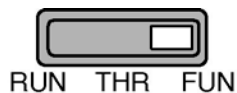

- (2) Display 'SPcL' using the LEFT / RIGHT key (◀/▶).

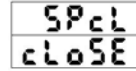

- (3) Change 'cLoSE' to 'SEt' using the UP / DOWN (▲/▼) keys, then press the ENT (■) key.

- (4) Display 'FocUS' using the LEFT / RIGHT key (◀/▶).

- (5) Set the linear output by the following procedure.

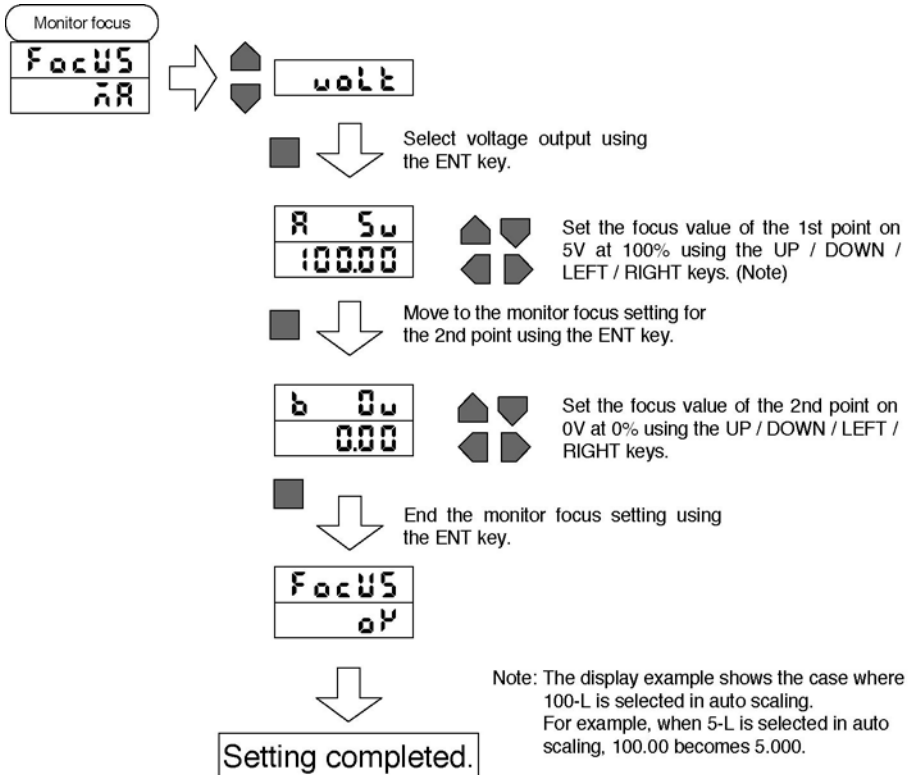

- (6) Set the mode select switch to the 'RUN' position and return to the measuring state.

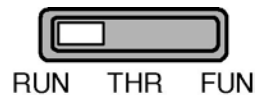

1.7 Setting The Judgment Output

Set the threshold values for the HIGH and LOW judgment output.

The main digital display shows the measurement values and the sub-digital display value shows the threshold value.

■ Setting method

- (1) Set the mode select switch in the 'THR' position.



- (2) Select the threshold value for the direct input setting method using the threshold select switch. The selected threshold value is set.



- (3) Pressing the UP / DOWN / RIGHT / LEFT key causes the set column to blink.

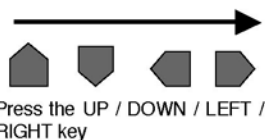
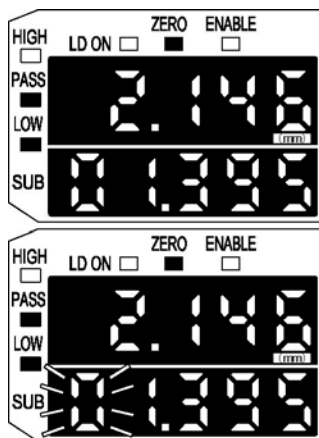

- (4) Pressing the RIGHT / LEFT key shifts the column up or down and pressing the UP / DOWN key raises or lowers the numerical value and sets it.

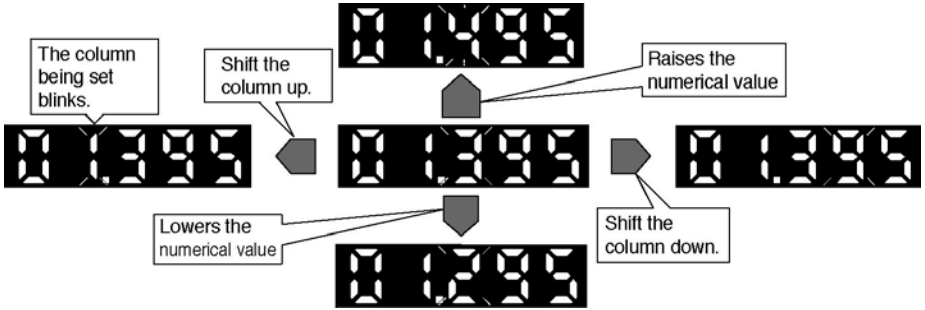

- (5) When setting of the value is complete, press the 'ENT' key (■) to enter the value.

- (6) All the digits of the sub-digital display will blink 2 times, then the numerical value will be saved in memory.

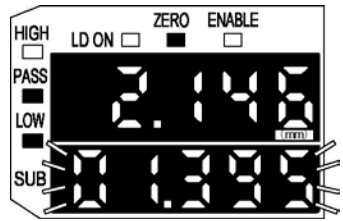

↓ After blinking 2 times, the display will remain on.

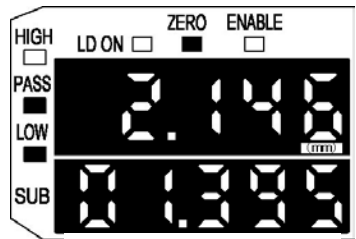

Setting completed.

- (7) Reverse the setting of the threshold value select switch between H and L, then set the other threshold value in the same way.
- (8) Set the mode select switch in the 'RUN' position and return to the measuring state.

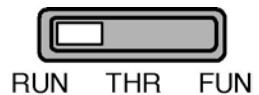

1.8 Starting Measurement

Start measurement.

The measurement value is displayed in the main-digital display.

The judgment result is shown by the HIGH / PASS / LOW judgment output indicator and is output on the judgment output line.

Current / voltage output is also output corresponding to the measurement value in the linear output.

■ Setting method

- (1) Set the mode select switch in the 'RUN' position.

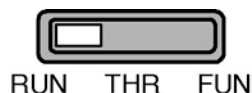

- (2) Start measurement.

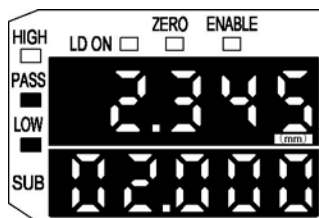

The measurement value is displayed in the main-digital display.

The display content of the sub-digital display indicates the threshold value, voltage value, current value, laser reception intensity, resolution or present value, whichever has been selected.

※ The numerical values in the illustration are display examples.

CHAPTER 2

BEFORE USE

Explains the preparations necessary before turning on the power, such as giving an outline of the product and installing, connecting and wiring it, etc., and explains the settings to be made when the power is first turned on.

2.1	Laser Collimated Sensor.....	40
2.1.1	Outline of the HL-T1 series.....	40
2.1.2	Sensor head	41
2.1.3	Controller	41
2.1.4	Calculation unit	41
2.2	Parts Description.....	42
2.2.1	Sensor head	42
2.2.2	Controller (optional)	43
2.2.3	Calculation unit (optional)	44
2.2.4	Controller CH No.	44
2.3	External Inputs and Outputs.....	45
2.3.1	Input / output lines	45
2.3.2	Inputs	46
2.3.3	Outputs	48
2.4	Input / Output Circuit Diagrams.....	50
2.4.1	NPN output type (HL-AC1)	50
2.4.2	PNP output type (HL-AC1P)	51
2.5	Mounting Method	52
2.5.1	Sensor head	52
2.5.2	Controller	54
2.6	Connections	55
2.6.1	Connection cable to controller	55
2.6.2	Connection cable to sensor head	55
2.6.3	Cable extension	56
2.6.4	Controller to calculation unit	57
2.7	Laser Beam Alignment.....	58
2.8	Setting Auto Scaling	59
2.9	Setting the Standard Laser Beam Reception Intensity	62

2.1 Laser Collimated Sensor

2.1.1 Outline of the HL-T1 series

The HL-T1 series is a high precision, sophisticated laser collimated sensor, which, by irradiating the detected object with collimated laser beam, can measure positioning or width with high precision. It is used as a combination of a sensor head and controller.

Model No.	Description
HL-T1001A	Sensor head: Sensing width ϕ 1mm (Note)
HL-T1005A	Sensor head: Sensing width 5mm
HL-T1010A	Sensor head: Sensing width 10mm
HL-T1001F	FDA compatible sensor head: Sensing width ϕ 1mm (Note)
HL-T1005F	FDA compatible sensor head: Sensing width 5mm
HL-T1010F	FDA compatible sensor head: Sensing width 10mm
HL-AC1	Controller: NPN output
HL-AC1P	Controller: PNP output
HL-AC1-CL	Calculation unit
HL-T1SV1	Side view attachment: Exclusively for the HL-T1001□ / HL-T1005□
HL-T1SV2	Side view attachment: Exclusively for the HL-T1010□
CN-HLT1-1	Sensor head to controller connection cable: 1.5m
HL-T1CCJ4	Extension cable: 4m
HL-T1CCJ8	Extension cable: 8m
MS-HLT1-1	Sensor head mounting bracket for the HL-T1001□ / HL-T1005□
MS-LA3-1	Sensor head mounting bracket for the HL-T1010□
MS-HLAC1-1	Controller mounting bracket

Note: In the case that the detection distance is 0 to 500mm. When it is 500 to 2,000mm, the size is ϕ 1 to ϕ 2.5mm.

2.1.2 Sensor head

A laser beam shines from the emitter as collimated light and changes in the beam due to the sensing object are picked up by the receiver, then the resultant values are converted to electric signals and sent to the controller.

Depending on the sensing width, there are 3 models. Also, through installation of an optional side view attachment (**HL-T1SV□**), the direction in which the laser beam shines can be changed. Use the FDA compatible model **HL-T1□□□ F** for exports to the US.

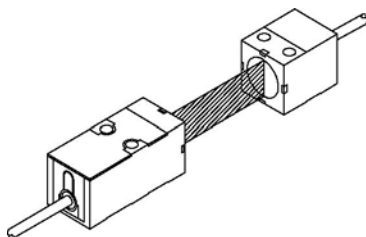

2.1.3 Controller

The controller receives signals from the sensor head, displays those values and outputs them to external devices.

It also performs hold and timing control, etc. and 2 connected units can perform calculations.

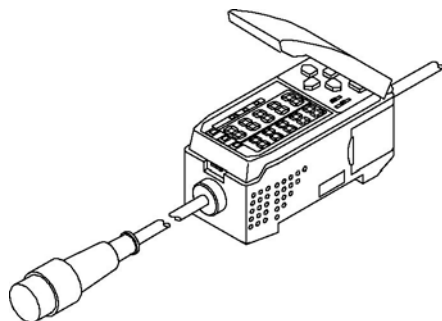

2.1.4 Calculation unit

This unit is necessary when 2 controllers are connected together.

A-B and A+B calculations can be performed by connecting 2 units together.

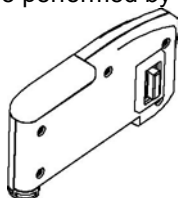

2.2 Parts Description

2.2.1 Sensor head

CHAPTER 2

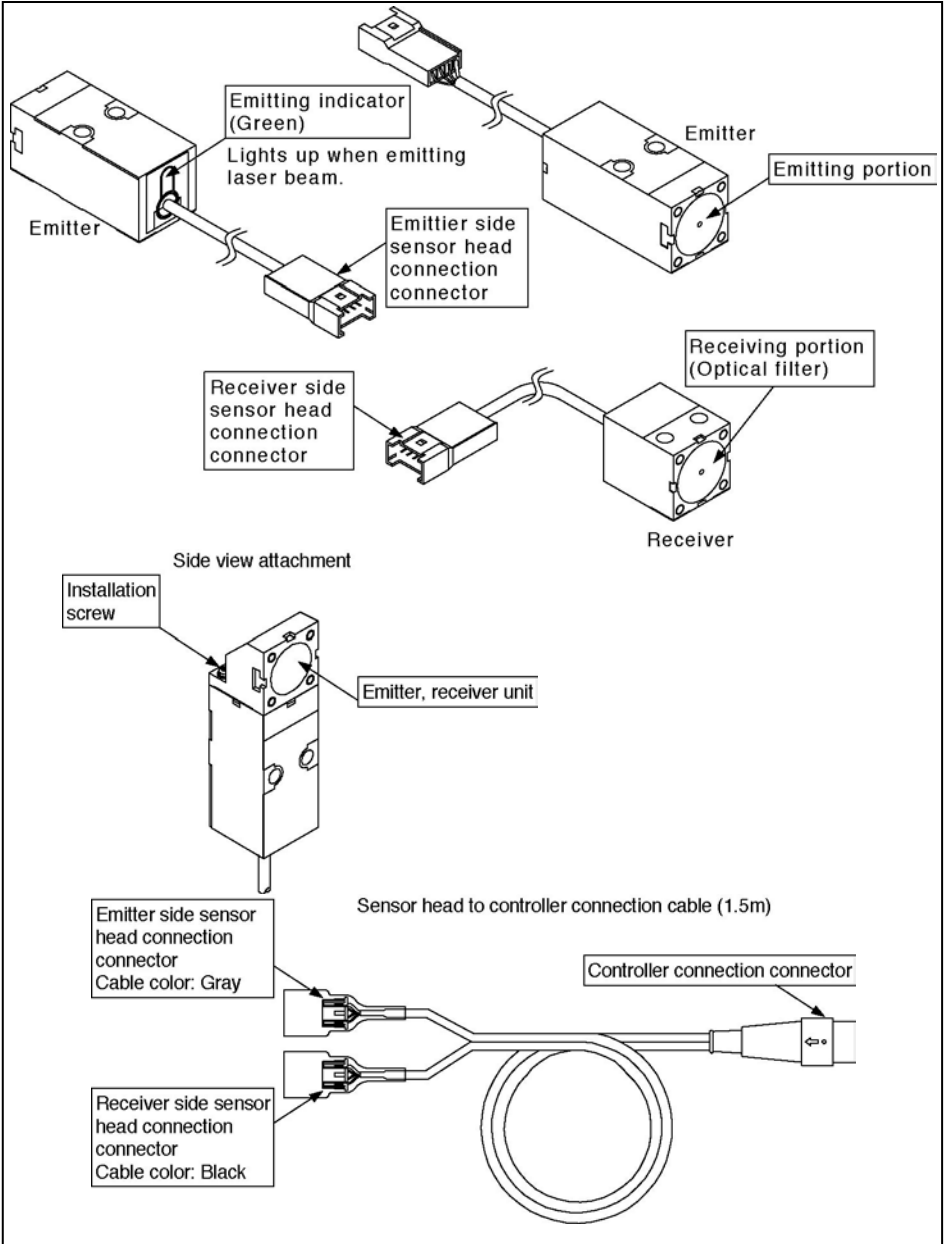

2.2.2 Controller (optional)

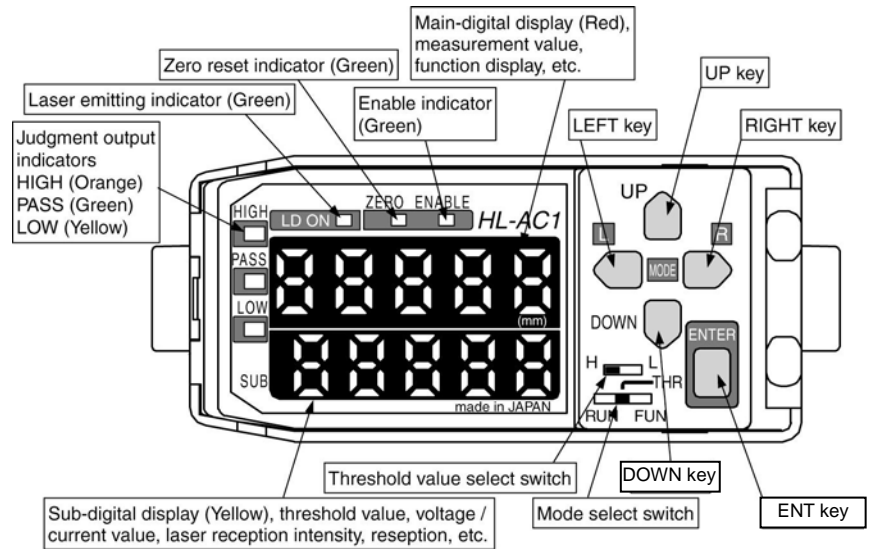
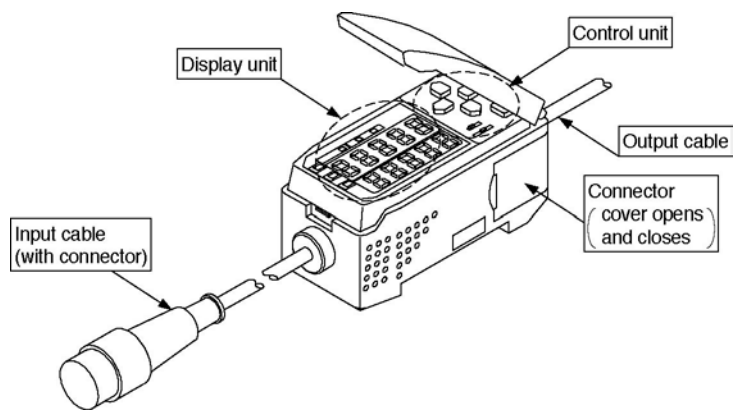

The current output / voltage output select switch is located on the bottom of the controller.

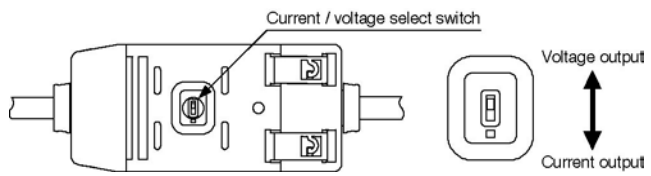

2.2.3 Calculation unit (optional)

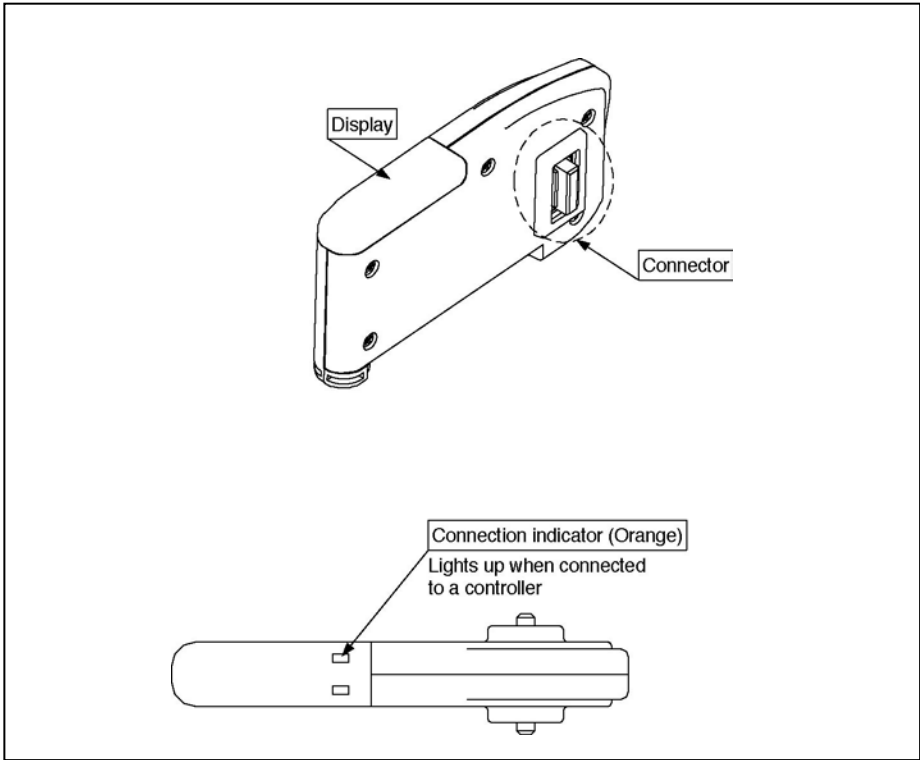

2.2.4 Controller CH No.

If 2 controllers are connected using the calculation unit, 1CH comes to the top side and 2CH comes to the bottom side when the normal display direction is used.

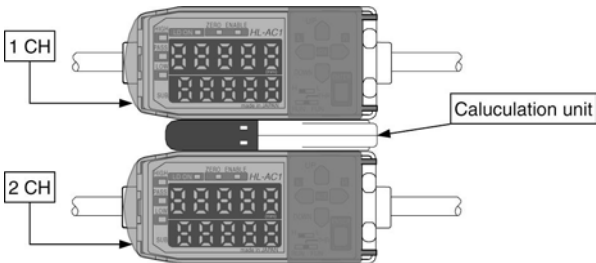

2.3 External Inputs and Outputs

2.3.1 Input / output lines

External input and output lines are assigned to the following functions.

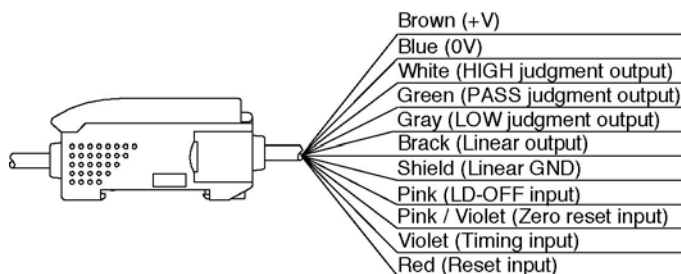

The linear output is switched by the current / voltage select switch on the bottom of the controller.

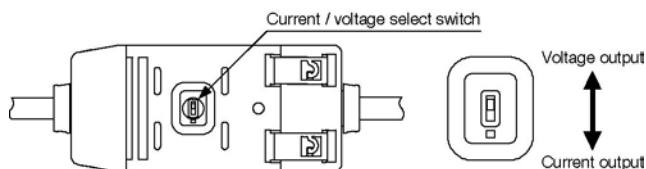

- Notes:1) When high resolution is particularly necessary, use a stabilized power supply that is separate from any other power system.
- 2) If wiring is done incorrectly, it could cause damage, so carry out wiring correctly.
 [Particularly in the case of the linear output (Black), do not bring it in contact with any other wire. In case not using the linear output, insulate cable core and shield cable each to prevent contacting of them.]
- 3) Use the 0V (Blue) for the power supply and use the linear GND (shielded cable's outside sheath) together with the linear output (Black) for the linear output. Even if the linear output is not used, use the linear GND connected to 0V.

2.3.2 Inputs

(1) +V

This is the power supply. Connect a 12 to 24V DC power supply.

(2) 0V

This is the 0V power supply.

(3) LD-OFF Input

When this input goes ON, laser lighting (emission) stops. At such a time, 'LD OFF' is displayed in the sub-digital display. At this time, the linear output, digital display, judgment output and judgment output display are output in accordance with the setting when measurements is not being performed.

(4) Zero reset input

This input specifies execution or canceling of zero reset.

The following settings are performed when this input.

When the input pulse ON time	Operation
0.2 to 0.8 sec.	Zero reset is executed.
1 sec. or more	Zero reset is canceled.

When this input goes OFF, zero reset is executed or canceled.

(5) Timing input

This is used in timing control when the hold function is enabled.

While this input is ON, sampling is performed, and it is used to hold the measurement value at the rise time when the input changes from OFF to ON.

(6) Reset input

This is an input which resets each output.

When this input goes ON, internal calculation is interrupted and fixed values are output for the judgment output and linear output.

By selecting settings when measuring is not being performed, the following type of outputs is performed.

	Setting when measuring is not being performed	
	CLAMP	KEEP
Judgment output	All OFF	Held at the value just before
Linear output	Fixed at clamp value (Note)	
Main-digital display	' - - - - - '	
Sub-digital display	' r 55Et '	' r 55Et '

(Note) The clamp value can be set. See " 3.8.17 Non-measuring time setting" for how to set the clamp value
 Voltage value: -5 V to 5 V or approx. 5.5 V
 Current value: 3 to 21mA or approx. 23mA

It is set on KEEP at the time of factory shipment.



When reset is input, the averaging calculation is cleared, so the response of the judgment output may be delayed longer than normally immediately after the reset input is cleared.

2.3.3 Outputs

(1) Judgment output

There are 3 types of judgment output, HIGH / PASS / LOW.

The timing and time chart for each respective output are shown in the table below and in the graph on the next page.

● Threshold value

This is the value that becomes the boundary for the HIGH / PASS / LOW outputs.

There are two threshold values, the 'HIGH threshold value' and the 'LOW threshold value'. The threshold value has 'Hysteresis'.

● Hysteresis (Hysteresis width)

This is said to be the difference between the operation and reset measurement values.

If the hysteresis is too small, chattering could occur, or conversely, if the hysteresis is too great, resetting may become difficult.

Timing for switching the judgment output

Measurement Value	Judgment Output
When it becomes more than the HIGH threshold value.	PASS → HIGH
When it becomes less than ('the HIGH threshold value' – 'the hysteresis width').	HIGH → PASS
When it becomes less than the LOW threshold value.	PASS → LOW
When it becomes more than ('the LOW threshold value' + 'the hysteresis width').	LOW → PASS

Relationship between the measurement value and judgment output

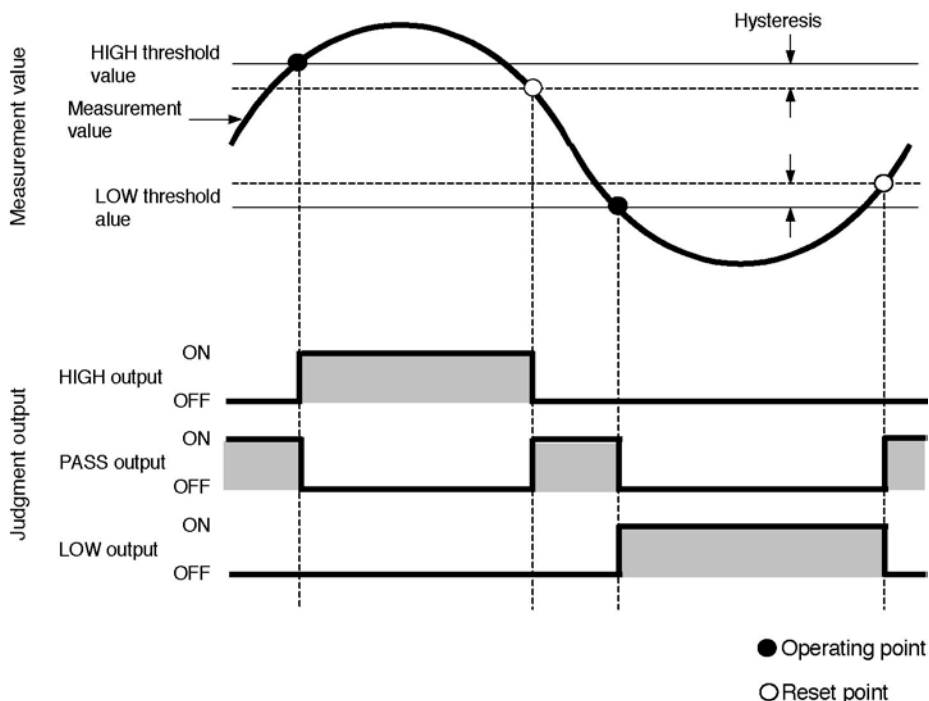

(2) Linear output

Using the current / voltage select switch, the output can be switched between current output and voltage output.

Current output Guaranteed range: 4 to 20mA (default value: 4 to 20mA)

Voltage output Guaranteed range: -5 to +5V (default value: -4 to +4V)

If the monitor focus function is used, the output scale can be changed.

The maximum value during current output is 23mA and the maximum value during voltage output is +5.5V.

(3) Linear GND

This is the GND used for linear output.

This GND should be connected separately (isolated) from the normal GND (0V).

In order to guarantee the resolution during linear output, be sure to connect this ground.

2.4 Input / Output Circuit Diagrams

2.4.1 NPN output type (HL-AC1)

CHAPTER 2

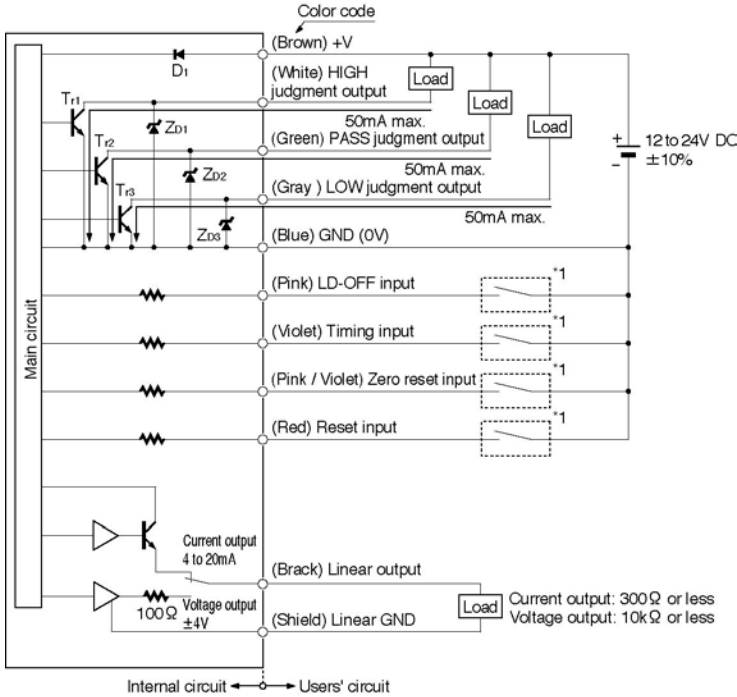

*1

Non-voltage contact or NPN open-collector transistor

Low (0 to 1.5V) : Effective
High (+V or open) : Ineffective

Signal D_1 : Reverse supply polarity protection diode.
 Z_{D1} , Z_{D2} , Z_{D3} : Surge absorption zener diode.
 T_{r1} , T_{r2} , T_{r3} : NPN output transistors

2.4.2 PNP output type (HL-AC1P)

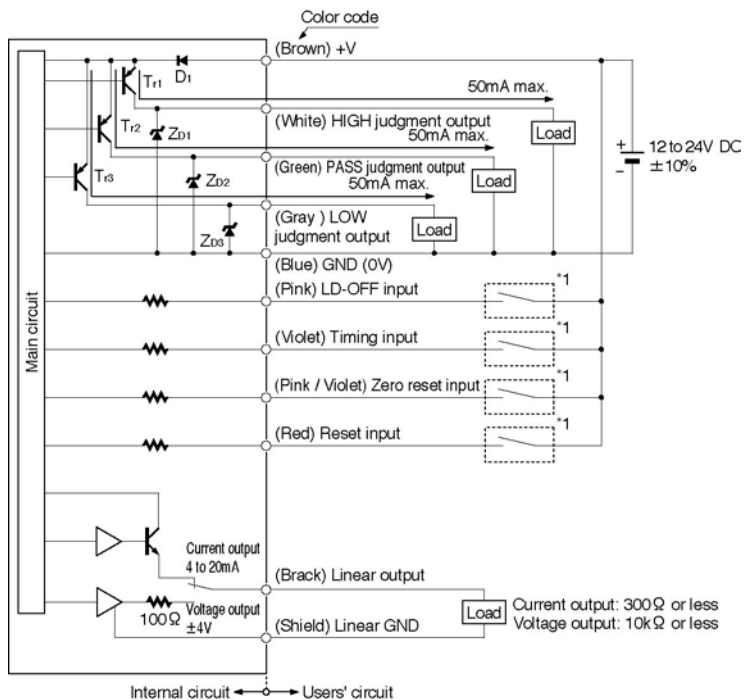

*1

Non-voltage contact or PNP open-collector transistor

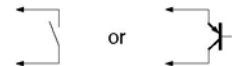

Low (0V or open) : Effective
High [+V to (+V - 1.5V)] : Ineffective

Signal D₁: Reverse supply polarity protection diode.
Z_{D1}, Z_{D2}, Z_{D3}: Surge absorption zener diode.
T_{r1}, T_{r2}, T_{r3}: PNP output transistors

2.5 Mounting Method

2.5.1 Sensor head

[Mounting the sensor head]

Mount the emitter and receiver.

- The laser beam has directivity, so be careful of the mounting direction of the emitter and receiver.

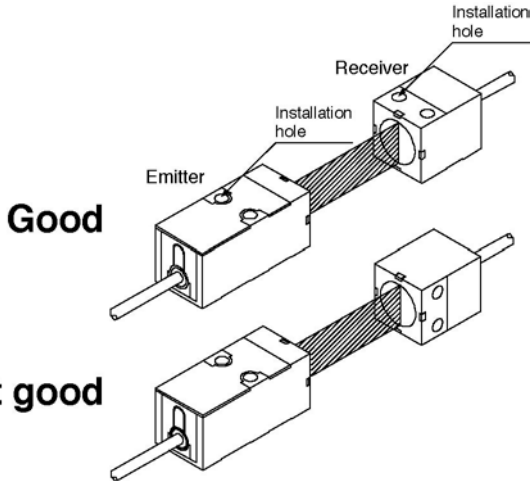

- The tightening torque should be $0.3\text{N}\cdot\text{m}$ or less.
- Use the screws with washers supplied with the sensor for mounting.

HL-T1001□ / HL-T1005□

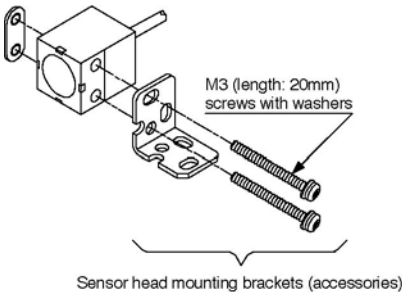

HL-T1010□

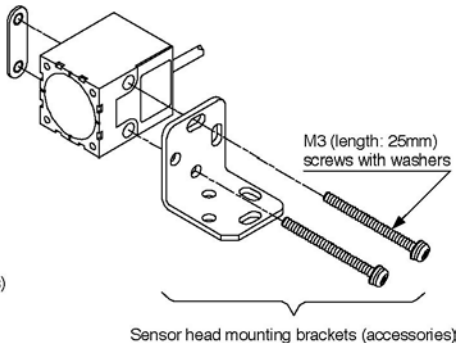

Please

Do not touch the emitter and receiver surfaces of the sensor head. If fingerprints, etc. get on them, it will become impossible to measure correctly. If you touch them by accident, stop the laser emission, then use a soft lint-free cloth or lens cleaning paper to wipe off the surface.

[Mounting the side view attachment (HL-T1SV□)]

- The optional side view attachment (HL-T1SV□) can be mounted on one side only, on either the emitter or the receiver, and used.
- Use the M2 (length: 6mm) screws supplied with the side view attachment to mount it, and the tightening torque should be 0.08N·m or less.

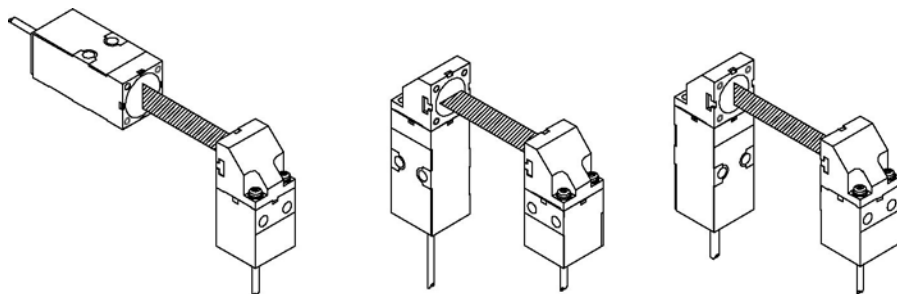

Please

- Use equal tightening torques on both the left and right sides during mounting. If the torque on one side is stronger than the other side, it could cause the laser beam to be distorted.
- If the screws are tightened beyond the specified tightening torque, there is danger that the part where the mounting holes are located could be damaged. Please follow the standard torque specifications. Also be sure to use the M2 screws with washers (length: 6mm) supplied for mounting screws.
- When using the side view attachment, be sure to adjust the laser beam axis after installing the attachment. Also be sure to perform the standard light reception intensity setting after adjusting the sensor head laser beam axis.

2.5.2 Controller

[Mounting]

- (1) Fit the front of the hook on the 35mm width DIN rail.
- (2) Push the rear portion of the hook down onto the 35mm width DIN rail.

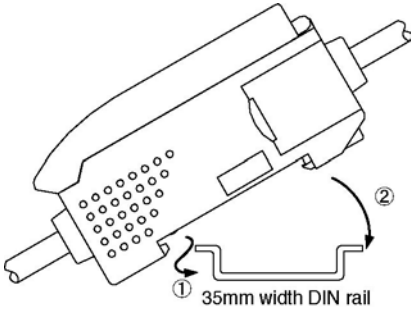

[Dismantling]

- (3) Take hold of the controller and push it in the direction of its front end.
- (4) Lift up the front end. The controller can then be removed.

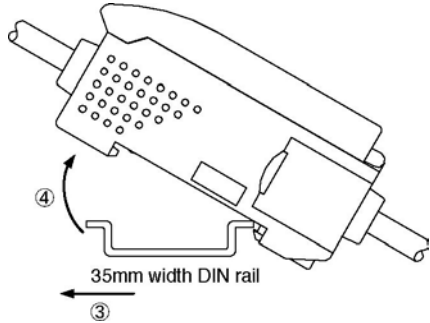

- Do not attempt to reverse the order of steps (1) and (2). If mounting is attempted in reverse order, it could result in reducing the mounting strength of the mounting fitting.
- If the front end of the controller is lifted up without first pushing it in the direction of the front end, the hook on the rear end could be broken, so exercise caution.

Please

2.6 Connections

2.6.1 Connection cable to controller

(1) Insert the controller connection connector on the connection cable with the controller's input cable connector, inserting it until the ring on the outside of the connector locks.

(2) To disconnect the cable take hold of the ring on the outside of the connection cable's connector and the controller's connector, and pull them straight apart.

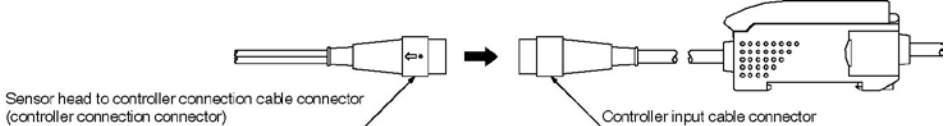

Please

- If the ring on the outside of the connection cable's connector only is pulled, there is danger of the wires in the controller's input cable being disconnected, so exercise caution.
- Do not touch the terminals inside the connectors.

2.6.2 Connection cable to sensor head

(1) Insert the connection cable's sensor head connection connectors in the emitter / receiver connectors until their claws lock in the grooves of the emitter / receiver connectors. Connect the emitter side to the connector with a gray cable and connect the receiver side to the connector with a black cable.

(2) To disconnect the connectors, disengage the claws on the connection cable's sensor head connection connectors from the grooves in the emitter and receiver connectors and pull them straight apart.

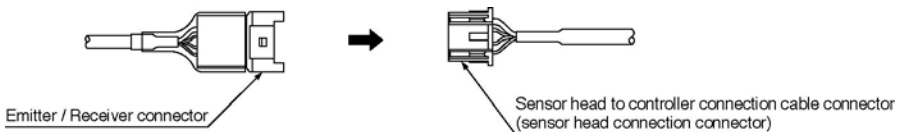

(3) The antistatic cover has been fitted on the connection cable.

After connecting the sensor head and connection cable, be sure to cover the connector with the anti-static cover.

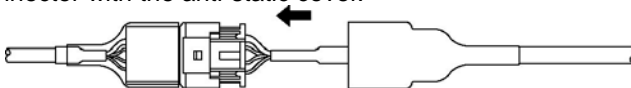

Please

- Do not touch the terminals inside the connectors.
- Be careful not to cause static electricity to be discharged on the connectors.

2.6.3 Cable extension

Use the exclusive cables (optional), to extend the cables between the sensor head and the controller.

A 4m type (**HL-T1CCJ4**) and an 8m type (**HL-T1CCJ8**) are available. Use the extension cable by connecting it between the connection cable and the controller.

Please

Avoid connecting two or more extension cables together and using them.

2.6.4 Controller to calculation unit

If the calculation unit is used, connect the calculation unit and the controller together.

- (1) Mount the controller on the 35mm width DIN rail. (See 2.5.2, 'Controller' concerning the mounting method.)
- (2) Open the cover on the connector of the controller. Lift up on the connector cover and slide it to open it.

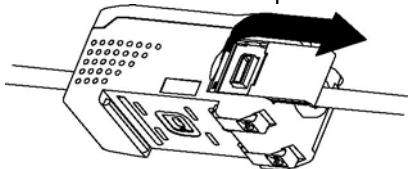

- (3) Fit the front end of the calculation unit (**HL-AC1-CL**) mounting fitting on the 35mm width DIN rail.
- (4) Push the rear end of the calculation unit's mounting fitting down onto the 35mm width DIN rail.
- (5) Slide the calculation unit along the DIN rail and insert the connection connector of the calculation unit in the connection connector on the controller until a clicking sound can be heard.
- (6) Slide the other controller along the DIN rail until the calculation's connector inserts into the controller's connector and there is a clicking sound.

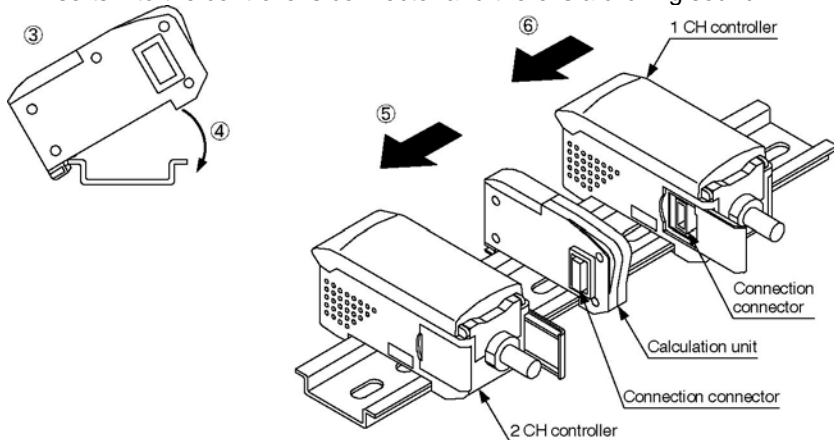

Please

Be sure to mount the parts on the DIN rail before connecting them together.

Please

If the controllers move due to vibration, etc., mount end plates (**ME-DIN-E**) on both sides. Contact our sales office concerning the end plates (**ME-DIN-E**).

2.7 Laser Beam Alignment

When the emitter and receiver have been installed, be sure to align the laser beam. Affix the laser beam alignment sticker supplied to the front of the receiver and adjust the emitter and receiver so that the emitted beam strikes the center of the cross marks. After alignment, be sure to remove the sticker.

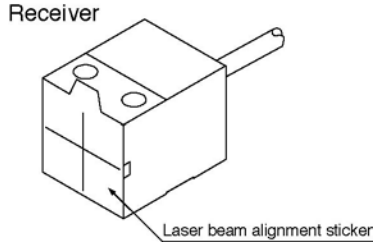

If you desire to make further adjustments to maximize the laser beam setting, adjust it to the position where the controller's display reaches the maximum.



If the **HL-T1001** □ is installed with a 2 m distance, at first the laser beam may not strike the laser beam adjustment sticker, and it may be difficult to confirm the position of the laser beam.

At such a time, place a large sheet of paper, etc. on the back of the receiver to enable confirmation of the beam. This will make the laser beam alignment easier.

Please

If the regular reflection light from the workpiece is strong, such as in the case of a glass or mirror-surface item, the reflection light may disallow proper detection. In such a case, adjust the mounting angle so that the reflection light does not enter the emitter or receiver.

2.8 Setting Auto Scaling

This determines whether readings will be displayed in the main digital display in mm units or in % units, and whether the intensity of laser beam received by the receiver, or the intensity of laser beam interrupted, will be displayed.

The default state set at the factory is display of % units and display of the intensity of laser beam received by the receiver.

(1) Selecting the display

Select whether the laser beam reception intensity will be displayed in the main digital display in % units or in mm units of the 5mm / 10mm / 30mm width, as shown in the table of the next page.

(2) Selecting the amount of laser beam received / amount of laser beam interrupted

Select whether the display and the linear output will operate with respect to the intensity of laser beam received by the receiver or the intensity of laser beam interrupted.

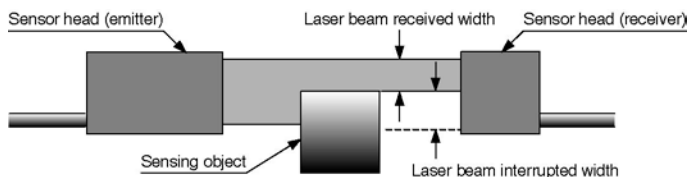

If you desire to measure the width of laser beam received → Select - L.

If you desire to measure the width of laser beam interrupted → Select - d.

(3) Setting

Select the combination of display and intensity of laser beam received / intensity of laser beam interrupted, then press the ENT key to fix the setting.

Example) In the case of the **HL-T1005A** with a measuring width of 5mm, displaying the intensity of laser beam received by the receiver.

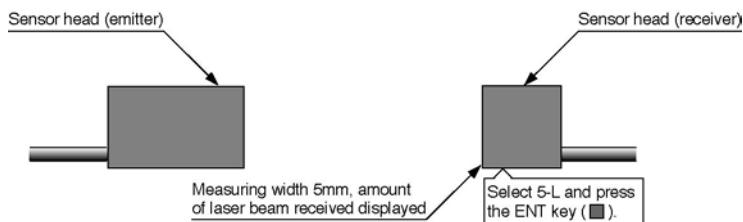

■ Setting examples according to each sensor head

Sensor Head	Detection width	Intensity of laser beam received / Amount of laser beam interrupted display	Auto scaling setting	Operation		
				Output operation	Display	Linear output
HL-T1005A HL-T1005F	5mm	Intensity of laser beam received display	5-L	When full laser beam is received	5mm	+4V
				When full laser beam is interrupted	0mm	-4V
		Intensity of laser beam interrupted display	5-d	When full laser beam is received	0mm	-4V
				When full laser beam is interrupted	5mm	+4V
HL-T1010A HL-T1010F	10mm	Intensity of laser beam received display	10-L	When full laser beam is received	10mm	+4V
				When full laser beam is interrupted	0mm	-4V
		Intensity of laser beam interrupted display	10-d	When full laser beam is received	0mm	-4V
				When full laser beam is interrupted	10mm	+4V
HL-T1001A HL-T1001F	Ø1mm	Intensity of laser beam received display	100-L	When full laser beam is received	100%	+4V
				When full laser beam is interrupted	0%	-4V
		Intensity of laser beam interrupted display	100-d	When full laser beam is received	0%	-4V
				When full laser beam is interrupted	100%	+4V

Note: The linear output shows an example of the default value in the case of voltage output.

Please

If auto scaling is set, all the settings are automatically returned to the default values set at the time of factory shipment, so exercise caution.

■ Setting method

(1) Set the Mode Select switch in 'FUN' position.

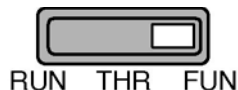

- (2) Display 'Auto 5' using the LEFT / RIGHT keys (◀/▶).

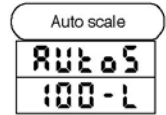

- (3) Select the display contents using the UP / DOWN keys (▲/▼).

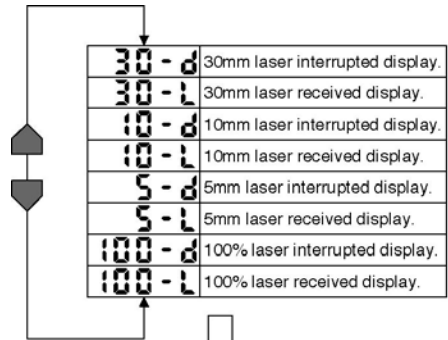

- (4) Fix the selection using the ENT key (■).

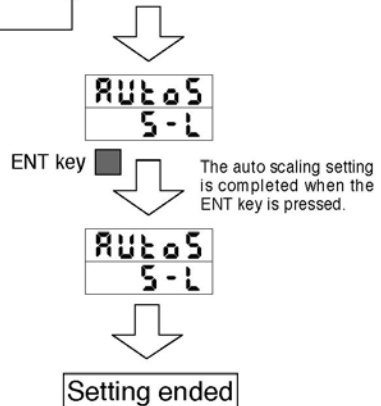

※ The numerical values in the illustration are setting examples.

Please

If auto scaling is set, all the settings are automatically returned to the default values set at the time of factory shipment, so exercise caution. Perform the settings for the auto scaling function first of all.

2.9 Setting the Standard Laser Beam Reception Intensity

When first installing the sensor head and aligning the laser beam, set the standard laser beam reception intensity.

Also perform the standard laser beam reception intensity setting if the installation position of the sensor head has been changed.

■ Setting method

(1) Set the Mode Select switch in the "RUN" position.

(2) Set the full laser beam receiving state.

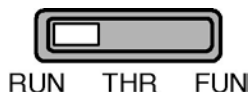

(3) Press the DOWN key (▼) for 3 seconds or more.

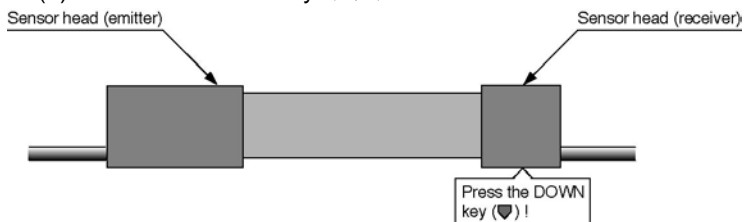

(4) If the setting was done correctly, it will be near the value set by the auto scaling setting.

Example; If 100-L was set, it will be near 100.00.

If 100-d was set, it will be near 0.00.

If the value is not near the set value, it is not set correctly.

Align the light beam again.

Please

Perform this setting after the auto scaling setting is completed.

If auto scaling is set after the standard laser beam reception intensity is set, the standard laser beam reception intensity setting will be canceled.

Please

Be sure to perform the standard laser beam reception intensity setting after the power has been switched on for 10 minutes or more and the display values have stabilized.



At a time when you are not setting the standard laser beam reception intensity, the value in the main-digital display will not be a value near the full scale (F.S.) value, even if the laser beam is striking the receiver normally.

It will be a value that is smaller than the full scale (F.S.) value.

CHAPTER 3

EXPLANATION OF FUNCTIONS

Provides an outline of the functions and their operation, and gives an explanation concerning the functions that can be set and setting methods.

3.1	Outline of Display Operations	66
3.1.1	Operating face	66
3.1.2	Outline of indicators	67
3.1.3	Outline of operating switches	68
3.2	Outline of Functions	69
3.2.1	RUN mode	69
3.2.2	THR mode	69
3.2.3	FUN mode	69
■	Status transition chart in the FUN mode	70
■	Here the procedure for scaling settings is shown.	71
■	Here the procedure for setting related SEt settings is shown.	72
■	Here the procedure for performing display related dISP settings is shown.	73
■	Here the procedure for other ELc settings is shown.	73
■	Here the procedure for the auto scaling setting is shown.	73
3.3	List of Default Setting Values	74
3.4	Display at Startup	75
3.5	RUN Mode	76
3.5.1	Basic operation	76
3.5.2	Changing the sub-digital display	76
■	Threshold value display	77
■	Voltage value display	77
■	Current value display	77
■	Laser beam reception intensity display	78
■	Resolution display	78
■	Current value display	78
3.5.3	Zero reset / cancellation	79
3.5.4	Setting the standard laser beam reception intensity	83
3.5.5	Other functions in the RUN mode	84
■	Timing input	84
3.6	THR (Threshold) Mode	85
3.6.1	Direct threshold value input	86
■	Changing the numerical value	86
■	Fixing the numerical value	87
3.6.2	Teaching	88
3.6.3	Teaching positioning	88
■	Example of teaching positioning	88
3.6.4	2-point teaching	90
■	Example of 2-point teaching	90
3.6.5	Automatic teaching	93
■	Example of automatic teaching	93

3.7	FUN (Function) Mode	96
3.7.1	Basic operation	96
3.7.2	Basics of mode changes	96
3.7.3	Changing setting values (other than numerical values)	97
3.7.4	Changing setting values (in case of numerical values)	99
■	Setting the numerical value (when normal)	100
■	Setting the numerical value (when abnormal)	101
3.8	Functions That Can Be Set In The FUN Mode	102
3.8.1	Auto scaling function	102
3.8.2	Scaling function	104
■	If you desire to offset the display value (1-point scaling A)	107
■	If you desire to correct the display value to the actual width (2-point scaling A)	108
■	If you desire to use the desired display value (2-point scaling B)	110
3.8.3	Average sampling rate	111
3.8.4	Hysteresis width setting	112
■	Direct input	112
■	Auto hysteresis setting	112
3.8.5	Hold	113
■	Normal (no hold): OFF	114
■	Peak hold: P-h	115
■	Bottom hold: b-h	116
■	Sample hold: S-h	117
■	Peak to peak hold: PP-h	118
■	Average hold: AVE-h	119
●	Self trigger level	120
■	Peak hold + Self-up trigger	123
■	Peak hold + Self-down trigger	124
■	Judgment outputs while the hold mode is in use	125
■	Setting Delay Time	126
3.8.6	Timer	129
■	Timer period	129
■	Without timer	129
■	OFF delay timer	129
■	ON delay timer	129
■	ONE SHOT timer	129
3.8.7	Adjacent sensor calculation	132
■	A - B	132
■	A + B	132
■	THICK	132
■	Calculation results output	133
3.8.8	Adjacent calculation THICK (Thickness measurement)	134
3.8.9	Setting initialization	138
3.8.10	Monitor focus function	140
3.8.11	Linear output correction	144
3.8.12	Differential function	148
3.8.13	Previous value comparison	150
3.8.14	Display reverse function	153
3.8.15	ECO display function	154
3.8.16	Display digits limitation	155
3.8.17	Non-measuring time setting	156

3.8.18	Zero reset memory function.....	158
3.8.19	Gain switching	159
3.8.20	Key lock function.....	160

3.1 Outline of Display Operations

3.1.1 Operating face

The indicators and operating switches are arranged on the controller's operating face as shown in the figure below.

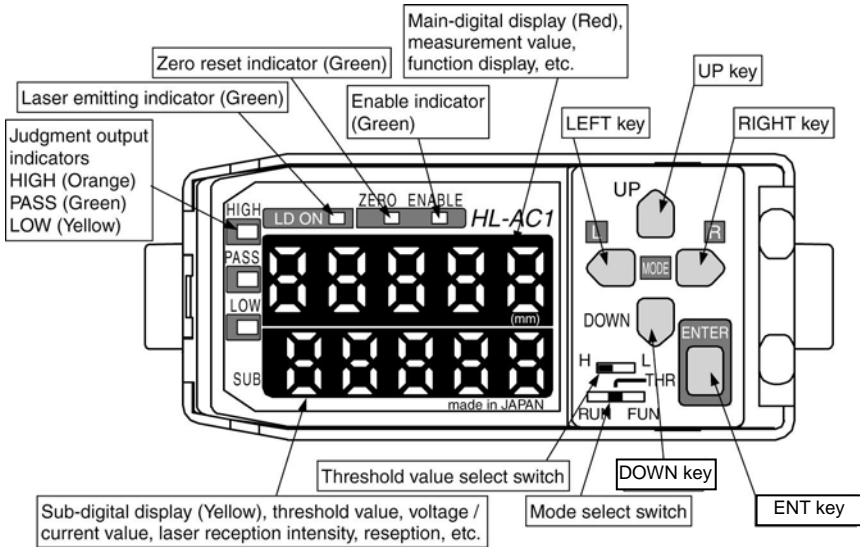

The current output / voltage output select switch is located on the bottom of the controller.

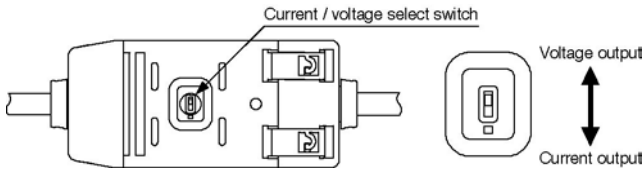

3.1.2 Outline of indicators

(1) Laser emitting indicator [LD ON (Green)]

Lights up when the sensor head is emitting laser beam (Laser Diode: LD)

(2) Judgment output indicators

[HIGH (Orange) / PASS (Green) / LOW (Yellow)]

These indicators light up under the following conditions. Each respective judgment output operates in the same way.

HIGH judgment indicator Measurement value > HIGH threshold value

PASS judgment indicator LOW threshold value ≤ Measurement value ≤ HIGH threshold value

LOW judgment indicator Measurement value < Low threshold value

(3) Main digital display [5-digit red LED display]

When in the RUN mode, it displays the measurement value (mm/%).

During measurement hold, it displays the hold value (mm/%).

In Reverse mode, the top and bottom are displayed in reverse.

(4) Sub-digital display [5-digit yellow LED display]

When in the RUN mode, it displays the threshold value, voltage/current value, light reception intensity, resolution, or current value.

When in the THR mode, it displays the respective threshold values.

In Reverse mode, the top and bottom are displayed in reverse.

(5) Enable indicator [ENABLE (Green)]

Lights up or goes off in accordance with the following conditions.

Lights up When operation is normal.

Goes off When operation is abnormal (if the sensor head is not connected when the power is turned on).

(6) Zero reset indicator [ZERO (Green)]

Lights up when the zero reset function is enabled.

3.1.3 Outline of operating switches

(1) Mode select switch [RUN / THR / FUN]

The following 3 modes can be selected.

RUN mode Measuring mode.

THR mode Threshold mode. The threshold values are set in this mode.

FUN mode Function mode. Each of the settings are set in this mode.



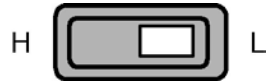

(2) Threshold select switch













When in the THR / RUN mode, this switches the threshold value (HIGH / LOW).



(3) Pushbutton switches

Generally, these switches have the following functions.

Pushbutton switch	RUN mode	THR mode	FUN mode
UP Key 	Timing input	Changes the threshold value (forward direction)	Changes the function setting value (forward direction)
DOWN Key 	Press for 3 seconds or more : Standard light reception intensity setting input	Changes the threshold value (reverse direction)	Changes the function setting value (reverse direction)
RIGHT Key 	Changes the contents of the sub-digital display (forward direction)	Changes the threshold value digit (forward direction)	Set function selection (forward direction)
LEFT Key 	Changes the contents of the sub-digital display (reverse direction)	Changes the threshold value digit (reverse direction)	Set function selection (reverse direction)
ENT Key 	Press for 1 second or more : Executes zero reset.	When threshold value is blinking : Sets the threshold value.	When the set value is blinking : Sets the value.
	Press together with the RIGHT key for 3 seconds or more : Cancels zero reset.	When the threshold value is lighted up : Executes teaching.	When the setting is being initialized : Press long to initialize.

RUN	THR	FUN
<p>Display select</p> <p>L   R</p> <p>UP  Timing input</p> <p>DOWN  Standard light reception volume setting input</p> <p> Zero reset</p> <p>ENT</p>	<p>Threshold value manual setting</p> <p>L   Digit R selection</p> <p>UP  Changes the numerical value</p> <p>DOWN  Deciding the threshold value, teaching</p> <p>ENT</p>	<p>Function select</p> <p>L   R</p> <p>UP  Change function setting</p> <p>DOWN  Set the function, numerical value</p> <p>ENT</p>

3.2 Outline of Functions

3.2.1 RUN mode

This is the mode in which ordinary measuring processing is done. The following tasks are available in this mode.

- Changes the sub-digital display
- Sets the standard light reception intensity.
- Sets zero reset / cancel
- Timing input

Set the mode select switch in RUN position.

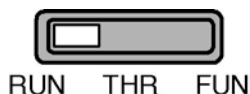

■ Status transition chart in the RUN mode

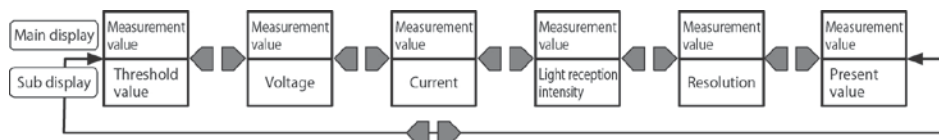

3.2.2 THR mode

This is the mode in which threshold values are set. The following tasks are available in this mode.

- Direct input of threshold values.
- Teaching of positioning points
- 2-point teaching
- Automatic teaching

Set the mode select switch in THR position.

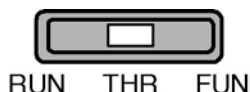

This is the threshold select switch, used to select threshold values for teaching purposes.



The threshold select switch is invalid for automatic teaching.

3.2.3 FUN mode

This is the mode in which each function is set.

Press either the RIGHT key (forward direction) or LEFT key (reverse direction) to change the mode.

Set the mode select switch in FUN position.

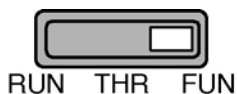

■ Status transition chart in the FUN mode

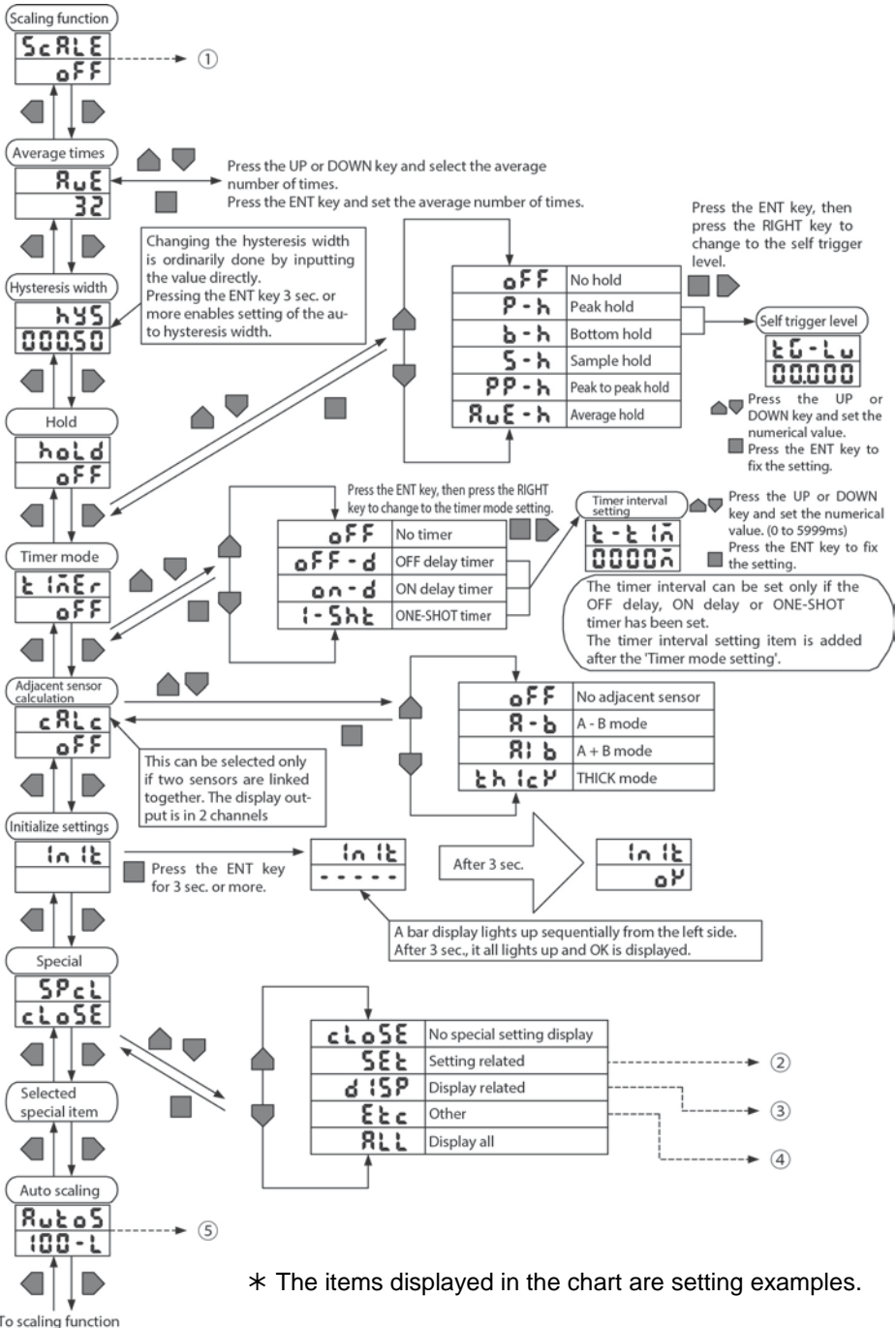

* The items displayed in the chart are setting examples.

■ Here the procedure for scaling settings is shown.

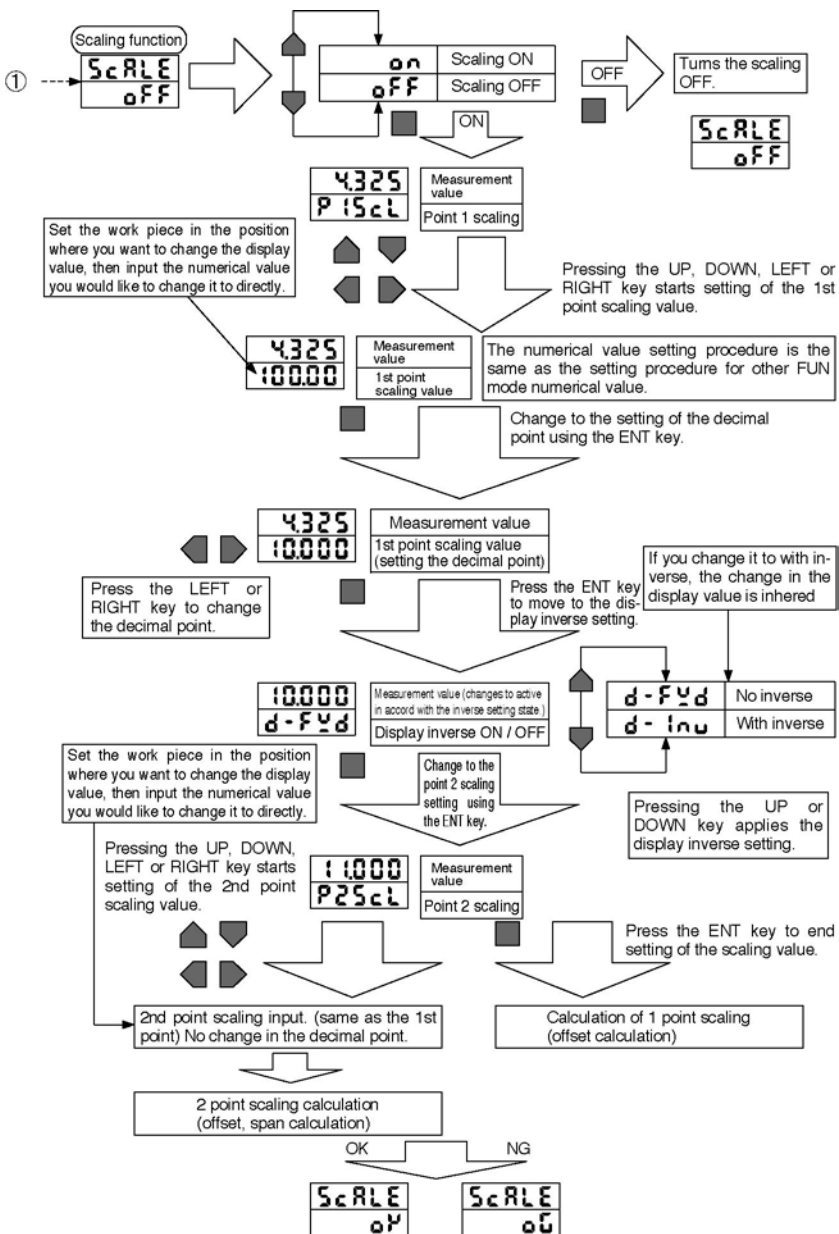

* The items displayed in the chart are setting examples.

■ Here the procedure for setting related SEt settings is shown.

Here the procedure for setting monitor focus is shown.

If 'SEt' is selected, or if 'ALL' is selected, it becomes possible to set this item.

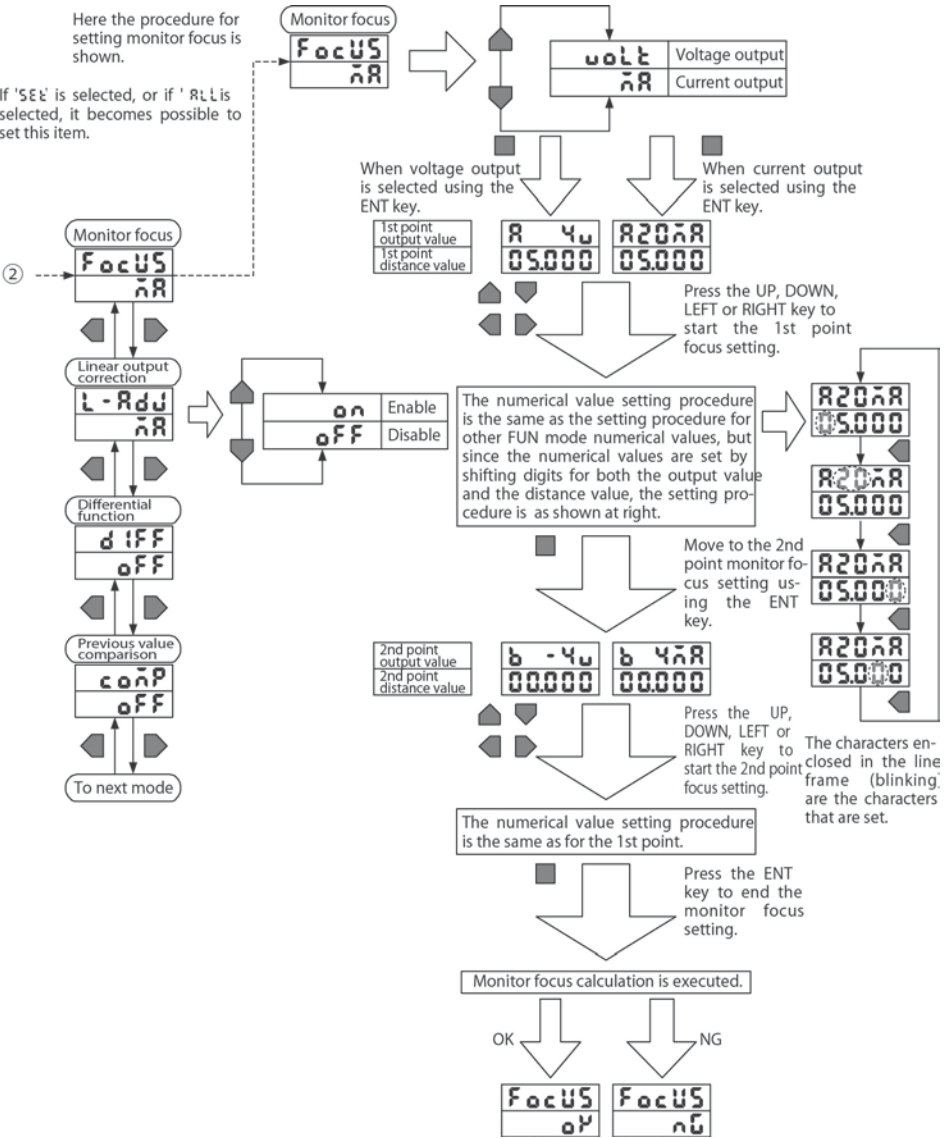

* The items displayed in the chart are setting examples.

■ Here the procedure for performing display related dISP settings is shown.

If 'dISP' is selected, or if 'RL' is selected, it is possible to set this item.

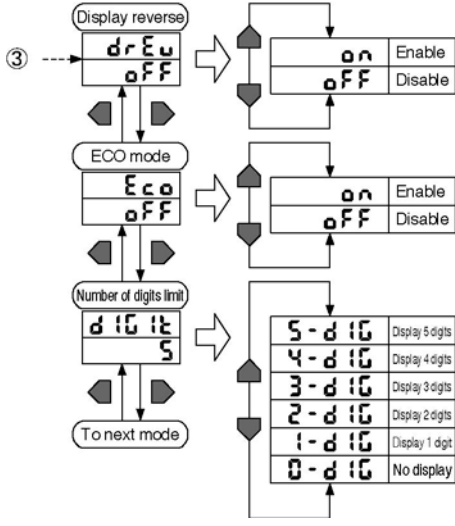

■ Here the procedure for other Etc settings is shown.

If 'Etc' is selected, or if 'RL' is selected, it is possible to set this item.

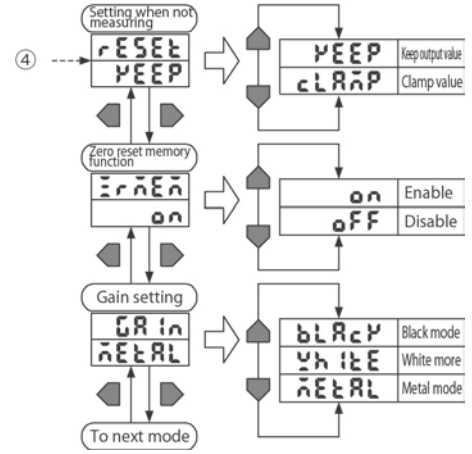

* The items displayed in the chart are setting examples.

* The items displayed in the chart are setting examples.

■ Here the procedure for the auto scaling setting is shown.

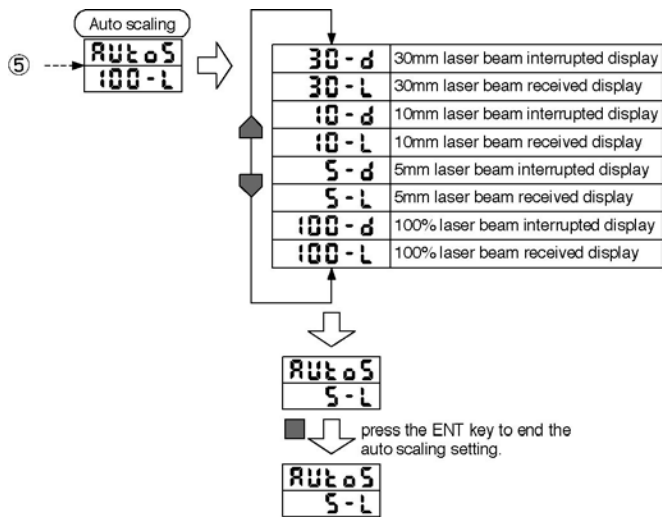

* The items displayed in the chart are setting examples.

3.3 List of Default Setting Values

This is a list of default settings which are set at the time of factory shipment.

Function	Default value
Scaling	OFF
Average times	32 times
Hysteresis width setting	0.5% of full scale (F.S.)
Hold	OFF (disabled)
Timer	OFF (disabled)
Adjacent sensor calculation (only when 2 units are connected)	OFF (disabled)
Special select	CLOSE
Monitor focus function	4V (20mA): Maximum value -4V (4mA): Minimum value
Linear output correction	OFF (disabled)
Differential function	OFF (disabled)
Display reverse function	OFF (disabled)
ECO display function	OFF (disabled)
Display digit limit	All digits displayed
Settings when not measuring	KEEP
Zero reset memory	OFF
Gain select	METAL
Auto scale value	100-L
HIGH threshold value	Display maximum value
LOW threshold value	Display minimum value
Sub-digital display function	Threshold value
Standard laser beam reception intensity setting	OFF (not set)
Zero reset function	OFF (disabled)

3.4 Display at Startup

If the power is turned on and the initialization processing finished, the display is as shown below.

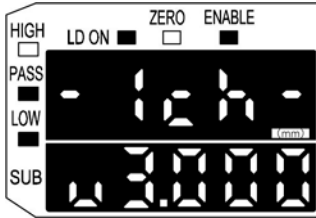

In some cases the version will be different.

The controller's format is displayed in the top row, then the number of channels is displayed.

The software version is displayed in the bottom row. The controller switches to normal operation after displaying this information for 3 seconds.

3.5 RUN Mode

This is the mode in which ordinary measuring processing is done.

The following tasks can be done in this mode.

- Changes the sub-digital display
- Sets Zero Reset / Cancel
- Sets the standard laser beam reception intensity
- Timing Input

Set the mode select switch in the RUN position.



3.5.1 Basic operation

Ordinary measurement processing is executed.

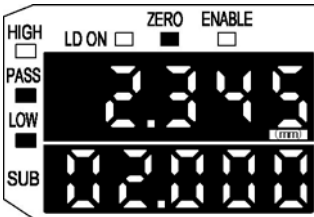

* The items displayed in the figure are setting examples.

Set the mode select switch in the RUN position.



The measurement value is displayed in the main digital display.

For the contents displayed in the sub-digital display, select threshold value, voltage value, current value, laser beam reception intensity or resolution.

3.5.2 Changing the sub-digital display

The contents displayed in the sub-digital display can be selected from threshold value (HIGH / LOW), voltage value, current value, laser beam reception intensity or resolution.

- Threshold value display..... Shows the threshold value selected using the threshold value select switch.
- Voltage value display Shows the linear output voltage level.
- Current value display Shows the linear output current level.
- Laser beam reception intensity display .. Shows the laser beam intensity level (0 to 100 or less)
- Resolution display Shows the resolution of the linear output.
- Current value display Shows the current measurement result.



These values are only criteria. There is a slight error in the actual outputs, so exercise caution.

The laser beam reception intensity shown here differs from the measurement value in the main digital display.

■ Operation method

Change the sub-digital display using the RIGHT / LEFT keys.

■ Threshold value display

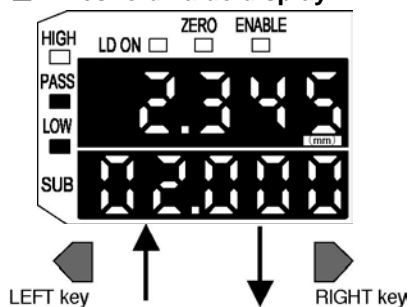

The measurement value is displayed in the main digital display.

The threshold value is displayed in the sub-digital display.

The display includes the decimal point.

The HIGH threshold value or the LOW threshold value can be selected using the H / L switch.



■ Voltage value display

The linear output's voltage level is shown.

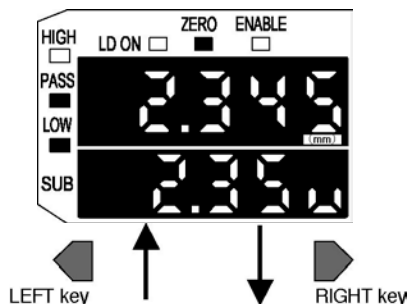

The measurement value is displayed in the main digital display.

The voltage value is displayed in the sub-digital display. A 'V' is displayed in the bottom place digit.

■ Current value display

The linear output's current level is shown.

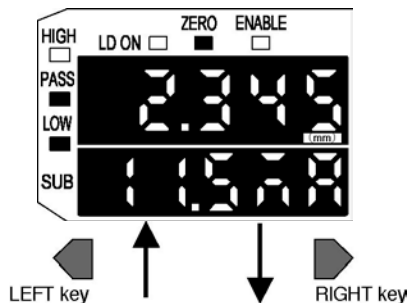

The measurement value is displayed in the main digital display.

The current value is displayed in the sub-digital display. A 'mA' is displayed in the bottom place 2 digits.

* Numerical values in the figures are display examples.

■ Laser beam reception intensity display

The laser beam reception level is displayed.

The laser beam reception level displayed here differs from the laser beam reception intensity (laser beam interrupted intensity) displayed in the main digital display. The value displayed here is the value that is not influenced by the standard laser beam reception intensity setting or undergone scaling to the full scale (F.S.) by the auto scaling function.

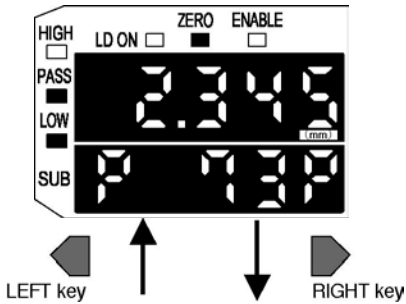

The measurement value is displayed in the main digital display.

The laser beam reception intensity is displayed in the sub-digital display. Display range (0 to 100 or less).

A 'P' is displayed in the top place and bottom place digits. A decimal point is not displayed.

■ Resolution display

The linear output's resolution is shown.

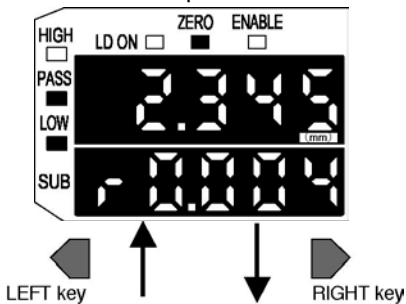

The measurement value is displayed in the main digital display.

The resolution is displayed in the sub-digital display.

A 'r' is displayed in the top place digit.

The display is updated in intervals of approximately 1 second.

■ Current value display

The current measurement result is shown.

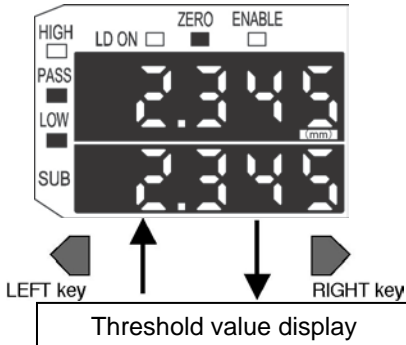

The measurement value is displayed in the main digital display.

The current value is displayed in the sub-digital display.

The value after the scaling processing and the averaging processing is displayed. However, calculation, hold, and zero reset settings are not reflected in this value.

The display is updated in intervals of approximately 1 second.

* Numerical values in the figures are display examples.

3.5.3 Zero reset / cancellation

The following tasks can be done by executing zero reset.

- The display value can be set at '0'.
- The linear output when the display reads '0' is made the center output value of the 2 points set by monitor focus. (In the default state, the current output is 12mA and the voltage output is 0V.)

Zero reset can be canceled.

The measurement value after zero has been displayed uses that value as the reference, and the measurement can show the (deviation of the work piece from that reference. Also, the judgment output judges with the display value as the reference. This is effective for tolerance judgments of work pieces.



Even if zero reset is executed, the deviation from the linear output value with respect to the measurement value does not change.

The range where zero reset can be used is between 0 and 100% when the laser beam reception intensity is displayed in % units. In the case of 5mm display or 10mm display, the zero reset range is 0 to 5mm and 0 to 10mm, respectively. A range other than this will result in an error, so exercise caution.

■ Setting method

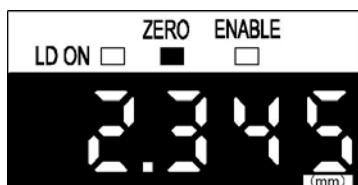

↓

 Press the ENT key.

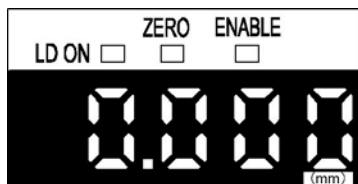

* Numerical values in the figures are display examples.

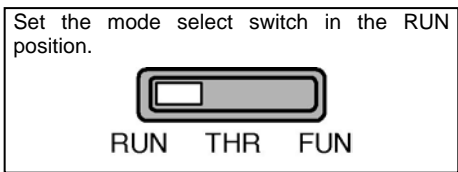

Press the ENT key for approximately 1 second or more when zero reset is not being executed.

A zero reset input from an external input is also possible. The setting can be made any number of times.

The main digital display's reading becomes zero.

The Zero Reset indicator (green) lights up. The linear output becomes the center value between the 2 points set by monitor focus. Default: 0V, 12mA

- * The maximum display value on the minus size during zero reset is -19999.
- * If the zero reset memory function is enabled (it is enabled by default), the zero reset value is saved.
- * If zero reset is necessary for judgment of each work piece, turn the zero reset memory OFF.

■ Cancellation method

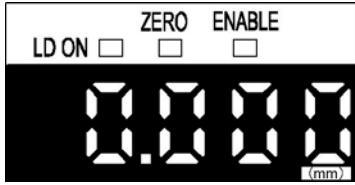

Press the ENT key and RIGHT key simultaneously for 3 sec. or more.

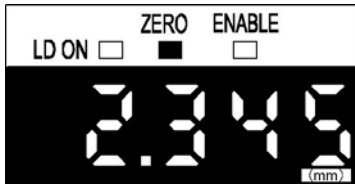

Set the mode select switch in the RUN position.



RUN THR FUN

Press the ENT key and RIGHT key simultaneously for 3 seconds or more when zero reset is being executed.

It is also possible to input zero reset by external input. The setting can be made any number of times.

The display will return to the previous display. The zero reset indicator (Green) will go off.

* Numerical values in the figures are display examples.

By using the zero reset memory function, it can be selected whether the zero set level is retained in memory.

If storing of the zero reset in memory is selected, the zero reset level data are written to the EEPROM. However, the write life of the EEPROM is 100,000 times, so if zero reset is used frequently, set the zero reset memory function on disabled in order to protect the memory.

The default setting when the product is shipped from the factory is disabled.

See '3.8.18 Zero Reset Memory Function' for the setting method.

Please

Example of the display value and linear output during zero reset.

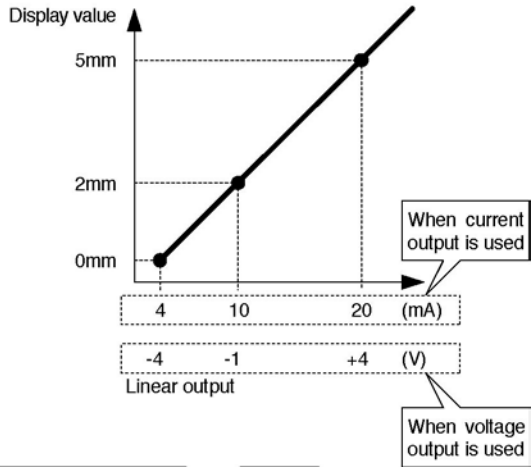

In case of zero reset at 2mm

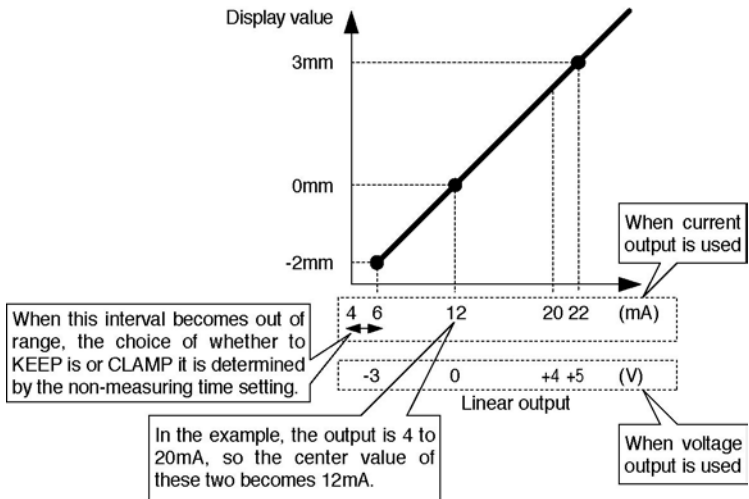
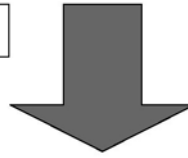

Example of Zero Reset during Measurement

For example, if you desire to evaluate the level difference in this detection object.

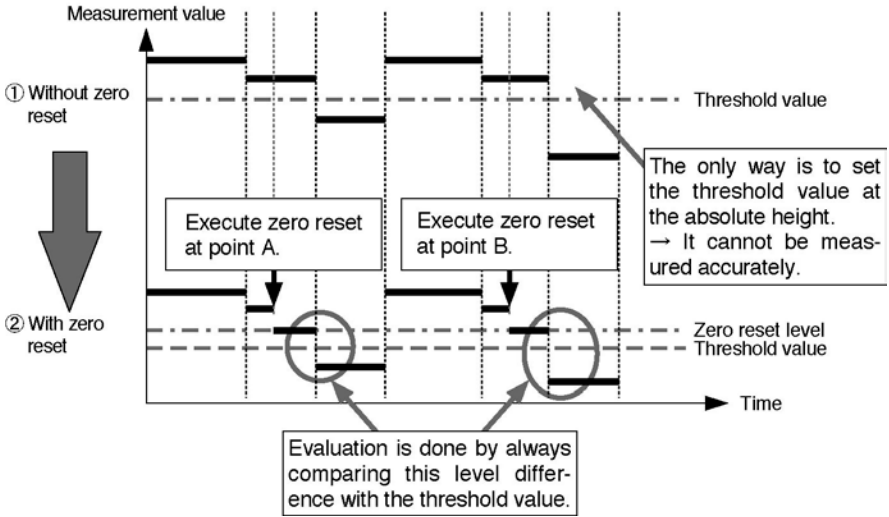
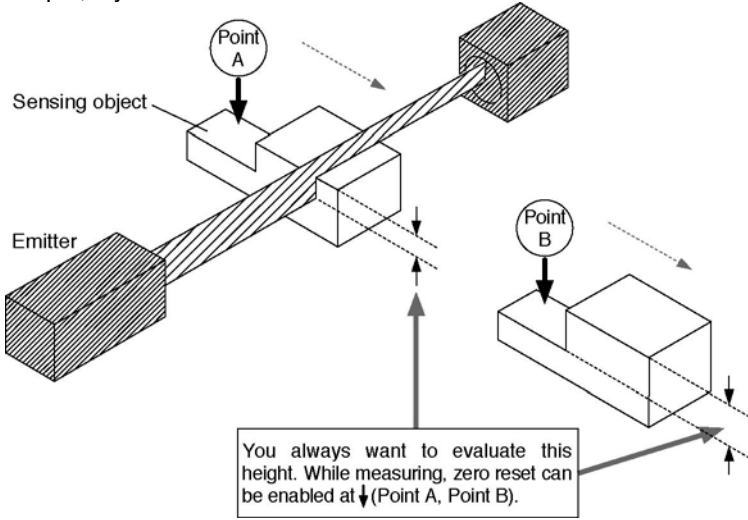

In this case, it is recommended that zero reset memory be disabled.

Reference» See '3.8.18 Zero Reset Memory Function' concerning the setting method.

3.5.4 Setting the standard laser beam reception intensity

This function registers and stores the current laser beam reception volume in memory as the standard laser beam reception intensity.

Set this setting in the full laser beam entry state. The laser beam reception intensity during full laser beam entry becomes the 100% laser beam reception intensity full scale (F.S.).

If this function is used, the display and the linear output are set on the full scale (F.S.) automatically. (The linear output becomes the full scale of the value set by Monitor Focus.)

It can also be used to correct the laser beam reception intensity when there is a change in the laser beam reception intensity due to dirt, etc. on the front glass.



Example: Laser beam reception intensity 83.23% display, output



Execute the standard laser beam reception intensity setting. In the full laser beam entry state, press the DOWN key for 3 seconds or more.

Laser beam reception intensity 100% display, output

■ Setting method

Set the full laser beam entry state.

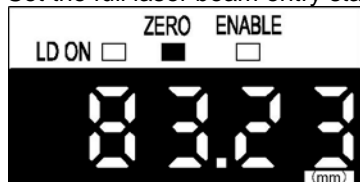

Press the DOWN key for 3 sec. or more

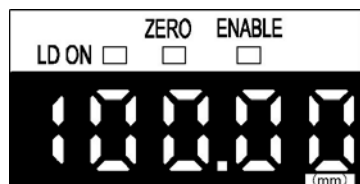

* Numerical values in the figures are display examples.

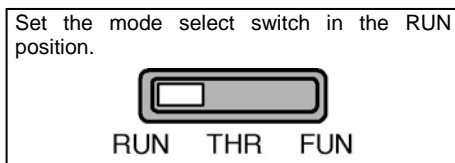

Set the mode select switch in the RUN position.

Press the DOWN key for 3 seconds or more while zero reset is not being executed.

The value in the figure is for the case where the auto scaling setting is 100-L. If the laser beam reception intensity is displayed in mm units, this setting becomes the maximum value. Also, if the laser beam interrupted intensity display (- d) is selected, it becomes 0. If the linear output is set by monitor focus, that becomes the setting value.

* The standard laser beam reception intensity is stored in memory. The next time the power is turned on, the set standard laser beam reception intensity is read out.



Perform this setting after the auto scaling setting is completed. If auto scaling is reset after setting the standard laser beam reception intensity, the standard laser beam reception intensity will be canceled.

3.5.5 Other functions in the RUN mode

■ Timing input

Press the UP key (▲) and execute timing input control. The timing input is enabled only if the hold function is enabled. It is also possible to use a timing input from an external input line.

3.6 THR (Threshold) Mode

In this mode, the threshold values are decided.

The following tasks can be performed.

- Direct input of threshold values
- Teaching of positioning points
- 2-point teaching
- Automatic teaching

The HIGH threshold value is set by setting the threshold value select switch on 'H' and the LOW threshold value is set by setting the threshold value select switch on 'L'. The threshold select switch is invalid for automatic teaching.

Set the Mode Select switch in the THR position.

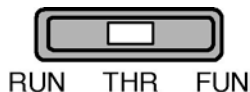

Select the threshold value that is to be input by teaching or direct input using the threshold value select switch.



If the HIGH threshold value is set lower than the LOW threshold value, it results in an error.

Set the HIGH threshold value so that it is greater than the LOW threshold value.

Please

Also, if the hysteresis (Hys) is too great, and the $(\text{HIGH threshold value} - \text{LOW threshold value}) < \text{Hys}$, it will be impossible to get a PASS judgment, so the setting will be no good. Also, if the threshold value is outside the sensor's measuring range, the setting cannot be performed.

In the teaching setting, etc., if the HIGH threshold value is not greater than the LOW threshold value due to the previously set threshold values and the teaching values, it results in an error and it may be difficult to set the settings well.



In this case, set the HIGH threshold value on the full scale (F.S.) upper limit value, and set the LOW threshold value on the bottom value (zero), then perform threshold value setting or teaching. It will then be easy to set the threshold values.

3.6.1 Direct threshold value input

It is also possible to input the threshold values directly into the sub-digital display. The main digital display displays the measurement value and the sub-digital display displays the threshold value. The threshold values set by the teaching function can also be fine adjusted.

Please

Ordinarily, any numbers can be input, but if threshold values which are outside the measuring range are input, the judgment output will not function, so exercise caution. Also, the decimal point position cannot be changed.

Changing the numerical value

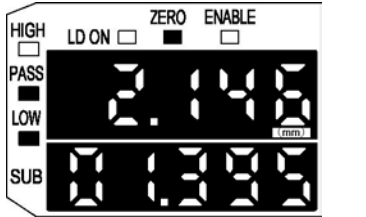

Press the UP, DOWN, LEFT or RIGHT key.

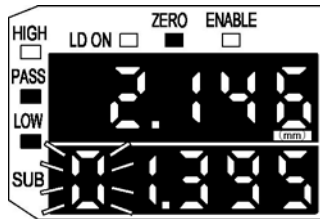

Set the mode select switch in the THR position.



RUN THR FUN

Select the threshold value that is to be input by teaching or direct input using the threshold value select switch.

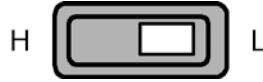

Press the UP, DOWN, RIGHT or LEFT key.

This will start the direct input.

The top digit in the sub-digital display, which is the highest digit in the threshold value, will blink. Change the numerical values as shown on the next page.

* Numerical values in the figures are display examples.

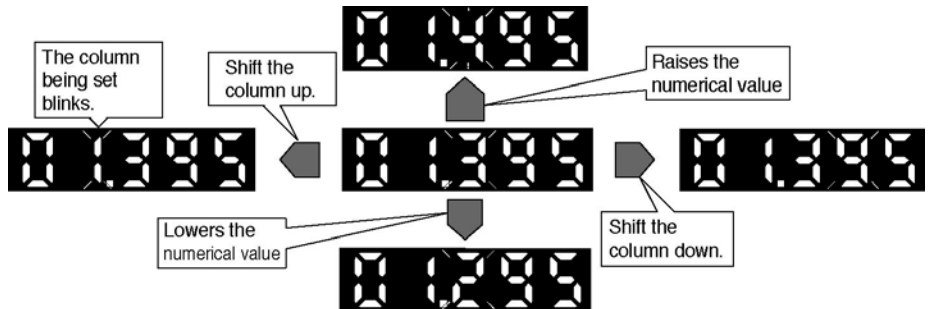

■ Fixing the numerical value

The numerical values are not set when they are blinking and are not saved in that state. Set the values using the following method.

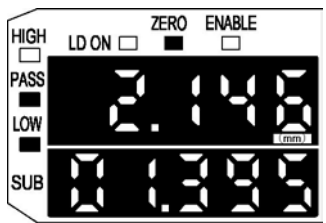

When adjustment of the numerical value is finished, press the ENT key to fix the values.

↓  Press the ENT key.

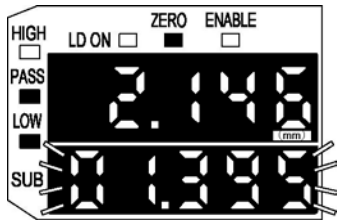

All the digits in the sub-digital display will blink 2 times.

↓ The number will blink 2 times, then will remain lighted up.

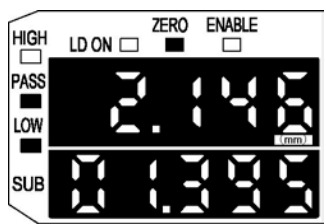

The sub-digital display will then remain on and the numerical value will be set. The value is saved in the EEPROM.

↓ Setting is ended.

* Numerical values in the figures are display examples.



If the mode is changed by moving the Mode Select switch while the numerical value is blinking, or if the threshold value select switch is changed, the change in the threshold values is canceled.

3.6.2 Teaching

Teaching is the procedure for determining the threshold values automatically by obtaining data from the actual use environment or detection object and carrying out internal calculations in the sensor. After teaching, it is also possible to fine adjust the threshold values and perform teaching again.

The setting methods include 3 different types, 'Positioning Teaching', '2-point Teaching' and 'Automatic Teaching'.

3.6.3 Teaching positioning

The measurement value acquired during teaching becomes the threshold value.

■ Example of teaching positioning

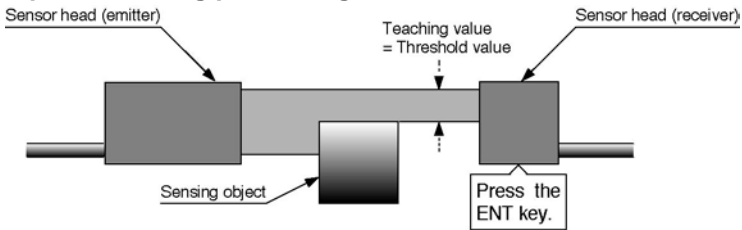

■ Setting method

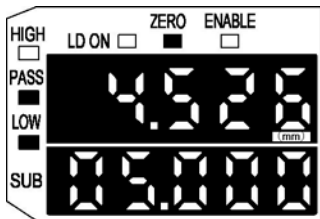

Set the mode select switch in the THR position.

RUN THR FUN

Select the threshold value that is to be input by teaching or direct input using the threshold value select switch.

H L

Set the work piece, then with the sub-digital display lighted up, press the ENT key for approximately 1 second.

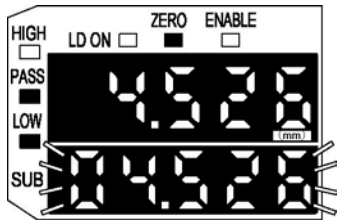

The work piece's measurement value will be displayed in the sub-digital display and will blink 2 times. (All the digits will blink together.)

↓
The number will blink 2 times, then will remain lighted up.

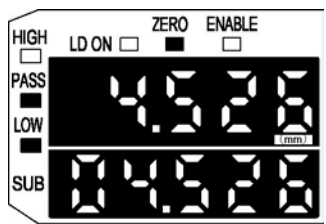

After the sub-digital display blinks 2 times, it will remain light up, and the threshold value will be set.

↓
End setting.

* Numerical values in the figures are display examples.



If there is a teaching error, the threshold value is not changed.

3.6.4 2-point teaching

The center point between teaching points 1 and 2 becomes the threshold value. Using this method, minute level differences in the sensing object, such as differences equivalent to the thickness of a sheet of paper, can be judged.

■ Example of 2-point teaching

1st point

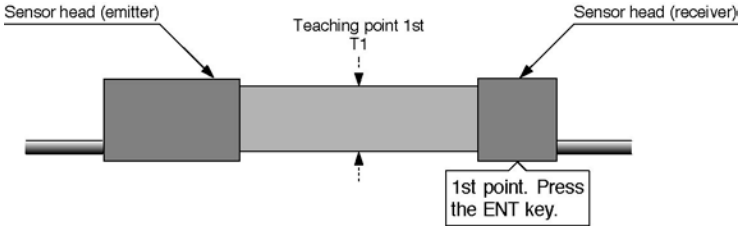

2nd point

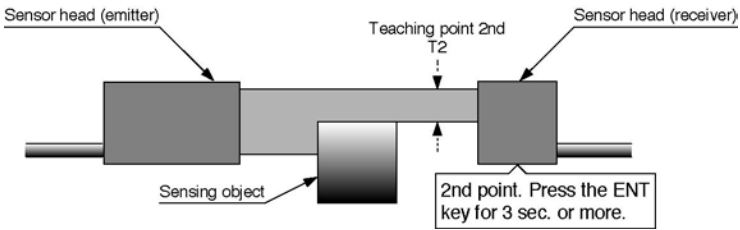

Threshold value

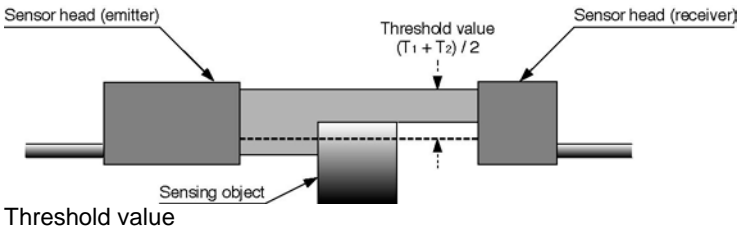

■ Setting method

① Teaching the 1st point

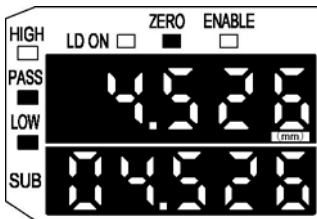
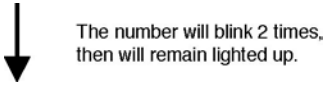
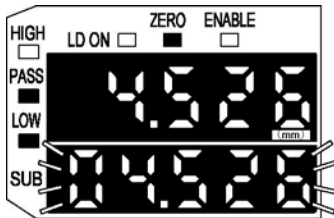
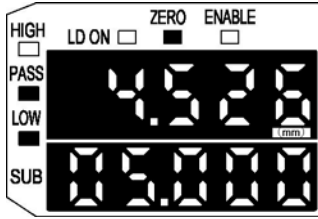

* Numerical values in the figures are display examples.

Set the mode select switch in the THR position.



RUN THR FUN

Select the threshold value that is to be input by teaching or direct input using the threshold value select switch.



Set the work piece, then with the sub-digital display lighted up, press the ENT key for approximately 1 second.

The measurement value for the work piece will be displayed in the sub-digital display and blink 2 times. (All the digits will blink at once.)

After the sub-digital display blinks 2 times, it will remain lighted up and the threshold value will be set.



POINT

If there is a teaching error, the threshold value is not changed.

② Teaching the 2nd point

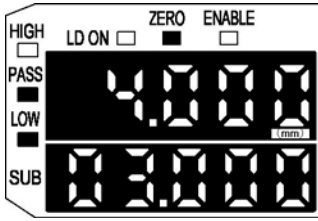

Press the ENT key for 3 sec. or more.

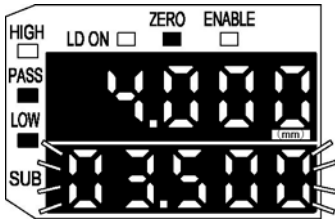

The number will blink 2 times, then will remain lighted up.

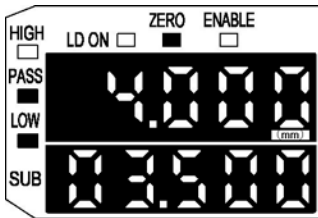

When setting of the 1st threshold value is completed, set the work piece for the 2nd point, then press the ENT key for 3 seconds or more.

The center value between the 1st point and the 2nd point on the work piece will be displayed in the sub-digital display and will blink 2 times.

After the sub-digital display blinks 2 times, it will remain lighted up and the threshold value will be set.

③ End setting.

* Numerical values in the figures are display examples.



If there is a teaching error, the threshold value is not changed.

3.6.5 Automatic teaching

Measurement is executed while the RIGHT key and the ENT key are pressed simultaneously, then the maximum and minimum measurement values are set as the threshold values. The threshold value can be set according to the detected object.

The threshold value is entered when the keys are released. The position where the maximum intensity of laser beam is detected is set as the HIGH threshold value, and the position where the minimum intensity of laser beam is detected is set as the LOW threshold value.

(Note): The settings of the hold mode, trigger mode, and scaling that have been set are also reflected in the measurement during teaching.

■ Example of automatic teaching

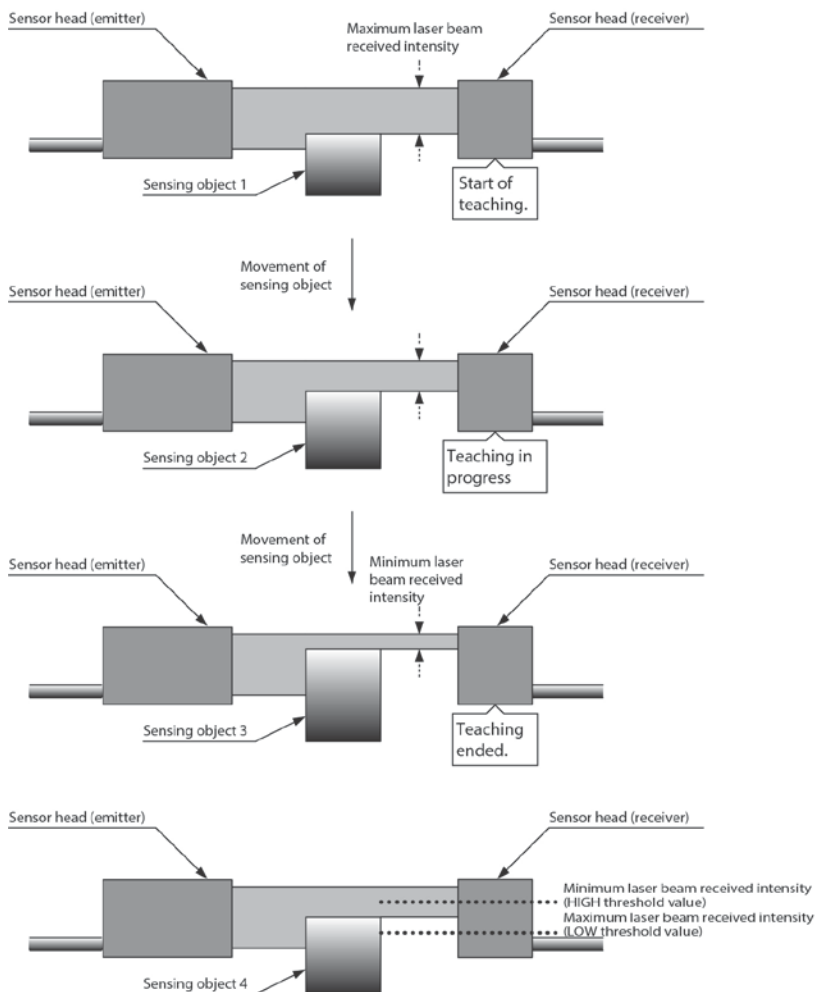

■ Setting method

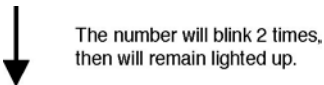
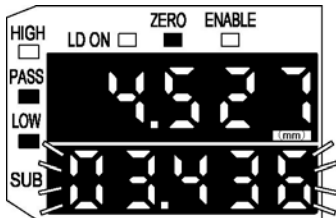
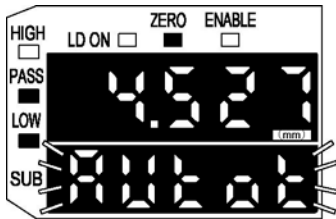
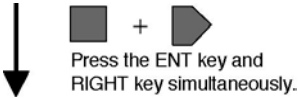
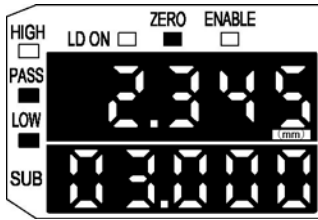

Press the ENT key and RIGHT key simultaneously while the work pieces are moving.

If the keys are pressed for 1 second or more, 'Auto' is displayed in the sub-digital display and blinks.

(Sampling starts immediately after the keys are pressed.)
Sampling continues while the keys remained pressed down.

Release the keys.

At the instant the keys are released, the center value of the maximum and minimum sampled measurement values is set automatically as the threshold value.

The automatically set threshold value is displayed in the sub-digital display and blinks 2 times.

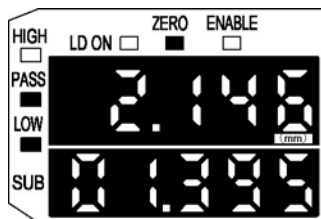

The sub-digital display remains lighted up after blinking 2 times, and the threshold value is set.



End setting.

* Numerical values in the figures are display examples.



- The threshold value blinking in the display is not changed. The measuring processing done for the previous threshold value continues.
- If there is a teaching error, the threshold value is not changed.
- In the case of the automatic teaching, the result is not dependent on the position of the threshold select switch. Whether the switch is set to H or L, the both HIGH and LOW threshold values are set.
- The threshold value set by the automatic teaching can also be changed by the direct input. See "3.6.1 Direct threshold value input".

3.7 FUN (Function) Mode

3.7.1 Basic operation

The settings for each function are set in this mode.

There is a wide variety of setting items, but basically, the operating method is shown on the next page.

In this mode, the linear output and judgment output are output regardless of the KEEP/CLAMP setting set in the RUN mode's non-measuring time setting. (The KEEP state.)

3.7.2 Basics of mode changes

The basics of mode changes are as shown below.

- (1) RIGHT key '▶' Changes items in the forward direction.
- (2) LEFT key '◀' Changes items in the reverse direction.

(Example) Changing modes in the forward direction

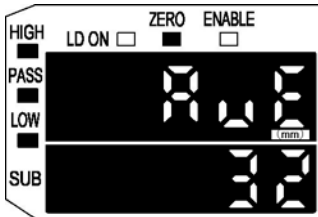

↓ ▶
Pressing the RIGHT key changes the mode in the forward direction.

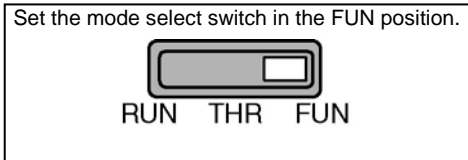
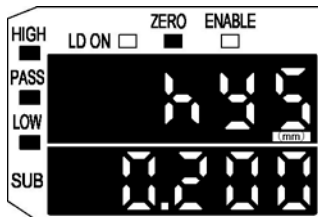

Change the mode by pressing the RIGHT key (forward direction) or the LEFT key (reverse direction).

The current setting value is displayed in the sub-digital display.

3.7.3 Changing setting values (other than numerical values)

The method for changing the desired mode setting values (other than numerical values) is as shown below.

(Example) Changing the hold setting

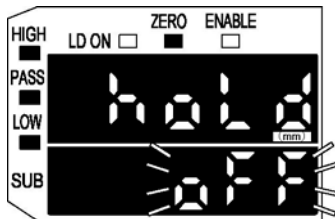
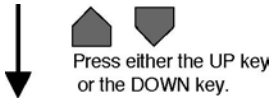
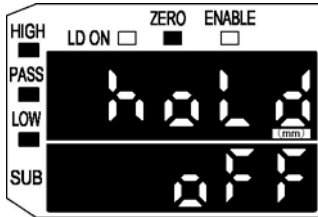

Using the method described in '3.7.2, **Mode setting basics**' change to the mode where you desire to change the settings.

Press either the UP or DOWN key to start the setting change.

The current setting value is displayed in the sub-digital display, in the blinking state.

Change the setting value as shown below.

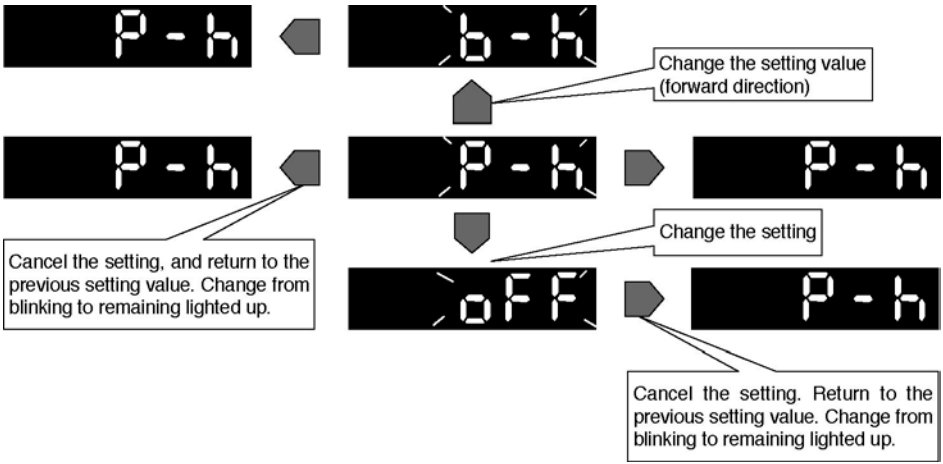

■ Set the setting value

If the setting value remains in the blinking state, it will not be set, and is not saved.

Set the setting value by the following method.

(Example)

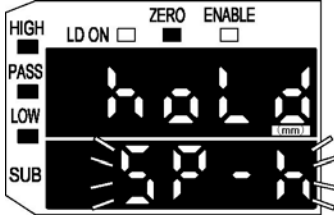

↓ Press the ENT key.

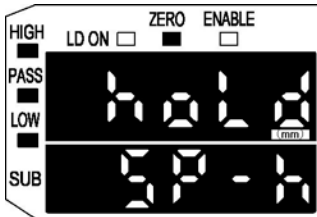

↓ End setting.

When selection of the setting value is completed, press the ENT key to set the setting value.

The sub-digital display will change from blinking to remaining lighted up and the setting value will be set.

The setting value is saved to EEPROM.

3.7.4 Changing setting values (in case of numerical values)

The method for changing the desired mode setting values (numerical values) is as shown below.

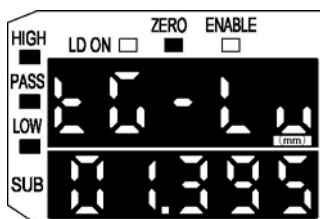

Using the method described in '3.7.2, Mode setting basics' change to the mode where you desire to change the settings.

Press either the UP or DOWN key to start the setting change.

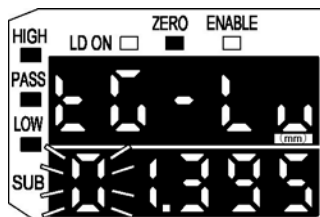
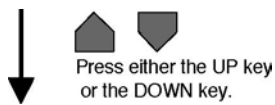

The numerical value in the top digit position displayed in the sub-digit display is displayed in the blinking state.

Change the setting value as shown below.

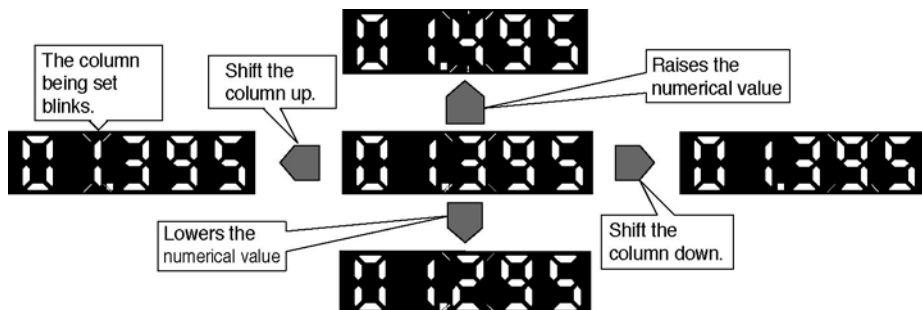

However, if the LEFT key is pressed while the numerical value in the top digit is blinking, or if the RIGHT key is pressed while the numerical value in the bottom digit is blinking, the setting is canceled and the previous setting value is displayed.

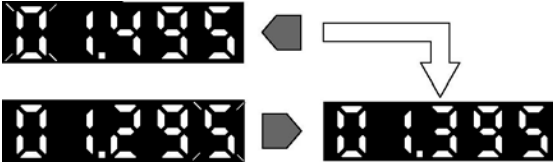

The setting is canceled and the setting value returns to the previous value. The display changes from blinking and remains lighted up.

■ Setting the numerical value (when normal)

If the numerical value remains in the blinking state, it will not be set, and is not saved.

Set the numerical value by the following method.

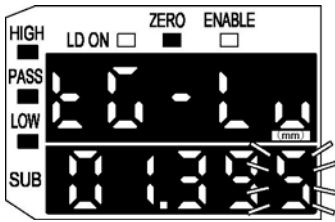

When adjustment of the numerical value is finished, press the ENT key.

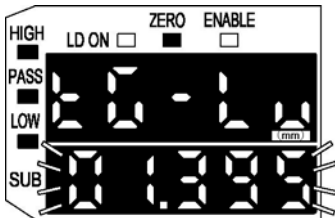

All the digits in sub-digital display will blink 2 times.

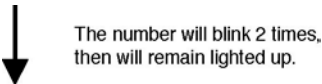

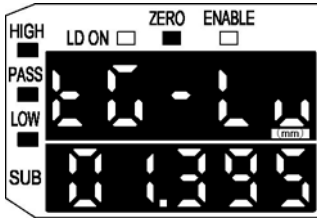

The sub-digital display then remains lighted up.
The numerical value is saved in EEPROM.



End Setting.

* Numerical values in the figures are display examples.

■ Setting the numerical value (when abnormal)

The setting error conditions are as shown below.

- (1) The value that you attempted to set was too large.
- (2) The value that you attempted to set was too small.

Depending on the conditions, the message shown in the figure below is shown 3 times in the sub-digital display at 1 second intervals. The setting value prior to the change is shown in the display.

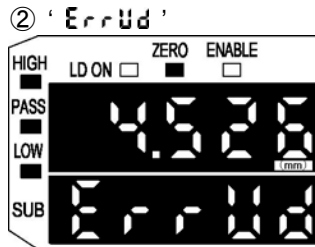
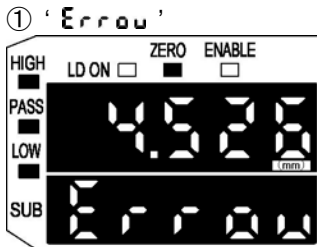

The error message is displayed when the ENT key is pressed.

3.8 Functions That Can Be Set In The FUN Mode

3.8.1 Auto scaling function

The auto scaling function selects whether to display the laser beam reception intensity in the main-digital display in mm units or in % units, and determines whether the intensity of laser beam received or the intensity of laser beam interrupted is displayed.

With the set standard laser beam reception intensity as the reference value, the current laser beam reception intensity (laser beam interrupted intensity) is scaled automatically and is displayed as well as being output.

In the default state as shipped from the factory, 100-L is set.

CHAPTER 3

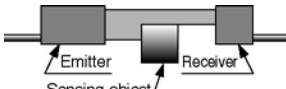
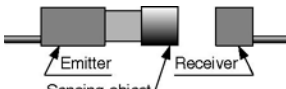
		5-L	5-d	10-L	10-d	30-L	30-d	100-L	100-d
When full laser beam is received 	Display	5.000	0.000	10.000	0.000	30.000	0.000	100.00	0.00
	Linear	+4V	-4V	+4V	-4V	+4V	-4V	+4V	-4V
	Output	20mA	4mA	20mA	4mA	20mA	4mA	20mA	4mA
When laser beam is interrupted 	Display	2.500	2.500	5.000	5.000	15.000	15.000	50.000	50.000
	Linear	0V	0V	0V	0V	0V	0V	0V	0V
	Output	12mA	12mA	12mA	12mA	12mA	12mA	12mA	12mA
When full laser beam is interrupted 	Display	0.000	5.000	0.000	10.000	0.000	30.000	0.00	100.00
	Linear	-4V	+4V	-4V	+4V	-4V	+4V	-4V	+4V
	Output	4mA	20mA	4mA	20mA	4mA	20mA	4mA	20mA

Notes: 1) 100-L and 100-d display the laser beam reception intensity (laser beam interrupted intensity) in % units.

2) Linear output is the value when the monitor focus function is not being used.

3) If scaling to values other than 5, 10 and 30mm is desired, use the 2-point scaling function after setting auto scaling.

4) Perform the monitor focus setting after the auto scaling setting.

Please

If the auto scaling function is set, all the settings return to the default values set at the factory, so exercise caution.

■ Setting procedure

The procedure for performing the auto scaling setting is shown in the following figure.

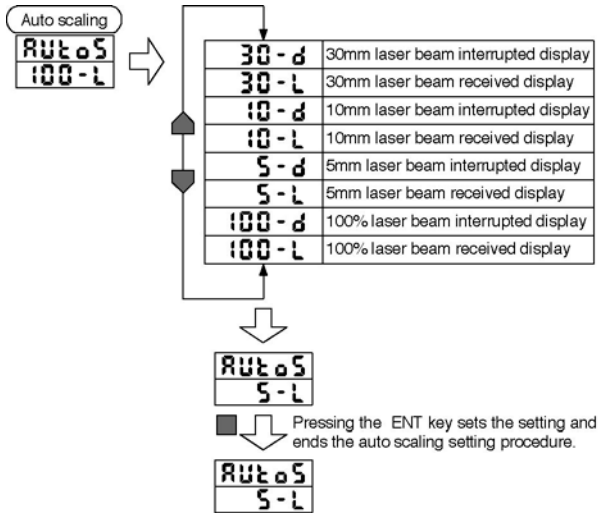

* Numerical values in the figures are display examples.

3.8.2 Scaling function

The scaling function is a function that changes the display value the desired amount with respect to the setting value. At the desired distance, the display value can be input and changed.

If 1-point scaling is done, the display value's span is not changed and only the offset becomes changed.

If 2-point is done, both the display value's span and the offset are changed.

[1-point Scaling]

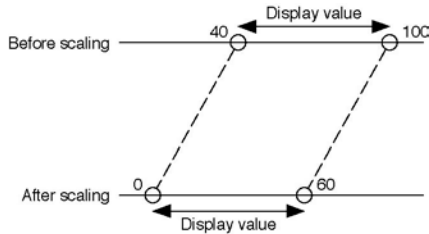

The span is not changed, but the offset can be changed.

[2-point Scaling]

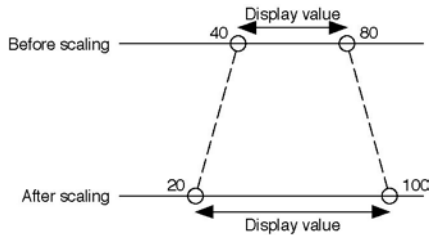

The span and the offset can be changed.

Please

However, in the end it is the display value with respect to the measurement value that is changed with this function, and the linear output with respect to the measurement value is not changed, so exercise caution.

● Relationship between measurement value and linear output

The relationship between the measurement value and the linear output is set by the monitor focus function, so when you desire to change the linear output value, perform the monitor focus setting after performing the scaling setting.

Reference» See '3.8.10 Monitor focus function' for the details the monitor focus setting.

● Display inverse

If inverse is enabled, then the method of increasing or decreasing the value in the display with respect to the reference value is reversed. For example, in the case of the intensity of laser beam entering display, ordinarily, if the intensity of laser beam entering increases, the display value increases, but when inverse is enabled, the value becomes smaller as the intensity of laser beam entering increases. However, in 2-point scaling, inverse is disabled.



If the following changes are made, the scaling value is cleared automatically. In such a case, perform the scaling setting again.

- If the adjacent sensor calculation A+B is changed from enabled ⇔ disabled.
- If the adjacent sensor calculation A-B is changed from enabled ⇔ disabled.
- If the adjacent sensor calculation thickness measurement is changed from enabled ⇔ disabled.
- When auto scaling is reset.



In the following cases, this setting causes the scaling setting to be NG, and scaling cannot be used.

- If the 2-point scaling interval is less than 10% of the full scale (F.S.).
- If the numerical value input for scaling is extremely small, or extremely large.

■ Setting procedure

The procedure for performing the scaling setting is as shown below.

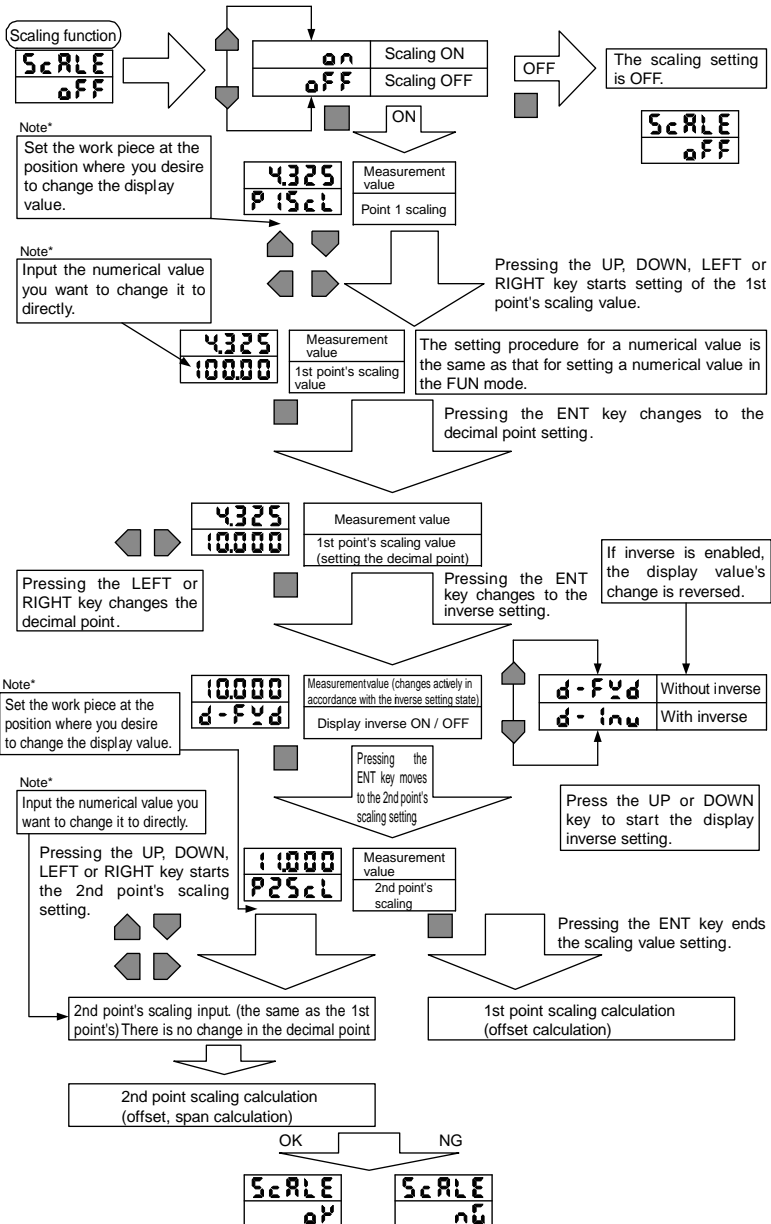

* Numerical values in the figures are display examples.

Note* Take care that if the user does not follow this procedure, the scaling result is failure.

■ **If you desire to offset the display value (1-point scaling A)**

If you desire to offset the display value, use 1-point scaling.

Input the value that you want to be recognized with respect to the current measurement value.

If 1 point only is input without inverse being enabled, the offset only is changed without changing the display value's span.

Example of 1-point scaling A

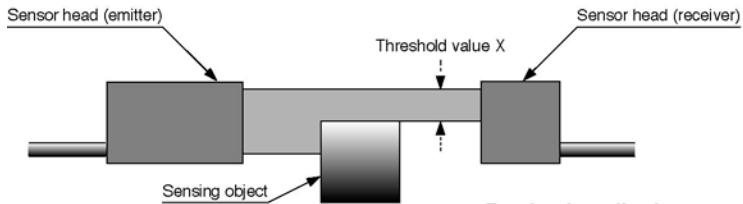

Desired to display
Threshold X = 2.5mm
as 5mm

In such a case:

Before scaling
Measurement value = Display value
1.5
2.0
2.5
3.0

After scaling	
Display value	Measurement value
4.0	1.5
4.5	2.0
5.0	2.5
5.5	3.0

2.5mm is displayed as 5.0mm.

: Scaling input value
The values are shifted.

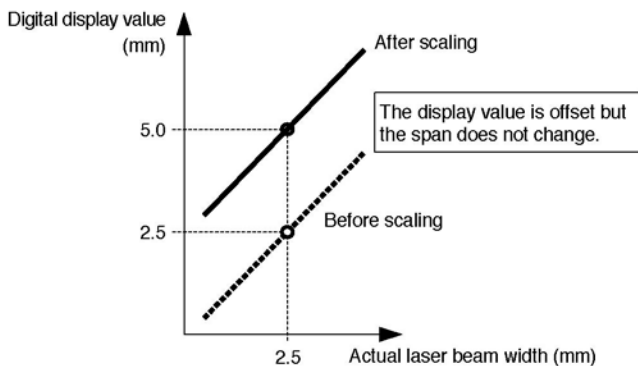

■ If you desire to correct the display value to the actual width (2-point scaling A)

If there is deviation between the actual laser beam received width and the controller's display value, a correction can be made. In case that the true width is known in advance, input that value for 2 points, then the span and offset of the display value will be corrected. (See the figure below.)

Reference▶▶ If you desire to change the offset only without changing the span of the display value, see '■ If you desire to offset the display value (1-point scaling A)'.

Example of 2-point scaling A

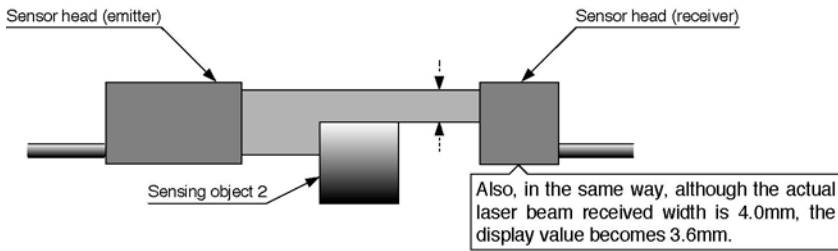
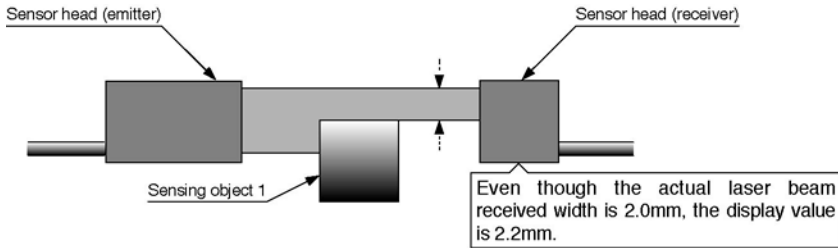

In such a case:

■ : Scaling input value

Before scaling	
Actual light received width	Measurement value = Display value
2.0	2.20
2.5	2.55
3.0	2.90
3.5	3.25
4.0	3.60

After scaling		
Actual light received width	Display value	Measurement value
2.0	2.0	2.20
2.5	2.5	2.55
3.0	3.0	2.90
3.5	3.5	3.25
4.0	4.0	3.60

It is corrected. Now they match.

There is deviation between the actual laser beam received width and the display value.

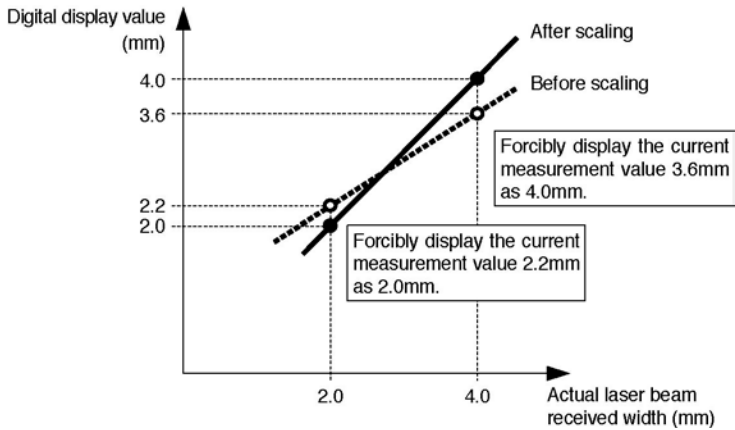

■ If you desire to use the desired display value (2-point scaling B)

Using the same method as 2-point scaling A, the desired display value can be used. Input the desired values for the 2 points you want to be recognized, and the span and offset of the display value can be changed. (See the figure below.)

Example of 2-point Scaling B

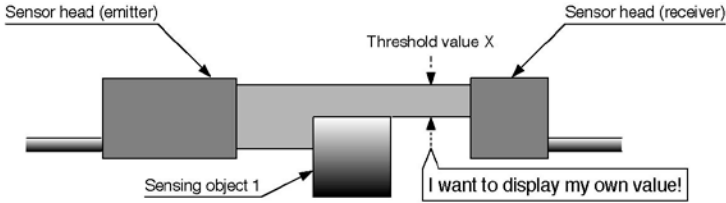

If you desire to display
120mm when the measurement value $x = 2\text{mm}$
80mm when the measurement value $x = 4\text{mm}$

In such a case:

Before scaling
Measurement value = Display value
2.0
3.0
4.0
5.0

After scaling	
Display value	Measurement value
120.0	2.0
100.0	3.0
80.0	4.0
60.0	5.0

Display 2.0mm as 120mm
Display 4.0mm as 80mm

Both the span and offset are changed.

█ : Scaling input value

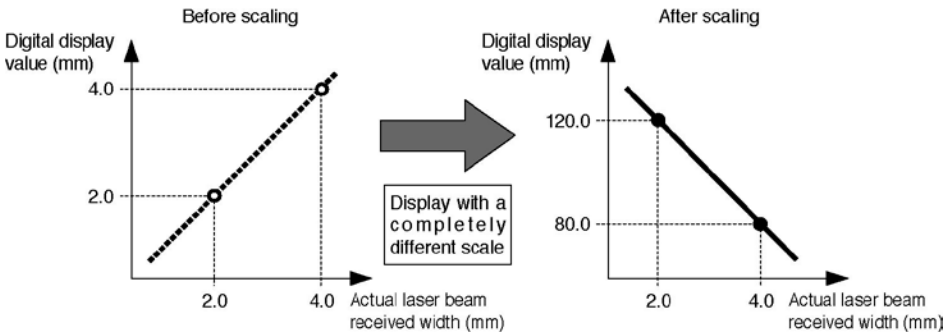

3.8.3 Average sampling rate

This is the number of data points when averaging data measured by the sensor. In case of minute positioning or discrimination, the make the average sampling rate large and suppress variations. However, when this is done, the judgment output and linear output time become slow.

The relationship between the average sampling rate and the response time is shown in the following table.

Relationship between average sampling rate and response time

Average sampling rate	Response time (ms)
1	0.3
2	0.5
4	0.8
8	1.5
16	2.5
32	5
64	10
128	20
256	40
512	75
1,024	150
2,048	300
4,096	600

* Ordinarily, if the average sampling rate is increased n times, the resolution improves \sqrt{n} times.

■ Setting method

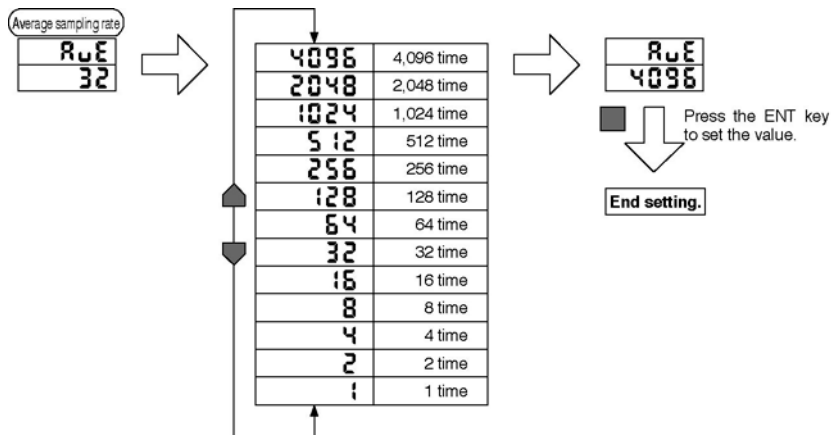

* Numerical values in the figures are display examples.

3.8.4 Hysteresis width setting

This setting determines the hysteresis (hysteresis width) of the threshold values. The desired value can be input directly or the auto hysteresis setting can be used.

■ Direct input

Input the hysteresis width value directly.

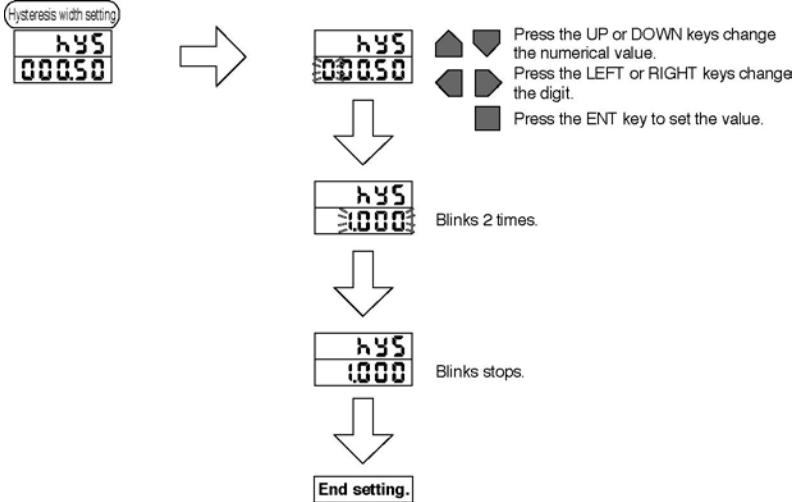

■ Auto hysteresis setting



If the auto hysteresis setting is used, the hysteresis is set automatically so that it becomes approximately 2 times the resolution.

* Numerical values in the figure are setting examples.



If the hysteresis (Hys) is too great, and $(\text{HIGH threshold value} - \text{LOW threshold value}) < \text{Hys}$, it will become impossible to get a PASS judgment, so the setting cannot be done. Make the hysteresis setting value smaller so that the above conditions do not occur.

3.8.5 Hold

This function extracts data of special points in the display values (maximum or minimum values, etc.), outputs and displays them.

There are 5 types of hold, peak hold, bottom hold, sample hold, peak to peak hold, and average hold.

Cautions when the hold mode is enabled are as follows.

Please

- (1) During hold sampling (when the timing input is ON) or if ' - - - - - ' is displayed in the main display, the zero reset input is disabled.
- (2) If the non-measuring state occurs during hold sampling (when the timing input is ON) (when reset is being input or when the laser beam reception intensity is abnormal), the data are omitted from the sampling during that time. Sampling continues until the timing input goes Off. Also, if the laser beam reception intensity is abnormal at all times during sampling, ' E r r o r ' is displayed during hold.
- (3) The timing input is necessary during execution of each hold mode, including peak, bottom and peak to peak hold.
- (4) Do not enable the timer function during hold.



When the hold mode is started and un until the first measurement is ended, the following conditions are fixed.

Linear output: Set clamp value

Judgment output: All Off

Main-digital display: ' - - - - - '



If the hold value is cleared and measurement is done again, input the reset signal.

■ Setting method

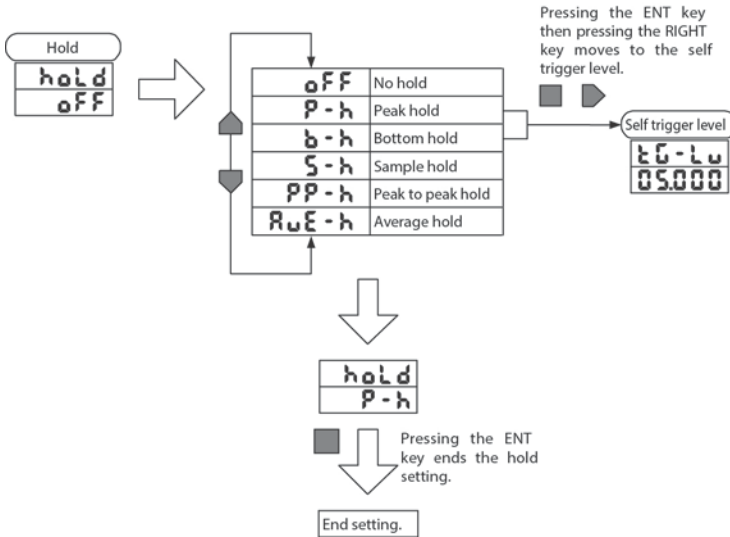

Inputting the self trigger level value.

■ Normal (no hold): oFF

The value that is currently being measurement is always displayed and output.

When the timing input is disabled, the hold function does not operate.

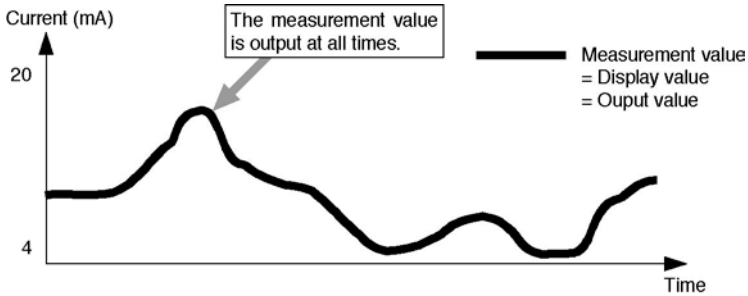

■ Peak hold: P - h

This holds the maximum value in the measurement values. During the hold mode, the maximum value is sampled during the period when the timing input is ON.

The hold mode starts immediately after the power is turned on, or switching to the RUN or THR mode occurs, or immediately after the reset input has changed from ON to OFF. After the hold mode is started and up to the time that the 1st measurement is completed, the clamp value is output.

When the timing input changes from ON to OFF, the maximum value sampled during the sampling interval is output. After the 1st measurement is completed and up to the time that the 2nd measurement is completed, the results of the 1st measurement are held (Value A in the figure below) and output. Up until the 2nd measurement is completed, the results of the 2nd measurement (Value B in the figure below) are held and output. Thereafter, this process is repeated.

Example of peak hold

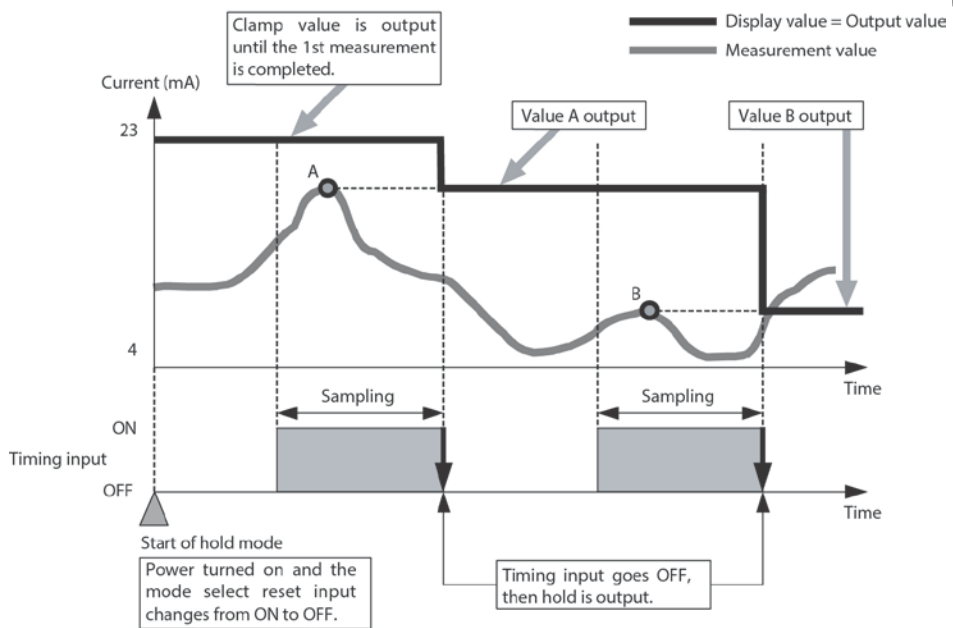

(Note) The above figure shows the case where the clamp value is set to the maximum current value, 23 mA. The clamp value can be arbitrarily set.
 Voltage value: -5 V to 5 V or approx. 5.5 V
 Current value: 3 to 21 mA or approx. 23 mA

■ Bottom hold: $b - h$

This holds the minimum value in the measurement values. During the hold mode, the minimum value is sampled during the period when the timing input is ON.

The hold mode starts immediately after the power is turned on, or switching to the RUN or THR mode occurs, or immediately after the reset input has changed from ON to OFF. After the hold mode is started and up to the time that the 1st measurement is completed, the clamp value is output.

When the timing input changes from ON to OFF, the minimum value sampled during the sampling interval is output. After the 1st measurement is completed and up to the time that the 2nd measurement is completed, the results of the 1st measurement are held (Value A in the figure below) and output. Up until the 2nd measurement is completed, the results of the 2nd measurement (Value B in the figure below) are held and output. Thereafter, this process is repeated.

Example of bottom hold

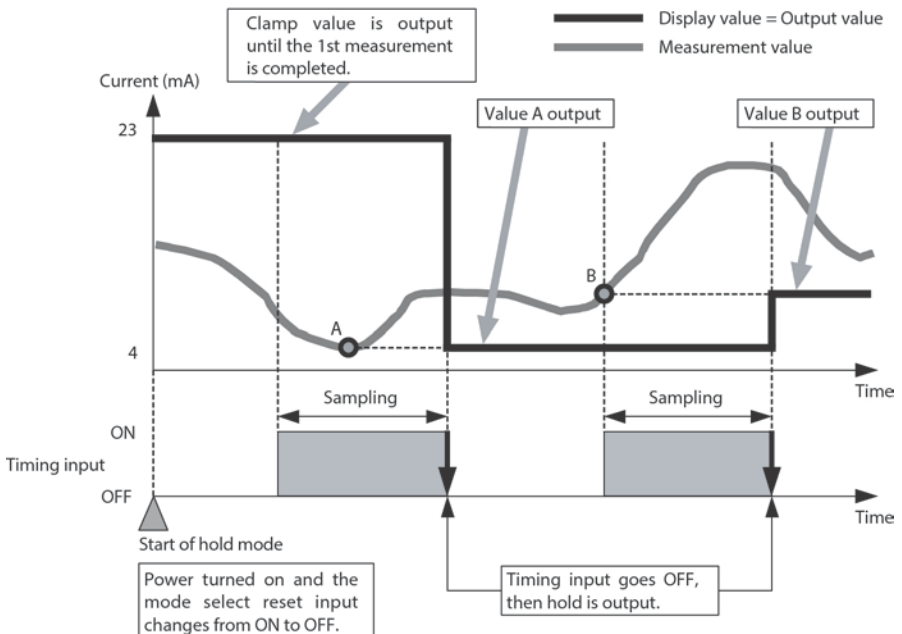

(Note) The above figure shows the case where the clamp value is set to the maximum current value, 23 mA. The clamp value can be arbitrarily set.

Voltage value: -5 V to 5 V or approx. 5.5 V

Current value: 3 to 21 mA or approx. 23 mA

■ **Sample hold: S - h**

This holds the measurement value from the point when the timing input is input. During the hold mode, the measurement value sampled at the instant when the timing input changed from OFF to ON is held.

The hold mode starts immediately after the power is turned on, or switching to the RUN or THR mode occurs, or immediately after the reset input has changed from ON to OFF. After the hold mode is started and up to the time that the 1st measurement is completed, the clamp value is output.

After the 1st measurement is completed and up to the time that the 2nd measurement is completed, the results of the 1st measurement are held (Value A in the figure below) and output. Up until the 2nd measurement is completed, the results of the 2nd measurement (Value B in the figure below) are held and output. Thereafter, this process is repeated.

Example of sample hold

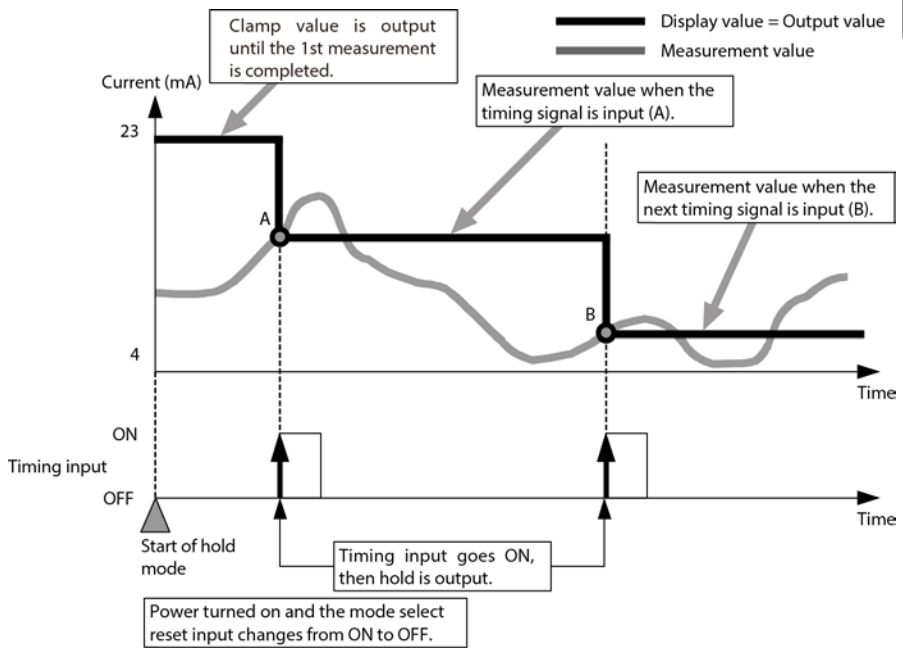

(Note) The above figure shows the case where the clamp value is set to the maximum current value, 23 mA. The clamp value can be arbitrarily set.
 Voltage value: -5 V to 5 V or approx. 5.5 V
 Current value: 3 to 21 mA or approx. 23 mA

■ Peak to peak hold: $P_P - h$

This holds the measurement value [Maximum value - Minimum value]. During the hold mode, the maximum and minimum values are sampled during the period when the timing input is ON.

The hold mode starts immediately after the power is turned on, or switching to the RUN or THR mode occurs, or immediately after the reset input has changed from ON to OFF. After the hold mode is started and up to the time that the 1st measurement is completed, the clamp value is output.

When the timing input changes from ON to OFF, the [maximum value - minimum value] sampled during the sampling interval is output. After the 1st measurement is completed and up to the time that the 2nd measurement is completed, the results of the 1st measurement are held (P1 - B1 in the figure below) and output. Up until the 2nd measurement is completed, the results of the 2nd measurement (P2 - B2 in the figure below) are held and output. Thereafter, this process is repeated.

Example of peak to peak hold

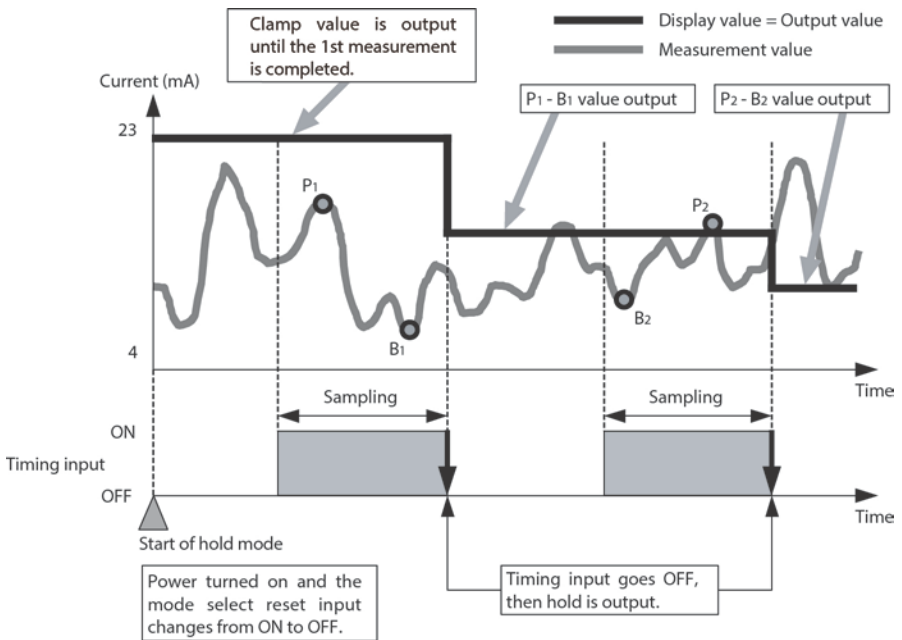

(Note) The above figure shows the case where the clamp value is set to the maximum current value, 23 mA. The clamp value can be arbitrarily set.

Voltage value: -5 V to 5 V or approx. 5.5 V

Current value: 3 to 21 mA or approx. 23 mA

■ Average hold: $R_{UE} - h$

This holds the average value in the measurement values. During the hold mode, the average value is sampled during the period when the timing input is ON.

The hold mode starts immediately after the power is turned on, or switching to the RUN or THR mode occurs, or immediately after the reset input has changed from ON to OFF. After the hold mode is started and up to the time that the 1st measurement is completed, the clamp value is output.

When the timing input changes from ON to OFF, the average value sampled during the sampling interval is output. After the 1st measurement is completed and up to the time that the 2nd measurement is completed, the results of the 1st measurement are held (Value A in the figure below) and output. Up until the 2nd measurement is completed, the results of the 2nd measurement (Value B in the figure below) are held and output. Thereafter, this process is repeated.

Example of average hold

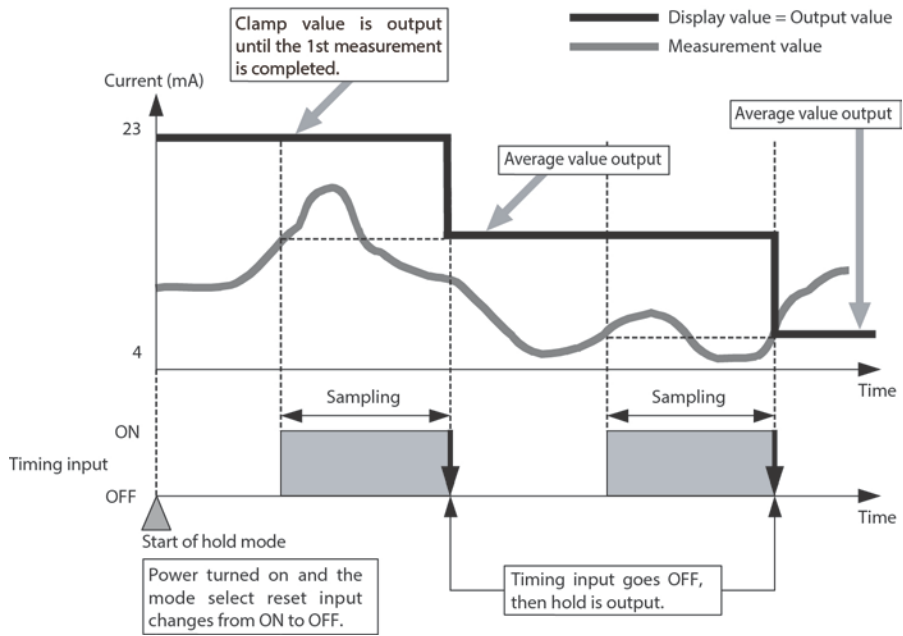

(Note) The above figure shows the case where the clamp value is set to the maximum current value, 23 mA. The clamp value can be arbitrarily set.
 Voltage value: -5 V to 5 V or approx. 5.5 V
 Current value: 3 to 21 mA or approx. 23 mA

● Self trigger level

The self trigger level is set to detect changes in measurement values and use them as trigger signals for the sampling. There are two types of self triggers.

UP (Self-up trigger)	The sampling is performed during the period that the measured value is greater than the specified threshold value.
DOWN (Self-down trigger)	The sampling is performed during the period that the measured value is lower than the specified threshold value.

* For the trigger level to finish the sampling, the hysteresis value is set.

The procedures for selecting the self-up trigger, and setting the trigger level and hysteresis are shown below.

■ Selecting Trigger Types

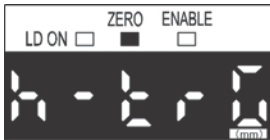

Use the LEFT or RIGHT key to display [H-TRIG] on the main display.



Press the UP or DOWN key.

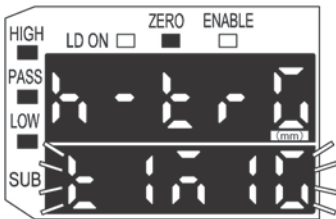

The sub-display will flash.



Press the UP or DOWN key to select the desired trigger type.

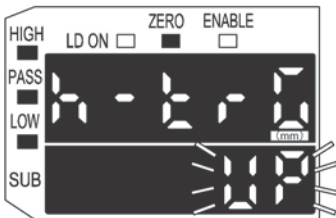

(Go to the next page)

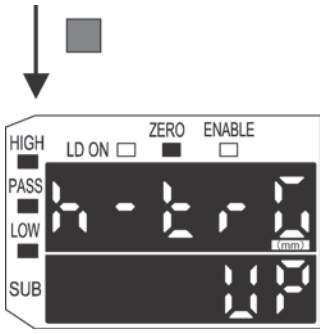

Press the ENT key to confirm the setting.

■ Setting Trigger Levels

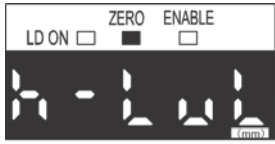

Use the LEFT or RIGHT key to display [H-LVL] on the main display.



Press the UP or DOWN key.

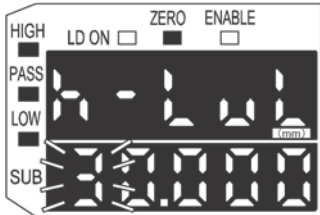

The leftmost digit of the sub-display will flash.

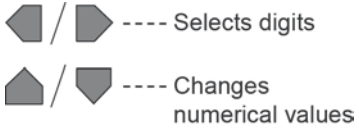

Set the desired trigger level.

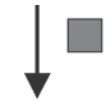

Press the ENT key to confirm the setting.

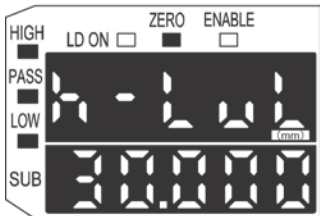

The trigger level is registered.

■ Setting Hysteresis Width

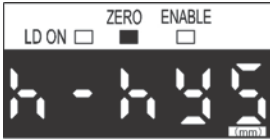

Use the LEFT or RIGHT key to display [H-HYS] on the main display.

Press the UP or DOWN key.

The leftmost digit of the sub-display will flash.

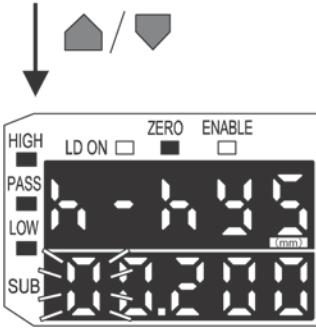

Set the desired trigger level.

Press the ENT key to confirm the setting.

The trigger level will be registered.

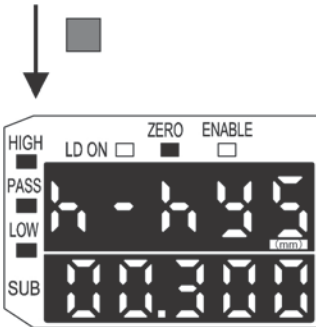
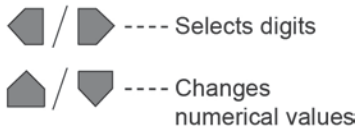

Peak hold + Self-up trigger

This holds the maximum value above the self trigger level.

The hold mode starts immediately after the power is turned on, or switching to the RUN or THR mode occurs, or immediately after the reset input has changed from ON to OFF. After the hold mode is started and up to the time that the 1st measurement is completed, the clamp value is output.

During the hold mode, sampling is performed of values above the self trigger level in the measurement values. At the point when the measurement values drop below the self trigger level, the maximum value obtained during the sampling interval is output.

After the 1st measurement is completed and up to the time that the 2nd measurement is completed, the results of the 1st measurement are held (Value A in the figure below) and output. Up until the 2nd measurement is completed, the results of the 2nd measurement (Value B in the figure below) are held and output. Thereafter, this process is repeated.

Please

When the self trigger level is set to UP or DOWN, the timing input has no influence on the sampling.

Example of self hold + Self-up trigger

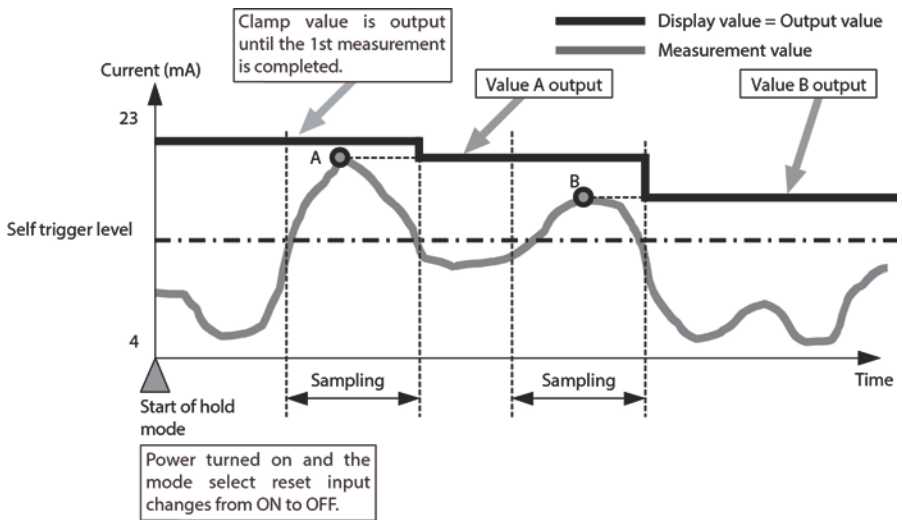

(Note) The above figure shows the case where the clamp value is set to the maximum current value, 23 mA. The clamp value can be arbitrarily set.
 Voltage value: -5 V to 5 V or approx. 5.5 V
 Current value: 3 to 21 mA or approx. 23 mA

■ Peak hold + Self-down trigger

This holds the minimum value below the self trigger level.

The hold mode starts immediately after the power is turned on, or switching to the RUN or THR mode occurs, or immediately after the reset input has changed from ON to OFF. After the hold mode is started and up to the time that the 1st measurement is completed, the clamp value is output.

During the hold mode, sampling is performed of values below the self trigger level in the measurement values. At the point when the measurement values drop rise above the self trigger level, the minimum value obtained during the sampling interval is output.

After the 1st measurement is completed and up to the time that the 2nd measurement is completed, the results of the 1st measurement are held (Value A in the figure below) and output. Up until the 2nd measurement is completed, the results of the 2nd measurement (Value B in the figure below) are held and output. Thereafter, this process is repeated.

Please

When the self trigger level is set to UP or DOWN, the timing input has no influence on the sampling.

Example of peak hold + Self-down trigger

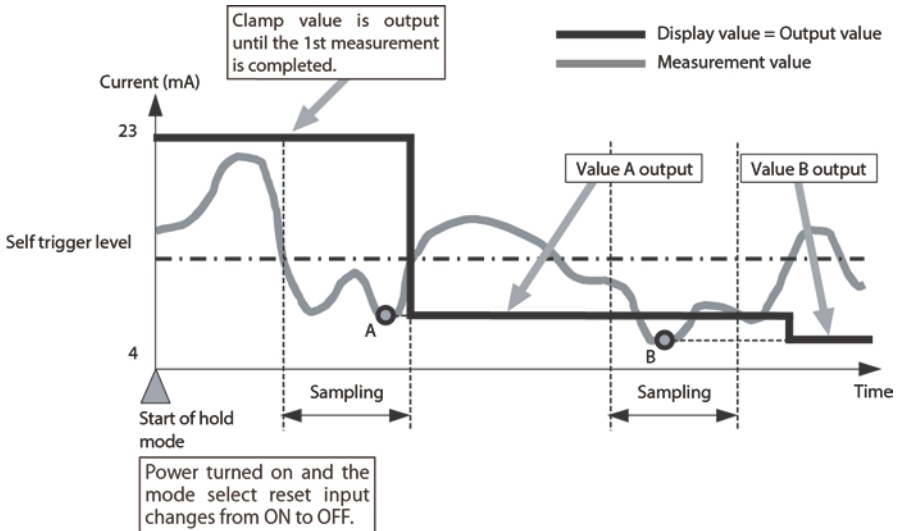

(Note) The above figure shows the case where the clamp value is set to the maximum current value, 23 mA. The clamp value can be arbitrarily set.

Voltage value: -5 V to 5 V or approx. 5.5 V

Current value: 3 to 21 mA or approx. 23 mA

■ Judgment outputs while the hold mode is in use

Judgment outputs while the hold mode is in use are based on the value after hold (= measurement value).

Therefore, while the hold mode is in use, the linear output, judgment output and display value do not change until the next measurement is completed and the value after hold is changed. Also, when the hold mode starts, and until the 1st measurement is completed, the following conditions are fixed.

Linear output: Clamp value is output.

Judgment output: All OFF

Main digital display: ' - - - - - '

Example of judgment output during hold (in case of peak hold)

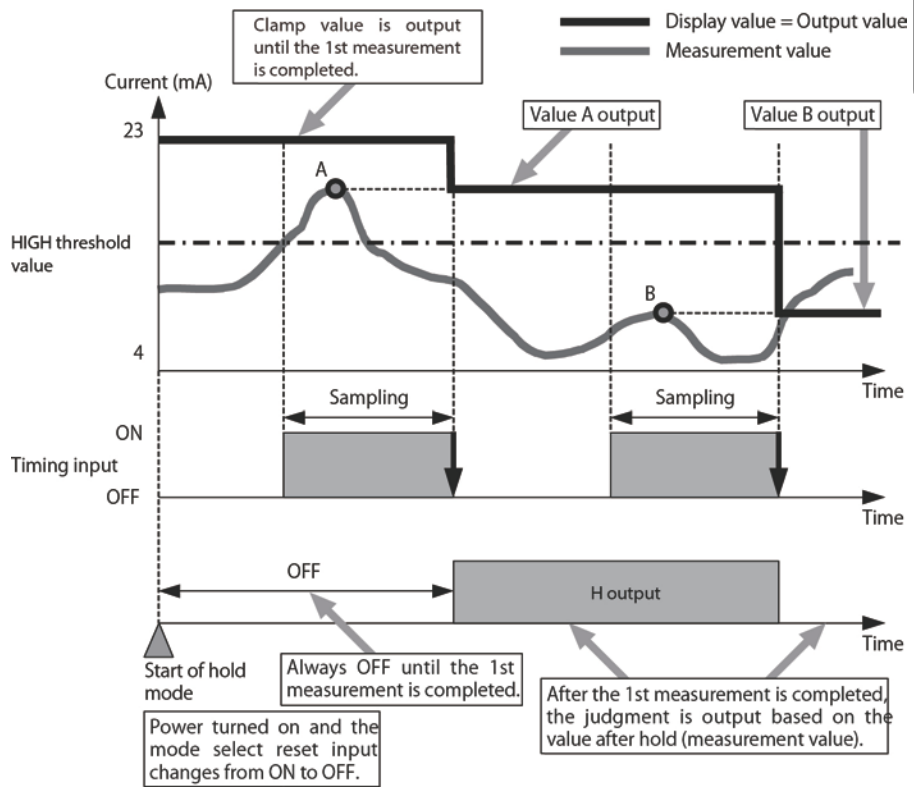

■ Setting Delay Time

This is useful for setting the time between timing input and the start of sampling.

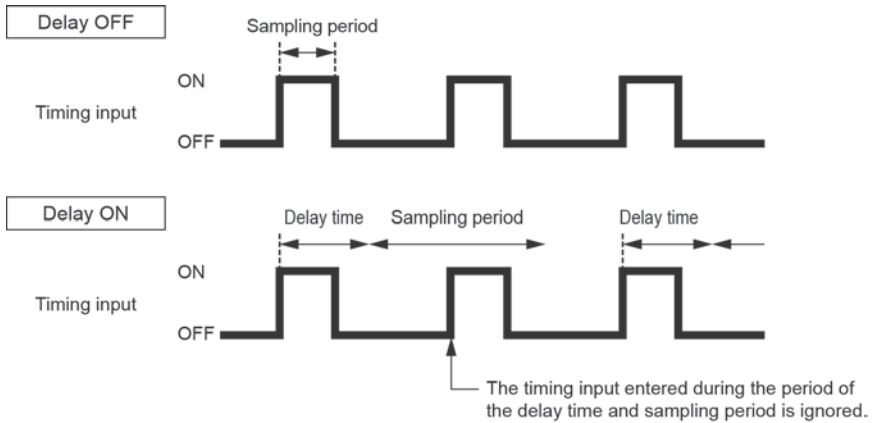

POINT

Make the sum of the delay time and sampling period less than the timing input ON interval. If the next timing input is received during the period of the sum of the delay time and sampling period, that timing input will be ignored.

The procedure for setting the delay time and the sampling time is shown below. [H-DLY] is not displayed if the hold conditions are set to OFF.

■ Selecting Delay

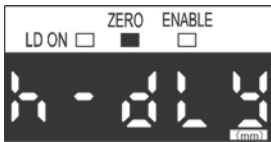

Use the LEFT or RIGHT key to display [H-DLY] on the main display.



Press the UP or DOWN key.

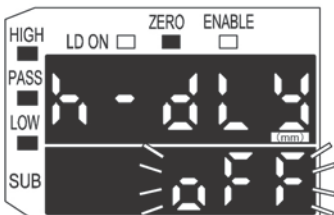

The sub-display will flash.

(Go to the next page)

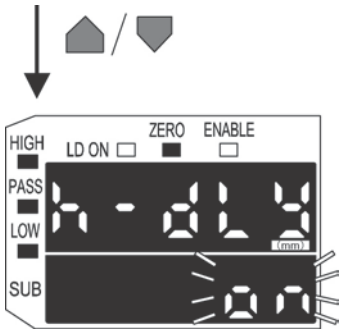

Press the UP or DOWN key to select ON.

Press the ENT key to confirm the setting.

■ Setting Delay Time / Sampling Period

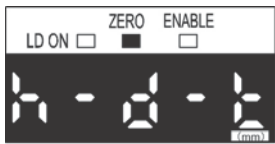

Use the LEFT or RIGHT key to display [H-D-T] on the main display.

Press the UP or DOWN key.

The leftmost digit of the sub-display will flash.

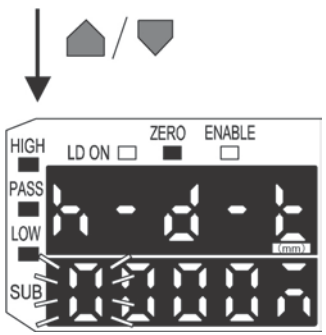

- / ---- Selects digits
- / ---- Changes numerical values

Set the desired delay time.

Press the ENT key to confirm the setting.

The delay time will be registered.

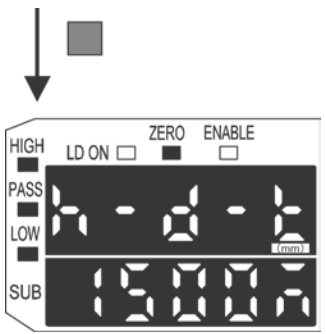

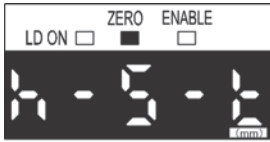

Use the LEFT or RIGHT key to display [H-S-T] on the main display.



Press the UP or DOWN key.

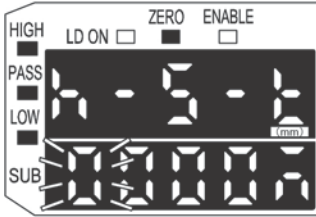

The leftmost digit of the sub-display will flash.

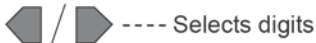

----- Selects digits



----- Changes numerical values

Set the desired sampling period. (Unit: ms)



Press the ENT key to confirm the setting.

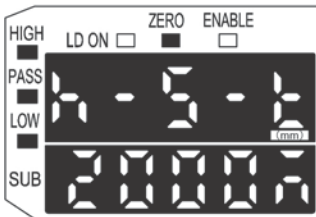

The sampling period will be registered.

3.8.6 Timer

■ Timer period

The timer period is equivalent to a delay time of the ON delay timer and the OFF delay timer and a pulse width of the ONE SHOT timer. Determine the timer period according to the PLC or other control system. The timer period can be set between 0 to 5,999 ms.

■ Without timer

The judgment output is output in accordance with the timing. The output response time is determined by the average sampling rate.

■ OFF delay timer

When the measurement value changes from PASS → HIGH or PASS → LOW, the only delay in the timing of the PASS output changing from ON to OFF is the timer period.

■ ON delay timer

When the measurement value changes from HIGH → PASS or LOW → PASS, the only delay in the timing of the PASS output changing from OFF to ON is the timer period.

■ ONE SHOT timer

When the measurement value changes from HIGH → PASS or LOW → PASS, a PASS output with a pulse width that is the length of the timer period only is output.

Furthermore, if PASS output pulses overlap each other, the later pulse has priority, so the original multiple pulses end up becoming only a single pulse.

Please

When the one shot timer is selected, the HIGH output and LOW output are not output, so exercise caution.

The time chart is shown in the following figure.

Type of timer and changes in the PASS Output (in case of timer period t_o)

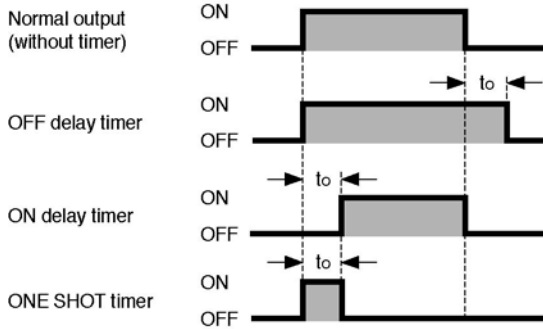

Timer processing is ordinarily involved in the PASS output.

Therefore, in case of the one shot timer, when HIGH \rightarrow PASS and LOW \rightarrow PASS, HIGH and LOW become OFF.

Also, as shown in the example in the figure below, if the measurement value changes from PASS to HIGH when the OFF delay timer period ' t_o ' is applied to the PASS output, the ON delay timer period ' t_o ' is applied to the HIGH output.

[Example]

OFF Delay timer (t_o), Measurement value changes from PASS \rightarrow HIGH

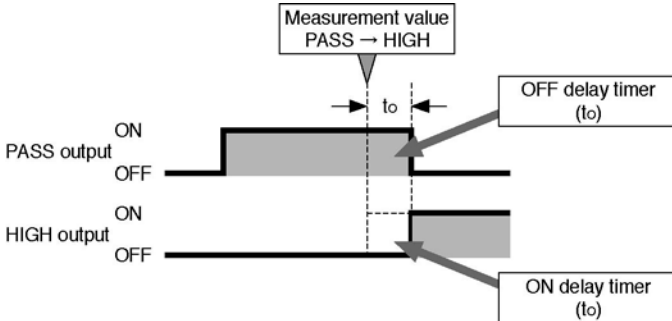

■ Setting method

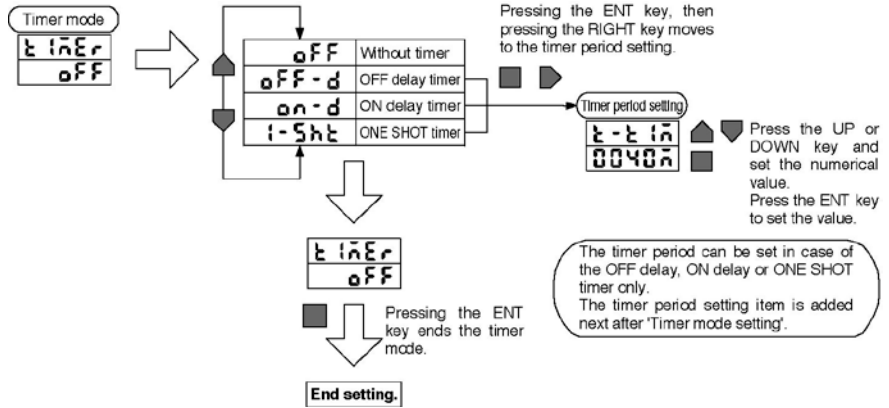

Timer period numerical value input method

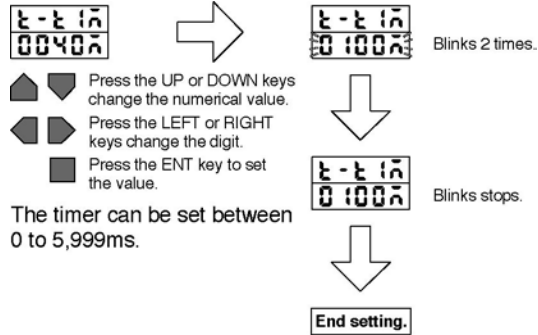

* Numerical values in the figure are setting examples.

3.8.7 Adjacent sensor calculation

In adjacent sensor calculation, mutual calculations are performed on the measurement values of 2 sensor heads, then a final output obtained. Three types of modes, A-B, A+B or THICK can be selected.



If adjacent sensor calculation is selected, the scaling set in each respective sensor head returns to the default values (the factory settings). If you desire to do scaling during adjacent sensor calculation, enable adjacent sensor calculation, then carry out scaling.

- If adjacent sensor calculation is performed, the span of the measurement value and the linear output value automatically becomes double, so exercise caution. An example where the 5mm width sensor head is used is shown in the following table.

Linear output	4 to 20mA
A-B	-5mm to +5mm
A+B	0mm to +10mm
THICK	-5mm to +5mm

Please

- If sensor heads with different detection widths are connected together, the correct width cannot be calculated, so exercise caution.
- When performing settings, set the 1CH controller on RUN, set the 2CH controller on FUN, then set it as a 2CH controller.

■ A - B

The difference between the measurement values of the 2 sensor heads is taken as the final output. The data from the 1CH controller becomes B and the data from the 2CH controller becomes A.

■ A + B

The sum of the measurement values of the 2 sensor heads is taken as the final output. The data from the 1CH controller becomes B and the data from the 2CH controller becomes A.

■ THICK

The thickness of a sensing object clamped between two Sensor Heads is used as the final output.

■ Calculation results output

The result of the calculations is displayed in the 2CH controller and output. The B data are displayed in the 1CH controller and output.

In the case that 2 controllers are linked together and they are set in the ordinary display direction, the controller on top becomes 1CH and the controller on the bottom becomes 2CH.

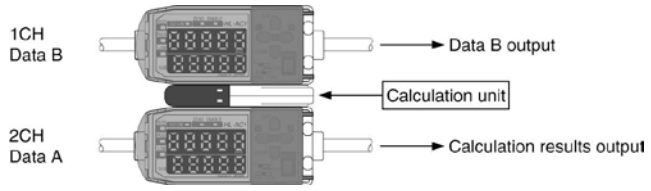

■ Setting method

Set the Mode Select switch on the 1CH controller in the RUN position.

Set the 2CH controller on FUN, the carry out setting with the 2CH controller.

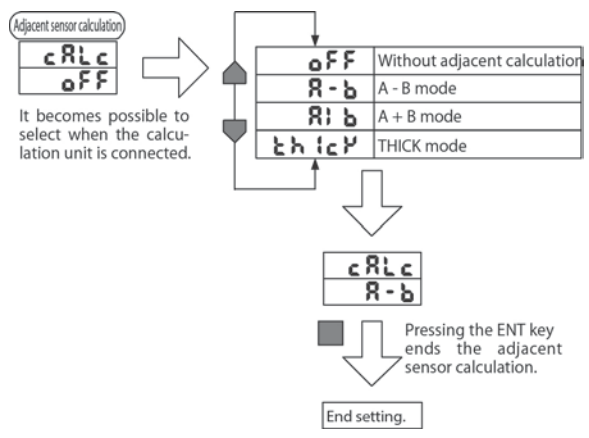

* Display items in the figure are setting examples.



If the Mode Select switch of the 1CH controller is set on FUN, it results in an error. Set the 1CH controller's Mode Select switch in the RUN position.

3.8.8 Adjacent calculation THICK (Thickness measurement)

This is useful to measure the thickness of an object clamped between the sensor heads. Prepare a sensing object of known thickness beforehand as a standard sensing object. If the thickness data is input with the standard sensing object placed in positions, the scaling information will be registered. When the mode is changed to RUN after the setting, the thickness will be measured based on the scaling information.

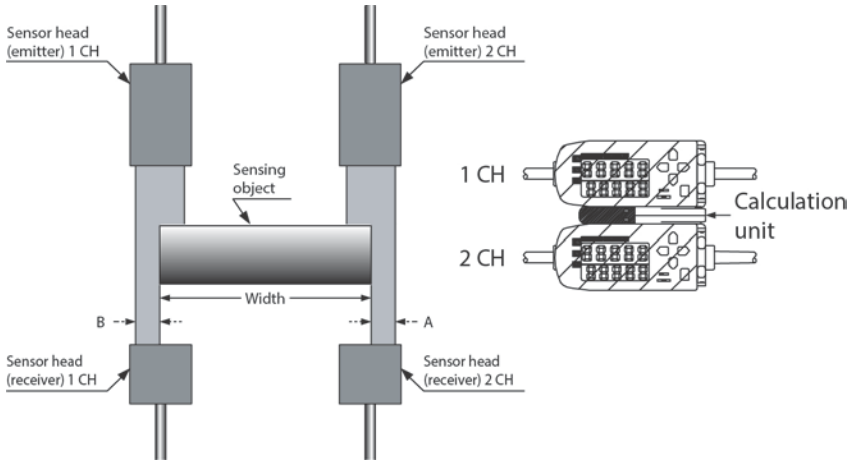

Thickness measurement (THICK mode)

Please the standard sensing object in positions, and perform the following operation.

■ Switching to FUN mode/CALC



Set the mode switch to FUN on the CH2 Amplifier Unit.



Use the LEFT or RIGHT key to display [CALC] on the main display.

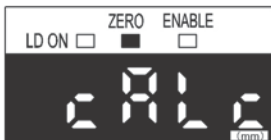

■ Selecting THICK Mode

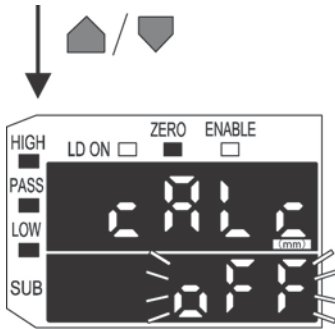

Press the UP or DOWN key.

The sub-display will flash.

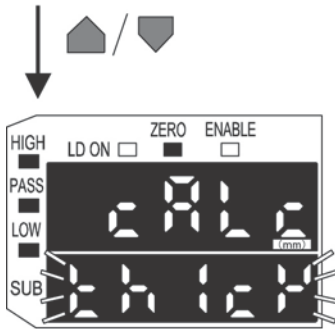

Use the UP and DOWN keys to display [THICK] on the sub-display.

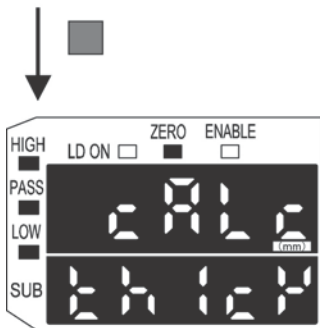

Press the ENT key to confirm the setting.

■ Setting Thickness Data

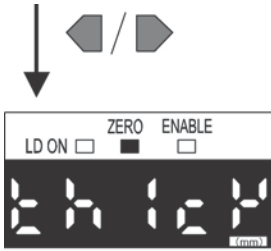

Use the LEFT or RIGHT key to display [THICK] on the main display.

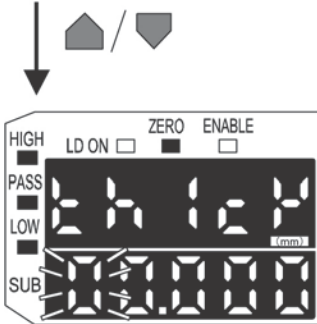

Press the UP or DOWN key.

The leftmost digit of the sub-display will flash.

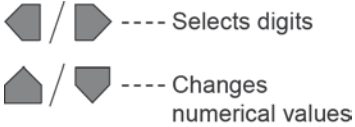

Set the thickness of the standard sensing object as an integer value.

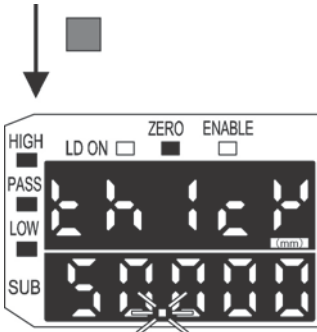

Press the ENT key to confirm the setting.

The numeric values will be confirmed and the decimal point will flash.

(Go to the next page)

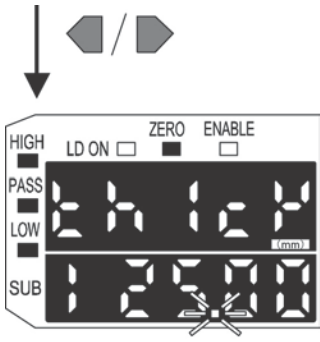

use the LEFT and RIGHT keys to move the decimal point.

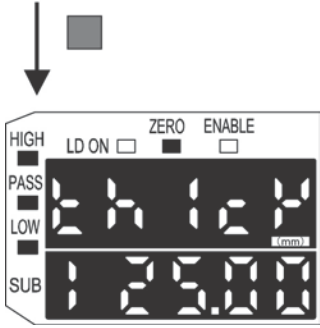

Press the ENT key to confirm the setting.

The scaling values (A and B) will be registered for both Amplifier Units.



If the following display appears, the standard sensing object may be outside the measurement range. Adjust the position until the ENABLE indicator is lit on the controllers and perform the thickness setting again.



3.8.9 Setting initialization

All the setting conditions can be initialized.

Special settings such as the standard laser beam reception intensity setting, the auto scaling setting, monitor focus function and scaling function values can be initialized.

Please

If initialization is performed, you cannot return to your original settings. You will have to reset all the settings again, so exercise caution.

● Default values

These values are set at the factory before shipping.

If the settings are initialized, they are changed to these values.

A list of default settings is shown below.

Function	Default value
Scaling	OFF
Average times	32 times
Hysteresis width setting	0.5% of full scale (F.S.)
Hold	OFF (disabled)
Timer	OFF (disabled)
Adjacent sensor calculation (only when 2 units are connected)	OFF (disabled)
Special select	CLOSE
Monitor focus function	4V (20mA): Maximum value -4V (4mA): Minimum value
Linear output correction	OFF (disabled)
Differential function	OFF (disabled)
Display reverse function	OFF (disabled)
ECO display function	OFF (disabled)
Display digit limit	All digits displayed
Settings when not measuring	KEEP
Zero reset memory	OFF
Gain select	METAL
Auto scale value	100-L
HIGH threshold value	Display maximum value
LOW threshold value	Display minimum value
Sub-digital display function	Threshold value
Standard laser beam reception volume setting	OFF (not set)
Zero reset function	OFF (disabled)

■ Setting initialization method

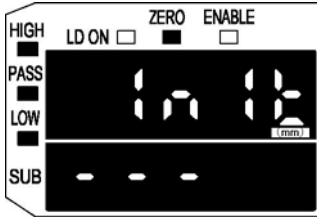

Press the ENT key for 3 sec.

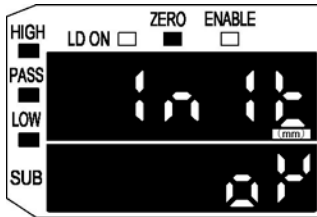

Setting is ended.

Set the mode select switch in the FUN position, and select '10.0' in the main digital display.



RUN THR FUN

Press the ENT key for 3 sec. or more.

'10.0' is displayed in the main digital display.

3 sec. '----' is displayed in the sub-digital display.

After 3 sec., '0.0' is displayed in the sub-digital display and initialization is completed.

3.8.10 Monitor focus function

With this function, the linear output range and inclination, etc. with respect to the display value can be specified. Setting is done by determining the 2 output values with respect to the desired display value.



If the width between the 2 specified points is 10% of the full scale (F.S.), the setting becomes NG. Also carry out the monitor focus setting after scaling.

It is recommended that the linear output value with respect to the display value be determined after setting the display value with respect to the actual distance by scaling.

■ Setting method

First, select 'SEt' or 'ALL' in the special settings.

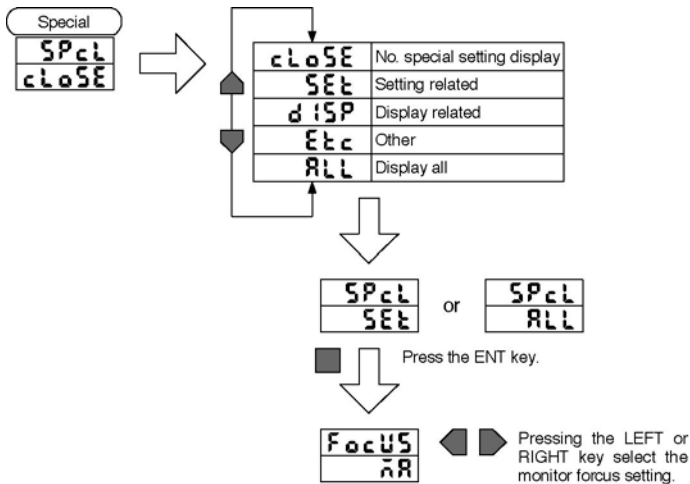

The procedure for setting of monitor focus is shown in the following chart.

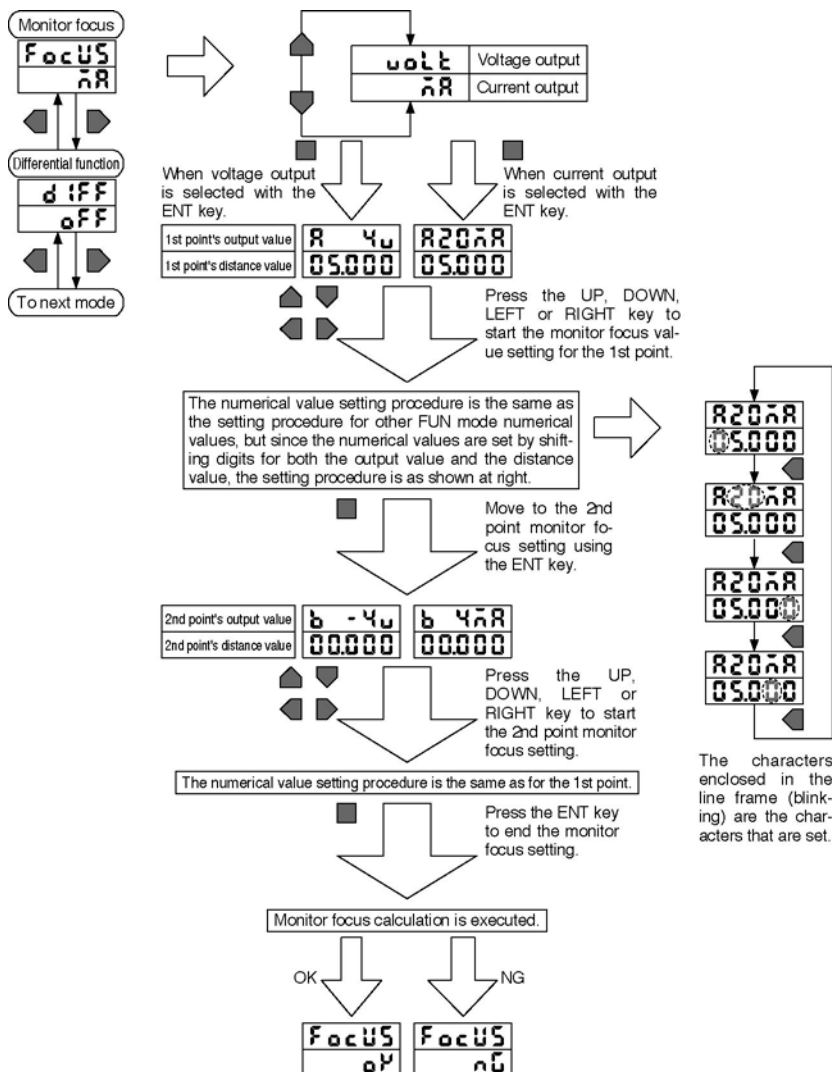

* The items displayed in the chart are setting examples.

Monitor focus example 1

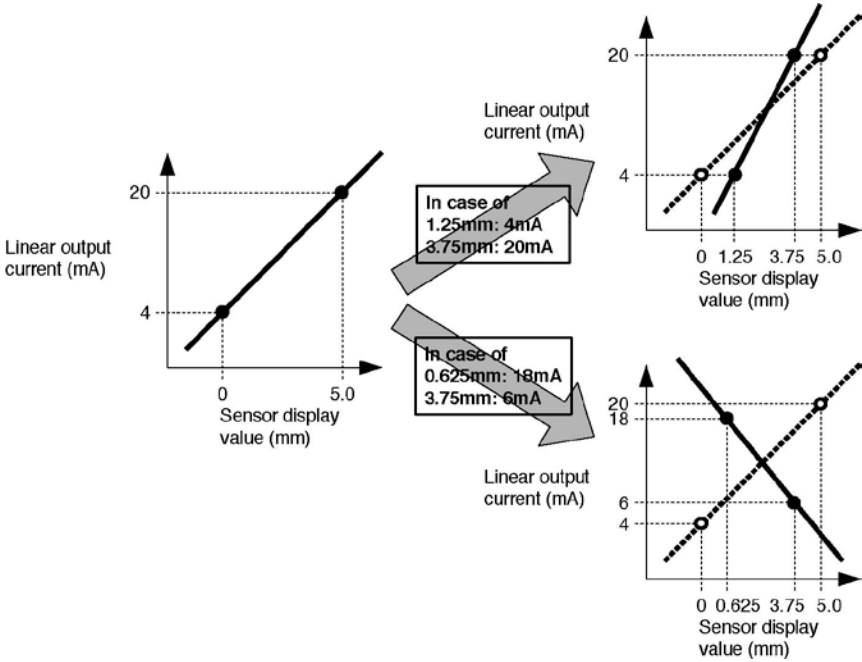

Monitor focus example 2

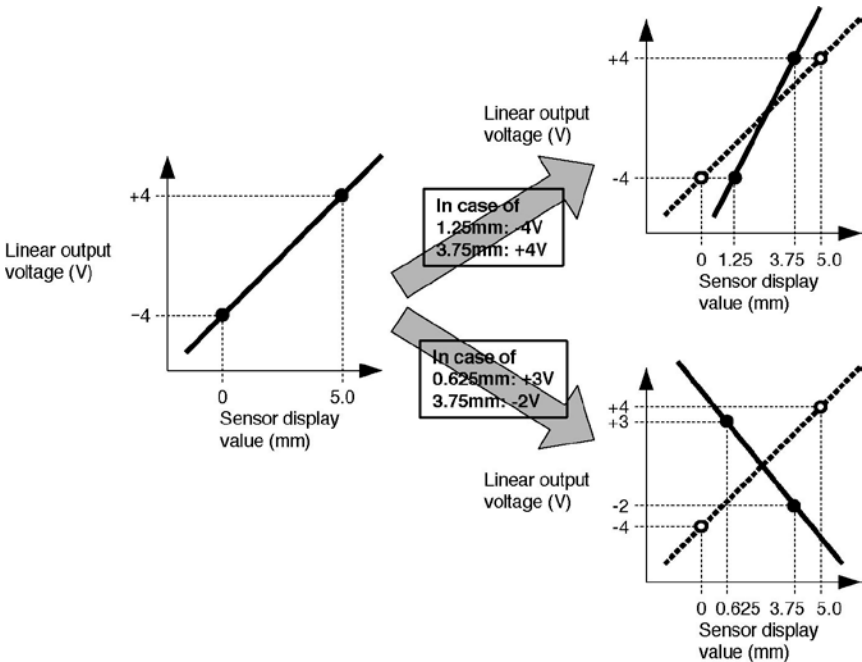

Monitor focus example 3 (In case of differential enabled)

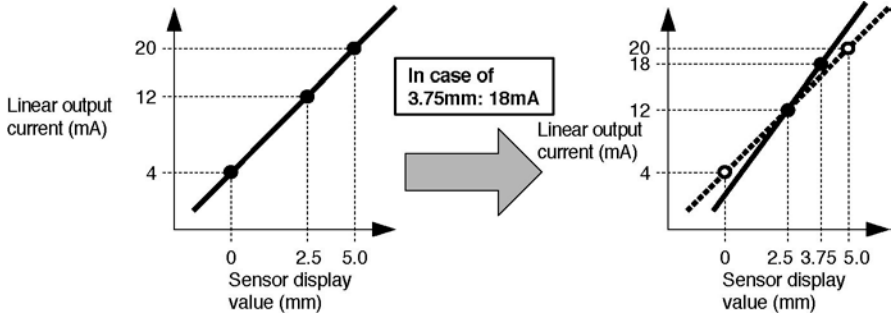

Reference» See '3.8.12 Differential function' concerning the differential function.

Please

Zero reset is automatically cleared when monitor focus is set, so exercise caution.

3.8.11 Linear output correction

The linear output correction function is useful to correct the linear output values of the controller (current or voltage) to the standard values measured by an external device (ammeter or voltmeter).

In the following section, a current output is used as an example. Arbitrary current values are set for any two points, A and B. The current measurement value is input as A, and the value after the correction is input as A'. By setting the values of B and B' as well, the values can be corrected as shown in the figure below.

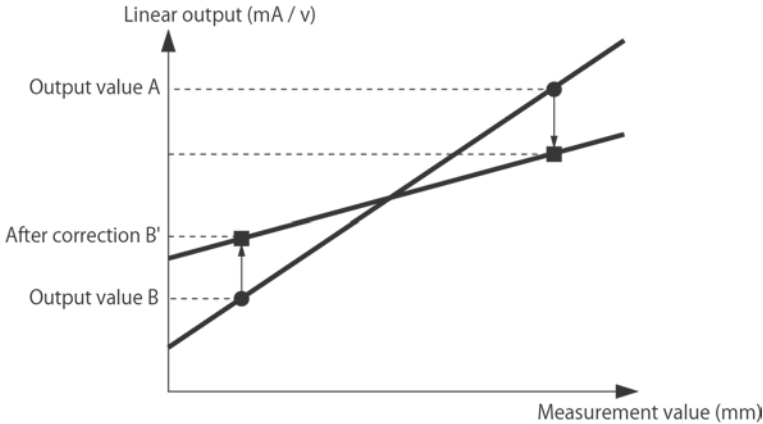

- The correction value can be set within the range -999 to +999. 0.35 μ A for the current value and 0.175 mV for the voltage value are corrected per correction value 1.
- The linear output correction is unset by default.

Connect the linear output line to the external device (ammeter) that becomes the reference of the output current or voltage, and perform the following operation. In the following section, a current output is used as an example.

■ Switching to FUN mode/SPCL



Turn ON the power supply and move the mode switch to FUN.



Use the LEFT or RIGHT key to display [SPCL] on the main display.

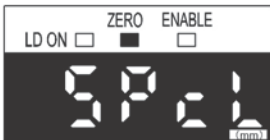

■ Switching to L-ADJ

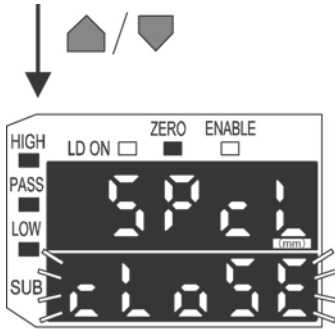

Press the UP or DOWN key.

The sub-display will flash.

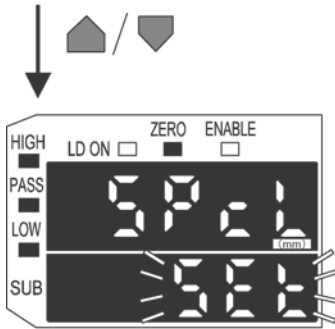

Use the UP and DOWN keys to display [SET] or [ALL].

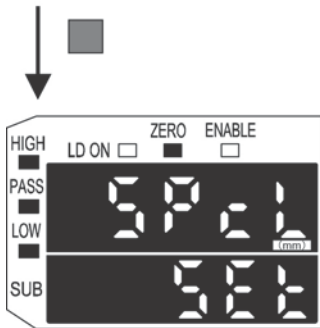

Press the ENT key.

(Go to the next page)

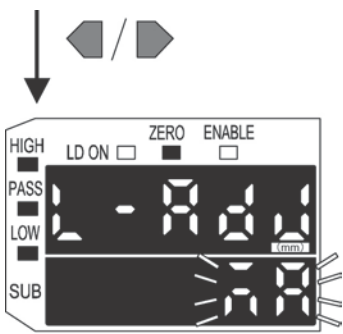

Use the LEFT or RIGHT key to display [L-ADJ] on the main display.

The unit for the monitor focus settings (mA or V) will be displayed with flashing.

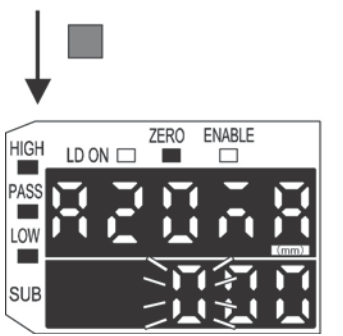

Press the ENT key.

The display will change to the settings for the first point (A). The output current will be displayed on the main display. The correction value will be displayed on the sub-display and the leftmost digit will flash.

■ Setting Correction Value

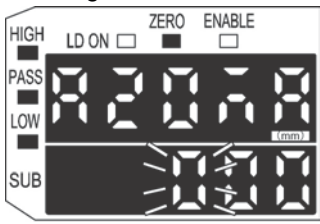

Set the output current and correction values for the first point (A).

Adjust the correction value on the sub-display so that the ammeter reading and the output current shown on the main display are the same.

The larger the correction value, the larger the output current. The correction value can be set within the range -999 to 999.

To set a negative value, make the leftmost digit of the sub-display flash and change the value.

Press the ENT key to confirm the setting.

The correction value for the first point will be confirmed. The screen for setting the second point will be displayed.

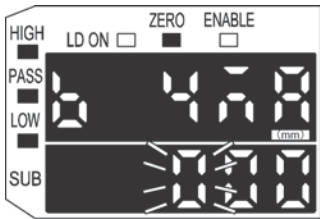

Use the same procedure as the first point to set the correction value for the second point.



Press the ENT key.

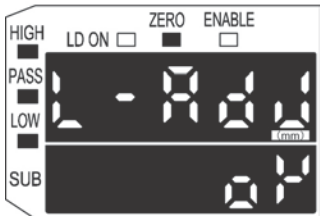

If the linear output correction has been registered correctly, the sub-display will show [OK].

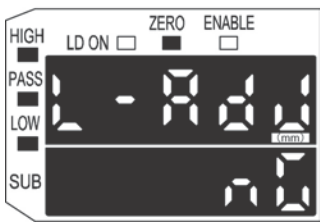





If not, the display will show [NG]. Check that the current (voltage) value for the tow points are not the same and execute again.



Use the LEFT and RIGHT keys to select digits and use the UP and DOWN keys to change values.

Use the keys as below to move between the main display and sub-display.

-  /  ---- Selects digits
-  /  ---- Changes numerical values

3.8.12 Differential function

This function makes the amount of change in the measurement value an output value.

Use this function when measuring if you are paying attention to changes in measurement values, as when counting the number of work pieces, etc.

If the differential mode is selected, the number of comparison cycles (laser beam emission periods) can be set.

Example of measuring values and differential values at those times.

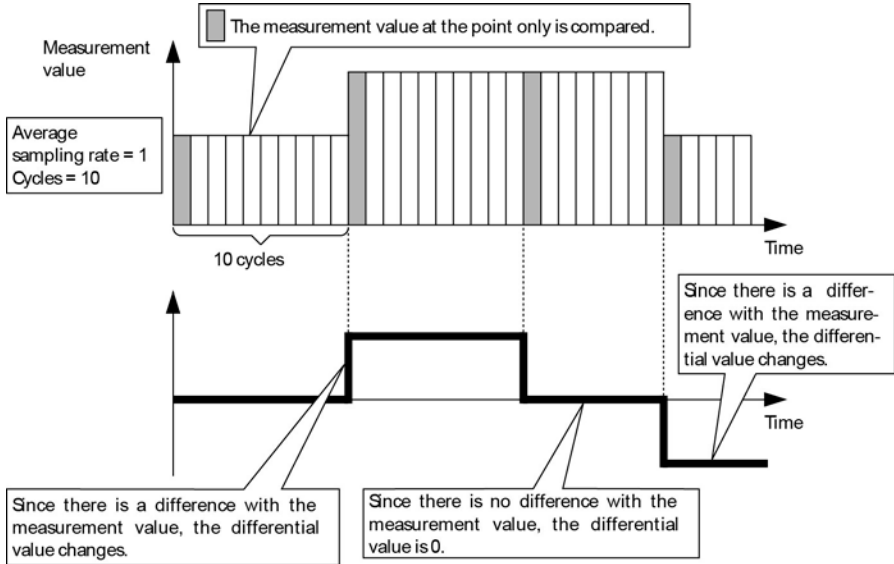

The amount of change in the measurement value is the difference between the value in this measurement and that in the previous measurement.

If the average sampling rate is increased, the change volume becomes smaller, so exercise caution.

■ Setting method

First, select 'SEt' or 'ALL' in the special settings.

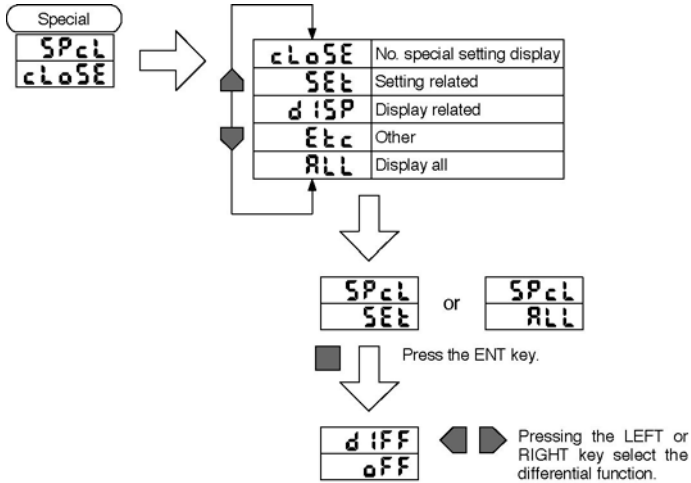

Next, set the differential function.

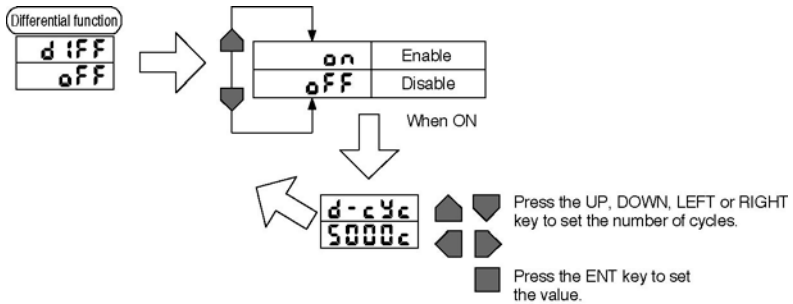

Number of cycles input method

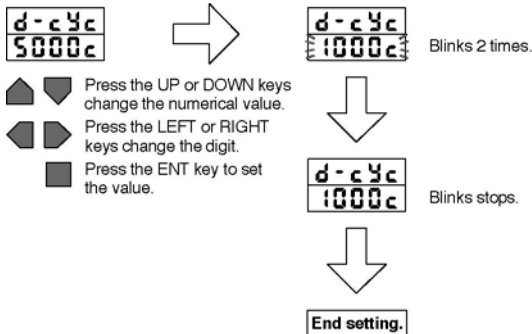

* Numerical values in the figure are setting examples.

3.8.13 Previous value comparison

This function is used to only detect sudden changes. The hold function must be set because the previous hold value is used for comparison.

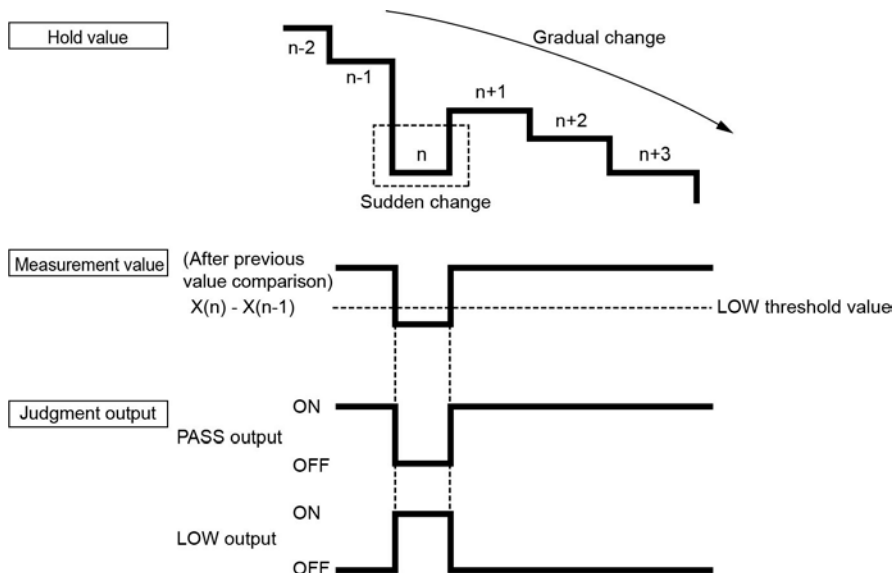

- The hysteresis width setting will be disabled if this function is used.
- If the judgement for the previous measurement is HIGH or LOW, the comparison is performed with the hold value before that.

(Note): The hysteresis width setting will be disabled if this function is enabled,

■ Switching to FUN mode/SPCL



Turn ON the power supply and move the mode switch to FUN.



Use the LEFT or RIGHT key to display [SPCL] on the main display.

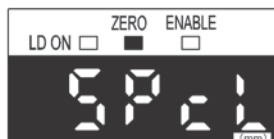

■ Switching to COMP

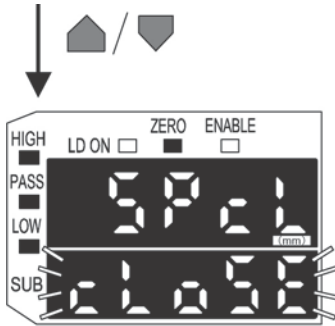

Press the UP or DOWN key.

The sub-display will flash.

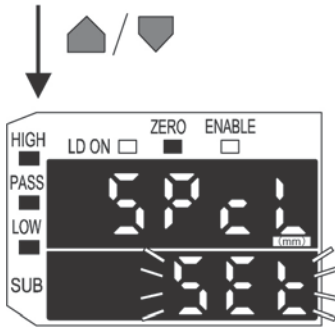

Use the UP and DOWN keys to display [SET] or [ALL].

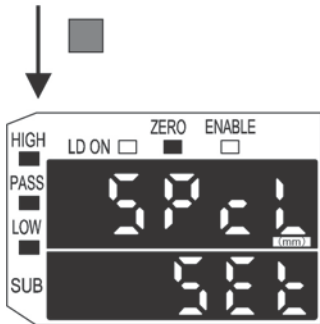

Press the ENT key.

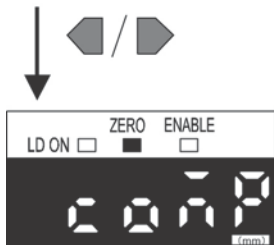

Use the LEFT or RIGHT key to display [COMP] on the main display.

■ Setting Previous Value Comparison Function



Press the UP or DOWN key.

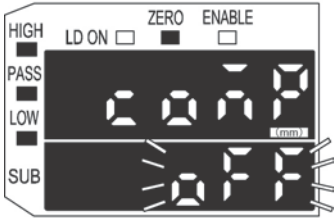

The sub-display will flash.

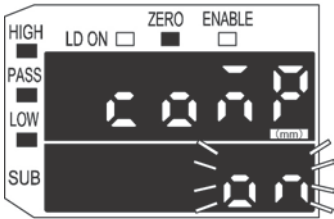

Use the DOWN keys to display [ON].



To set, press ENT key.

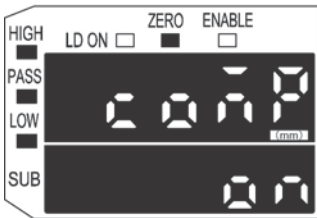

"Previous Value Comparison Function" will be available.

3.8.14 Display reverse function

The digital display's display direction can be selected.

Select the forward direction or the reverse direction to match the direction of installation on the equipment.

The display direction is the up / down reverse direction.

When the display direction is reversed, the operation keys UP and DOWN, RIGHT and LEFT are replaced with each other.

■ Setting method

First, select ' dISP ' or ' ALL ' in the special settings menu.

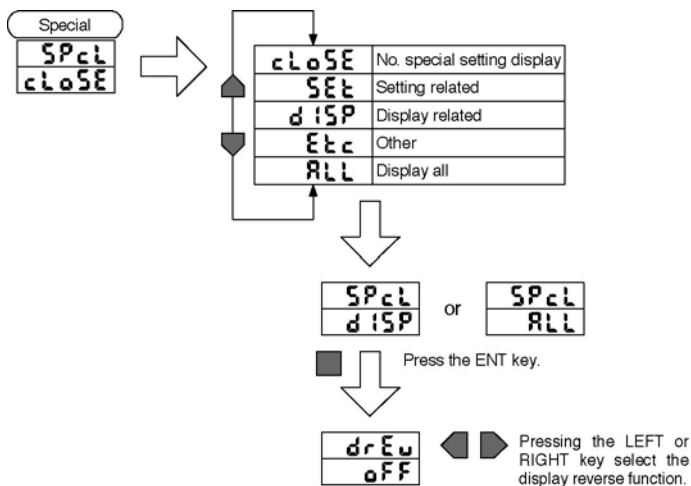

Next, set the display reverse ON or OFF.

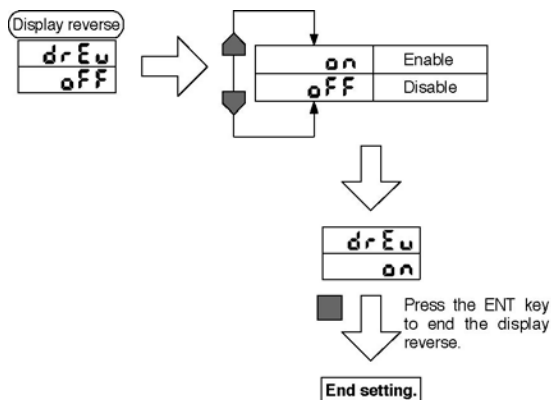

* The display in the figure is a setting example.

3.8.15 ECO display function

This selects whether the ECO display function will be enabled or disabled.

When the ECO display function is enabled, the digital display is in the dark lighting state.

■ Setting method

First, select 'dISP' or 'ALL' in the special settings menu.

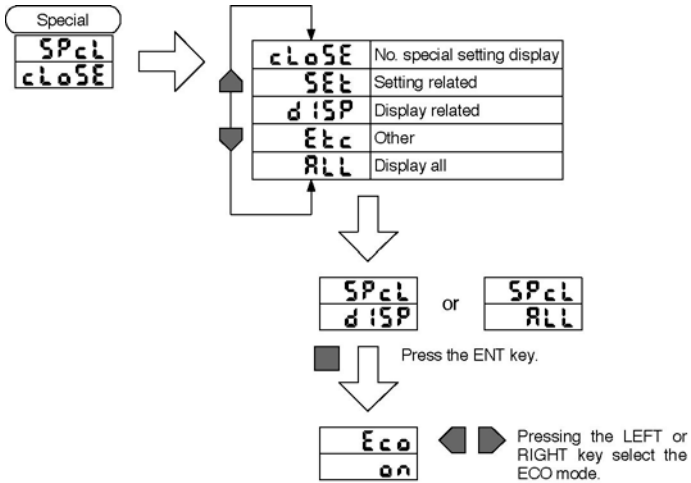

Next, set the ECO mode ON or OFF.

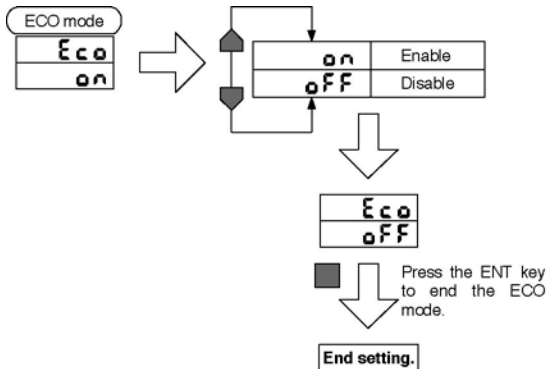

* The display in the figure is a setting example.

3.8.16 Display digits limitation

This determines the number of display digits in the main-digital and sub-digital displays. If the number of digits is limited, the digits are turned off beginning with the lowest order digit.

Also, all the digital display is turned off when 0 digit is selected.

However, the above contents are applicable only in the RUN mode.

■ Setting method

First, select 'dISP' or 'ALL' in the special settings menu.

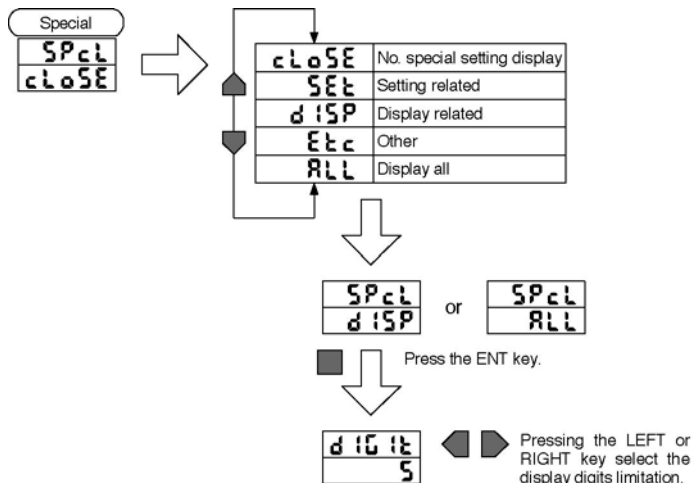

Next, set the number of display digits.

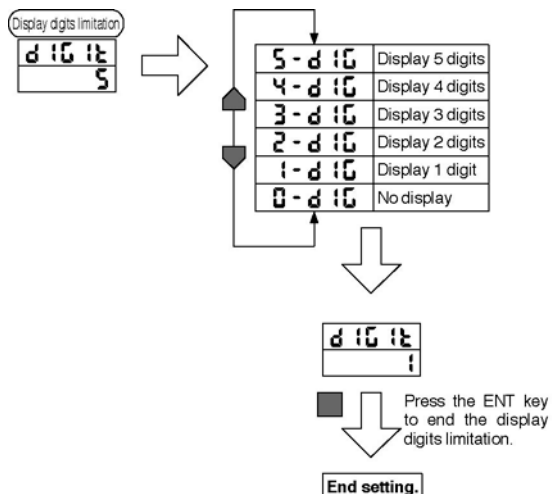

* The display in the figure is a setting example.

3.8.17 Non-measuring time setting

This sets the output method during non-measuring time (during reset input, when the laser beam intensity is abnormal).

	Non-measuring time setting	
	CLAMP	KEEP
Judgment Output	All OFF	Keep the value from just before the non-measuring state.
Linear Output	Clamp value	

(Note) The clamp value can be set.

Voltage value: -5 V to 5 V or approx. 5.5 V

Current value: 3 to 21mA or approx. 23mA

■ Setting method

First, select ' Etc ' or ' ALL ' in the special settings menu.

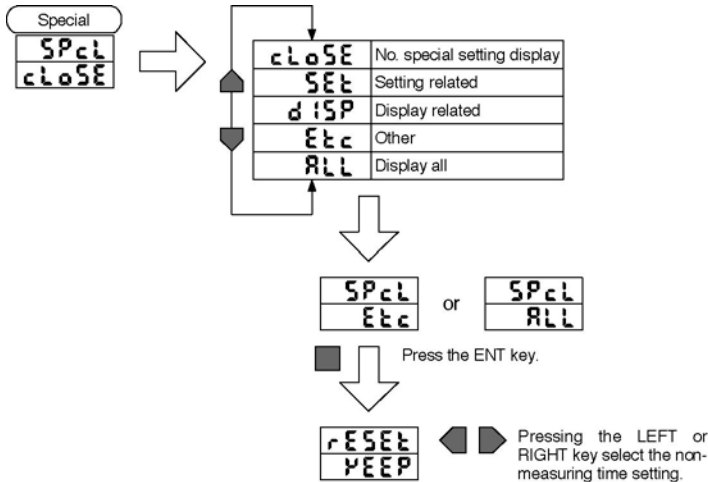

Next, set the non-measuring time setting on ' YEEP ' or ' cLRAP '.

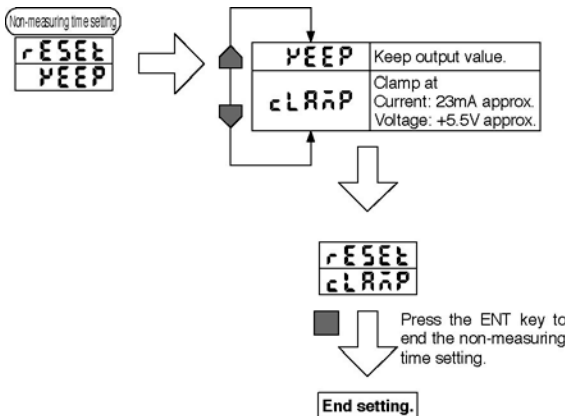

* The display in the figure is a setting example.

When CLAMP is selected, set the clamp value.

■ Setting Clamp Value (Only when selecting CLAMP)

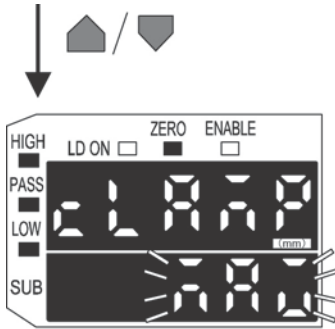

Press the UP or DOWN key.

The sub-display will flash.

The characters "MAX" is displayed. To set the max value, press the ENT key.

To set the clamp value as current value or voltage value, press DOWN key.

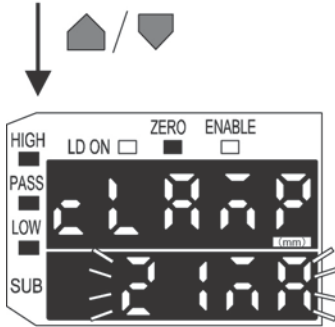

Select the desired clamp value.

Press the ENT key to confirm the setting.

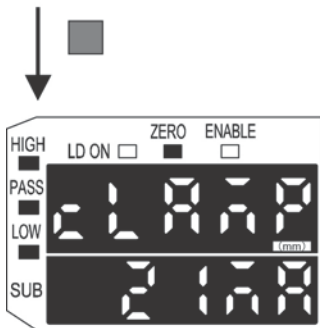

The input value will be registered.

3.8.18 Zero reset memory function

This selects whether or not to save the zero reset level in memory when the power is turned OFF.

If you desire to reproduce the zero reset level from the previous operating session when you turn the power ON again, then enable this function. If this function is enabled, the zero reset level data are written to EEPROM each time. The writing life of the EEPROM is only about 100,000 times, so if zero reset is used for each measurement, disable this function in order to protect the memory. However, even if the zero reset memory function is disabled, the zero reset level is written in EEPROM in the following cases.

- When setting the threshold values.
- When performing each of the settings in the FUN mode.

■ Setting method

First, select 'Etc' or 'ALL' in the special settings menu.

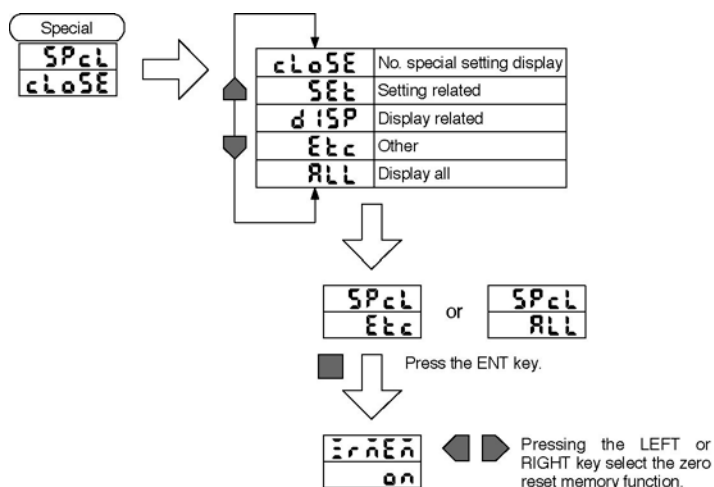

Next, set the zero reset memory function ON or OFF.

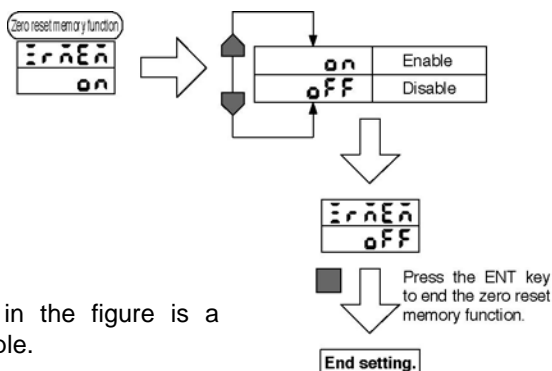

* The display in the figure is a setting example.

3.8.19 Gain switching

The Light-receiving sensitivity can be changed according to the condition of the sensing object. The size of the gain is as follows. Normally, use the METAL setting. Although the MIROR mode can be set, it is ineffective.

(Large) BLACK / WHITE / METAL / MIROR (Small)

Please

If the appropriate gain value is not set in accordance with the measuring environment, the output could be saturated and rapidly reach a state where measurement was impossible, so exercise caution.

■ Setting method

First, select 'Etc' or 'ALL' in the special settings menu.

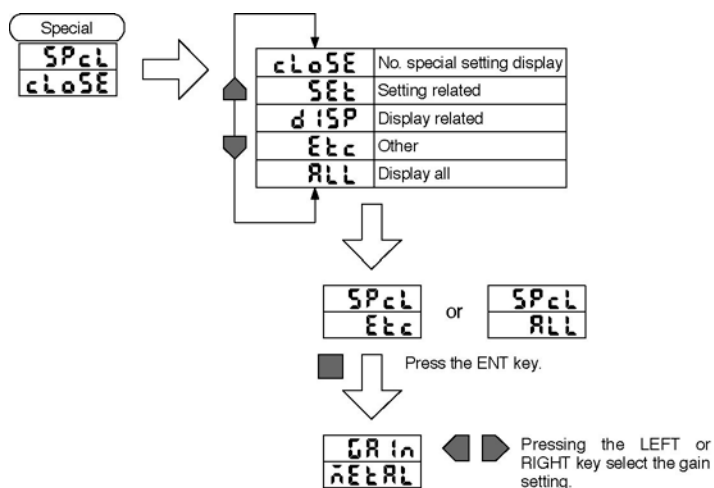

Next, select the gain setting and set it.

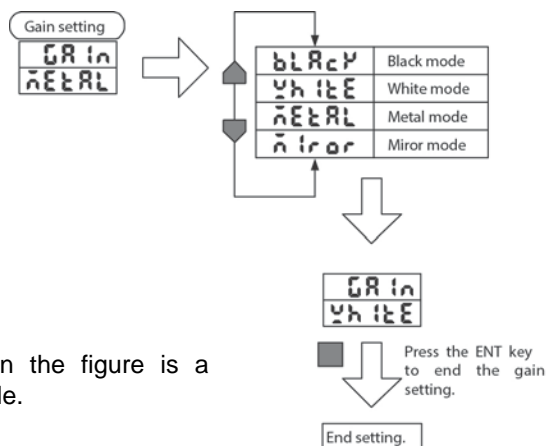

* The display in the figure is a setting example.

3.8.20 Key lock function

The controller's key input can be disabled.

Once the key input is disabled, the controller will not accept any key inputs until the key lock is released. Use this function to avoid changing the setting by mistake.

■ Key lock setting method

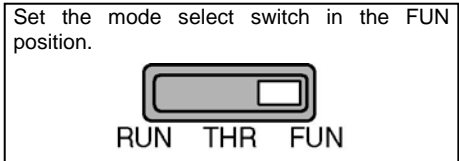
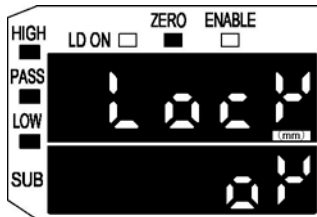
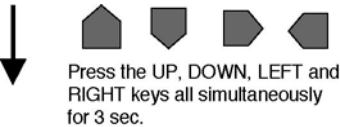
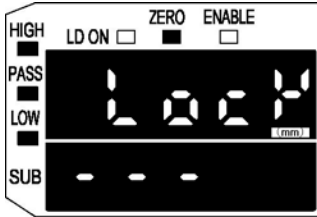

Press the UP, DOWN, RIGHT and LEFT keys all simultaneously for 3 seconds or more. 'Lock' is displayed in the main-digital display. '----' is displayed for 3 seconds in the sub-digital display.

After 3 sec., 'OL' is displayed in the sub-digital display and the key lock setting is completed.

■ Key lock release method

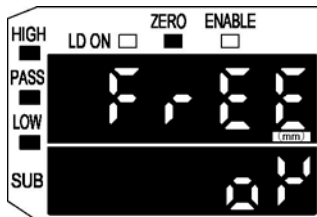

Press the UP, DOWN, RIGHT and LEFT keys all simultaneously for 3 seconds or more. 'Free' is displayed in the main-digital display. '----' is displayed for 3 seconds in the sub-digital display.

After 3 sec., 'OL' is displayed in the sub-digital display and key lock is released.

However, operation of the following keys is enabled.

- Mode select switch operation
- Threshold select switch operation
- Key lock release operation

CHAPTER 4





ERRORS: WHEN THIS HAPPENS...

This chapter explains concerning the display when each type of error occurs and the treatment, etc.

4.1	Error: When This Happens.....	162
4.1.1	Error display during normal measurement	162
4.1.2	Error display when setting numerical values.....	163
4.1.3	Error display during adjacent sensor calculation	163
4.1.4	Scaling cannot be set	164
4.1.5	Monitor focus cannot be set.....	164
4.1.6	Threshold values cannot be set.....	164
4.1.7	Hysteresis cannot be set	164
4.1.8	Laser deterioration.....	164

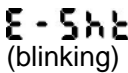
4.1 Error: When This Happens...

4.1.1 Error display during normal measurement

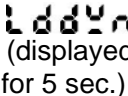
Display	Cause and countermeasure	Recovery method
 (blinking)	One or all the judgment outputs is in the short circuit state. ⇒ Remove the load short circuit state.	Auto recovery
 (blinking)	The EEPROM is destroyed or data are abnormal. ⇒ Press the ENT key 3 sec. or more. ⇒ If there is no improvement, replace the controller.	Turn the power on again or replace the controller.
 (blinking)	The cable connecting the sensor heads and controller is not connected (Note 1) or the sensor heads are abnormal. ⇒ Connect the sensor heads. ⇒ If there is no improvement, replace the sensor heads.	Auto recovery or replace the sensor heads.
 (blinking)	The light reception intensity is insufficient. See '4.1.8 Laser deterioration'. ⇒ If the gain setting has been changed, set the optimum gain setting. ⇒ If there is no improvement, change to an appropriate work piece.	Auto recovery
 (blinking)	The light reception intensity is saturated. See '4.1.8 Laser deterioration'. ⇒ If the gain setting has been changed, set the optimum gain setting. ⇒ If there is no improvement, change to an appropriate work piece.	Auto recovery
 (displayed for 5 sec.)	The sensor head's laser is deteriorated. See '4.1.8 Laser deterioration'.	Replace the sensor head.

- Notes:
- 1) No error is displayed if the sensor head to controller connection cable is connected to the controller and not connected to the sensor head.
 - 2) Threshold value direct input is possible even when the light reception intensity is saturated. However, teaching is impossible.
 - 3) If multiple abnormal states occur simultaneously, the display priority order is from the top of the above table.

4.1.2 Error display when setting numerical values

Display	Cause and countermeasure	Recovery method
ErrLh (blinking)	This is output when setting of a LOW threshold value that is greater than the HIGH threshold value is attempted. ⇒ See '4.1.6 Threshold values cannot be set', then reset the threshold values.	Auto recovery
ErrhL (blinking)	This is output when setting of a HIGH threshold value that is lower than the LOW threshold value is attempted. ⇒ See '4.1.6 Threshold values cannot be set', then reset the threshold values.	Auto recovery
Errou (blinking)	The set numerical value is too large. (See '4.1.4 Scaling cannot be set' to '4.1.7 Hysteresis cannot be set') ⇒ Input the appropriate numerical values.	Auto recovery
Errud (blinking)	The set numerical value is too small. (See '4.1.4 Scaling cannot be set' to '4.1.7 Hysteresis cannot be set') ⇒ Input the appropriate numerical values.	Auto recovery

4.1.3 Error display during adjacent sensor calculation

Display	Cause and countermeasure	Recovery method
E-dAL (blinking)	The adjacent calculation communications data are abnormal. ⇒ Set the 1CH side controller in the THR mode or the RUN mode. ⇒ Check if the light reception intensity of the 1CH side controller is not abnormal. ⇒ Check if the connections between the controllers are normal. ⇒ If there is no improvement, replace the controller or the calculation unit.	Auto recovery or replace the controller or calculation unit.
E-chL (blinking)	Single unit operation was attempted with A - B, A + B, or thickness measurement still selected. ⇒ Connect the 2 units again, turn adjacent calculation off, then try single unit operation. ⇒ If the above operation is difficult, carry out setting initialization processing.	Auto recovery
E-thY (blinking)	Values of the THICK (thickness measurement) mode are abnormal. ⇒ Set the thickness data.	

4.1.4 Scaling cannot be set

In the following cases, the scaling setting becomes NG.

- If the width between the points in 2-point scaling is less than 10% of the full scale (F.S.).
- If the value input for scaling is extremely small, or extremely large.

4.1.5 Monitor focus cannot be set

The setting becomes NG if the width between the two specified points is 10% of the full scale (F.S.).

Also be sure to set monitor focus after completing the scaling setting. It is recommended that the linear output value be decided after fixing the display value with respect to the actual distance in scaling.

4.1.6 Threshold values cannot be set

Always set the threshold values so that the 'HIGH threshold value' > 'LOW threshold value'.

Also, if the hysteresis (Hys) is too great, and it happens that the

(HIGH threshold value - LOW threshold value) < Hys,

it will be impossible to obtain a PASS judgment, and the setting will be done. Also, in cases where the threshold value is outside the measuring range of the sensor, the value cannot be set.

4.1.7 Hysteresis cannot be set

If the hysteresis (Hys) is too great, and it happens that the

(HIGH threshold value - LOW threshold value) < Hys,

it will be impossible to obtain a PASS judgment, and the setting will be done. Set the hysteresis setting value so that it is low so that the above conditions do not occur.

4.1.8 Laser deterioration

The message 'Laser' is displayed for 5 sec. in the main digital display when the power is turned on. In this case, the laser in the sensor head has deteriorated. Replace the sensor head.

CHAPTER 5

SPECIFICATIONS AND DIMENSIONS

This chapter explains concerning ratings and performance.

5.1	Ratings / Performance	166
5.1.1	Sensor head	166
5.1.2	Sensor head (FDA Compatible).....	167
5.1.3	Controller	168
5.1.4	Calculation unit.....	170
5.2	Dimensions	171
5.2.1	Sensor head	171
■	HL-T1001A [ϕ 1mm type]	171
■	HL-T1001F [ϕ 1mm type]	172
■	HL-T1001□ [Dimensions with side view attachment (HL-T1SV1)]	173
■	HL-T1005A [5mm Type].....	174
■	HL-T1005F [5mm type].....	175
■	HL-T1005□ [Dimensions with side view attachment (HL-T1SV1)]	176
■	HL-T1010A [10mm Type].....	177
■	HL-T1010F [10mm type].....	178
■	HL-T1010□ [Dimensions with side view attachment (HL-T1SV2)]	179
■	MS-HLT1-1 [Sensor head mounting bracket for HL-T1001□/HL-T1005□].....	180
■	MS-LA3-1 [Sensor head mounting bracket for HL-T1010□]	181
■	CN-HLT1-1 [Sensor head to controller connection cable].....	182
5.2.2	Controller	183
■	HL-AC1 / HL-AC1P.....	183
■	MS-HLAC1-1 [Controller mounting bracket]	184
5.2.3	Calculation unit.....	185
■	HL-AC1-CL.....	185
5.3	INTENDED PRODUCTS FOR CE MARKING	186

5.1 Ratings / Performance

5.1.1 Sensor head

Type	ϕ 1mm type	5mm type	10mm type
Item Model No.	HL-T1001A	HL-T1005A	HL-T1010A
Applicable controller	HL-AC1, HL-AC1P		
Emitting method	Pulse-modulated		
Sensing range	0 to 2,000mm	0 to 500mm	
Sensing width	ϕ 1mm (Note 1)	5mm	10mm
Min. sensing object	ϕ 8 μ m opaque object (Note 2)	ϕ 0.05mm opaque object	ϕ 0.1mm opaque object
Repeatability	4 μ m (Note 3)	4 μ m (Note 4)	
Linear output resolution (Note 5)	4 μ m (Note 6)	4 μ m (Note 4)	
Emission indicator	Green LED (Lights up during laser emission)		
Ambient temperature	0 to +50°C (No dew condensation), Storage: -25 to +70°C		
Ambient humidity	35 to 85% RH, Storage: 35 to 85% RH		
Emitting element	Red semiconductor laser (peak emission wavelength: 650nm)		
Laser class	Class 1 (JIS / IEC)		
Max. output	0.2mW or less	0.35mW or less	
Material	Case: Polyesterimide, Case cover: Polycarbonate, Front cover: Glass		
Cable extension	Extension up to total 10m is possible, with the exclusive extension cable.		
Weight	Emitter: 15g approx. Receiver: 15g approx.	Emitter: 15g approx. Receiver: 15g approx.	Emitter: 30g approx. Receiver: 20g approx.
Accessories	MS-HLT1-1 (Sensor head mounting bracket): 2 Nos. Laser beam alignment sticker: 2 Nos. Chinese laser class label set :1 set Sensor head control connection cable: 1 No.		MS-LA3-1 (sensor head mounting bracket): 2 Nos. Laser beam alignment sticker: 2 Nos. Chinese laser class label set :1 set Sensor head to controller connection cable: 1 No.

- Notes:1) In case that the detection distance is 0 to 500mm. When it is 500 to 2,000mm, the size is ϕ 1 to ϕ 2.5mm.
- 2) In case that the detection distance is 0 to 500mm. When it is 500 to 2,000mm, the size is ϕ 50 μ m.
- 3) In case of a detection distance of 0 to 500mm, and an average sampling rate of 64 times with the light half cut off. At 32 times, it is 5 μ m.
- 4) In case of an average sampling rate of 64 times. At 32 times, it is 5 μ m.
- 5) Value calculated with the linear output allowance factor ($\pm 3\%$) when connected to the controller included in the calculation of the detection width.
- 6) In case of a detection distance of 0 to 500mm, and an average sampling rate of 64 times. At 32 times, it is 5 μ m. The value calculated imagining a detection width of ϕ 1mm with the light cut off the smallest detection object near the center, and with the allowance ($\pm 3\%$) in the linear output included in the detection width calculation.

5.1.2 Sensor head (FDA Compatible)

Type	ϕ 1mm type	5mm type	10mm type
Item / Model No.	HL-T1001F	HL-T1005F	HL-T1010F
Applicable controller	HL-AC1, HL-AC1P		
Emitting method	Pulse-modulated		
Sensing range	0 to 2,000mm	0 to 500mm	
Sensing width	ϕ 1mm (Note 1)	5mm	10mm
Min. sensing object	ϕ 8 μ m opaque object (Note 2)	ϕ 0.05mm opaque object	ϕ 0.1mm opaque object
Repeatability	4 μ m (Note 3)	4 μ m (Note 4)	
Linear output resolution (Note 5)	4 μ m (Note 6)	4 μ m (Note 4)	
Emission indicator	Green LED (Lights up during laser emission)		
Ambient temperature	0 to +50°C (No dew condensation), Storage: -25 to +70°C		
Ambient humidity	35 to 85% RH, Storage: 35 to 85% RH		
Emitting element	Red semiconductor laser (peak emission wavelength: 650nm)		
Laser class	Class 2 (FDA) Class 1 (JIS / IEC)		
Max. output	0.2mW or less	0.35mW or less	
Material	Case: Polyesterimide, Case cover: Polycarbonate, Front cover: Glass		
Cable extension	Extension up to total 10m is possible, with the exclusive extension cable.		
Weight	Emitter: 15g approx. Receiver: 15g approx.	Emitter: 15g approx. Receiver: 15g approx.	Emitter: 30g approx. Receiver: 20g approx.
Accessories	MS-HLT1-1 (Sensor head mounting bracket): 2 Nos. Laser beam adjustment sticker: 2 Nos. Sensor head control connection cable: 1 No. Chinese laser class label set :1 set Label set: 1 No.		MS-LA3-1 (sensor head mounting bracket): 2 Nos. Laser beam adjustment sticker: 2 Nos. Sensor head to controller connection cable: 1 No. Chinese laser class label set :1 set Label set: 1 No

- Notes:1) In case that the detection distance is 0 to 500mm. When it is 500 to 2,000mm, the size is ϕ 1 to ϕ 2.5mm.
- 2) In case that the detection distance is 0 to 500mm. When it is 500 to 2,000mm, the size is ϕ 50 μ m.
- 3) In case of a detection distance of 0 to 500mm, and an average sampling rate of 64 times with the light half cut off. At 32 times, it is 5 μ m
- 4) In case of an average sampling rate of 64 times. At 32 times, it is 5 μ m.
- 5) Value calculated with the linear output allowance factor ($\pm 3\%$) when connected to the controller included in the calculation of the detection width.
- 6) In case of a detection distance of 0 to 500mm, and an average sampling rate of 64 times. At 32 times, it is 5 μ m. The value calculated imagining a detection width of ϕ 1mm with the light cut off the smallest detection object near the center, and with the allowance ($\pm 3\%$) in the linear output included in the detection width calculation.

5.1.3 Controller

Type	NPN Output Type	PNP Output Type
Item / Model No.	HL-AC1	HL-AC1P
Applicable sensor Head	HL-T1001A, HL-T1005A, HL-T1010A HL-T1001F, HL-T1005F, HL-T1010F	
Supply voltage	12 to 24V DC $\pm 10\%$ Ripple P - P: 10% or less	
Current consumption	190mA or less (when connected to the sensor head)	
Measuring cycle	150 μ s	
Linear output	Current / voltage output switchable (Note 1) During current output: 4 to 20mA / F.S. Maximum load impedance: 300 Ω During voltage output: $\pm 4V$ / F.S. Output impedance 100 Ω (In the monitor focus function, it can also be set at $\pm 5V$, 0 to 5V, etc.)	
Temperature characteristics	$\pm 0.2\%$ F.S. / $^{\circ}C$ (Note 2)	
Settable average sampling rate (Note 3)	1 to 4,096 (13 steps)	
Judgment output	NPN transistor open collector <ul style="list-style-type: none"> • Maximum sink current: 50mA • Applied voltage: 30V DC or less (between judgment output and 0V) • Residual voltage: 1.2V or less (at 50mA sink current) 	PNP transistor open collector <ul style="list-style-type: none"> • Maximum sink current: 50mA • Applied voltage: 30V DC or less (between judgment output and +V) • Residual voltage: 2V or less (at 50mA source current)
Number of outputs	HIGH / PASS / LOW 3 values output.	
Output operation	ON when the received beam level reaches the threshold value.	
Short circuit protection	Incorporated	
Laser OFF input	0V connection: Laser emission stop Open: Laser emission <ul style="list-style-type: none"> • Applied voltage: 30V DC or less (at 0.1mA leak current) 	+V connection: Laser emission stop Open: Laser emission <ul style="list-style-type: none"> • Applied voltage: 30V DC or less (at 0.1mA leak current)
Zero reset input	0V connection: Zero reset operates Open: Zero reset disabled <ul style="list-style-type: none"> • Applied voltage: 30V DC or less (at 0.1mA leak current) 	+V connection: Zero reset operates Open: Zero reset disabled <ul style="list-style-type: none"> • Applied voltage: 30V DC or less (at 0.1mA leak current)
Timing input	0V connection: Enabled Open: Disabled <ul style="list-style-type: none"> • Applied voltage: 30V DC or less (at 0.1mA leak current) 	+V connection: Enabled Open: Disabled <ul style="list-style-type: none"> • Applied voltage: 30V DC or less (at 0.1mA leak current)

Reset input		0V connection: Enabled Open: Disabled · Applied voltage: 30V DC or less (at 0.1mA leak current)	+V connection: Enabled Open: Disabled · Applied voltage: 30V DC or less (at 0.1mA leak current)	
Indicators	Laser indicator	Green LED (lights during laser emission)		
	Judgment output	HIGH: Orange LED (Measurement value > HIGH threshold value) PASS: Green LED (LOW threshold value ≤ Measurement value ≤ HIGH threshold value) LOW: Yellow LED (LOW threshold value < Measurement value)		
	Enable	Green LED (Lights up during normal operation)		
	Zero reset	Green LED (Lights up when the zero reset function is enabled)		
Main digital display		5-digit red LED display		
Sub-digital display		5-digit yellow LED display		
Ambient temperature		0 to +50°C (No dew condensation), Storage: -25 to +65°C		
Ambient humidity		35 to 85% RH, Storage: 35 to 85% RH		
Ground system		Floating ground		
Material		Case: Polybutylene terephthalate Transparent cover: Polycarbonate		
Weight		140g approx.		
Major functions		<ul style="list-style-type: none"> ◆ Measurement value display ◆ Setting value, light intensity, value resolution display ◆ Standard light reception intensity setting ◆ Auto scaling ◆ Scaling ◆ Display reverse ◆ Display off mode ◆ ECO mode ◆ Display digits change ◆ Sample hold ◆ Peak hold ◆ Bottom hold ◆ Peak to peak hold ◆ Average hold 	<ul style="list-style-type: none"> ◆ Self-up trigger ◆ Self-down trigger ◆ Zero reset ◆ Initial reset ◆ On delay timer ◆ Off delay timer ◆ One shot timer ◆ Differentiation ◆ Previous value comparison ◆ Sensitivity selection ◆ Threshold value direct setting 	<ul style="list-style-type: none"> ◆ Positioning teaching ◆ 2-point teaching ◆ Automatic teaching ◆ Hysteresis width variability ◆ Monitor focus ◆ Linear output correction ◆ Non-measuring time setting ◆ (A - B) calculation (Note 4) ◆ (A + B) calculation (Note 4) ◆ Thickness measurement (Note 4) ◆ Mutual interference prevention (Note 4) ◆ Laser deterioration detection ◆ Lock function ◆ Zero reset memory

- Notes: 1) Switching between current and voltage is accomplished by a switch on the bottom of the controller.
- 2) These are the temperature characteristics of the linear output when the sensor head is connected.
- 3) The judgment output and linear output response time is calculated by (Measuring cycle) x (Set average sampling rate + 1).
- 4) The calculation unit is necessary. The controller with the software Ver.3 or later and the controller with the software earlier than Ver.3 cannot be used in combination.

5.1.4 Calculation unit

Type	Calculation unit
Item Model No.	HL-AC1-CL
Connected controller	HL-AC1, HL-AC1P
Current consumption	12mA or less (supplied from the controller)
Connection method	Connector
Connection indicator	Orange LED (Lights up when connected to the controller)
Ambient temperature	0 to +50°C (No dew condensation and freezing) Storage: -15 to +60°C
Ambient humidity	35 to 85% RH, Storage: 35 to 85% RH
Grounding method	Floating ground
Material	Surface: Acryl, Case: ABS
Weight	50g approx.

5.2 Dimensions

5.2.1 Sensor head

■ HL-T1001A [$\phi 1\text{mm}$ type]

(Units: mm)

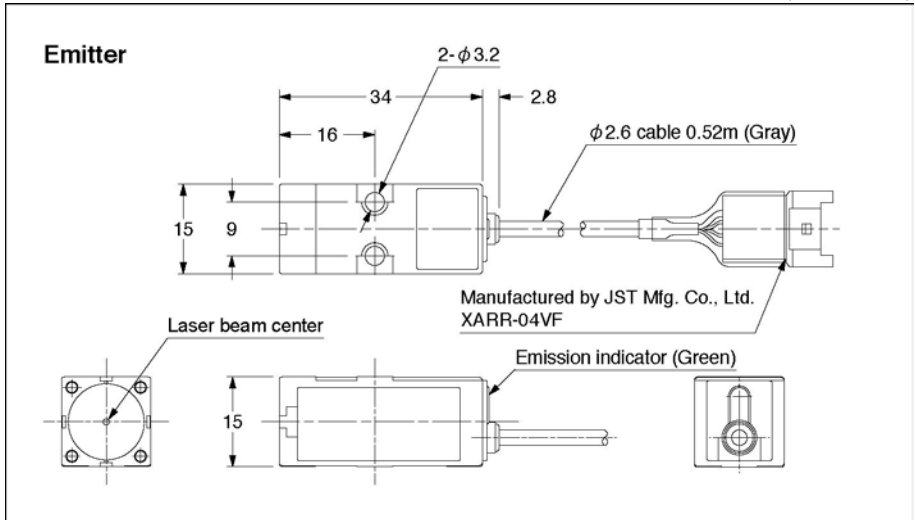

(Units: mm)

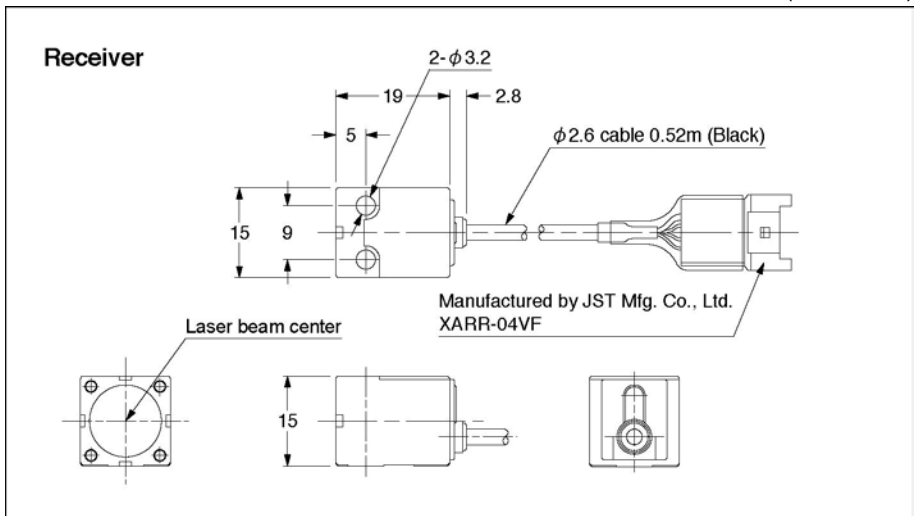

■ HL-T1001F [ϕ 1mm type]

(Units: mm)

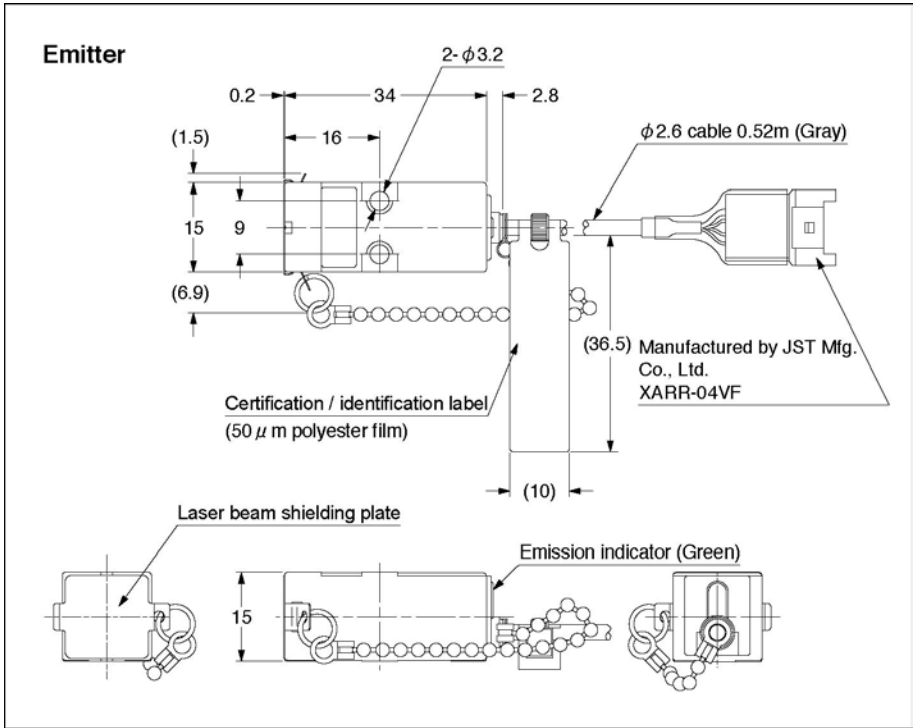

(Units: mm)

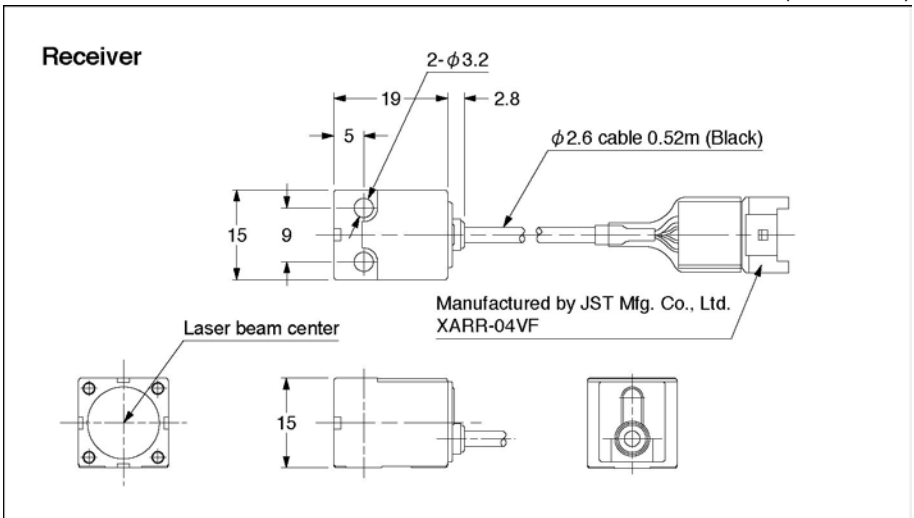

■ HL-T1001□ [Dimensions with side view attachment (HL-T1SV1)]

(Units: mm)

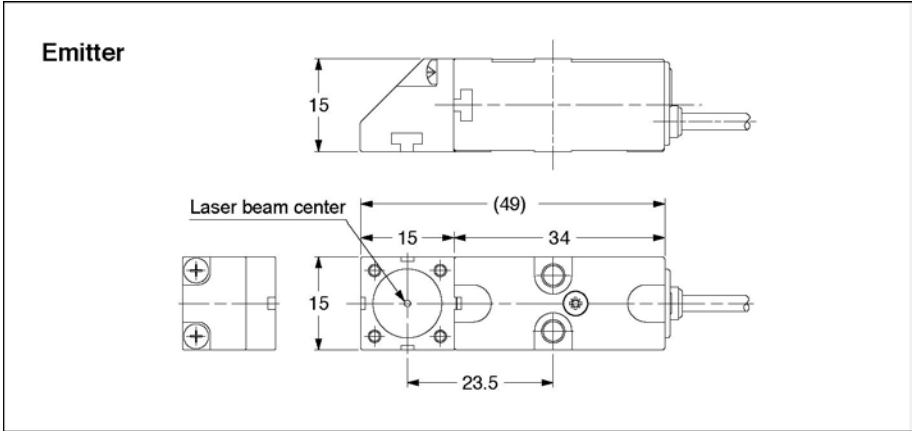

(Units: mm)

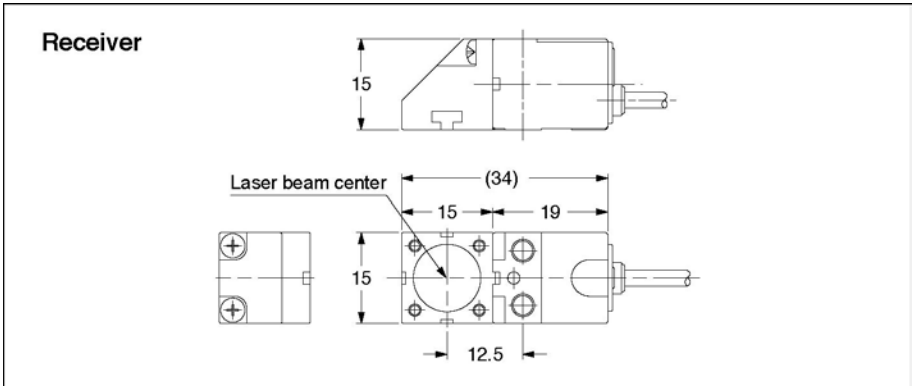

■ HL-T1005A [5mm Type]

(Units: mm)

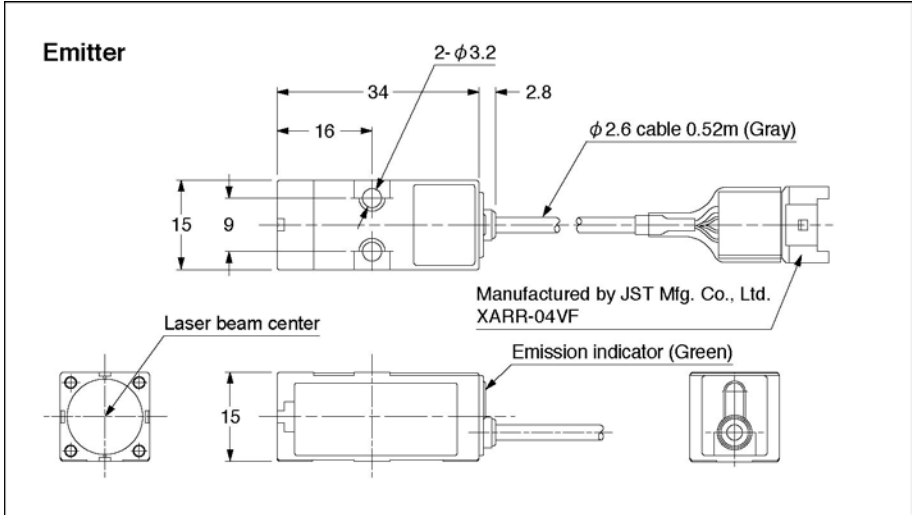

(Units: mm)

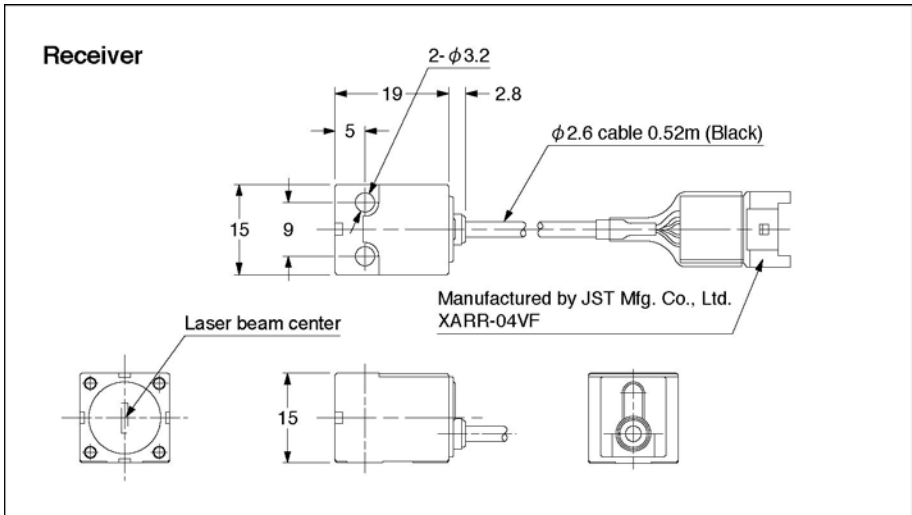

■ HL-T1005F [5mm type]

(Units: mm)

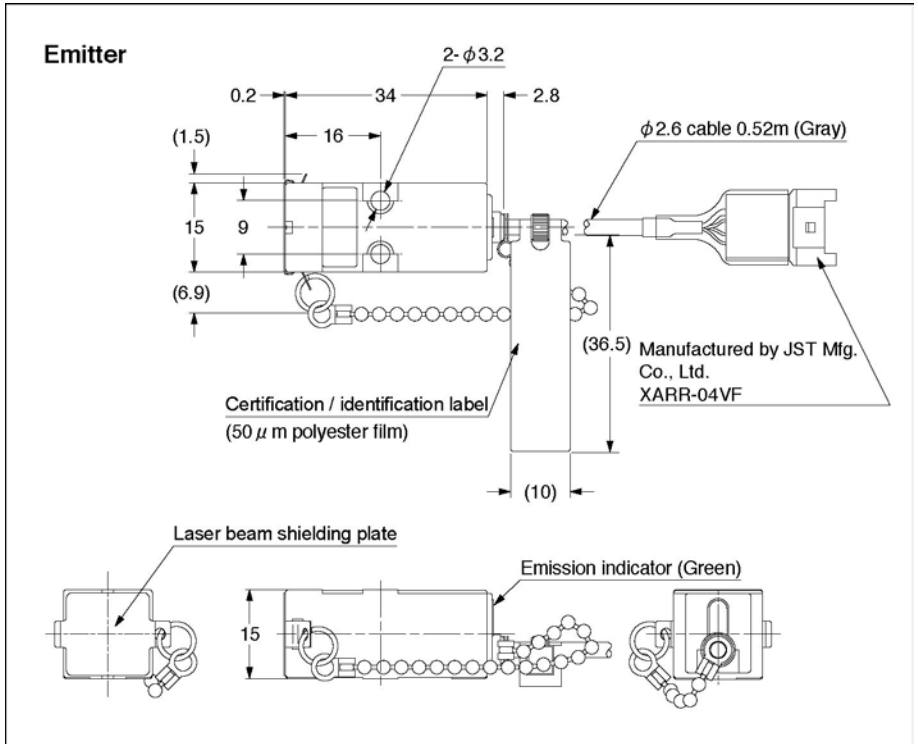

(Units: mm)

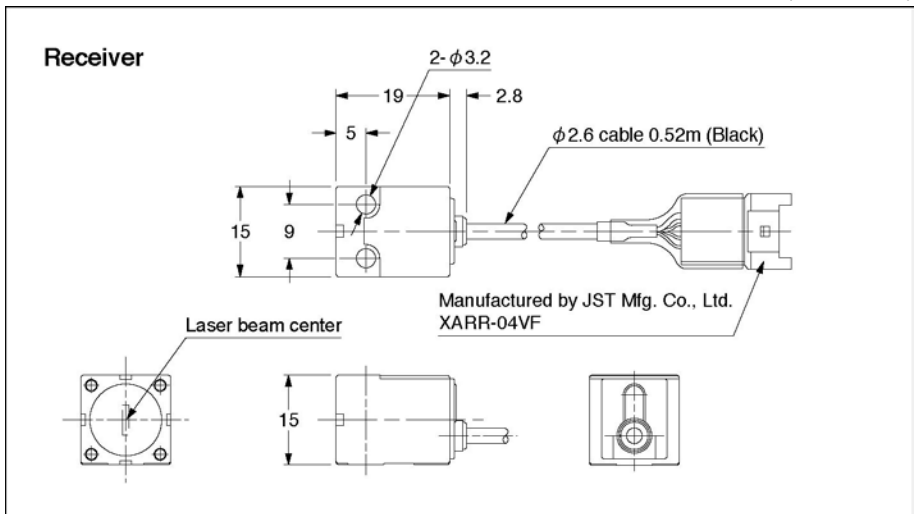

■ HL-T1005□ [Dimensions with side view attachment (HL-T1SV1)]

(Units: mm)

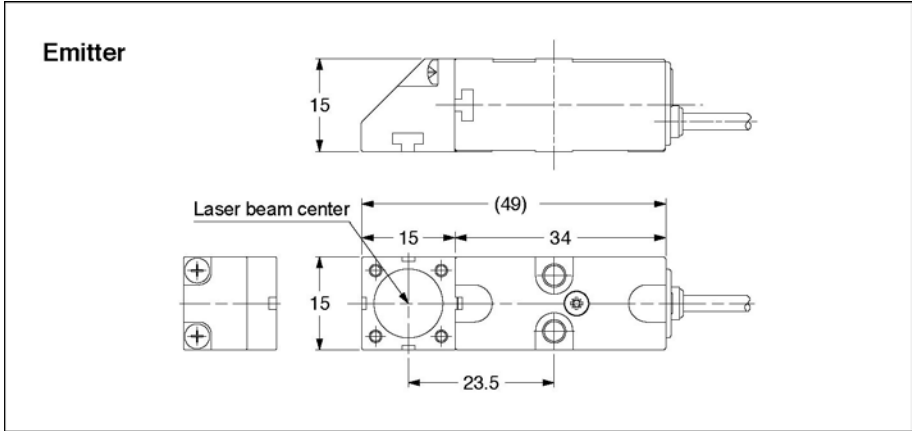

(Units: mm)

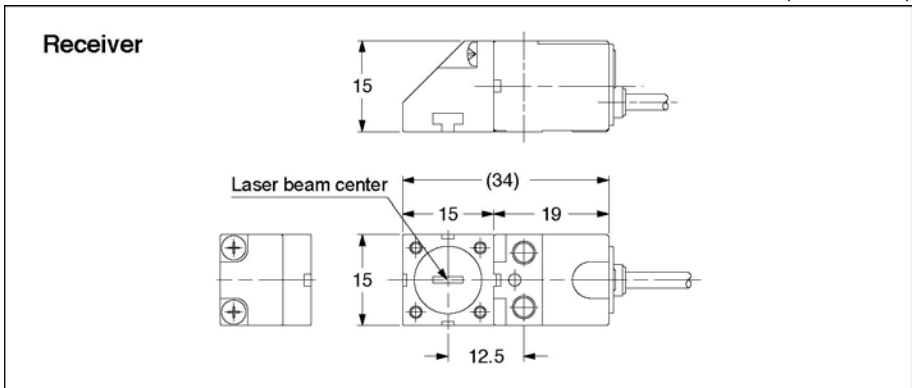

■ HL-T1010A [10mm Type]

(Units: mm)

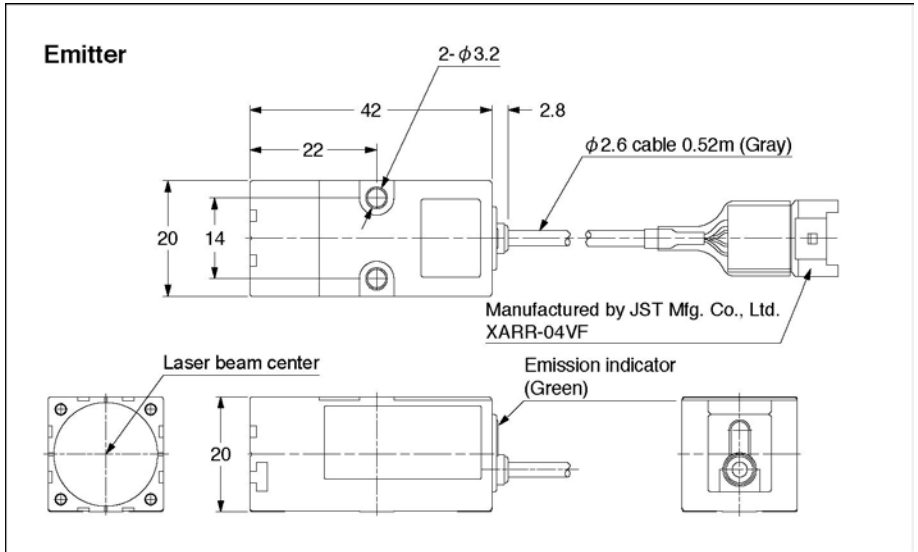

(Units: mm)

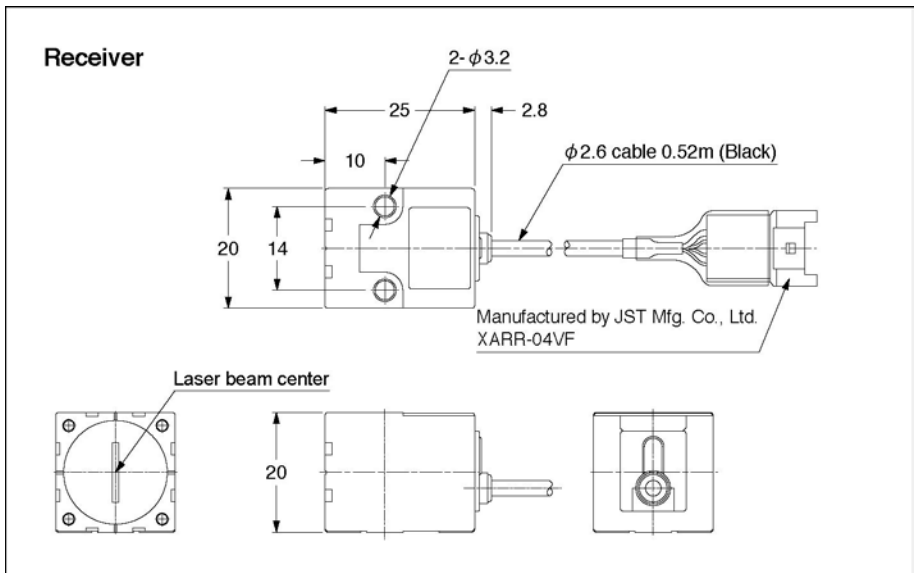

■ HL-T1010F [10mm type]

(Units: mm)

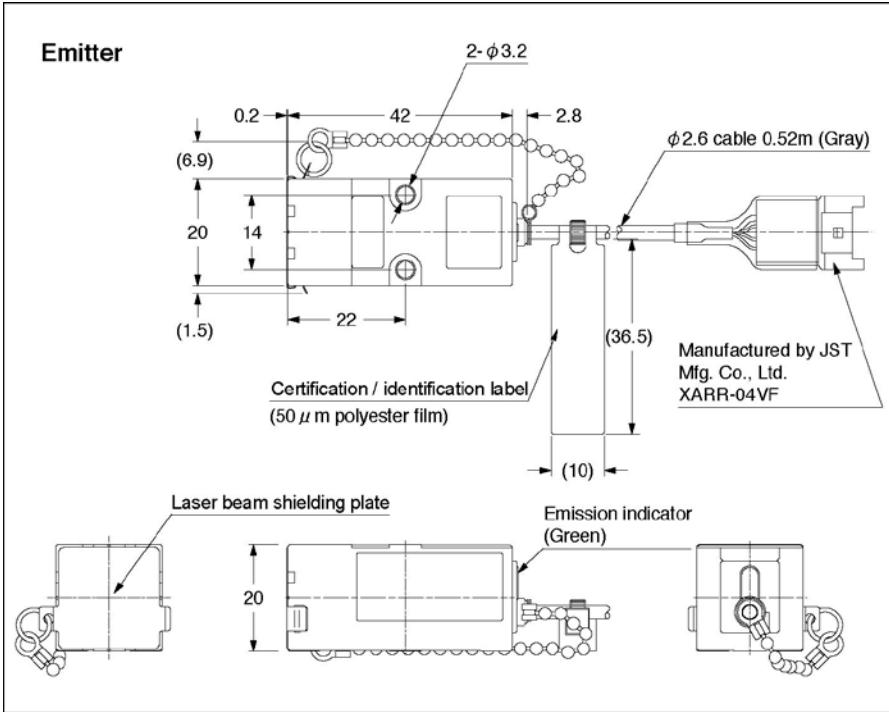

(Units: mm)

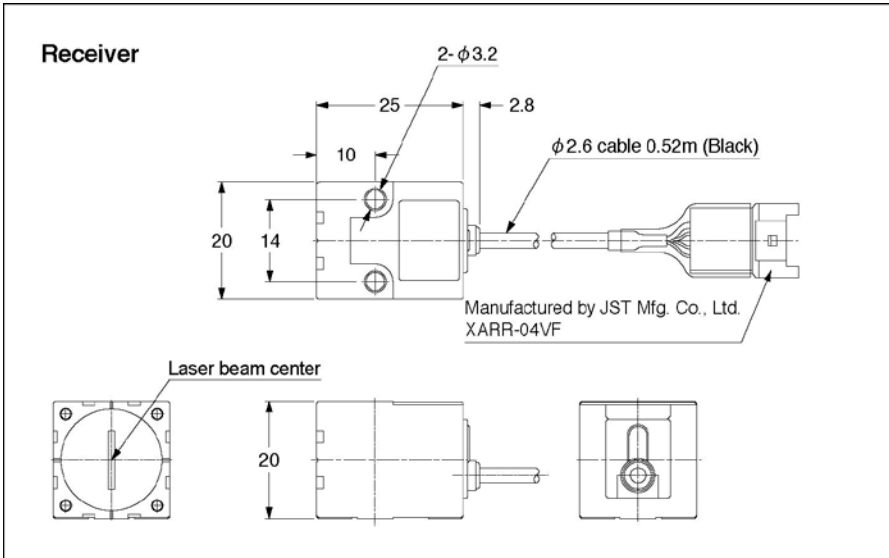

■ HL-T1010□ [Dimensions with side view attachment (HL-T1SV2)]

(Units: mm)

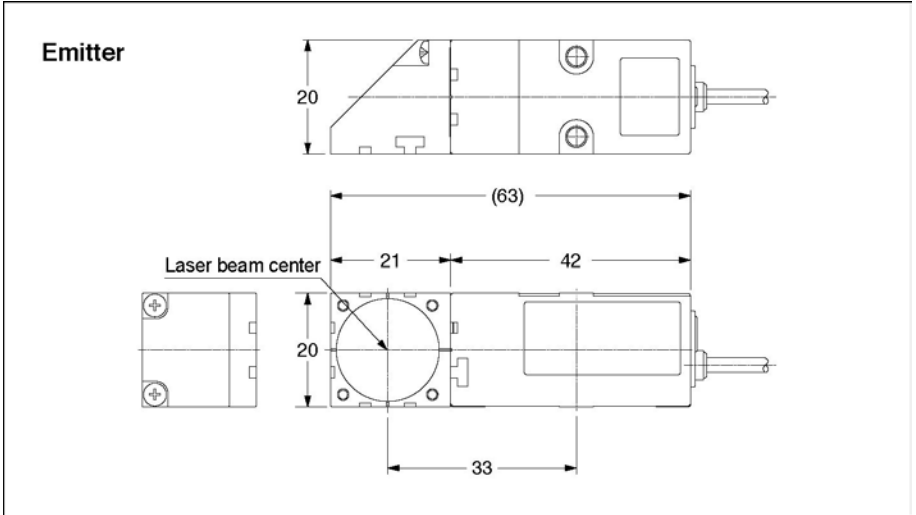

(Units: mm)

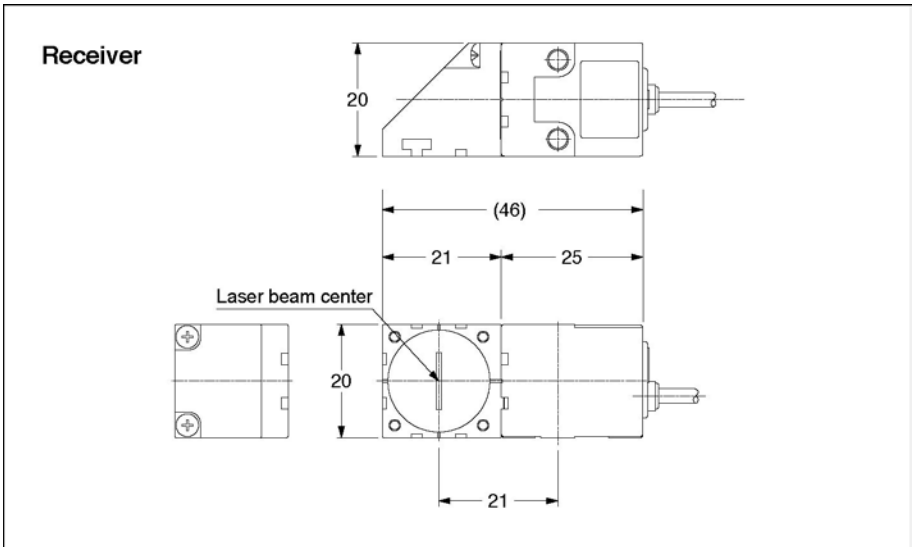

■ CN-HLT1-1 [Sensor head to controller connection cable]

(Units: mm)

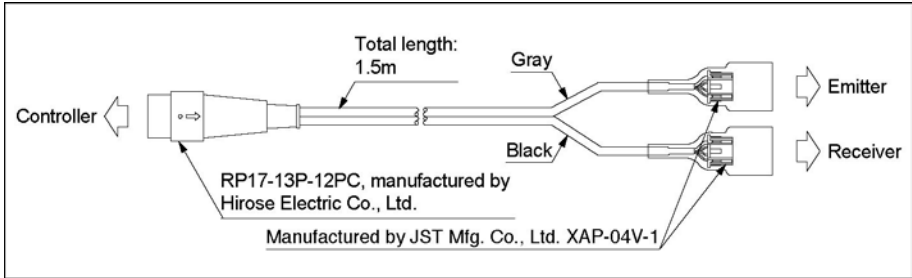

5.2.2 Controller

■ HL-AC1 / HL-AC1P

(Units: mm)

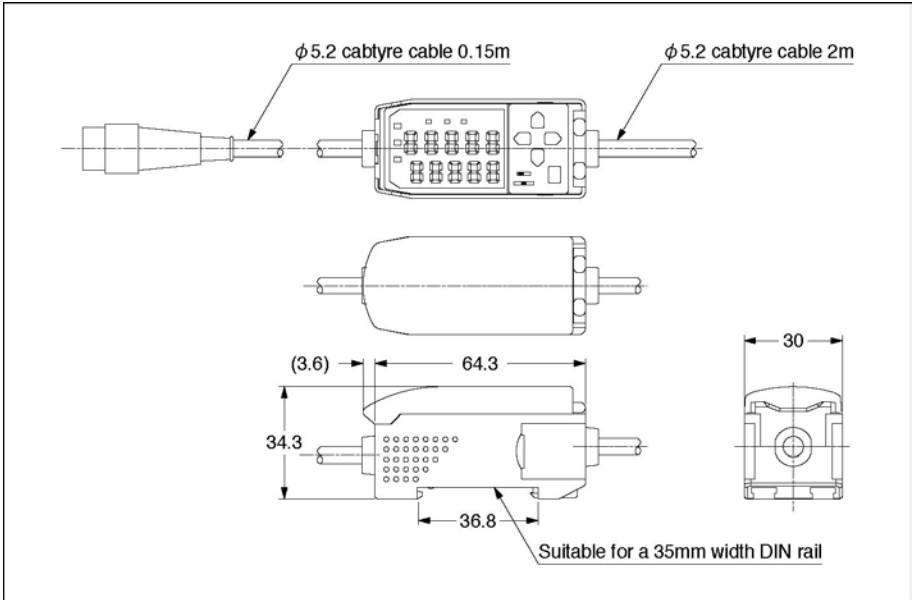

[Dimension with connector cover open]

(Units: mm)

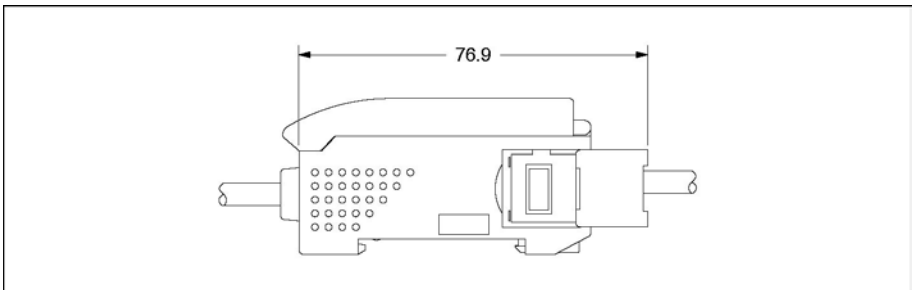

■ MS-HLAC1-1 [Controller mounting bracket]

(Units: mm)

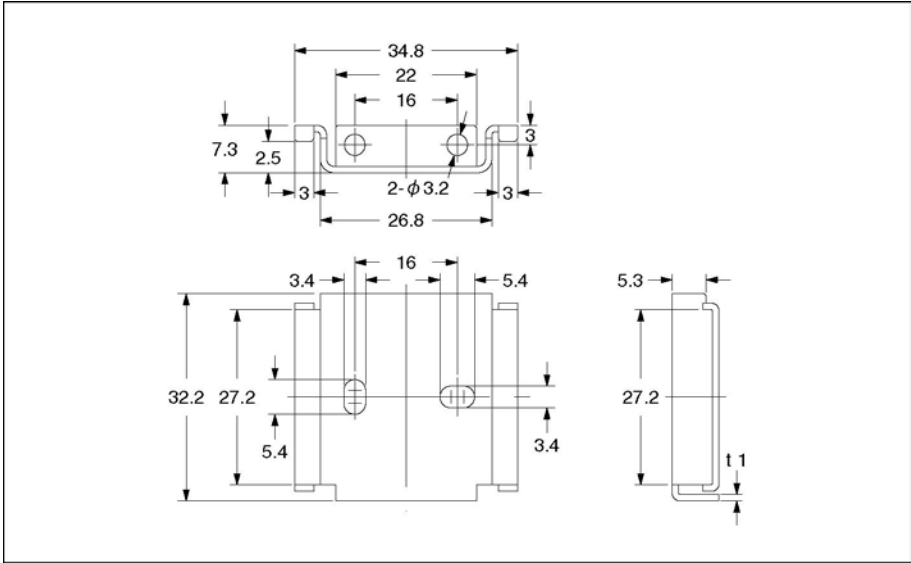

(Units: mm)

Assembly dimensions

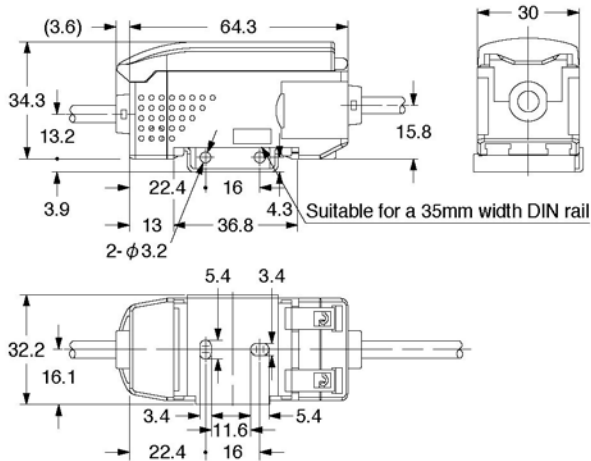

5.2.3 Calculation unit

■ HL-AC1-CL

(Units: mm)

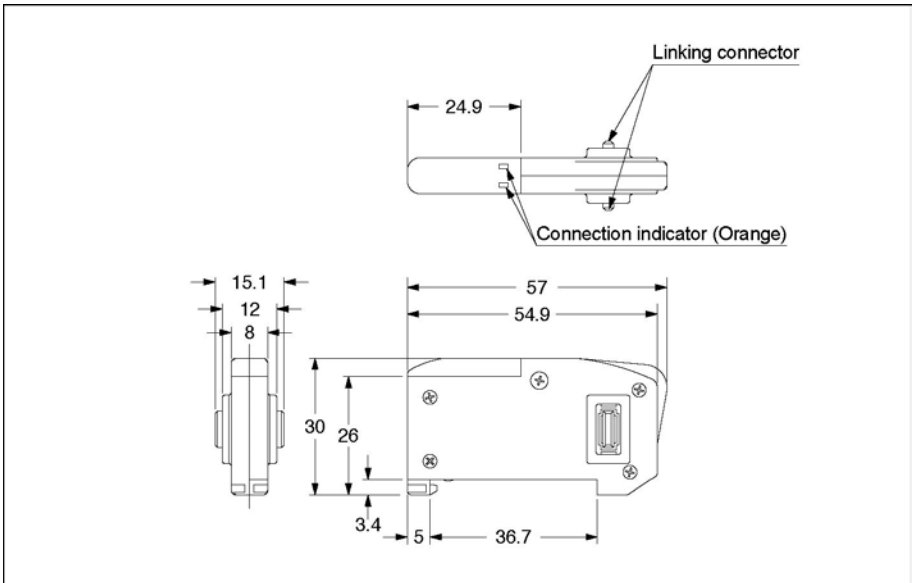

5.3 INTENDED PRODUCTS FOR CE MARKING

The models listed under '**CHAPTER 5 SPECIFICATIONS AND DIMENSIONS**' come with CE Marking.

As for all other models, please contact our office.



Contact for CE

Panasonic Marketing Europe GmbH Panasonic Testing Center
Winsbergring 15, 22525 Hamburg, Germany

APPENDIX

FUNCTION INDEX

FUNCTION INDEX

Reference Page

(A)

- **Adjacent sensor calculation** • Using the calculation unit, "Sum (A + B)", "Difference (A-B)", and "Thickness" between 2 controller units are calculated. P.134
 - **Auto scaling function** • The display value is set for the light reception volume. P.102
 - **Automatic teaching** • The threshold value is set automatically from the maximum and minimum values during teaching. P.93
 - **Average sampling rate** • Changes the average sampling rate. P.111
-

(B)

- **Bottom hold** • Holds the minimum value of the measuring values from the measuring period defined by the timing input. P.116
-

(C)

- **Clamp setting** • Sets the linear output values in the non-measuring state. P.157
-

(D)

- **Differential function** • Outputs the amount of change in the measurement values at the set measuring frequency. P.148
 - **Display digits limitation** • Changes the number of display digits in the digital display. P.155
 - **Display reverse function** • Reverses the top and bottom contents in the digital display. P.153
-

(E)

- **ECO display function** • The digital display enters the energy saving mode and the lighting becomes dark. P.154
-

(G)

- **Gain switching** • Changes the light reception gain. P.159
-

(H)

- **Hold** • A function that enables measuring values to be held. P.112
 - **Hysteresis width setting** • Changes the hysteresis width of the judgment output. P.112
-

(K)

- **Key lock function** • Disables key input. P.160
-

(L)

- **Linear output correction** • Corrects the linear output values of control- P.144
 lers to the values measured by an external
 device (ammeter/voltmeter) that are used as
 the reference.

(M)

- **Monitor focus function** • The range and inclination of the linear output P.140
 is set to the desired value.

(N)

- **Non-measuring time setting** • Sets the output when in the non-measuring P.156
 state, such as the reset time.
- **Normal hold** • This is the hold function in the Off state. P.114

(P)

- **Peak hold** • Holds the maximum value of the measure- P.115
 ment values obtained during the period de-
 fined by the timing input.
- **Peak to peak hold** • Holds the peak to peak value from the P.118
 measurement values obtained during the
 period defined by the timing input.
- **Positioning teaching** • The value used for teaching becomes the P.88
 threshold value.
- **Previous value comparison** • Outputs the difference with the previous P.150
 hold value as the measurement value.

(S)

- **Sample hold** • Holds the value sampled at the instant that P.117
 the timing signal was input.
- **Scaling function** • Sets the measurement value display to the P.104
 desired value.
- **Self-down trigger** • Holds the minimum value of the measure- P.124
 ment values below the threshold value
 measured during the measuring period in
 combination with the bottom hold.
- **Self-up trigger** • Holds the maximum value of the measure- P.123
 ment values above the threshold value
 measured during the measuring period in
 combination with the peak hold.
- **Setting initialization** • Returns the settings to the default values P.138
 set at the time of factory shipment.
- **Standard light reception
 intensity setting** • Records the light reception intensity in the P.83
 installation state as the standard light re-
 ception intensity.
- **Sub-digital display change** • Changes the contents of the sub-digital display. P.76

Memo

Revision History

First edition: June, 2019 For controller software Ver.3.

Please contact

Panasonic Industrial Devices SUNX Co., Ltd.

■ Overseas Sales Division (Head Office): 2431-1 Ushiyama-cho, Kasugai-shi, Aichi, 486-0901, Japan
■ Telephone: +81-568-33-7861 ■ Facsimile: +81-568-33-8591

panasonic.net/id/pidsx/global

For sales network, please visit our website.