

Amplifier Built-in Ultra-slim
Photoelectric sensor

EX-10 Series USER'S MANUAL

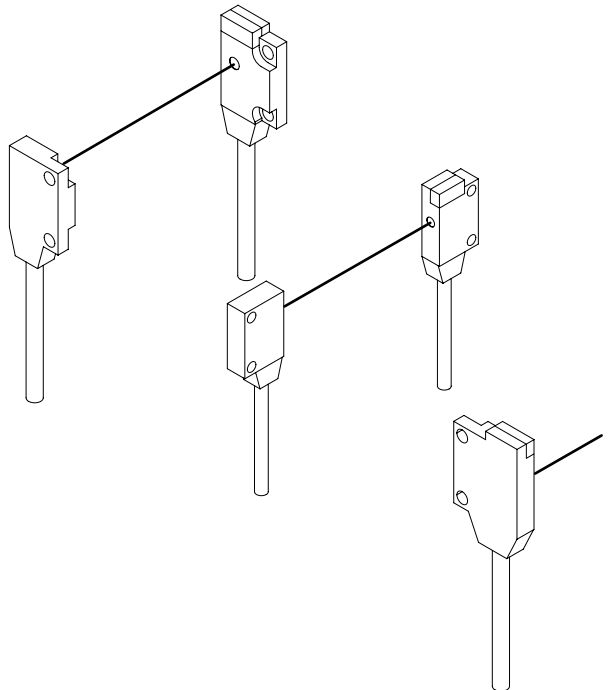

Thank you for purchasing an **EX-10** series amplifier built-in ultra slim photoelectric sensor.
Read this document carefully and thoroughly for the correct and optimum use of this product.
Keep this document in a convenient place for quick reference.

Please note

- 1) No part of this document should be copied or reprinted in any form or by any means without prior permission in writing from the publisher.
- 2) The contents of this document are subject to change without notice for future improvement.
- 3) Every effort is made to produce this document. If you find any question, error, incorrect collating and/or missing page, please do not hesitate to contact our nearest local office to you: Panasonic Industry.
- 4) This document (Japanese and English) is an original publication.

1. Introduction

The **EX-10** series (**EX-11**□ / **EX-13**□ / **EX-19**□ / **EX-14**□) conforms to the international standard ISO 13849-1:2015 (Category 1, PLC) and can be used as a detection device to indirectly protect the human body.

"When Using for Safety Applications" on Page 30 contains safety information related to the **EX-11**□ / **EX-13**□ / **EX-19**□ / **EX-14**□ when used as part of a safety system.

When using with compatible products for safety applications, be sure to read this document in addition to the instruction manuals included with those devices.

The content of "When Using for Safety Applications" applies to the following persons who have received appropriate training and have knowledge of photoelectric safety sensors.

- Those who are in charge of introduction of this device.
- Those who incorporate this device into systems or design them.
- Those who install and/or connect this device.
- Those who manage or perform operations at sites where this device is used.

Do not use the **EX-15**□ / **EX-17**□ for either the direct detection of human forms or for the indirect protection of the human body.

Before using this device, be sure to read Chapters 2 through 13 (page 5 to 24) of this document in addition to the instruction manuals included with other devices used in the system.

2. Safety Precautions Always observe

This manual explains important rules that must be observed to prevent personal injury and property damage.

- The hazards that may occur if the product is used incorrectly are described and classified by level of harm.

 **WARNING** Risk of death or serious injury.

WARNING

- Do not use this product for an application where it directly detects the human body. Otherwise, there is a risk of death or serious injury.
- When the human body needs to be detected for safety application, use products that conform to the laws and standards related to human body detection for safety application in each country, such as OSHA, ANSI, and IEC.

3. Precaution

- This product has been developed / produced for industrial use only.
- The narrow beam type **EX-1□S□** emits a narrow light beam, so it is difficult to align the beam. Use the instrument with the emitter and the receiver facing each other in a straight line. Note that if screws or other parts become loose due to vibration, for example, the beam axis may drift.
- Sensor mounting bracket (optional) **MS-EX-10-□** is a bracket for standard-beam type. It cannot be used for narrow-beam type.
- For the convergent reflective type **EX-14□**, if there is a reflective object (e.g., a conveyor, etc.) in the background of the sensing object, since it may affect the sensing, use by keeping enough distance from the reflective object.
- The thin cable 0.1mm² is used for this product. Thus, take care that if the cable is pulled with excessive force, it may cause cable break.
- Extension up to total 50m (each emitter and receiver of thru-beam type), or less, is possible with 0.3mm², or more of conductor area cable. When using for safety applications, use a cable that is 30m or less in length.
- The extension of a power supply line and the output line of less than 10m is acceptable in case using this product as conforming to S-mark.
- Make sure that stress by forcible bend or pulling is not applied directly to the sensor cable joint.
- Make sure to carry out wiring in the power supply off condition.
- Take care that wrong wiring will damage the sensor.
- Verify that the supply voltage variation is within the rating.
- If power is supplied from a commercial switching regulator, ensure that the frame ground (F.G.) terminal of the power supply is connected to an actual ground.
- In case noise generating equipment (switching regulator, inverter motor, etc.) is used in the vicinity of this product, connect the frame ground (F.G.) terminal of the equipment to an actual ground.
- Do not run the wires together with high-voltage lines or power lines, or put them in the same race-way.
- Take care that the sensor is not directly exposed to fluorescent lamp from a rapid-starter lamp, a high frequency lighting device or sunlight etc., as it may affect the sensing performance.
- Do not use during the initial transient time (**EX-15□**, **EX-15E□**, **EX-17□**, **EX-17E□**: 100ms / others: 50ms) after the power supply is switched ON.
- This sensor is suitable for indoor use only.
- Do not use this sensor in places having excessive vapor, dust, etc., or where it may come in contact with corrosive gas, etc.
- Take care that the product does not come in contact with oil, grease, organic solvents such as thinner, etc., strong acid or alkaline.
- This product cannot be used in an environment containing inflammable or explosive gasses.
- Never disassemble or modify the product.
- Since the cable end is not waterproof, do not use the sensor in the application where water may seep in from the cable end.

4. Regulations and Standards

This product conform to the following standards and regulations.(The **EX-15**□/**EX-17**□ is excluded from this.)

<Conformity Directives / Conforming Regulations>

EU Law:EMC Directive 2014/30/EU

British Legislation:EMC Regulations 2016/1091

- Applicable Standards

EN IEC 60947-5-2

<Other Standards>

ISO 13849-1:2015(Category 1, PLc)

5. Model No.

■ EX-11□ / EX-13□ / EX-19□ / EX-14□

EX-1 **A** **B** **C** **D** - **E** - **F**

A Sensing distance

1: Thru-beam type (150 mm), 3: Thru-beam type (500 mm), 4: Convergent reflective type,
9: Thru-beam type (1 m)

B Beam type

None: Standard-beam, S: Narrow-beam

C Sensing surface

None: Front sensing, E: Side sensing

D Output operation

A: Light-ON, B: Dark-ON

E Comparative output

None: NPN output, PN: PNP output

F Cable

None: Standard cable (Length: 2 m), C5: Standard cable (Length: 5 m),
R: Flexible cable (Length: 2 m)

■ EX-15□ / EX-17□

EX-1 **A** **B** - **C**

A Sensing distance

5: Thru-beam with operation mode switch on bifurcation (Sensing distance: 150 mm),
7: Thru-beam with operation mode switch on bifurcation (Sensing distance: 500 mm)

B Sensing surface

None: Front sensing, E: Side sensing

C Cable length

None: 2 m, C5: 5 m

**Thru-beam front sensing type with operation mode switch on bifurcation:
EX-15, EX-17**

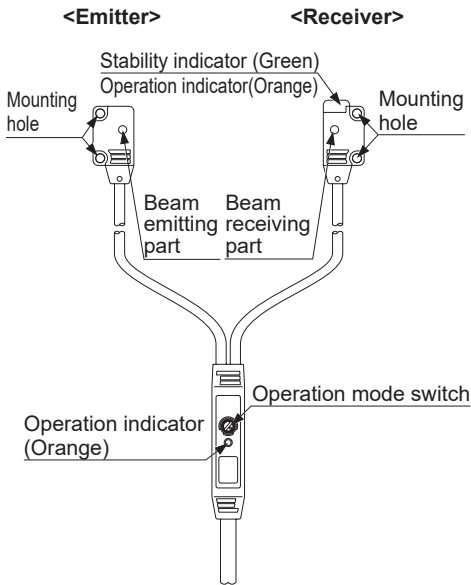

**Thru-beam side sensing type with operation mode switch on bifurcation:
EX-15E, EX-17E**

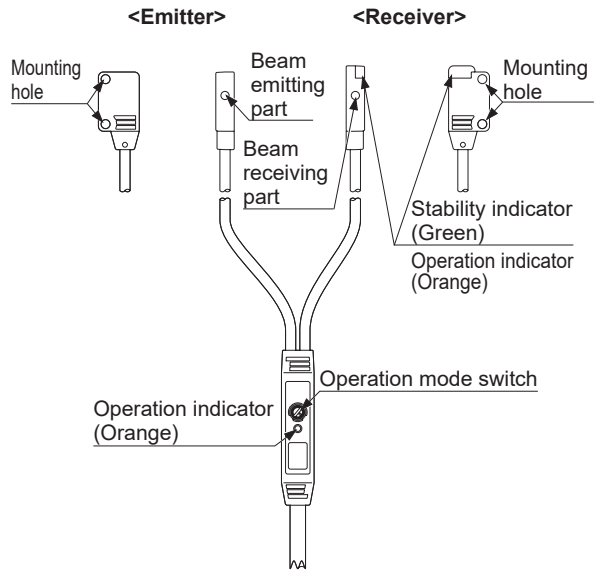

<Operation mode switch>

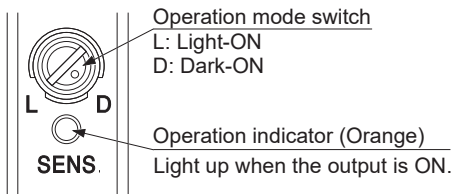

| Switch position | Operation | Description |
|-----------------|-----------|--|
| | Light-ON | Light-ON mode is set when the switch is turned fully clockwise (L side). |
| | Dark-ON | Dark-ON mode is set when the switch is turned fully counterclockwise (D side). |

7. Mounting

7-1 Mounting of the sensor

- The tightening torque should be 0.2 N·m or less.
- The narrow beam type EX-1□S□ emits a narrow light beam, so it is difficult to align the beam. Note that if screws or other parts become loose due to vibration, for example, the beam axis may drift.
- In case of mounting on tapped holes (Unit: mm)

Front sensing

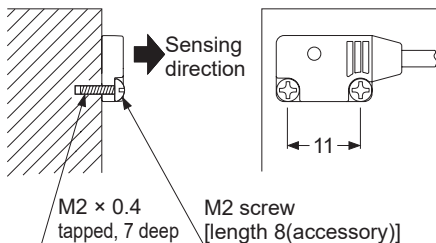

Side sensing

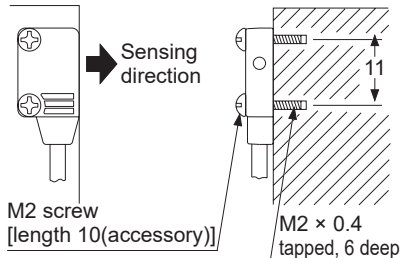

- In case of using attached screws and nuts (Unit: mm)

Front sensing

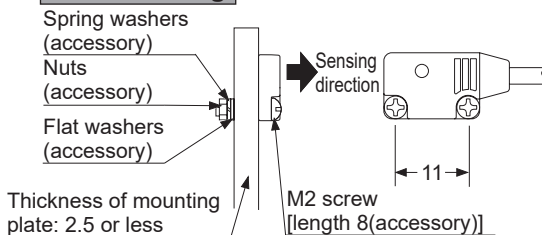

Side sensing

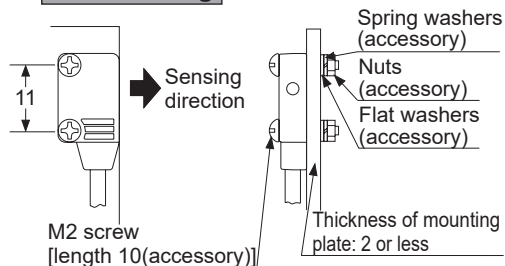

- In case of using mounting bracket (optional)

The sensor bracket is an object for standard-beam type. It cannot be used for narrow-beam type.

MS-EX-10-1

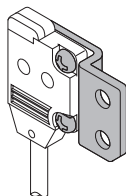

Material: SPCC (Uni-chrome plated)
Two M2 (length 4 mm) pan head screws (Accessory)

MS-EX-10-2

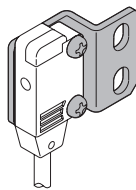

Material: SPCC (Uni-chrome plated)
Two M2 (length 8 mm) pan head screws (Accessory)

MS-EX-10-3

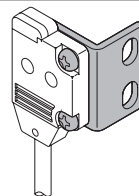

Material: SPCC (Uni-chrome plated)
Two M2 (length 4 mm) pan head screws
Two M2 (length 8 mm) pan head screws
Accessory: 2 pan head screws each

MS-EX-10-11

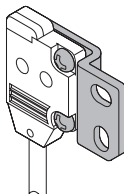

Material: SUS304
Two M2 (length 4 mm) pan head screws (Accessory)

MS-EX-10-12

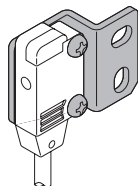

Material: SUS304
Two M2 (length 8 mm) pan head screws (Accessory)

MS-EX-10-13

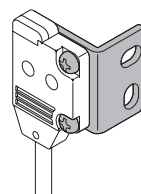

Material: SUS304
Two M2 (length 4 mm) pan head screws SUS304
Two M2 (length 8 mm) pan head screws SUS304
Accessory: 2 pan head screws each

7-2 Mounting interval

- This product does not incorporate auto interference function. In case mounting two sets or more of the this product close together, please mount them as drawing below indicates (typical example)
- Find out the operating point ℓ on the parallel deviation diagram for the setting distance L. Separate sensors by $2 \times \ell$ or more.

Thru-beam type: EX-11□, EX-15□, parallel deviation diagram (typical)

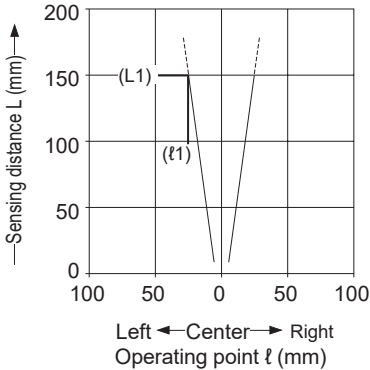

EX-11□, EX-15□: Approx. 46.8mm or more

EX-11□, EX-15□: Approx. 46.8mm or more

<Installation interval for EX-11□, EX-15□>

In case using at sensing distance (L1) 150mm, the operation point (ℓ_1) is approx. 23.4mm according to diagram above.

The installation interval is

Approx. 23.4mm \times 2 = approx. 46.8mm

Thus, install approx.46.8mm or more away.

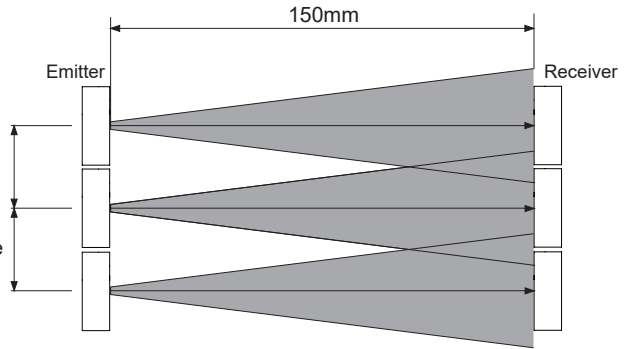

Thru-beam type: EX-11E□, EX-15E□, parallel deviation diagram (typical)

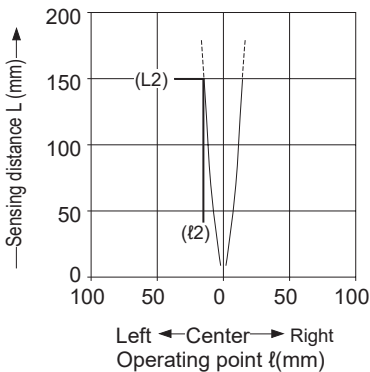

EX-11E□, EX-15E□: Approx. 30mm or more

EX-11E□, EX-15E□: Approx. 30mm or more

<Installation interval for EX-11E□, EX-15E□>

In case using at sensing distance (L2) 150mm, the operation point (ℓ_2) is approx. 15mm according to diagram above.

The installation interval is

Approx. 15mm \times 2 = approx. 30mm

Thus, install approx. 30mm or more away.

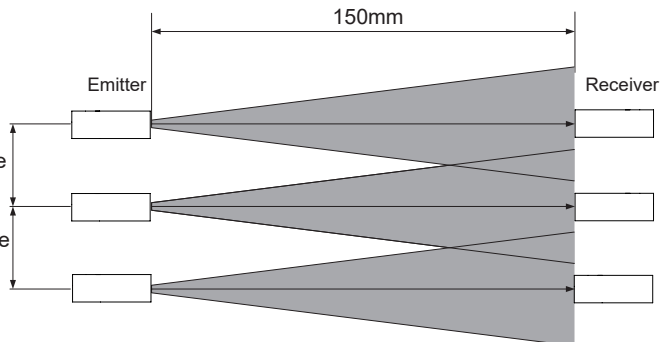

Thru-beam type: EX-13□, EX-17□ parallel deviation diagram (typical)

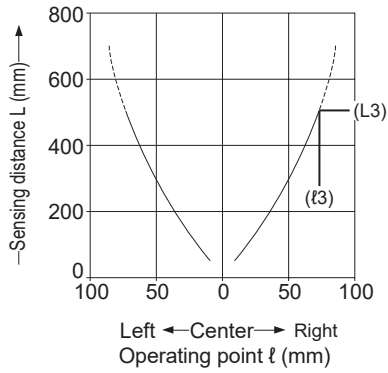

EX-13□, EX-17□ approx. 153.2mm or more

EX-13□, EX-17□ approx. 153.2mm or more

<Installation interval for EX-13□, EX-17□>
In case using at sensing distance ($L3$) 500mm, the operation point ($l3$) is approx. 76.6mm according to diagram above.

The installation interval is

Approx. $76.6\text{mm} \times 2 =$ approx. 153.2mm

Thus, install approx. 153.2mm or more away

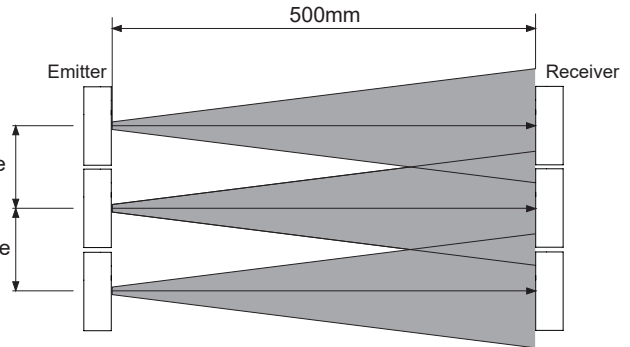

Thru-beam type: EX-13E□, EX-17E□ parallel deviation diagram (typical)

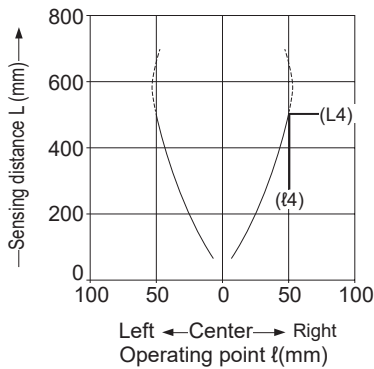

EX-13E□, EX-17E□: approx. 100mm or more

EX-13E□, EX-17E□: approx. 100mm or more

<Installation interval for EX-13E□, EX-17E□>
In case using at sensing distance ($L4$) 500mm, the operation point ($l4$) is approx. 50mm according to diagram above.

The installation interval is

Approx. $50\text{mm} \times 2 =$ approx. 100mm

Thus, install approx. 100mm or more away.

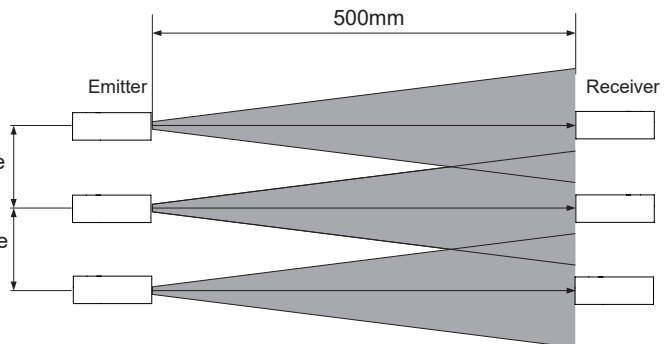

Thru-beam type: EX-19□, parallel deviation diagram (typical)

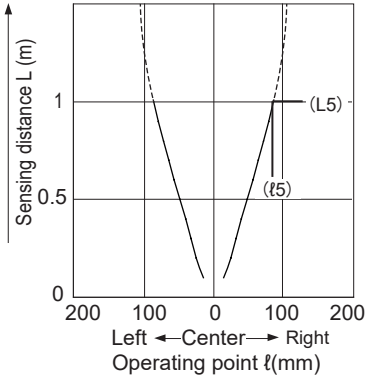

<Installation interval for EX-19□>

In case using at sensing distance (L5) 1m, the operation point (l5) is approx. 128.6mm according to diagram above.

The installation interval is
 Approx. 128.6mm × 2 = approx. 257.2mm
 Thus, install approx. 257.2 or more away.

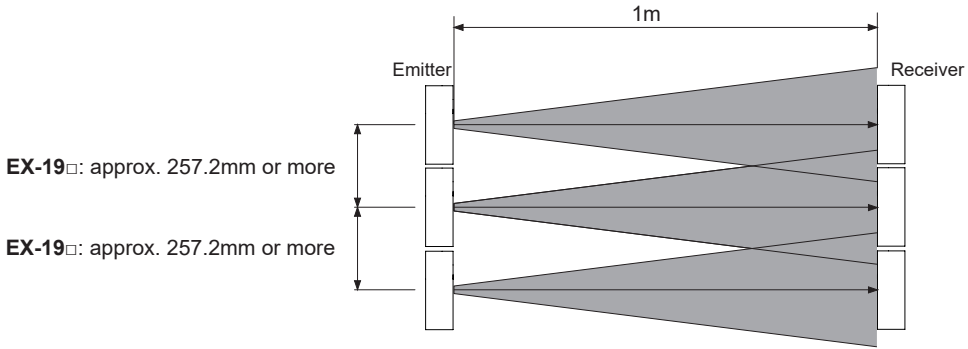

Thru-beam type: EX-19E□, parallel deviation diagram (typical)

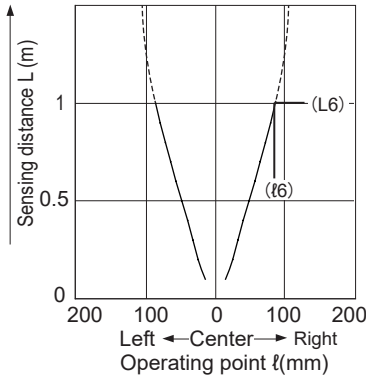

<Installation interval for EX-19E□>

In case using at sensing distance (L6) 1m, the operation point (l6) is approx. 71.1mm according to diagram above.

The installation interval is
 Approx. 71.1mm × 2 = approx. 142.2mm
 Thus, install approx. 142.2 or more away.

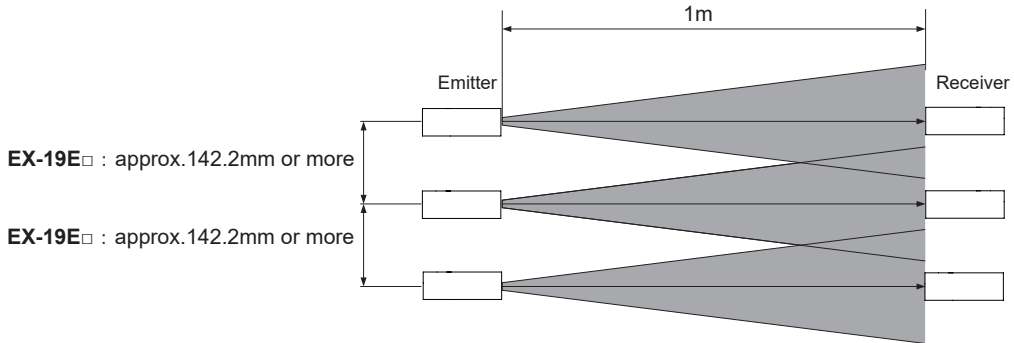

Thru-beam type: EX-11S□, parallel deviation diagram (typical)

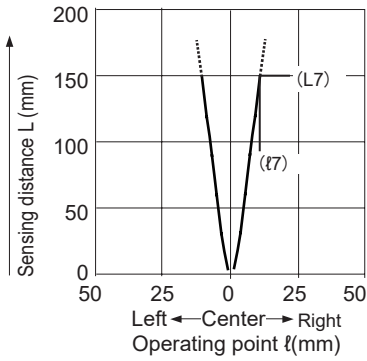

<Installation interval for EX-11S□>

In case using at sensing distance (L7) 150mm, the operation point (l7) is approx. 10.8mm according to diagram above.

The installation interval is

Approx. $10.8\text{mm} \times 2 = \text{approx. } 21.6\text{mm}$

Thus, install approx. 21.6 or more away.

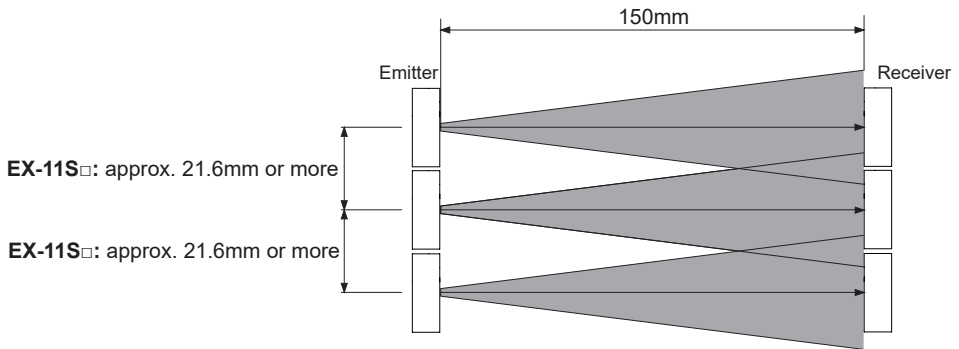

Thru-beam type: EX-11SE□, parallel deviation diagram (typical)

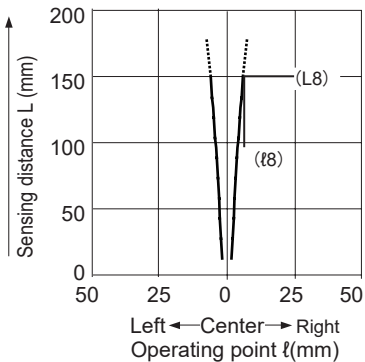

<Installation interval for EX-11SE□>

In case using at sensing distance (L8) 150mm, the operation point (l8) is approx. 6.2mm according to diagram above.

The installation interval is

Approx. $6.2\text{mm} \times 2 = \text{approx. } 12.4\text{mm}$

Thus, install approx. 12.4 or more away.

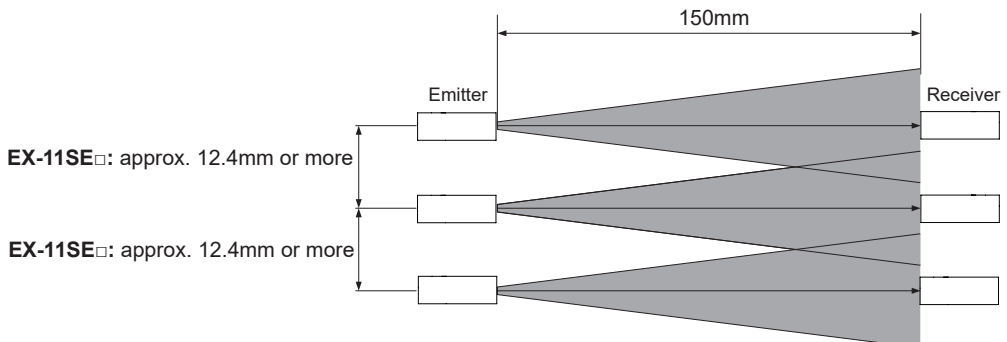

Thru-beam type: EX-13S□, parallel deviation diagram (typical)

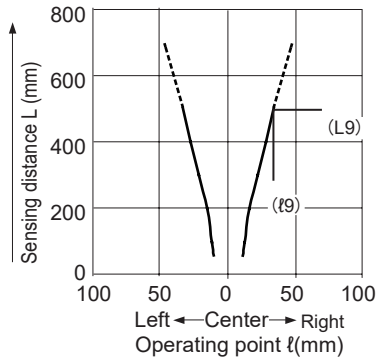

<Installation interval for **EX-13S**□>
 In case using at sensing distance (L9) 500mm, the operation point (l9) is approx. 37.1mm according to diagram above.
 The installation interval is
 Approx. 37.1mm × 2 = approx. 74.2mm
 Thus, install approx.74.2 or more away.

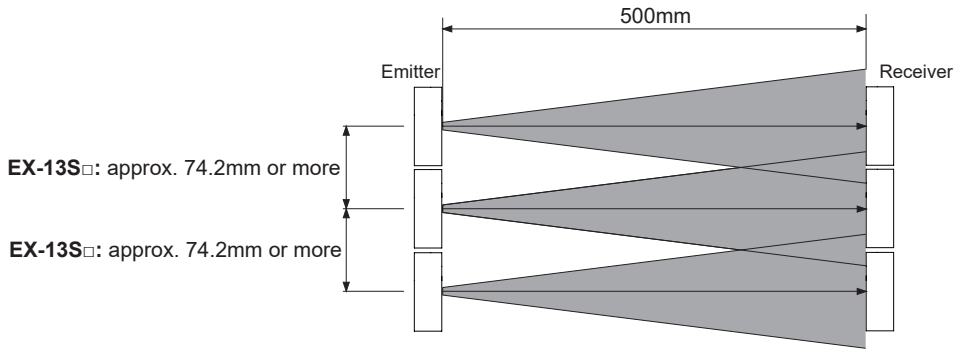

Thru-beam type: EX-13SE□, parallel deviation diagram (typical)

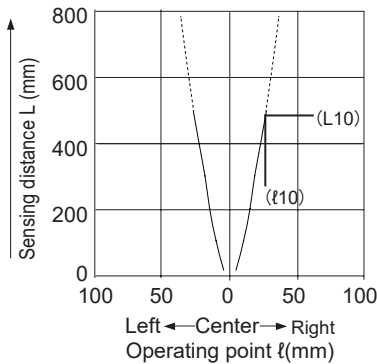

<Installation interval for **EX-13SE**□>
 In case using at sensing distance (L10) 500mm, the operation point (l10) is approx. 29.2mm according to diagram above.
 The installation interval is
 Approx. 29.2mm × 2 = approx. 58.4mm
 Thus, install approx.58.4 or more away.

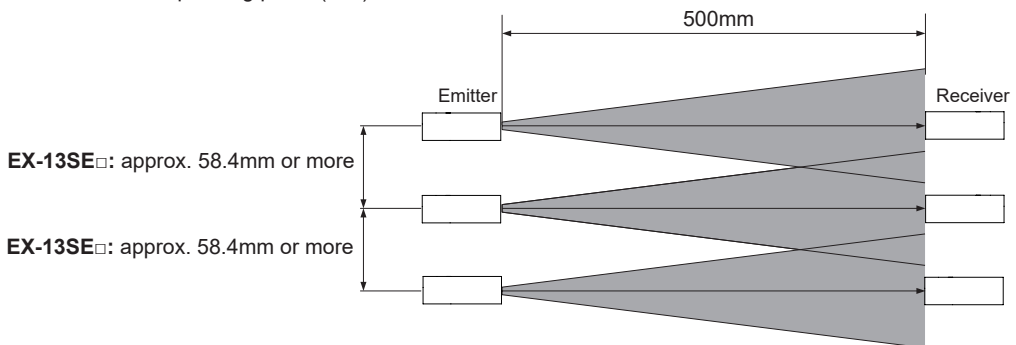

Thru-beam type: EX-19S□, parallel deviation diagram (typical)

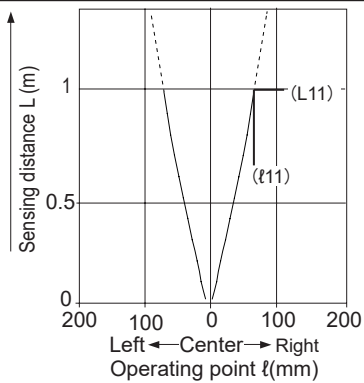

<Installation interval for EX-19S□>

In case using at sensing distance (L11) 1m, the operation point (l11) is approx. 65.4mm according to diagram above.

The installation interval is

Approx. 65.4mm × 2 = approx. 130.8mm

Thus, install approx.130.8 or more away.

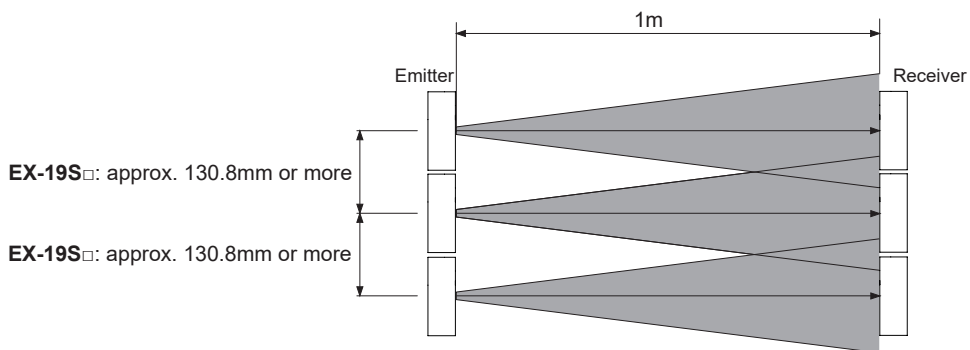

8. I/O Circuit Diagram

EX-11□, EX-13□, EX-19□, EX-14□

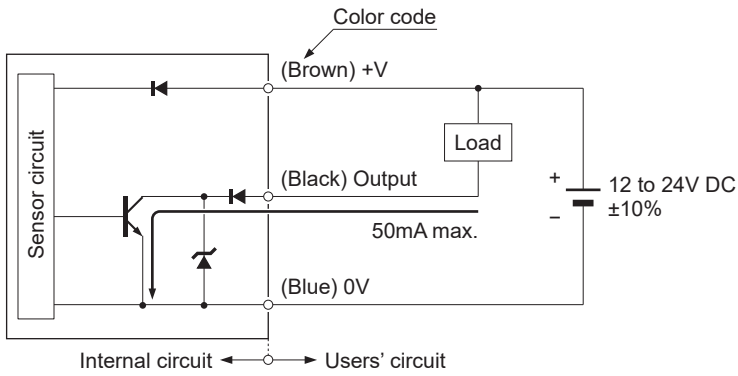

Note: The thru-beam type sensor emitter does not incorporate the output..

EX-11□-PN, EX-13□-PN, EX-19□-PN, EX-14□-PN

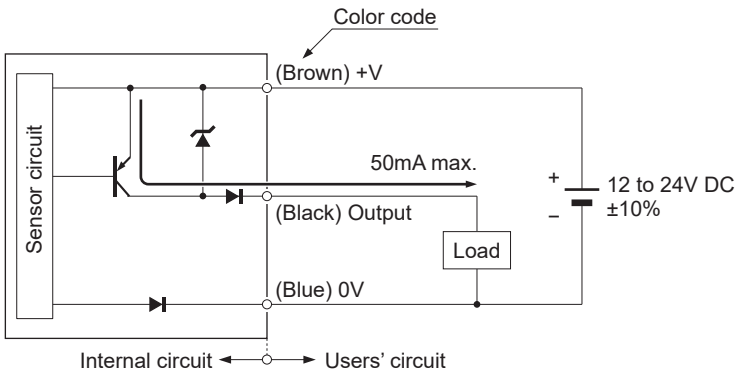

Note: The thru-beam type sensor emitter does not incorporate the output..

EX-15□, EX-17□

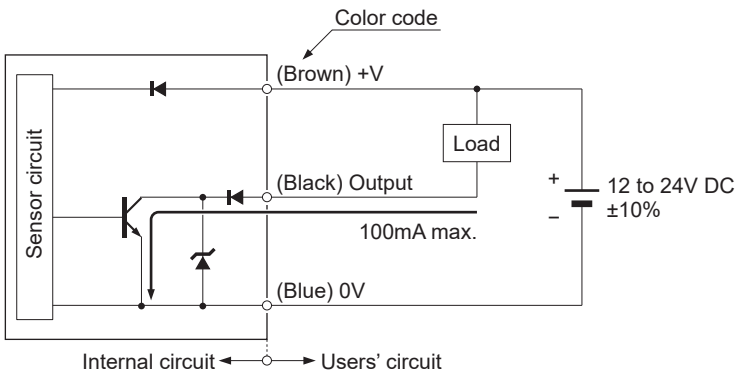

9. Stability Indicator

- The stability indicator (green) lights up when the incident light intensity has sufficient margin with respect to the operation level. Incident light intensity level is such that the stability indicator light up, stable sensing can be done without the light received operation and the light interrupted operation being affected by a change in ambient temperature or supply voltage.

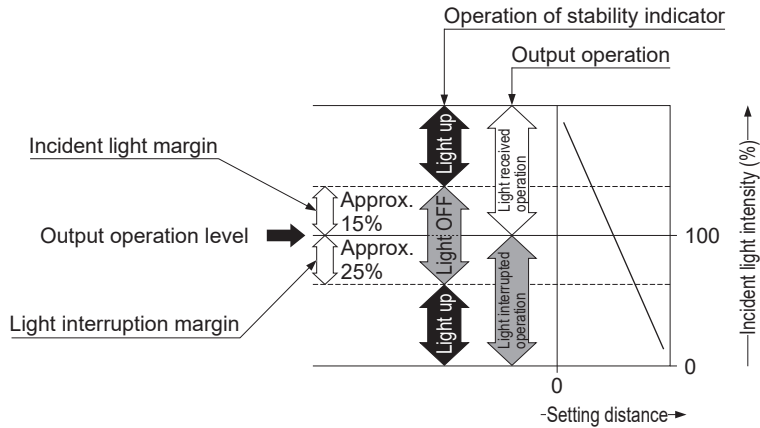

10. Beam alignment

Thru-beam type: EX-11□, EX-13□, EX-19□, EX-15□, EX-17□
EX-11S□, EX-13S□, EX-19S□

- Place the emitter and the receiver face to face along a straight line, move the emitter in the up, down, left and right directions, in order to determine the range of the light received condition with the help of the operation indicator (orange). Then, set the emitter at the center of this range.(Note 1)
- Similarly, adjust for up, down, left and right angular movement of the emitter.
- Further, perform the angular adjustment for the receiver also.
- Check that the stability indicator (green) lights up. (Note 2)

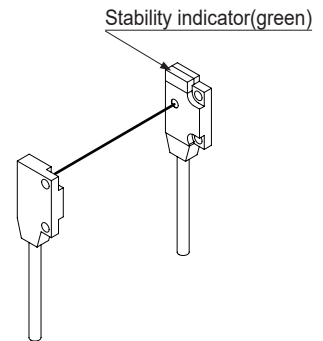

(Note1) : When using the narrow beam type EX-1□S□, if the beam axes are out of alignment, check to see if the emitter and the receiver are facing each other in a straight line.

(Note2) : In case of EX-15 / 17, adjust the beam axis after turn the operation mode switch to "L-ON". After it, switch the operation mode by adopting the operation.

11. Option

11-1 Slit Mask (optional)

- Apply the optional slit mask **OS-EX10-□** when detecting small objects or for increasing the accuracy of sensing position.
However, the sensing range is reduced when the slit mask is mounted.

| Type | Model No. | | Slit size | Sensing distance | | Minimal sensing object | |
|------|-------------|--------------------|-----------|----------------------|-----------------------|------------------------|-----------------------|
| | Slit | Sensor | | Applying on one side | Applying on both side | Applying on one side | Applying on both side |
| Slit | OS-EX10-12 | EX-19□ | ø1.2mm | 600mm | 400mm | ø2mm | ø1.2mm |
| | | EX-13□ | | 250mm | 200mm | ø2mm | ø1.2mm |
| | | EX-17□ | | 800mm | 500mm | ø2mm | ø1.5mm |
| | OS-EX10-15 | EX-19□ | ø1.5mm | 350mm | 300mm | ø2mm | ø1.5mm |
| | | EX-13□ | | 250mm | 200mm | ø2mm | ø1.2mm |
| | OS-EX10E-12 | EX-13E□ EX-17E□ | ø1.2mm | 250mm | 200mm | ø2mm | ø1.2mm |

OS-EX10-12
OS-EX10-15

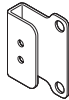

OS-EX10E-12



Mounting method

1. Insert the sensor into the slit.
2. Mount it to mounting plate. Make sure that the tightening torque is 0.2N·m or less.

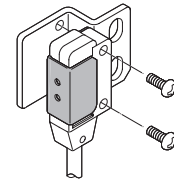

Tightening together with mounting plate

11-2 Sensor mounting bracket (optional)

- The sensor bracket is an object for standard-beam type. It cannot be used for narrow-beam type.

| Type | Model No. | Description |
|-------------------------|------------|---|
| Sensor mounting bracket | MS-EX10-1 | For front sensing type (Thru-beam type needs 2 sets.) Material: SPCC (Uni-chrome plated) • Two M2 (length 4mm) pan head screw are attached. |
| | MS-EX10-2 | For Side sensing type (Thru-beam type needs 2 sets.) Material: SPCC (Uni-chrome plated) • Two M2 (length 8mm) pan head screw are attached. |
| | MS-EX10-3 | L-form mounting bracket (Thru-beam type needs 2 sets.) Material: SPCC (Uni-chrome plated) • Two M2 (length 4mm) and Two M2 (length 8mm) pan head screw are attached. |
| | MS-EX10-11 | For front sensing type (Thru-beam type needs 2 sets.) Material: SUS304 • Two M2 (length 4mm) pan head screw are attached. |
| | MS-EX10-12 | For Side sensing type (Thru-beam type needs 2 sets.) Material: SUS304 • Two M2 (length 8mm) pan head screw are attached. |
| | MS-EX10-13 | L-form mounting bracket (Thru-beam type needs 2 sets.) Material: SUS304 • Two M2 (length 4mm) and Two M2 (length 8mm) pan head screw are attached. |

(Note) : Regarding the mounting image, refer to P11. Regarding the external dimensions, refer to P28 & 29.

12. Specifications

12-1 Standard-beam type

| Type | | Thru-beam type | | | | | | Convergent reflective (Diffused beam type) | |
|---|--------------|---|---------------|--|---|---|---------------|---|--|
| | | Front sensing | Side sensing | Front sensing | Side sensing | Front sensing | Side sensing | Front sensing | |
| Model No (Note 2) | Light-ON | EX-11A (-PN) | EX-11EA (-PN) | EX-13A (-PN) | EX-13EA (-PN) | EX-19A (-PN) | EX-19EA (-PN) | EX-14A (-PN) | |
| | Dark-ON | EX-11B (-PN) | EX-11EB (-PN) | EX-13B (-PN) | EX-13EB (-PN) | EX-19B (-PN) | EX-19EB (-PN) | EX-14B (-PN) | |
| Sensing range | | 150mm | | 500mm | | 1m | | 2 to 25mm (Note 3) (Center 10mm) | |
| Minimum sensing object | | ø1mm opaque object (Completely beam interrupted object) (Setting distance between emitter and receiver: 150mm) | | ø2mm opaque object (Completely beam interrupted object) (Setting distance between emitter and receiver: 500mm) | | ø2mm opaque object (Completely beam interrupted object) (Setting distance between emitter and receiver: 1m) | | ø0.1mm copper wire (Setting distance: 10mm) | |
| Hysteresis | | — | | | | | | 15 % or less of operation distance (Note 3) | |
| Repeatability (Perpendicular to sensing axis) | | 0.05mm or less | | | | | | 0.1mm or less | |
| Supply voltage | | 12 to 24V DC ±10% Ripple P-P 10% or less | | | | | | | |
| Current consumption | | Emitter: 10mA or less, Receiver: 10mA or less | | | | | | 13mA or less | |
| Output | | <NPN output type> NPN open-collector transistor <ul style="list-style-type: none"> • Maximum sink current: 50mA • Applied voltage: 30 V DC or less (between output and 0V) • Residual voltage: 2V or less (at 50mA sink current) 1V or less (at 16mA sink current) | | | <PNP output type> PNP open-collector transistor <ul style="list-style-type: none"> • Maximum source current: 50mA • Applied voltage: 30 V DC or less (between output and +V) • Residual voltage: 2V or less (at 50mA source current) 1V or less (at 16mA source current) | | | | |
| Short-circuit protection | | Incorporated | | | | | | | |
| Response time | | 0.5 ms or less | | | | | | | |
| Pollution degree | | 3 | | | | | | | |
| Protection | | IP67 (IEC) | | | | | | | |
| Ambient temperature | | -25 to +55°C (No dew condensation or icing allowed), Storage: -30 to +70°C | | | | | | | |
| Ambient humidity | | 35 to 85 % RH, Storage: 35 to 85% RH | | | | | | | |
| Operating altitude | | 2,000 m or less | | | | | | | |
| Emitting element | | Red LED (Peak emission wavelength : EX-19E=624nm, except EX-19E= 680nm, modulated) | | | | | | | |
| Material | | Enclosure: Polyallylate, Lens: Polyallylate | | | | | | | |
| Cable (Note 4) | | 0.1mm ² 3-core (thru-beam type emitter: 2-core) cabtyre cable, 2 m long | | | | | | | |
| Weight | Net weight | Emitter, receiver: Approx. 20 g each(-C5 type : Approx.50 g each) | | | | | | Approx.20g (-C5 type : Approx 50g) | |
| | Gross weight | Approx.50g(-C5 type : Approx.110 g) | | | | | | Approx.30g (-C5 type : Approx 60g) | |
| Accessories | | Mounting screws: 1 set, Instruction Manual | | | | | | | |

| Type | Thru-beam · with operation mode switch on bifurcation | | | |
|---|---|---------------|---|---------------|
| | Front sensing | Side sensing | Front sensing | Side sensing |
| Model No. (Note 2) | EX-15 (Note 5) | EX-15E | EX-17 | EX-17E |
| Sensing range | 150mm | | 500mm | |
| Minimum sensing object | ø1 mm opaque object (Completely beam interrupted object) (Setting distance between emitter and receiver: 150mm) | | ø2 mm opaque object (Completely beam interrupted object) (Setting distance between emitter and receiver: 500mm) | |
| Hysteresis | - | | | |
| Repeatability Perpendicular to sensing axis | 0.05mm or less | | | |
| Supply voltage | 12 to 24 V DC ±10 % Ripple P-P10 % or less | | | |
| Current consumption | 25mA or less | | | |
| Output | NPN open-collector transistor <ul style="list-style-type: none"> • Maximum sink current: 100 mA • Applied voltage: 30V DC or less (between output and 0 V) Residual voltage: 2V or less (at 100mA sink current) 1V or less (at 16mA sink current) | | | |
| Short-circuit protection | Incorporated | | | |
| Response time | 0.5ms or less | | | |
| Protection | IP67 (IEC) | | | |
| Ambient temperature | -25 to +55°C (No dew condensation or icing allowed), Storage: -30 to +70°C | | | |
| Ambient humidity | 35 to 85% RH, Storage: 35 to 85% RH | | | |
| Emitting element | Red LED (Peak emission wavelength: 680nm, modulated) | | | |
| Material | Enclosure: Polyallylate, Lens: Polyallylate, Bifurcation: Polyallylate | | | |
| Cable | 0.2 mm ² 3-core cabtyre cable, 2m long (beyond bifurcation; from emitter / receiver to bifurcation: 0.5m long) | | | |
| Wight | Net weight | 55g approx | | |
| | Gross weight | 80g approx. | | |
| Accessory | Mounting screws: 1 set, Adjusting screwdriver: 1 pc, Instruction Manual | | | |

12-2 Narrow-beam type

| Type | | Thru-beam type | | | | | |
|--|--------------|---|--|--|---|---|--|
| | | Front sensing | Side sensing | Front sensing | Side sensing | Front sensing | |
| Model No (Note 2) | Light-ON | EX-11SA (-PN) | EX-11SEA (-PN) | EX-13SA (-PN) | EX-13SEA (-PN) | EX-19SA (-PN) | |
| | Dark-ON | EX-11SB (-PN) | EX-11SEB (-PN) | EX-13SB (-PN) | EX-13SEB (-PN) | EX-19SB (-PN) | |
| Sensing range | | 150mm | | 500mm | | 1m | |
| Minimum sensing object | | ø0.5mm opaque object (Completely beam interrupted object) (Setting distance between emitter and receiver: 150mm) | ø1mm opaque object (Completely beam interrupted object) (Setting distance between emitter and receiver: 150mm) | ø1mm opaque object (Completely beam interrupted object) (Setting distance between emitter and receiver: 500mm) | ø2mm opaque object (Completely beam interrupted object) (Setting distance between emitter and receiver: 500mm) | ø2mm opaque object (Completely beam interrupted object) (Setting distance between emitter and receiver: 1m) | |
| Hysteresis | | — | | | | | |
| Repeatability (Perpendicular to sensing axis) | | 0.05mm or less | | | | | |
| Supply voltage | | 12 to 24V DC ±10% Ripple P-P 10% or less | | | | | |
| Current consumption | | Emitter: 10mA or less, Receiver: 10mA or less | | | | | |
| Output | | <NPN output type> NPN open-collector transistor ● Maximum sink current: 50mA ● Applied voltage: 30 V DC or less (between output and 0V) ● Residual voltage: 2V or less (at 50mA sink current) 1V or less (at 16mA sink current) | | | <PNP output type> PNP open-collector transistor ● Maximum source current: 50mA ● Applied voltage: 30 V DC or less (between output and +V) ● Residual voltage: 2V or less (at 50mA source current) 1V or less (at 16mA source current) | | |
| | | Short-circuit protection | | Incorporated | | | |
| Response time | | 0.5 ms or less | | | | | |
| Pollution degree | | 3 | | | | | |
| Protection | | IP67 (IEC) | | | | | |
| Ambient temperature | | -25 to +55°C (No dew condensation or icing allowed), Storage: -30 to +70°C | | | | | |
| Ambient humidity | | 35 to 85 % RH, Storage: 35 to 85% RH | | | | | |
| Operating altitude | | 2,000 m or less | | | | | |
| Emitting element | | Red LED (Peak emission wavelength : 650nm, modulated) | | | | | |
| Material | | Enclosure: Polyacrylate, Lens: Polyacrylate | | | | | |
| Cable (Note 4) | | 0.1mm ² 3-core (thru-beam type emitter: 2-core) cabtyre cable, 2 m long | | | | | |
| Weight | Net weight | Emitter, receiver: Approx. 20 g each | | | | | |
| | Gross weight | Approx. 50g | | | | | |
| Accessories | | Mounting screws: 1 set, Instruction Manual | | | | | |

- Notes:
- 1) Where measurement conditions have not been specified precisely, the conditions used were an ambient temperature of +23°C.
 - 2) The model No. with suffix "P" shown on the label affixed to the thru-beam type sensor is the emitter, "D" shown on the label is the receiver.
(EX) Emitter of **EX-11A**: **EX-11P**, Receiver of **EX-11A**: **EX-11AD**
Model Nos. having suffix "-R" are inflection resistant cable type. (except PNP output type, Narrow-beam type and Thru-beam type with operation mode switch on bifurcation **EX-15□** / **17□**)
(EX) **EX-11A** of inflection resistant cable type is "**EX-11A-R**"
Model Nos. having the suffix "-C5" are 5m cable length type. (except PNP output type, Narrow-beam type and inflection resistant cable type)
(EX) **EX-11A** of 5m cable length type is "**EX-11A-C5**"
 - 3) The sensing range and the hysteresis of convergent reflective type sensor are specified for white non-glossy paper (50 × 50 mm) as the object.
 - 4) The inflection resistant type (having suffix "-R" at end of model No.) has a 0.1mm² 3-core (thru-beam type emitter: 2-core) inflection resistant cabtyre cable, 2m long.
 - 5) Either Light-ON or Dark-ON can be selected by the operation mode switch (located on the bifurcation).

13. Dimensions

Thru-beam front sensing type: EX-11□, EX-13□, EX-19□, EX-11S□, EX-13S□, EX-19S□

<Emitter>

<Receiver>

(Unit: mm)

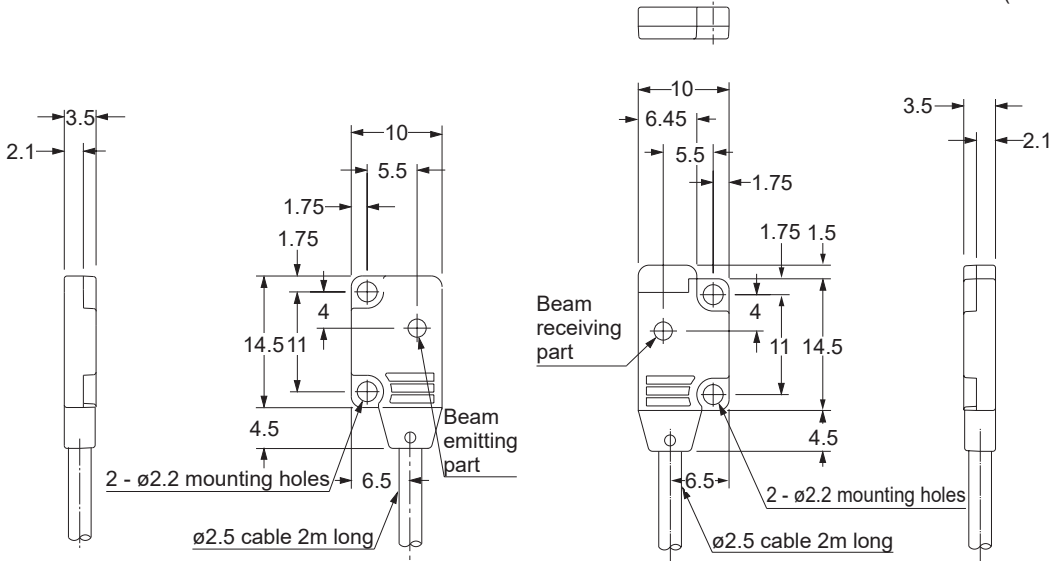

Thru-beam side sensing type: EX-11E□, EX-13E□, EX-19E□, EX-11SE□, EX-13SE□

<Emitter>

<Receiver>

(Unit: mm)

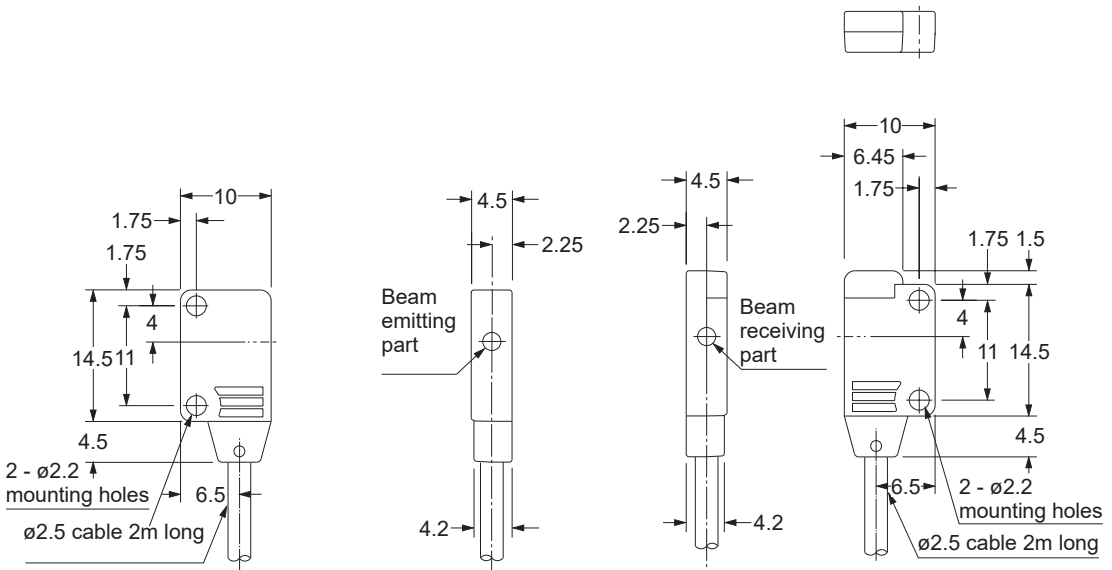

Thru-beam side sensing type with operation mode switch on bifurcation: EX-15E, EX-17E

<Emitter>

<Receiver>

(Unit: mm)

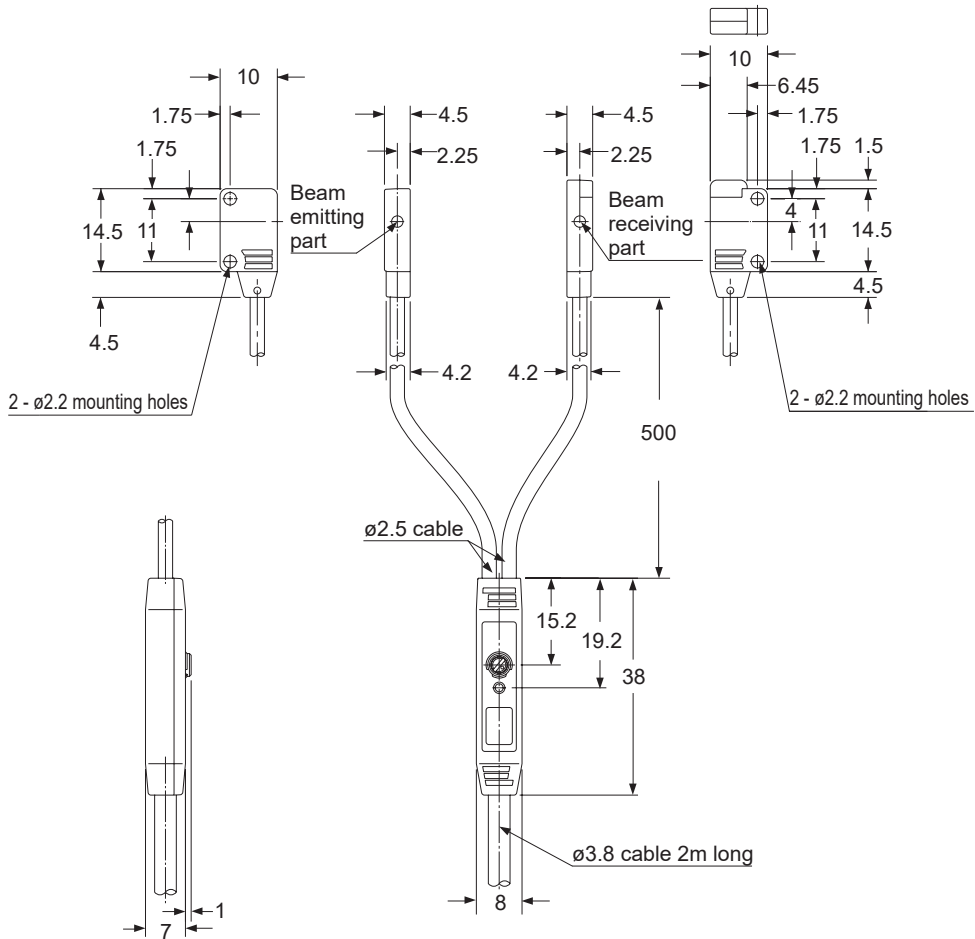

Convergent reflective: EX-14

(Unit: mm)

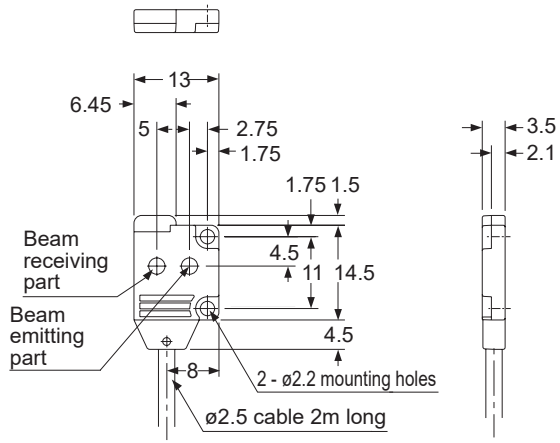

Mounting bracket: MS-EX10-1

(Unit: mm)

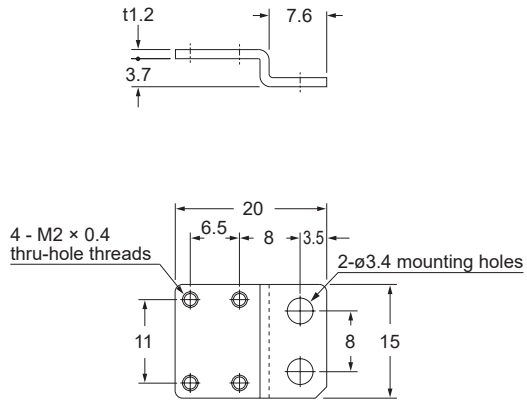

Mounting bracket: MS-EX10-2

(Unit: mm)

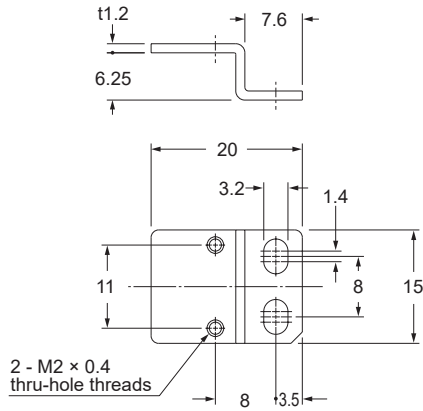

Mounting bracket: MS-EX10-3

(Unit: mm)

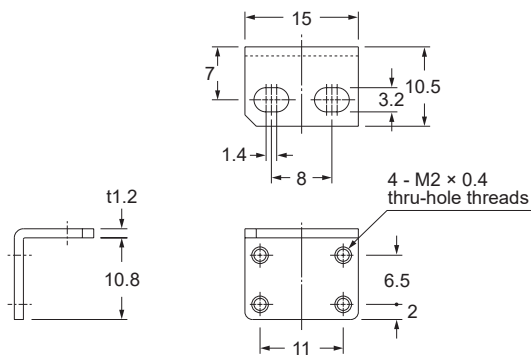

(Note):The sensor bracket is an object for satandard-beam type. It cannot be used for narrow-beam type.

Mounting bracket: MS-EX10-11

(Unit: mm)

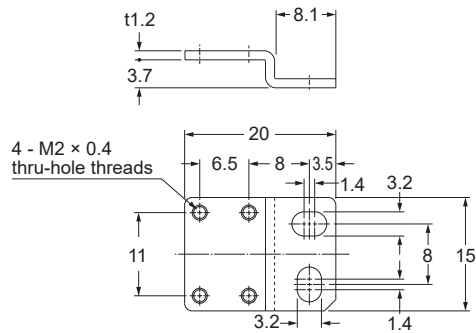

Mounting bracket: MS-EX10-12

(Unit: mm)

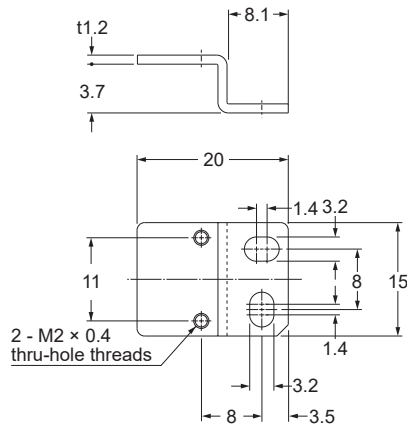

Mounting bracket: MS-EX10-13

(Unit: mm)

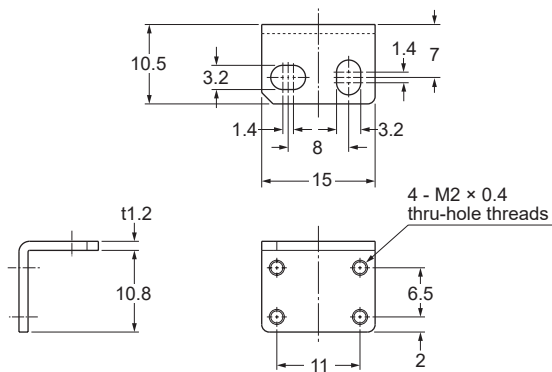

(Note):The sensor bracket is an object for satandard-beam type. It cannot be used for narrow-beam type.

14. When Using for Safety Applications

The EX-10 series (EX-11□ / EX-13□ / EX-19□ / EX-14□) conforms to Safety Category 1, PLc (ISO 13849-1:2015) and can be used as a detection device to indirectly protect the human body. Please read the following information for the correct usage of this product.

14-1 Safety Precautions Always observe

Specifications

- This device conforms to Safety Category 1, PLc (ISO 13849-1:2015) and can be used as a detection device to indirectly protect the human body.
- Before using this product, be sure to confirm the standards / regulations applied in the relevant nation and region.
- When using this product as part of a safety system, connect it to a safety controller that conforms to related standards.
- Parts or all of a human form may not be detected. This product must only be used for indirect protection methods.
- Objects within the deadband region or outside of the detection area, and transparent objects cannot be detected.

Power supply

- Be sure to use a SELV (Safety Extra Low Voltage) power supply unit with this device.

Wiring

- All electrical wiring should conform to the regional electrical regulations and laws. The wiring should be done by engineer(s) having the special electrical knowledge.
- Power supply and output wires for connecting to this device should be 0.3 mm² or greater with a total length of less than 30 m.

Operation

- In case this device does not perform properly, the operator should report this to the person in charge and stop the machine operation immediately. The machine must not be operated until correct performance of this device has been confirmed.

Other precautions

- This product has been developed and manufactured for industrial use only. This product must be disposed of using environmentally-friendly methods in accordance with applicable disposal and processing regulations of the country it is used in.

14-2 Safety Functions

This product has semiconductor output. Confirm the following before use.

- When using Light-ON:
Output is ON when light is detected, and OFF when there is absence of light.
- When using Light-OFF:
Output is OFF when light is detected, and ON when there is absence of light.

14-3 Safety Standards and Regulations

14-3-1 Parameters related to safety (Parameters described in ISO13849-1:2015)

- Safety side: Sensing (Thru-beam type: dark detected / Convergent reflective type: light detected)

| Name | Thru-beam type | | | | Convergent reflective type | | | |
|--|--|--------|------------|--------|----------------------------|--------|------------|--------|
| | NPN Output | | PNP Output | | NPN Output | | PNP Output | |
| | A Type | B Type | A Type | B Type | A Type | B Type | A Type | B Type |
| Safety side: Output status | OFF | ON | OFF | ON | ON | OFF | ON | OFF |
| MTTFd (Mean Time to Dangerous Failure) | 100 years or more | | | | | | | |
| DCavg (Average Diagnostic Coverage) | 0 | | | | | | | |
| CCF (Common Cause Failure) | 75 | | | | | | | |
| T1 (proof test interval) | 20 years | | | | | | | |
| Operating altitude | 2,000 m or less | | | | | | | |
| Response time | 0.5 ms or less | | | | | | | |
| Ambient operating temperature | -25 to +55°C (No condensation or icing), Storage: -30 to +70°C | | | | | | | |

- Safety side: Non-sensing (Thru-beam type: light detected / Convergent reflective type: non light detected)

| Name | Thru-beam type | | | | Convergent reflective type | | | |
|--|--|--------|------------|--------|----------------------------|--------|------------|--------|
| | NPN Output | | PNP Output | | NPN Output | | PNP Output | |
| | A Type | B Type | A Type | B Type | A Type | B Type | A Type | B Type |
| Safety side: Output status | ON | OFF | ON | OFF | OFF | ON | OFF | ON |
| MTTFd (Mean Time to Dangerous Failure) | 100 years or more | | | | | | | |
| DCavg (Average Diagnostic Coverage) | 0 | | | | | | | |
| CCF (Common Cause Failure) | 75 | | | | | | | |
| T1 (proof test interval) | 20 years | | | | | | | |
| Operating altitude | 2,000 m or less | | | | | | | |
| Response time | 0.5 ms or less | | | | | | | |
| Ambient operating temperature | -25 to +55°C (No condensation or icing), Storage: -30 to +70°C | | | | | | | |

14-3-2 Cautions when using in a ISO13849-1:2015 Category 3 PLd system

This product has been certified for use together with a Category 4 PLe safety controller / safety relay unit, which means it fulfills the requirements of Category 3 PLd. When using in this way, be sure to use two sensors in a sensor redundancy configuration.

To prevent loss of safety functionality due to accumulation of faults, build a control system with two redundant outputs which will stop the whole system when a discrepancy of output is detected.

Furthermore, before use, confirm that the calculated results of MTTFd and DCavg fulfill the requirements for Category 3, PLd.

■ Connection Example

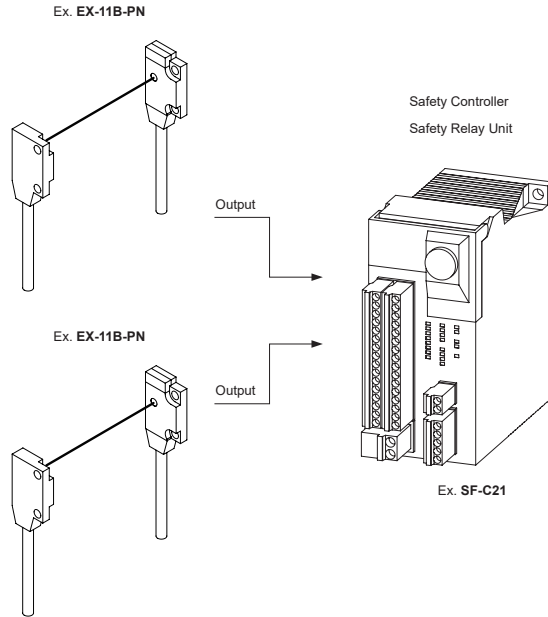

14-4 Maintenance

14-4-1 Daily Inspection

| | |
|---|--|
|  WARNING | |
| Before starting work, the worker should inspect the following items and verify that there are no abnormalities. Operating this device without performing the inspection or without removing the abnormal condition may cause death or serious injury. | |

Checklist (daily inspection)

| Check column | Inspection item |
|--------------------------|--|
| <input type="checkbox"/> | The output of this product should operate correctly as follows. (When using Light-ON) Output is ON when light is detected, and OFF when there is absence of light. (When using Light-OFF) Output is OFF when light is detected, and ON when there is absence of light. |
| <input type="checkbox"/> | No objects are added that create ambient or reflected light |
| <input type="checkbox"/> | No damage to safety fences or protective structures |

14-4-2 Regular (Bi-annual) Inspection

| | |
|--|--|
|  WARNING | |
| Inspect the following items every 6 months and verify that there are no abnormalities. Operating this device without performing the inspection or without removing the abnormal condition may cause death or serious injury. | |

Checklist (periodic inspection)

| Check column | Inspection item |
|--------------------------|--|
| <input type="checkbox"/> | The structure of the machine does not prevent any safety mechanisms from causing the machine to stop or to make an emergency stop. |
| <input type="checkbox"/> | No modification has been made in the machine control system that obstructs the safety mechanisms. |
| <input type="checkbox"/> | Wiring from this device has been performed correctly. |
| <input type="checkbox"/> | No screws or connectors related to the device are loose. |
| <input type="checkbox"/> | The current number of operation cycles (time) of parts (such as relays) with a limited service life is less than the number of service life cycles (time). |

14-4-3 Inspection Upon Product Replacement or Adjustment of the Beam Axis

| | |
|---|--|
|  WARNING | |
| Before starting work, the worker should inspect the following items and verify that there are no abnormalities. Operating this device without performing the inspection or without removing the abnormal condition may cause death or serious injury. | |

Inspection list (inspection upon product replacement/installation)

| Check column | Inspection item |
|--------------------------|--|
| <input type="checkbox"/> | Output from the device can be detected correctly |
| <input type="checkbox"/> | Wiring from this device has been performed correctly. |
| <input type="checkbox"/> | No screws or connectors related to the device are loose. |

14-5 Troubleshooting

Solutions to frequently encountered problems and errors are described below.

| Problem | Cause | Corrective action |
|----------------------------------|---|--|
| All operation indicators are OFF | Proper voltage is not supplied from the power supply. | Check the supplied voltage of the power supply. [Reference] "12. Specifications" on Page 21 |
| | There is a mistake in the wiring. | Check the wiring. [Reference] "8. I/O Circuit Diagram" on Page 18 |
| Output does not turn ON | The beam axis is not aligned. | Perform beam axis adjustment. [Reference] "10. Beam alignment" on Page 19 |

| Revision history | Revision date | Revision item |
|------------------|---------------|--|
| 1st edition | — | — |
| 2nd edition | — | — |
| 3rd edition | — | — |
| 4th edition | — | — |
| 5th edition | 2021/12 | Added descriptions of safety certification |
| 6th edition | 2024/4 | Company name change |

Panasonic Industry Co., Ltd.

1006, Oaza Kadoma, Kadoma-shi, Osaka 571-8506, Japan
<https://industry.panasonic.com/>

Please visit our website for inquiries and about our sales network.

Panasonic Industry Co., Ltd. 2024

April, 2024

WUME-EX10-6