

---

## REFERENCE SPECIFICATIONS

---

MODEL

Product Name: AC Servo Drive MINAS-LIQI series  
Part Number: MCDJT3230(REP.)

---

Issued on Mar.10, 2014  
( Revised on Sep. 5, 2014 )

Motor Business Unit, Appliances Company

Panasonic Corporation

7-1-1 Morofuku, Daito-City, Osaka 574-0044, Japan

Phone: (072) 871-1212

Fax: (072) 870-3151



Contents
----------

1. Scope .....	1
2. Model Designation Code .....	1
3. Product Line-up .....	2
4. General Specifications .....	3
5. Appearance and Part Names .....	4
6. Configuration of Connectors .....	6
6-1 USB Connector X1 .....	6
6-2 I/O Connector X2 .....	6
6-3 Encoder Connector X3 .....	13
6-4 Motor and Power Connector X4 .....	13
6-5 Front panel .....	14
7. Dimensions .....	15
8. Compliance with European EC Directive/ UL Standard .....	17
8-1 European EC directive .....	17
8-2 Peripheral Device Configuration .....	18
8-3 Compliance with UL Standard .....	19
9. Compliance with SEMI F47 Instantaneous Stop Standard .....	20
10. Safety precautions .....	21
11. Life and Warranty .....	25
11-1 Life Expectancy of the Driver .....	25
11-2 Standard life .....	25
11-3 Warranty Period .....	25
12. Others .....	26

Specifications by Model (Global Models)
---

## 1. Scope

These specifications relate to the servo driver for the AC servo system that is comprised of the AC servo motor manufactured and supplied by Motor Division, Panasonic Corporation, and the servo driver for driving this motor. This document of specifications defines products.

This product is for industrial equipment.

Don't use this product at general household.

<Notes>

(1) A part or all of the contents is not allowed to reprint, and not allowed to copy.

(2) For product improvement, the contents (specifications or software etc.) are subject to change Without prior notice

## 2. Model Designation Code

Notation of the machine designation code is as follows:

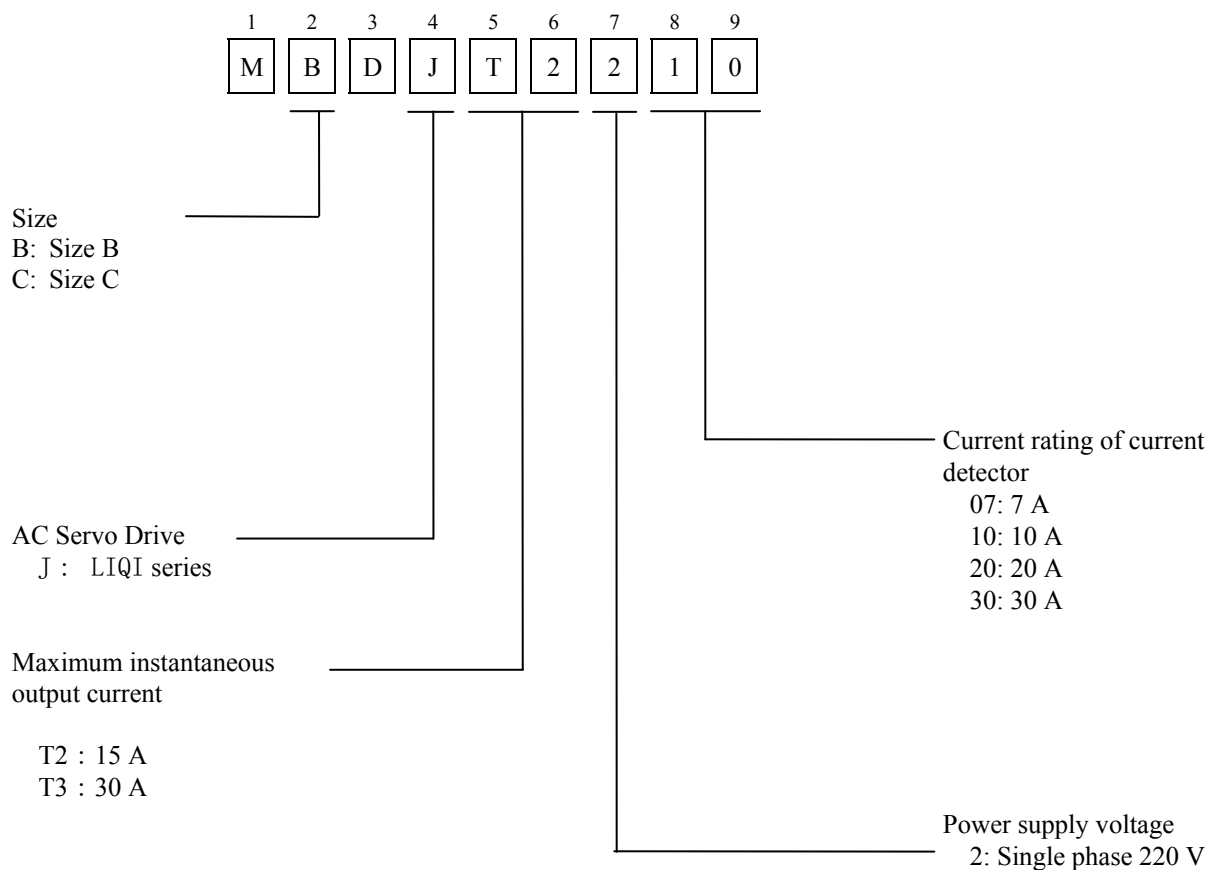

## 3. Product Line-up

Rated Voltage	Size	Part Number	Rated Output	Motor
1φAC 220-240 V	B	MBDJT2207	50 W	MSMD5AZJ1*
			100 W	MSMD012J1*
			200 W	MSMD022J1*
		MHMD022J1*		
		MBDJT2210	400 W	MSMD042J1*
				MHMD042J1*
	MHMJ042P1*			
	C	MCDJT3220	750 W	MSMD082J1*
				MHMD082J1*
				MHMJ082P1*
		MCDJT3230	1000 W	MSMD102J1*
				MHMD102J1*
		MCDJT3230	1000 W	MHMJ102P1*
	1200 W		MHMJ122P1*	

## 4. General Specifications

Basic Dimensions	Input power supply	AC 220 V line	Main circuit power	B	Single-phase 220 – 240 V <sup>+5%</sup> / <sub>-10%</sub> 50/60 Hz	
			Control circuit power	B	Single-phase 220 – 240 V <sup>+5%</sup> / <sub>-10%</sub> 50/60 Hz	
				C	Single-phase 220 – 240 V <sup>+5%</sup> / <sub>-10%</sub> 50/60 Hz	
			Insular resistance		Endure the conditions of 1500 V, 1Min, sensitive electric current 20 mA between primary-earth	
	Operation conditions	Temperature	Operation temperature: 0 – 50 degrees C (no condensation) Storage temperature: -20 – 65 degrees C (Max .temperature guarantee: 80 degrees C for 72 hours no condensation)			
		Humidity	Operation and storage humidity 20~85%RH or less (no condensation)			
		Height above the sea	Height above the sea level: 1,000 meters or less			
		Vibration	5.88 m/s <sup>2</sup> or less, 10 – 60 Hz (Continuous operation at resonance point is not allowed)			
	Control method		IGBT PWM method, sinusoidal drive			
	Encoder feedback		2500 P/r(resolution:10,000) 5-serial incremental encoder			
	Control signal	Input	Multi-function input 6, Function of each multi-function input is assigned by the parameter.			
		Output	Multi-function output 3 Function of each multi-function output is assigned by the parameter.			
	Pulse signal	Input	Opt coupler input 1 Both open collector and line driver interface can be connected.			
		Output	4 outputs Line driver output for Encoder pulses (A/B/Z signal) Open collector output also available for Z or EXZ signal			
	Communication	USB	USB interface to connect to computers for parameter setting or status monitoring.			
	Front Panel		2-digit 7-segment LED, 1-digit RSW			
	Regeneration		External regen resistor only			
Dynamic Brake		Built-in				
Control Mode		position control				

Function	Position Control	Digital Input	Deviation counter clear, Command pulse inhibition, Command scaling switch, Anti-vibration switch			
		Digital Output	In-position			
		Pulse Input	Max. Command Pulse Frequency	500 kpps		
			Command pulse input mode	Differential input. Selectable by parameter. ([1]Positive/Negative pulse [2]A/B quadrature [3]Pulse/Direction)		
			Command pulse Scaling (Electronic gear)	Applicable scaling ratio: 1/1000 – 1000 Any value of 1 – 10000 can be set for both numerator (which corresponds to encoder resolution) and denominator (which corresponds to command pulse resolution per motor revolution), but the combination has to be within the range shown above.		
			Smoothing Filter	1 <sup>st</sup> order filter or FIR filter selectable for command input		
		Anti-vibration Control	Available			
	Common	Auto-tuning	Operation command from the controller, with the inner workings command of the amplifier, according to identifying real-time load inertia, stiffness is setted automatically.			
		Scaling of feedback pulse	Any number of pulses can be set up. (maximum setting number is encoder resolution)			
		Protective Function	Hardware error	Overvoltage, undervoltage, over speed, overload, overheat, over current, encoder error, etc.		
			Software error	Following error fault, command pulse scaling error, EEPROM error, etc.		
Alarm data trace back	Tracing back of alarm data is available					

### 5. Appearance and Part Names

220 V Size B

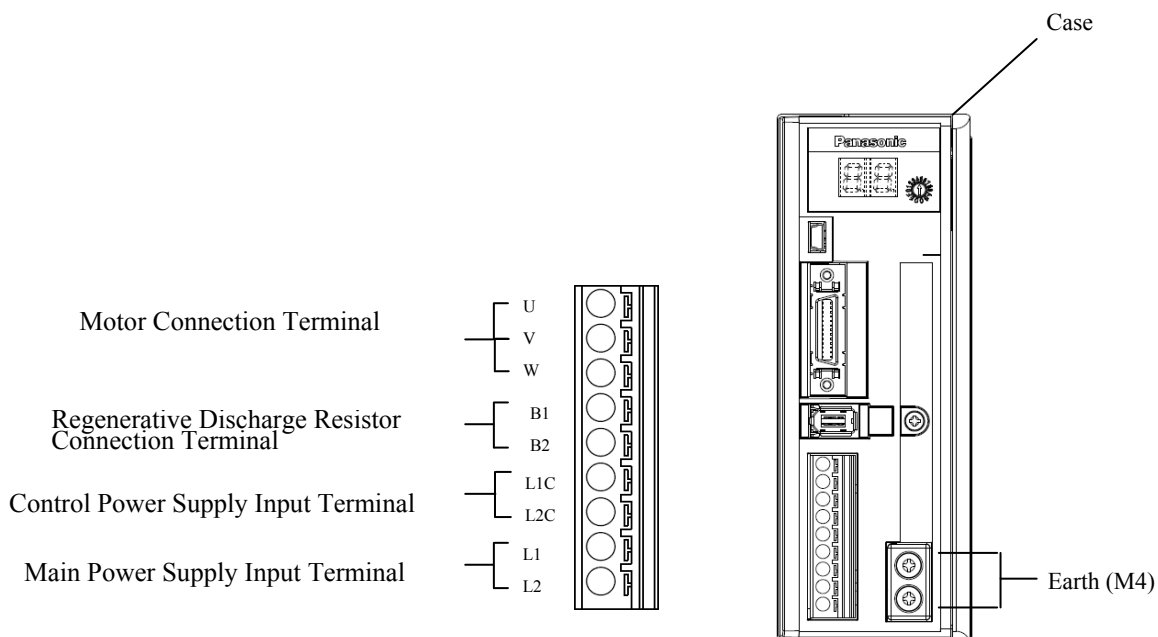
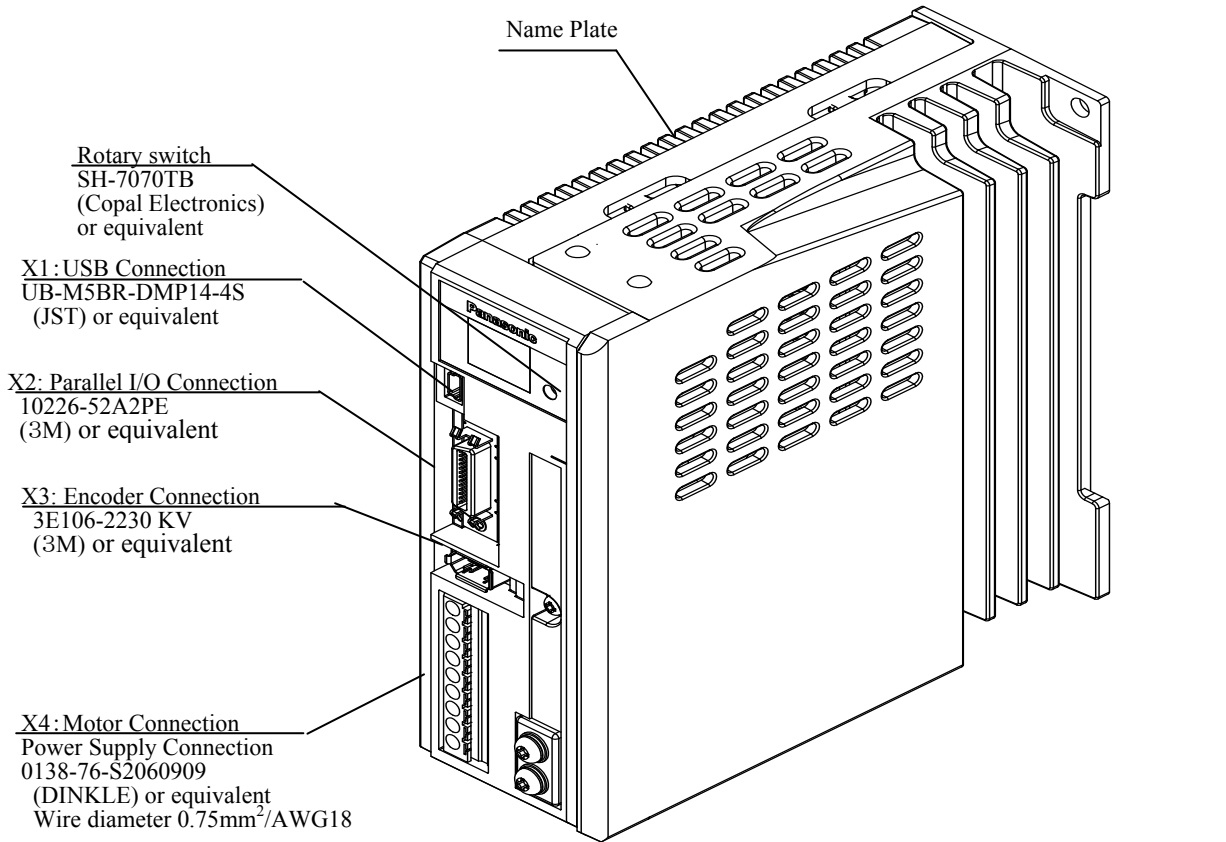

220 V Size C

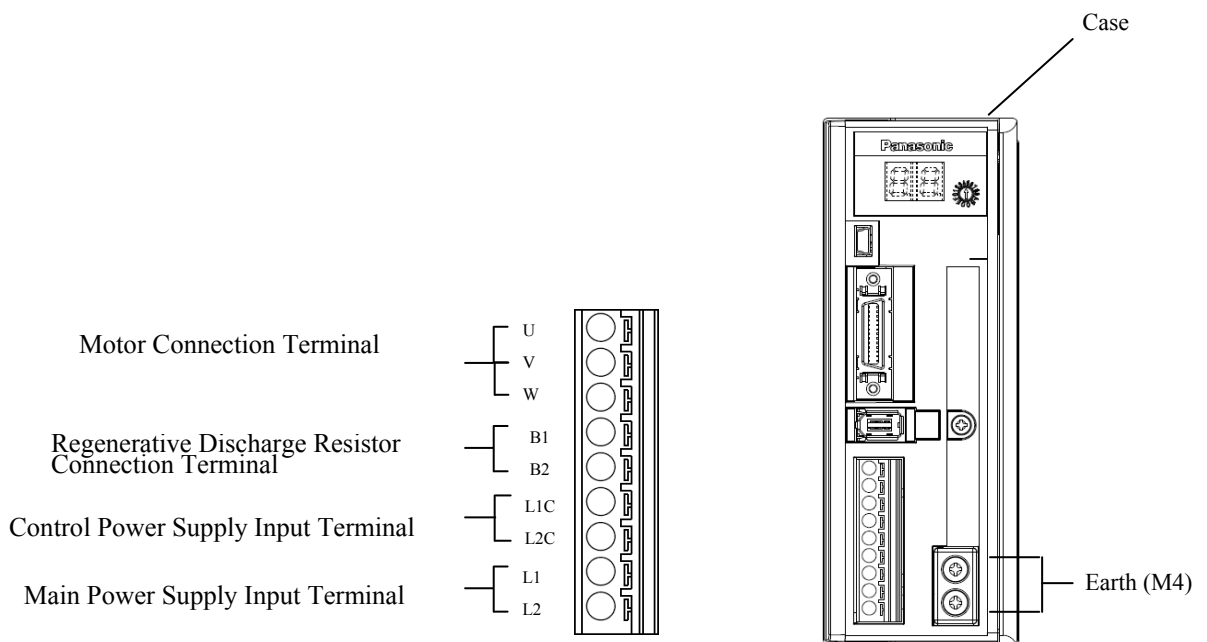
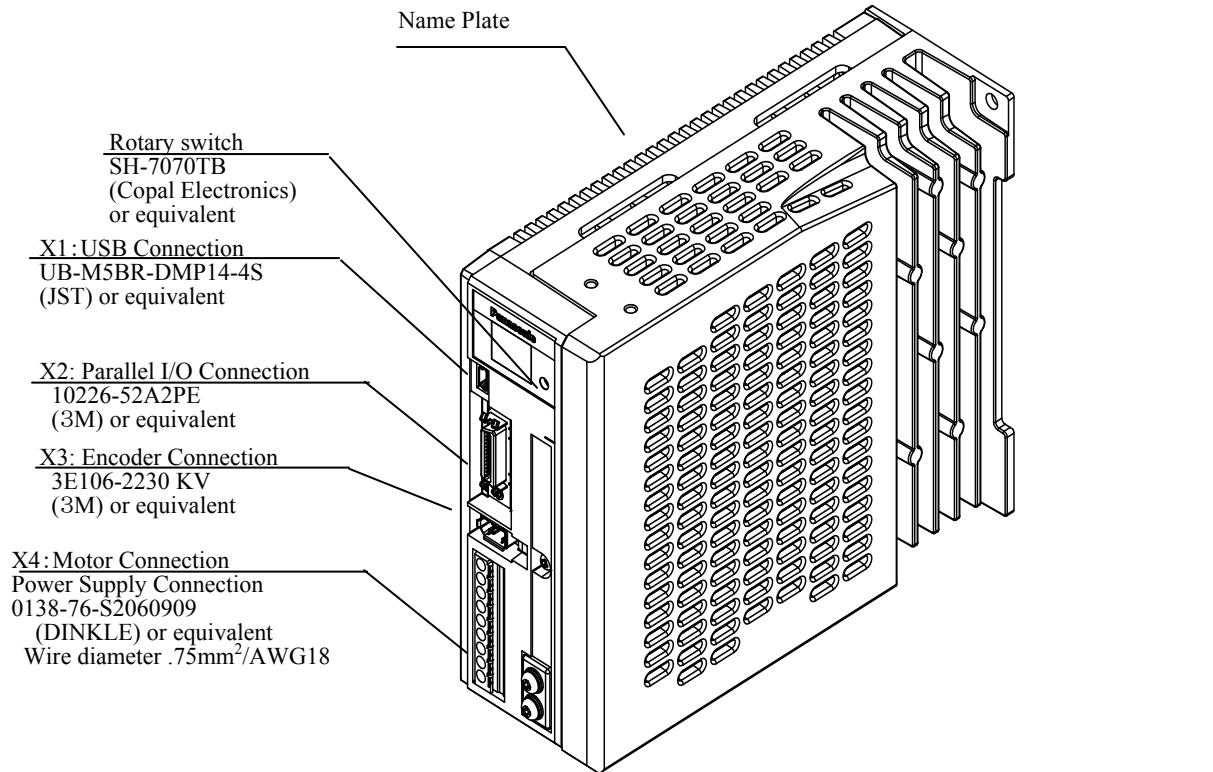



## 6. Configuration of Connectors

### 6-1 USB Connector X1

By connecting to a computer or a controller via USB interface, the following operations are available

- parameter reference / change
- parameter save / load
- monitoring of status
- checking alarm status or alarm history

Name	Symbol	Connector Pin No.	Description
USB signal	VBUS	1	Communicate with a computer or a controller
	D-	2	
	D+	3	
For manufacturer use	—	4	Do not connect
Signal ground	GND	5	Signal ground

### 6-2 I/O Connector X2

#### Common Digital Inputs

Name	Symbol	Description	Interface Circuit
Multi-function input 1	SI1	- The function changes according to the parameter settings. See below.	i-1
Multi-function input 2	SI2		
Multi-function input 3	SI3		
Multi-function input 4	SI4		
Multi-function input 5	SI5		
Multi-function input 6	SI6		

※Please initialization setting reference to function specifications.

## Functions allocatable to Multi-function inputs

Function	Symbol	Pin	Description
Servo ON	SRV-ON	2	-Tuning ON become the status of Servo on (Motor energized) and Shut off the energization to the motor.
Positive overtravel limit	POT	7	-This is Feed forward operation prohibition input Please connect as the connection point is open, when machine's movable part is over the travel range for feed forward. -In case that Input is OFF, the feed forward torque does not happen.
Negative overtravel limit	NOT	6	-This is Negative Direction operation prohibits. -Please connect as the connection point is open, when the machine's movable part is over the travel range for negative direction. -In case that this input is OFF, the negative direction torque does not happen.
Deviation counter clear	CL	4	-This is the deviation Counter Clear input (CL).
Anti-vibration switch 1	VS-SEL1	-	-This is vibration suppression switch input.
Anti-vibration switch 2	VS-SEL2	-	
Gain switch	GAIN	-	-This is gain switch input.
Alarm clear	A-CLR	3	-Alarm condition is released.
Command scaling switch	DIV1	-	- Switch the command pulse electric gear numerator.
	DIV2	-	By the combination of DIV1, DIV2, Maximum 4 switch is possible.
Command pulse inhibition	INH	5	-This is command pulse input prohibit input(INH).
	TL-SEL	-	
	E-STOP	-	

## ① Situations using the factory parameters

Factory-set state of the signal defined in the following table:

Input signal	corresponding parameters	Factory setting ():Decimal	Factory setting situation	
			Signal name	Theory
SI1 input	Pr4.00	00000003h (3)	SRV-ON	a type
SI2 input	Pr4.01	00000004h (4)	A-CLR	a type
SI3 input	Pr4.02	00000007h (7)	CL	a type
SI4 input	Pr4.03	00000088h (136)	INH	b type
SI5 input	Pr4.04	00000082h (130)	NOT	b type
SI6 input	Pr4.05	00000081h (129)	POT	b type

\* [-] That function is not assigned the status.

\* a type、b typeIs the state that the following:

a type: Signal input is COM- and open→Function invalid (OFF state)

Signal input is COM- and Connection→Function valid (ON state)

b type: Signal input is COM- and open→Function valid (ON state)

Signal input is COM- and Connection→Function invalid (OFF state)

The pattern book for the signal input ON / OFF function is defined as effective when ON, invalid is OFF.

## ② Changes in the distribution of the input signal using the Situations

Situations the input signal distribution changes, Follow the following parameters to change.

Classification	No.	Classification	Setting range	Flats	Function
4	00	SI1 Input selection	0~00FFFFFFh	-	SI1 Input only assigned setting: This parameter is used to set the hexadecimal representation of the benchmark. 000000**h 「**」 Part of the set the function designation. Please refer to the back of the function designation form. Function designation also includes theoretical setting. Cases) this pin is set to DIV1- a type wish to take the occasion, Please set 0000000Ch.
4	01	SI2 Input selection	0~00FFFFFFh	-	SI2 assigned function of the input setting. setting the same methods and Pr4.00.
4	02	SI3 Input selection	0~00FFFFFFh	-	SI3 assigned function of the input setting. setting the same methods and Pr4.00.
4	03	SI4 Input selection	0~00FFFFFFh	-	SI4 assigned function of the input setting. setting the same methods and Pr4.00.
4	04	SI5 Input selection	0~00FFFFFFh	-	SI5 assigned function of the input setting. setting the same methods and Pr4.00.
4	05	SI6 Input selection	0~00FFFFFFh	-	SI6 assigned function of the input setting. setting the same methods and Pr4.00.

Function of designations table

Signal Name	Symbol	Setpoint	
		a type	b type
Invalid	-	00h	Not set
Positive overtravel limit	POT	01h	81h
Negative overtravel limit	NOT	02h	82h
SUV-ON input	SRV-ON	03h	83h
Alarm clear	A-CLR	04h	Not set
(Setting prohibited)	-	05h	85h
Gain switch	GAIN	06h	86h
Deviation counter clear	CL	07h	Not set
Command pulse inhibition	INH	08h	88h
Torque limit switch input	TL-SEL	09h	89h
Anti-vibration switch 1	VS-SEL1	0Ah	8Ah
Anti-vibration switch 2	VS-SEL2	0Bh	8Bh
Command scaling switch 1	DIV1	0Ch	8Ch
Command scaling switch 2	DIV2	0Dh	8Dh
(Setting prohibited)	-	0Eh~13h	8Eh~93h
Alarm input force	E-STOP	14h	94h
(Setting prohibited)	-	15h	95h

## Note:

- Please do not setting table in a setting other than the setting value. The Situations has been set, Occur Err33.2 「I/F input function designation exception 1」, Err33.3 「I/F input function designation exception 2」. When there are set to table (Prohibition settings), the protection function does not effect, Since the function of the input signal will not work, set to invalid (00h).
- The same function can not be assigned to multiple signals. The Situations has been set, Occur Err33.0 「I/F input abnormal assigned repeat 1」, Err33.1 「I/F input abnormal assigned repeat 2」.
- Deviation counter clear (CL) Only with SI13 input distribution. If assigned to this other occasions, Occur Err33.6 「Clear the cumulative assigned abnormalities」

- Command pulse inhibit input (INH) input assigned can only be used by SI14.Err33.7 would occur if assigned to other occasions. 「Command pulse inhibit input」.
- The pin set to invalid control input will not affect the action.
- SRV-ON input signal (SRV-ON) must be distributed. The occasion not be distributed can not SRV-ON.

#### Input signals (command pulse train) and their functions

Suitable interface can be chosen from one kind of interface based on the specification of command pulses.

Pulse train interface with line driver

Name	Symbol	Connector Pin No.	Description	Circuit
Command pulse input2	PULS1	20	-Input terminal for the position command pulse. -Permissible max. input frequency is 500kpps at line driver input and 200kpps at open collector input.	Di-1
	PULS2	21		
Command direction input2	SIGN1	22		
	SIGN2	23		

#### Output signals (Common) and their functions

Name	Symbol	Description	Circuit
Multi-function output 1	SO1	- The function changes according to the parameter settings. See below.	o-1
Multi-function output 2	SO2		
Multi-function output 3	SO3		

※Please refer to setting pattern initialization function.

#### Functions allocatable to Multi-function outputs

Name	Symbol	Connector Pin No.	Description
Servo output alarm	ALM	8	- Digital output to indicate alarm status.
Servo output delay	S-RDY	10	- Said drive signal to the output power status.
Motor holding break release	BRK-OFF	-	- Digital output to provide the timing signal to control the motor holding brake.
Zero speed	ZSP	-	- Digital output to indicate the zero speed status.
Torque limited	TLC	-	- Digital output to indicate the torque is limited.
In-position	INP	9	- Digital output to indicate the in-position status.( INP)
In-position 2	INP2	-	- Digital output to indicate the in-position status.( INP2)
Warning output 1	WARN1	-	- Digital output to indicate the warning output signal status. Set by Pr4.31 "warning output 1"
Warning output 2	WARN2	-	- Digital output to indicate the warning output signal status. Set by Pr4.32 "warning output 2"
position command output	P-CMD	-	- Digital output to indicate position command
Alarm attribute output	ALM-ATB	-	- Digital output to Alarm which can be cleared.
Main Power output	P-ON	-	- Digital output to voltage which exceed to the level voltage of Servo on.

## ① Occasion to use the factory settings

Factory-set state of said signal distribution is as follows.

Output signal	The corresponding parameters	Factory settings ():10 hex	Factory settings
			Signal Name
SO1 Output	Pr4.10	0000001h (1)	ALM
SO2 Output	Pr4.11	0000004h (4)	INP
SO3 Output	Pr4.12	0000002h (2)	S-RDY

## ② Changes in the distribution of the output signal using the occasion

Distribution of the output signal changes of use, please follow the following parameters to change.

Classification	No.	Parameter name	Setting range	Flats	Function
4	10	SI1 Input selection	0~00FFFFFFh	-	SO1 Distribution of the output set of skills. This parameter is the hexadecimal representation of the benchmark set. 000000**h [**] Part of the set the function designation. Please refer to back of Schedule function designations.
4	11	SI2 Input selection	0~00FFFFFFh	-	SO2 Distribution of the output set of skills. Set the same methods and Pr4.00.
4	12	SI3 Input selection	0~00FFFFFFh	-	SO3 Distribution of the output set of skills. Set the same methods and Pr4.00.

## Function of designations table

Signal Name	Symbol	Setpoint
		a type
Invalid	-	00h
Servo output alarm	ALM	01h
Servo output delay	S-RDY	02h
Motor holding break release	BRK-OFF	03h
In-position	INP	04h
(Setting prohibited)	-	05h
Torque limiting signal output	TLC	06h
Zero speed detected signal	ZSP	07h
(Setting prohibited)	-	08h
Warning output 1	WARN1	09h
Warning output 2	WARN2	0Ah
position command output	P-CMD	0Bh
In-position 2	INP2	0Ch
(Setting prohibited)	-	0Dh
Alarm attribute output	ALM-ATB	0Eh
(Setting prohibited)	-	0Fh
Main Power output	P-ON	10h

## Note:

- Output of signal can be assigned the same Function of complex signals.
  - Setting an invalid control outputs pin, General state of the output transistor will turn off.
  - Please do not set the table Setpoint the value of outside.
- If set, will happen Err33.4 [I/F Output of Function of designations unusual 1] . Another table is (setting disabled), set to protect the Function of, while not action, but the Output of becomes unstable.

## Output signals (command pulse train) and their functions

Name	Symbol	Connector pin No.	Description	Circuit
Absolute value of the output phase A	OA+	13	Sub-week treatment, the encoder signals and the external encoder signal (A · B · Z phase) differential output. (Equivalent to RS422) <ul style="list-style-type: none"> <li>• Weeks than in the sub-set parameters.</li> </ul> Long-term driver of output circuit connected to the signal, Non-insulated. <ul style="list-style-type: none"> <li>• Maximum number of Output of frequency is 4 Mpps (4 times after).</li> </ul>	Do-1
	OA-	14		
B-phase outputs	OB+	15		
	OB-	16		
Z-phase outputs	OZ+	17		
	OZ-	18		
Z-phase outputs	CZ	19	<ul style="list-style-type: none"> <li>• the output of Z-open-circuit.</li> <li>• Long-term driver of output circuit connected to the signal of emitter and ground, Non-insulated.</li> </ul>	Do-2

## Others

Name	Symbol	Connector Pin No.	Description	Circuit
Control signal power supply	COM+	1	<ul style="list-style-type: none"> <li>• External DC power(12~24 V) supply with the + connection</li> <li>• Please use the 12 V ± 5%~24 V ± 5% power supply</li> </ul>	—
	COM-	11	<ul style="list-style-type: none"> <li>• External DC power(12~24V) supply with the - connection</li> <li>• Use the power capacity of the different composition of input and output circuit</li> <li>Recommended for more than 0.5A</li> </ul>	—
Frame ground	FG	Shell 26	<ul style="list-style-type: none"> <li>• Internally connected to the earth terminal.</li> </ul>	—
Signal ground	SG	12	<ul style="list-style-type: none"> <li>• Signal ground</li> <li>• Internally insulated from the control signal power supply (COM-).</li> </ul>	—
Reserved	—	24/25	<ul style="list-style-type: none"> <li>• Don't connect, please</li> </ul>	—

Input and output signal interface

i-1

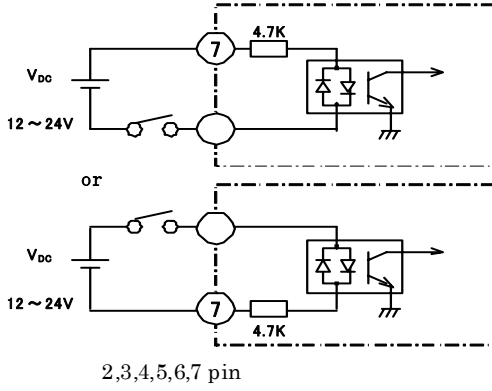

o-1

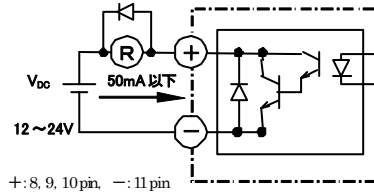

Note) If you want to directly driver a relay, In parallel with the relay.  
Please install the diode in the direction shown above.  
 $V_{CEsat}=1.2V$

Di-1

For open collector

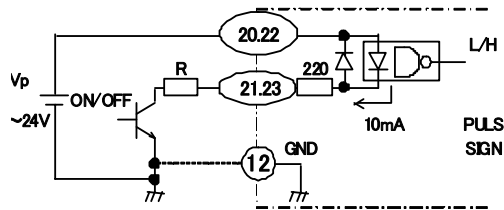

Do-1

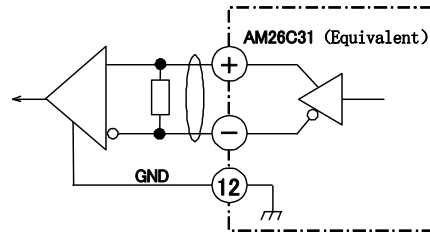

+: 13,15,17 pin, -: 14,16,18 pin

Do-2

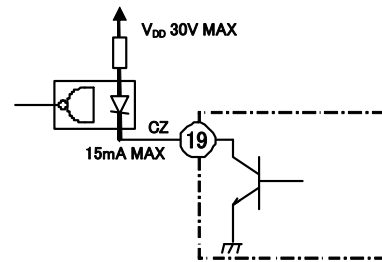

6-3 Encoder Connector X3

Description	Connector Pin No.	Symbol
Encoder power supply output	1	E5V
	2	E0V (*Remark 1)
—	3	—
	4	—
Encoder Signal input/out put (Serial Signal)	5	PS
	6	/PS
Frame ground	shell	FG

\* Remark 1) The E0V of the encoder power supply output is connected with the control circuit ground of the connector.

6-4 Motor and Power Connector X4

Size B,C of 220 V System

	Terminal Symbol	Terminal Name	Description			
X4	U(red)	Motor connection	Connect each phase of the motor winding. U: U phase    V: V phase    W: W phase			
	V(gray)					
	W(black)					
	B1(gray)	Regen. resistor connection	If the drive gets over regeneration alarm, connect an external regen resistor (prepared by customer) between B1 and B2.			
	B2(gray)					
	L1C(red)	Control power supply input	220 V	Single phase 220~240 V	+ 5%	, 50/60 Hz input
	L2C(red)				- 10%	
	L1(black)	Main power supply input	220 V	Single phase 220~240 V	+ 5%	, 50/60 Hz input
L2(black)	- 10%					
		Earth	Earth terminal for grounding.			

Please select the ferrule length between 12 mm ~ 15 mm. Short ferrule pins can not be fixed during the insertion. Ferrule pin of DNH4 -112 made in DINKEL (4 mm diameter) is recommended.

※Tighten the fixing screws to the case at screw torque of 0.4~0.6 N·m or less.

※While not use the ferrule pin, ensure that all the cables into the connector, to avoid short circuits.



## 6-5 Front panel

## ■ Configuration of Front panel

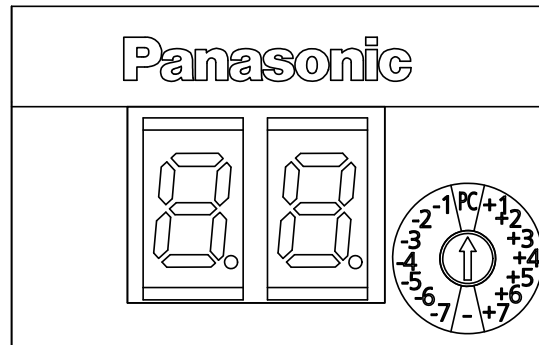

## ■ Rotary switch(RSW)

By manipulating the RSW, Pr.0.03(selection of stiffness at real-time auto-gain tuning) was corrected by setting the RSW, and can be changed from the front panel gain control.

RSW setting	The stiffness correction	Example) Pr0. 03=8		Parameter Pr0.03 is changed
		Stiffness after correction	LED Display	
PC	$\pm 0$	8	Pc	Possible
+1	+1	9	9	Impossible
+2	+2	10	10	
+3	+3	11	11	
+4	+4	12	12	
+5	+5	13	13	
+6	+6	14	14	
+7	+7	15	15	
-	$\pm 0$	8	8	
-7	-7	1	1	
-6	-6	2	2	
-5	-5	3	3	
-4	-4	4	4	
-3	-3	5	5	
-2	-2	6	6	
-1	-1	7	7	

## ■ Operation method

When power is turned on after the show check pattern, and displays the following normal.  
If you operate the RSW, LED displays a real-time stiffness after adjustment for the RSW.  
However, in the event that an alarm occurs, alarm codes (main and sub) display.

- During warnings occur, the display will flash slowly.
- When an error occurs, the display switches to cause an error with flashing numbers.
- Rotary Switches is a length of 4mm and a width of 1mm ,so flat-blade screwdriver to set the rotary switch that is less than 4mm in width and thickness of 1mm or less.

7. Dimensions

External Dimension Size B

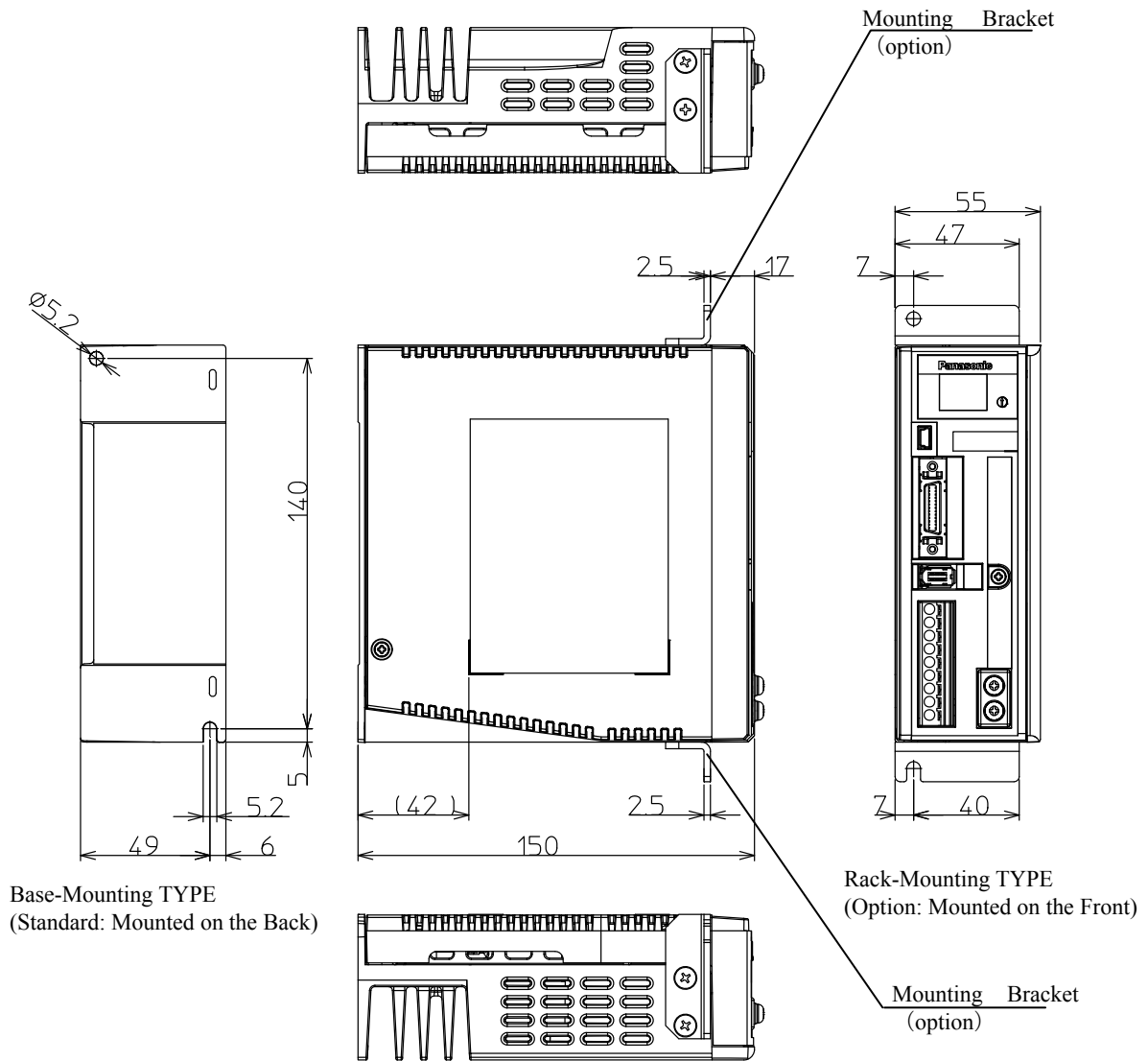

Mounting Bracket (option) Code

	Code
B Type	DV0PM20028

External Dimension Size C

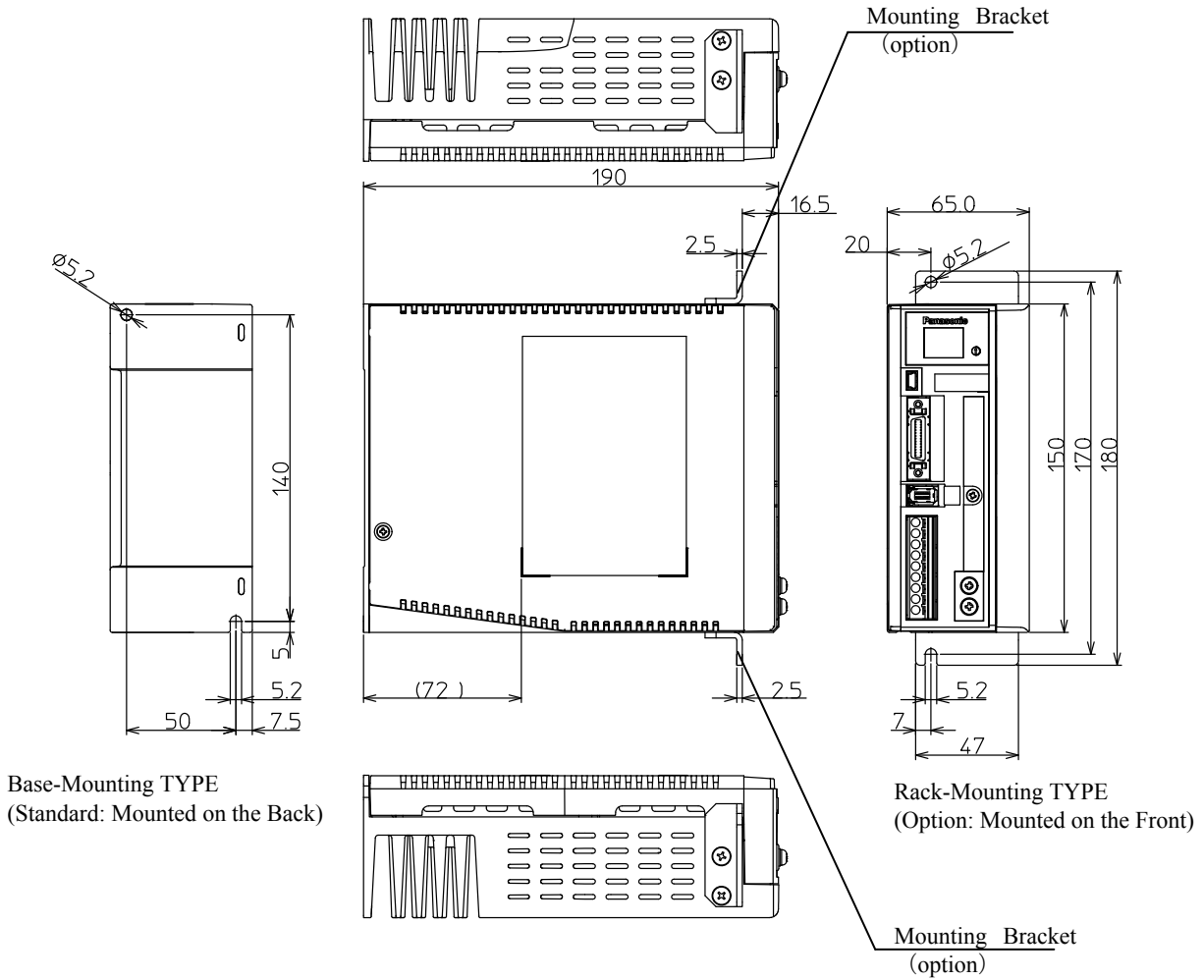

Mounting Bracket (option) Code

	Code
C Type	DV0PM20028

## 8. Compliance with European EC Directive/ UL Standard

### 8-1 European EC directive

European EC directive is applied to all electronic products that are exported to EU, have the inherent functions, and are directly sold to the consuming public. These products are obliged to be compliant with the unified EU safety standard and paste the CE marking indicating the compliance to the products.

Our products, in order to make it easy for the embedded equipments and devices to be compliant with EC directive, provide the compliance with the standards associated with low voltage directive.

#### 8-1-1 Compliance with EMC Directive

Our servo system determines the model (conditions) such as the installed distance and the wiring of the servo amplifier and the servomotor and makes the model compliant with the standards associated with EMC directive. When equipments and devices are embedded in practice, wiring and grounding conditions, etc. may be not the same as the model. Thus, it is necessary to measure how the final equipments and devices where the servo amplifier and the servo motor are embedded are compliant (especially unnecessary radiation noise, noise terminal voltage) with EMC directive.

#### 8-1-2 Conforming Standards



		Amplifier	Motor
European EC directive	EMC directive	EN55011:2009/A1:2010 (Group1, Class A) EN61000-6-2:2005 EN61800-3:2004/A1:2012 (Category C3, second environment)	
	Low voltage directive	EN61800-5-1	IEC60034-1 IEC60034-5
UL standard		UL508C (File No. E164620)	UL1004-1 (File No.E32768: 750W or under (200V)) UL1004 (FileNo.E32768: 750W or under (400V), from 1.0kW to 1.2kW)
CSA standard		C22. 2 No. 14	C22. 2 No. 100

- IEC : International Electrotechnical Commission  
 EN : Europaischen Norman  
 EMC : Electromagnetic Compatibility  
 UL : Under writers Laboratoris  
 CSA : Canadian Standards Association

## 8-2 Peripheral Device Configuration

### 8-2-1 Installation Environment

Use the servo amplifier under the environment of pollution level 2 or 1 defined in IEC60664-1.

(Example: Installed in the IP54 control panel.)

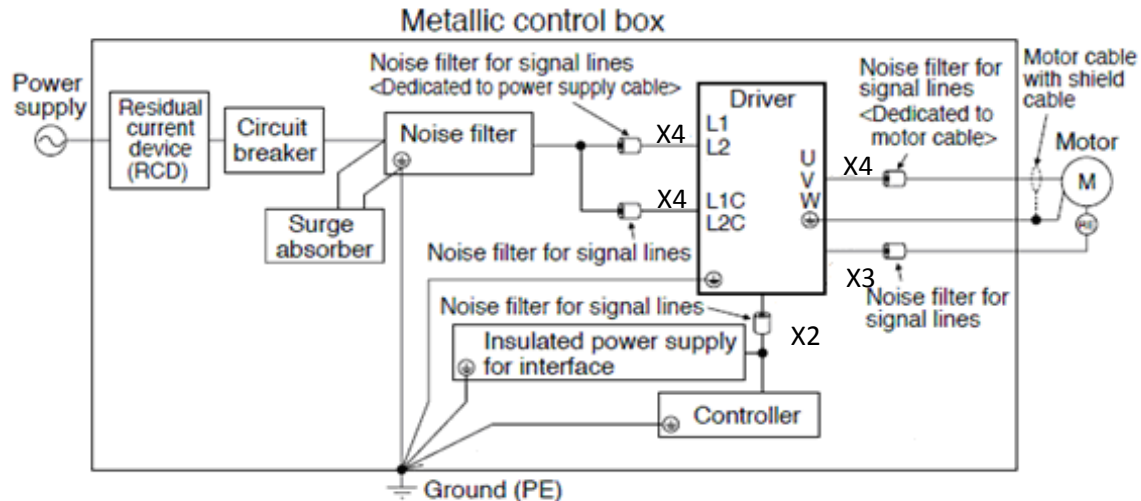

### 8-2-2 Power Supply

200 V system : Single 220 V – 240 V  $\begin{matrix} +5\% \\ -10\% \end{matrix}$  50/60 Hz

- (1) Use it under the environment of overvoltage category II defined in IEC60664-1.
- (2) As for the interface power supply, use the CE marking conforming product or the 12-24 VDC power supply of insulation type compliant with EN standard (EN60950).

### 8-2-3 Circuit Breaker

Make sure to connect a circuit breaker compliant with IEC standard and UL certification

(marked with LISTED  $\text{UL}$ ) between the power supply and the noise filter.

Integral solid state short circuit protection does not provide branch circuit protection. Branch circuit protection must be provided in accordance with the National Electrical Code and any additional local codes.

### 8-2-4 Noise Filter

To install one noise filter as a whole in the power unit when multiple servo amplifiers are used, consult the noise filter manufacturer.

### 8-2-5 Surge Absorber

Install the surge absorber in the primary side of the noise filter.

Please!

To carry out a pressure test of equipments and devices, make sure to detach the surge absorber. Otherwise, the surge absorber can be damaged.

### 8-2-6 Noise Filter for Signal Line

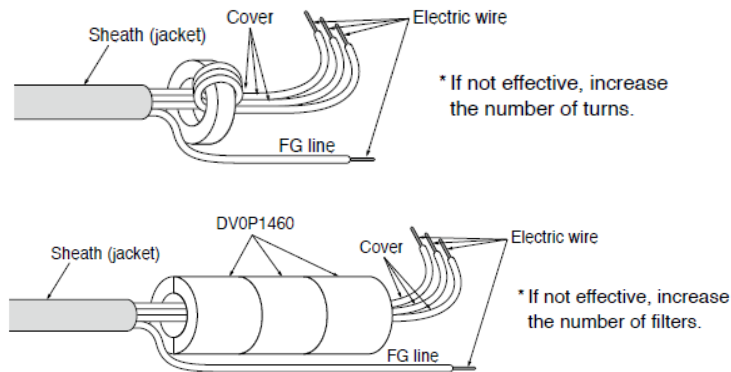

Install the noise filters for signal lines in all cables (power supply, motor, encoder, and interface cables), and the reactor in power supply cable.



Recommended Surge absorber, Noise filter

	Optional Part Number	Part Number of Manufacturer	Manufacturer
Surge absorber	DV0P4190	R•A•V-781BWZ-4	Okaya Electric Industries
Noise filter for signal line	DV0P1460	ZCAT3035-1330	TDK
Noise filter for signal line	—	RJ8035	KK-CORP.CO.JP
Noise filter	DV0PM20042	3SUP-HU10-ER-6	Okaya Electric Industries

### 8-2-7 Grounding

- (1) In order to avoid an electric shock, make sure to connect a protection ground terminal (  ) of the servo amplifier and the protection ground (PE) of the control panel.
- (2) Do not tighten the connection to the protection ground terminal (  ) along with other parts. The servo amplifier has two protection ground terminals.

### 8-3 Compliance with UL Standard

Certified by the UL508C (file No. E164620) standard by observing the installation conditions 1, 2 below.

[1] Use the servo amplifier under the environment of pollution level 2 or 1 defined in IEC60664-1.

(Example: Installed in the IP54 control panel.)

[2] Make sure to connect a circuit breaker or fuse compliant with UL certification (marked with LISTED  ) between the power supply and the noise filter.

For wiring, use the copper conductor cable of the temperature rating 75deg. Celsius or more.

[3] Overload protection level

The overload protection function of the servo amplifier works when the effective current will be 115% or more of the rated current based on the time property. Check that the effective current of the servo amplifier does not exceed the rated current. Set up the maximum instantaneous allowable current at the Pr0. 13 (first torque limit) and Pr5. 22 (second torque limit).

[4] Motor over-temperature protection is not provided. Motor over-load-temperature protection shall be provided at the final installation upon required by the NEC (National Electric Code).

## 9. Compliance with SEMI F47 Instantaneous Stop Standard

- This function corresponds to the F47 power supply instantaneous stop standard in the SEMI standard during no/ light load condition.
- Useful when used in the semiconductor manufacturing equipment.

**Warning:**

Make sure to evaluate and confirm the compliance with F47 power supply instantaneous stop standard with an actual device.



## SAFETY PRECAUTIONS

### 10. Safety precautions

- Danger and damage is expected to occur when the equipment is used ignoring safety precautions. The danger and damage is described in the following categories as indicated by the signs.

	Description of this sign indicates “urgent danger that may cause death or serious injury.”
	Description of this sign indicates “danger that may cause injury or property damage.”

- Rules to keep are categorized and described with the following graphics.

	This graphic indicates “Prohibited” acts that are not permitted.
	This graphic indicates “Mandatory” acts that must be performed forcibly.



- (1) Be sure not to store or use the equipment under conditions subjected to vibrations (5.88m/s<sup>2</sup> or heavier) or an impact shock, foreign matters such as dust, metal particles oil mist, liquids such as water, oil and polishing liquid, near flammable objects, in an atmosphere of corrosive gas (such as H<sub>2</sub>S, SO<sub>2</sub>, NO<sub>2</sub>, Cl<sub>2</sub>), or in an atmosphere of flammable gas.
- (2) Do not place any flammable objects near a motor, an amplifier, or a regenerative resistor.
- (3) Do not drive the motor with an external force.
- (4) Do not damage or strain the cable, or do not apply excessive stress. Do not place a heavy item on the cable or do not pinch the cable.
- (5) Do not use the equipment with the cable soaked in oil or water.
- (6) Do not install the equipment near a heating object such as a heater or a large wire-wound resistor. (Install a heat-shielding plate to avoid influences of a heating object.)
- (7) Do not connect the motor directly with a commercial power.
- (8) Do not use the equipment under conditions subject to strong vibrations or an impact shock.
- (9) Be sure not to touch a rotating part of a motor during operation.
- (10) Do not touch the key flutes of motor output shaft with bare hands.
- (11) Be sure not to touch inside a servo amplifier.
- (12) Motor amplifier heat sink and peripheral devices become very hot. Do not touch those devices.
- (13) Do not carry out wiring or do not operate the equipment with wet hands.





## SAFETY PRECAUTIONS



- (14)Wiring work is strictly allowed only for an engineer specializing electrical work.
- (15)A motor other than specified is not provided with a protection device. Protect a motor with an over current protection device, a ground-fault interrupter, overheating protection device, and emergency stop device, etc.
- (16)When operating the amplifier after an earthquake, inspect installation conditions of the amplifier and the motor and safety of the equipment to make sure that no fault exists.
- (17)After turning off the power, the inside circuit remains charged at a high voltage for a while. When moving, wiring or inspection the equipment, completely shut off the power supply input outside the amplifier and leave for 15 minutes or longer before working.
- (18)Install and mount the equipment securely to prevent personal injury caused by poor installation or mounting on an earthquake.
- (19)Install an external emergency shutoff circuit to stop operation and interrupt power immediately upon emergency.  
Emission of smoke or dust may occur due to a fault of a motor or an amplifier used in combination. For example, if the system is energized with the regenerative control power transistor shorted by failure, overheating of a regenerative resistor installed outside the amplifier may occur and it may emit smoke and dust. If a regenerative resistor is connected outside an amplifier, provide a means of detecting overheating such as a thermal protector to shut off power upon detecting abnormal heating.
- (20)Mount the motor, the amplifier and the peripheral devices on a noncombustible material such as metal.
- (21)Provide correct and secure wiring. Insecure wiring or incorrect wiring may cause runaway or burning of a motor. During wiring work, avoid entry of conductive dust such as wire chippings in an amplifier.
- (22)Connect cables securely and provide secure insulation on current-carrying parts using insulation material.
- (23)Be sure to install a fuses breaker in a power supply. Be sure to connect grounding terminals and grounding wires.  
To prevent an electric shock and malfunction, type D grounding (grounding resistance at 100Ω or lower) or higher grade is recommended..



## ATTENTION



- (24)Do not hold cables or motor shaft when carrying the equipment.
- (25)Do not adjust or change amplifier gains extremely, and do not make operations of the machine instable.
- (26)The equipment may suddenly restart after recovery from shutdown upon a power failure. Keep away from the equipment.  
Specify settings of the equipment to secure safety for human against such restart operations.
- (27)When the equipment is energized, keep away from the motor and mechanism driven by the motor in case of malfunction.
- (28)Avoid a strong shock to the motor shaft.
- (29)Avoid a strong shock to the product.
- (30)Be sure not to use the electromagnetic contactor installed on the main power supply to start or stop the motor.
- (31)Avoid frequent switching on and off the main power supply of the amplifier.
- (32)The built-in brake of the motor is used for holding only. Do not use the brake to stop (braking) for securing safety of the equipment.



## SAFETY PRECAUTIONS



- (33) Do not fall or topple over the equipment when carrying or installing.
- (34) Do not climb the motor or do not place a heavy item on the motor.
- (35) Do not block radiation slits of the amplifier and do not put a foreign matter into the amplifier.
- (36) Do not use the equipment under direct sunlight. When storing the equipment, avoid direct sunlight and store under conditions of operating temperatures and humidity.
- (37) Be sure not to disassemble or modify the equipment.  
Disassembling and repair is allowed only for the manufacturer or sales agency authorized by the manufacturer.
- (38) In normal use, Please do not to use the deceleration stop of the motor that is using dynamic braking capability.  
Due to malfunction or protection function, May arise stopping.  
After a deceleration command, Please use dynamic braking with servo off.
- (39) Do not remove the front panel mounting screws.  
Do not remove the screw and lock again too.



- (40) Use a motor and an amplifier in combination specified by the manufacturer. A customer shall be responsible for verifying performances and safety of combination with other amplifier.
- (41) A failure of a motor or a combined amplifier may cause burning of motor, or emission of smoke and dust. Pay attention when using the equipment in a clean room.
- (42) Install the equipment adequately in consideration of output and main unit weight.
- (43) Keep the ambient conditions of an installed motor within a range of allowable ambient temperatures and of allowable humidity.
- (44) Install the equipment by specified procedures and in specified orientation.
- (45) Install the devices by keeping specified distances between an amplifier and inside control panel or other devices.
- (46) If a motor has an eyebolt, use the eyebolt to carry the motor only. Do not use the eyebolt to carry equipment.
- (47) Connect a relay breaking upon emergency stop in series with a brake control relay.
- (48) For a test run, hold down a motor and disconnect from a mechanical system to verify operations before installing on the equipment. (A motor must run smoothly at 30r/min driven with an amplifier.)
- (49) Verify that an input power supply voltage satisfies the amplifier specifications before turning on the power and start operation.  
An input voltage higher than rated may cause ignition and smoking in the amplifier, which may cause runaway or burning of a motor in some cases.
- (50) When an alarm status occurs, remove a cause of the problem before restarting.  
Careless restarting without removing a cause of problem may cause malfunctioning or burning to the motor.
- (51) The built-in brake of the motor may not be able to hold due to expiring useful life or a mechanical structure. Install a braking device on the equipment to secure safety.
- (52) Pay attention to heat radiation. The amplifier generates heat by operating a motor. An amplifier used in a sealed control box may cause an extreme rise of temperature. Consider cooling so that an ambient temperature around the amplifier satisfies an operating range.
- (53) Maintenance and inspection is allowed only for a specializing person.
- (54) Turn off the power when the equipment is not used for a long term.

Capacitance of the capacitors of power supply rectifier circuit drops over time. To avoid a secondary problem due to a failure, replacement of capacitors is recommended at an interval of approximately 5 years. Commission the manufacturer or sales agency authorized by the manufacturer to replace the parts.

Be sure to read the operating manual (safety book) before use.



## SAFETY PRECAUTIONS

### SERVO DRIVER'S AMBIENT TEMPERATURE

The driver's service life significantly depends on the ambient temperature. Make sure that the driver's ambient temperature (at 5cm distance from the driver) does not exceed the specified operating temperature range.

**Operating temperature range: 0 to 50 °C**

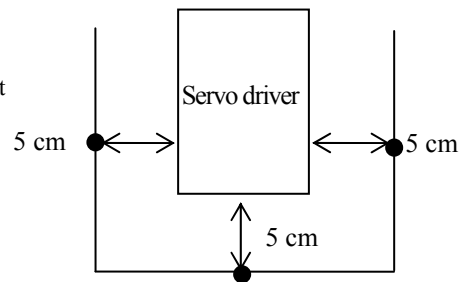

**Panasonic Corporation has made the best efforts to ensure quality of this product. However, application of external noise (include radiation) or static electricity, or a defect of the input power supply, wiring or components may cause the servo amplifier to operate beyond the preset conditions. Therefore, you should exercise thorough caution to ensure safety against an unexpected operation.**

## 11. Life and Warranty

### 11-1 Life Expectancy of the Driver

The Amplifier has 14,000 hours of life expectancy when used continuously under the following conditions.

Definition of life:

Life shall be defined as the time until capacity drop by 20% of electrolytic condenser from factory shipment status.

Conditions	Input power	: Single phase AC 220 V, 50 / 60 Hz ,
	Working temperature.	: 50 degrees C
	Output thrust	: Constant thrust at rating
	Speed	: Constant speed at rating

Note that life may vary depending on usage conditions.

### 11-2 Standard life

In-rush current protection relay

The life expectancy of the inrush current protection circuit is about 20,000 times.

However, it may vary depending on environmental and usage conditions.

### 11-3 Warranty Period

(1) Warranty period shall be 12 months from the ex-factory date or 18 months from the date

of manufacturing. This Warranty shall be exempted in the following cases,

- ① defects resulting from misuse and/or repair or modification by the customer
- ② defects resulting from drop of the Product or damage during transportation
- ③ defects resulting from improper usage of the Product beyond the Specifications
- ④ defects resulting from fire, earthquake, lightening, flood, damage from salt, abnormal voltage or other Act of God, or other disaster.
- ⑤ defects resulting from the intrusion of foreign material to the Product, such as water, oil or metallic particles.

This Warranty shall be exempted when the life of the components described on the above exceeds its standard life.

(2) Warranty scope

Panasonic warrants the replacement of the defected parts of the Product or repair of them when the defects of the Product occur during the Warranty Period, and when the defects are under Panasonic's responsibility. This Warranty only covers the Product itself and does not cover a any direct and indirect damage incurred by such defects.

## 12. Others

- Precautions for export of this product and the equipment incorporating this product  
If the end user or end purpose of this product relates to military affairs, armament and so on, this product may be subject to the export regulations prescribed in "Foreign Exchange and Foreign Trade Control Law". To export this product, take thorough examination, and follow the required export procedure.
- We cannot warrant this product, if it is used beyond the specified operating conditions.
- Compliance with the relevant standards should be considered by the user.
- The final decision on the compatibility with the installations and components at the user's site, in terms of structure, dimensions, characteristics and other conditions should be made by the user.
- If the user selects the servo motor and amplifier for user machine, the user shall pay deep attention to matching servo motor and driver to his machine.
- For performance improvement or other reasons, some components of this product may be modified in a range that satisfies the specifications given in this document.
- Any specification change shall be based on our authorized specifications or the documents presented by the user. If a specification change may affect the functions and characteristics of this product, we will produce a trial product, and conduct examination in advance. Note that the produce price may be changed with a change in its specifications.
- We have made the best efforts to ensure the product quality. However, complete equipment at customer's site may malfunction due to a failure of this product. Therefore, take precautions by providing fail-safe design at customer's site, and ensure safety within the operating range of the work place.
- Depending on the malfunction of this product, it may generate smoke of about one cigarette. Take this into consideration when the application of the machine is used in clean room etc.
- If the equipment is operating without connection of the motor shaft electrically to the ground, electrolytic corrosion occurs at the motor bearing and it may result in a high bearing noise depending on equipment or installing conditions. The user shall verify and inspect the equipment.
- Be careful that using the equipment under the environment with high concentrations of sulfur or sulfated gases, leads to the disconnection from the chip resistor and/or a bad contact connection.
- Take care to avoid inputting a supply voltage which significantly exceeds the rated range to the power supply of this product. If it exceeds the rated range, it may result in the damage to the internal parts, causing fuming and/or ignition etc...
- Please adequately dispose of the battery to be insulated by using a tape, in accordance with each country and each local regulation and law.
- Please dispose of the equipment as the industrial waste.

## Specifications by Model (Global Models)

Model		MBDJT2207	MBDJT2210	MCDJT3220	MCDJT3230
Power supply input		Single-phase 220 V	Single-phase 220 V	Single-phase 220 V	Single-phase 220 V
Maximum instantaneous output current		15 A	15 A	30 A	30 A
Maximum continuous output current		7 A	10 A	20 A	30 A
Rotary encoder feedback signal		Resolution: 10000 P/r	Resolution: 10000 P/r	Resolution: 10000 P/r	Resolution: 10000 P/r
Regenerative discharge resistor		Externally connect	Externally connect	Externally connect	Externally connect
External Regenerative register	optional parts	DVOPM20028	DV0PM20028	DV0PM20028	DV0PM20028
	optional parts	DV0P4283	DV0P4283	DV0P4283	DV0P4284
	Maker optional parts	RF180B	RF180B	RF180B	RF240
Auto gain tuning function		Provided	Provided	Provided	Provided
Dynamic brake function		Provided	Provided	Provided	Provided
Ambient temperature		0-50°C	0-50°C	0-50°C	0-50°C
Main power supply cable		HVSF 0.75~2.0 mm <sup>2</sup>	HVSF 0.75~2.0 mm <sup>2</sup>	HVSF 0.75~2.0 mm <sup>2</sup>	HVSF 0.75~2.0 mm <sup>2</sup>
		AWG14~18	AWG14~18	AWG14~18	AWG14~18
Ground cable		HVSF 2.0 mm <sup>2</sup>	HVSF 2.0 mm <sup>2</sup>	HVSF 2.0 mm <sup>2</sup>	HVSF 2.0 mm <sup>2</sup>
		AWG14	AWG14	AWG14	AWG14
Motor cable		HVSF 0.75~2.0 mm <sup>2</sup>	HVSF 0.75~2.0 mm <sup>2</sup>	HVSF 0.75~2.0 mm <sup>2</sup>	HVSF 0.75~2.0 mm <sup>2</sup>
		AWG14~18	AWG14~18	AWG14~18	AWG14~18
Inrush Current (Main Power Supply) (*1)		Max. 15 A	Max. 15 A	Max. 31 A	Max. 31 A
Inrush Current (Control Power Supply) (*1)		Max. 31 A	Max. 31 A	Max. 31 A	Max. 31 A
Dimensions		Size B	Size B	Size C	Size C