

# Solutions for the packaging industry

Servo drives · Sensors · PLCs  
Touch terminals · Laser markers



**IN Your  
Innovation**





## CARTONING MACHINE

### Economic concepts for machines:

Coordination of up to 32 axes with the GM1 Motion Controller for modular machine concepts

### Dynamic machines:

Fast start-up with the MINAS A6 servo drives and short response times thanks to Ethernet communication with the FP7 PLC

### Perfect packaging results:

FX and CX sensors: Detection of glue dots and monitoring of the carton stack height in the magazine



### Economic concepts for machines:

Conveyor drives with MINAS LIQI for an effective price-performance ratio

## LABELER

### Dynamic machines:

Reliable MINAS A6 servo drives for excellent agile acceleration behavior

### Perfect packaging results:

EX/CX sensors for reliable detection of labels, even if carrier films and labels are transparent

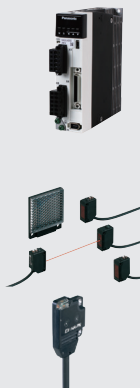

### Economic concepts for machines:

Compact PLCs FP0H and FP0R with dedicated program: Powerful hardware with a small footprint and uncomplicated programming

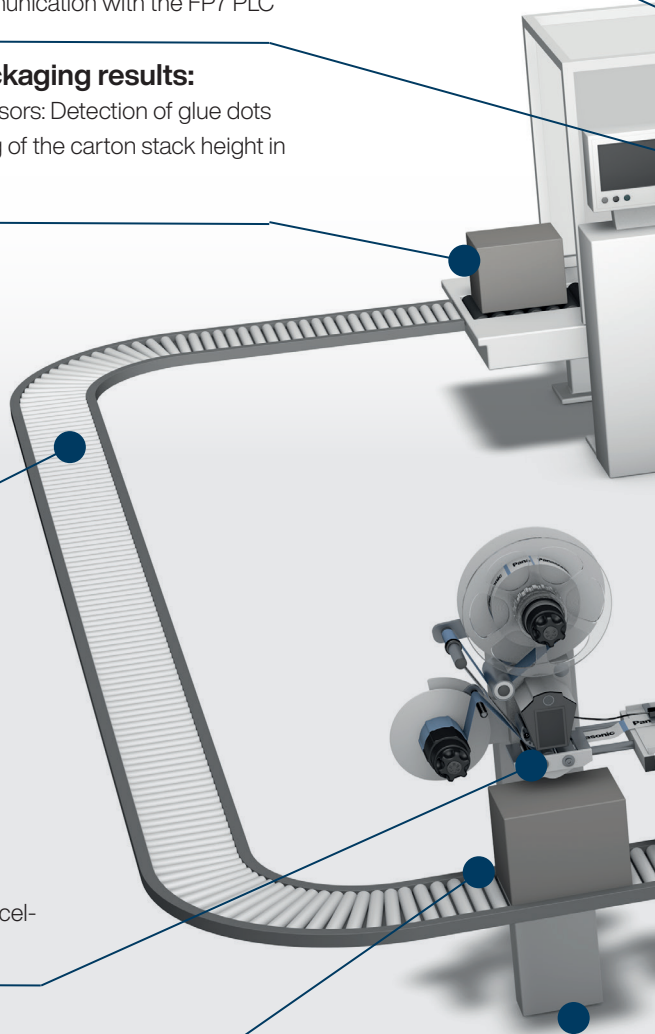

## LASER MARKER

**Perfect packaging results:**  
Expiration date without fading

## HORIZONTAL FLOW WRAPPER

**Ready for Industry 4.0:**  
Corvina Cloud for remote monitoring and recording of operational data

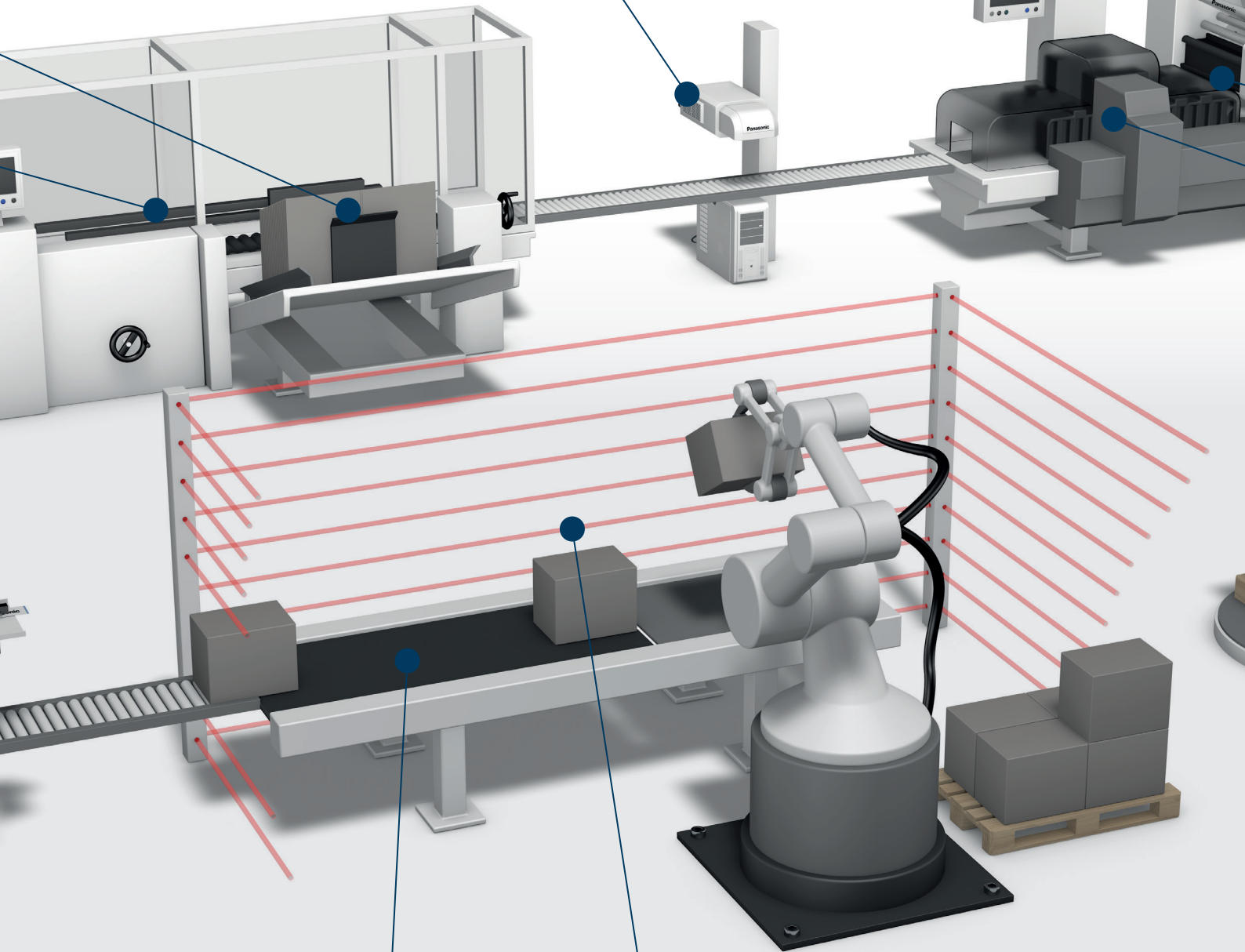

**Operator safety:**  
Low-voltage drivers and motors for 24/48V DC

## PALLETIZER

**Flexibility:**  
Safety light curtain SF4D with muting/blanking and analysis via IO-Link



### Dynamic machines:

Dynamic machines that are easy to use: HM panels for high-resolution visualization, high connectivity, and FPOH PLC for dancer control



### Perfect packaging results:

Ionizers prevent contamination of the foil



### Perfect packaging results:

LX sensor series for reliable detection of cutmarks and HG-C measurement sensors for checking whether the packaging has been closed correctly



### Economic concepts for machines:

Multi-axis servo driver MINAS A6 Multi in book-size design



### Sustainability put into practice:

Paper as a packaging material is once again the focus of interest. With our CX sensor family, you can reliably detect even smooth paper – but this sensor group is also suitable for detecting plastic films. If installation space is very limited, we recommend using the EX sensor series.

## STRETCH WRAPPER

### Comprehensive technical solutions from one source:

- Touch terminal
- Control unit
- Servo driver and motor
- Sensor



We will happily advise you on your individual applications:

→ [verpackungsmaschinen@eu.panasonic.com](mailto:verpackungsmaschinen@eu.panasonic.com)

## Solutions for the packaging industry

Nowadays, production cycles are getting faster and faster, and the technical challenges in the industry are constantly increasing. This is noticeable in all industries. In the packaging industry, for example, you are repeatedly faced with the following tasks:

- > Machines have to provide maximum efficiency while at the same time offering the highest possible flexibility
- > Perfect packaging results are expected with the lowest possible cycle time
- > The optimization of raw materials and resources is one of the most important topical issues not only for reasons of environmental protection, but also from a cost point of view
- > Industry 4.0, IoT, digitization... you have to master the technical trends – without having to set up your own IT departments or having to replace the entire machine park

To meet these challenges, it is helpful to have an experienced and

**competent partner** at your side.

Panasonic has gained more than **six decades of know-how** in **automation technology** in the company's 100-year history.

The comprehensive product portfolio is almost unique in the market. In addition to **worldwide availability**, Panasonic customers benefit from our excellent quality and **outstanding service**.

Experienced technical experts can be reached quickly and personally via the service hotline

**Tel.: +49 89 45354-2750**

E-mail: [verpackungsmaschinen@eu.panasonic.com](mailto:verpackungsmaschinen@eu.panasonic.com)



### Panasonic – quality and efficiency from a single source

**Quality** plays a **very important** role at Panasonic: All our products undergo **series of intensive tests** in order to offer you the highest quality for your machines. In addition, we grant a **three-year warranty** on all our products (excluding laser markers, 2 years).

The best possible solution for your machine may lie in the details – this is why we offer **individual product customization**.

Thanks to a large number of products such as programmable controllers, servo motors and servo drivers, sensors, safety solutions, and laser marking systems as well as a comprehensive service portfolio, Panasonic is a competent partner for the packaging industry.

# Panasonic

## INDUSTRY



We are dedicated to the highest standards of global sustainability as **Your Committed Enabler**. Find out more on our [website](#).

## Panasonic Industry Europe GmbH

Caroline-Herschel-Strasse 100  
85521 Ottobrunn  
Tel. 49 89 45354-1000  
[info.pieu@eu.panasonic.com](mailto:info.pieu@eu.panasonic.com)  
[industry.panasonic.eu](http://industry.panasonic.eu)