

Panasonic® FP I/O Terminal Board

Installation
Instructions

MJEC-FPIOTB No.0074-44V

Read these instructions carefully and carry out the installation in the prescribed manner. After installation, keep it in a safe place for reference when required.

■ Safety Precautions

⚠ WARNING

- Always take precautions to ensure the overall safety of your system, so that the whole system remains safe in the event of failure of this product or other external factor.
- Do not use this product in areas with inflammable gas. It could lead to an explosion.
- Exposing this product to excessive heat or open flames could lead to damage to the lithium battery or other electronic parts.

⚠ CAUTION

- To prevent excessive exothermic heat or smoke generation, use this product at the values less than the maximum of the characteristics and performance that are assured in these specifications.
- Do not dismantle or remodel the product. It could lead to excessive exothermic heat or smoke generation.
- Do not touch the terminal while turning on electricity. It could lead to an electric shock.
- Use the external devices to function the emergency stop and interlock circuit.
- Connect the wires or connectors securely. The loose connection could lead to excessive exothermic heat or smoke generation.
- This product has been developed / produced for industrial use only.

1 Before using the unit

■ Operating environment

- Ambient temperature : 0 to + 55 °C
- Ambient humidity : 30 to 85 % RH (at 25°C, no condensation)
- Places without excessive dust, oil mist, conductive dust, and any inflammable and corrosive gases.
- Pollution Degree 2
- Places unexposed to water, oil and chemicals.
- Places without excessive vibration or shock.
- Places away from high voltage cables (equipment), power transmission lines (equipment), radio transmitters, equipment that would generate high switching surge and the top of equipment with high calorific power. (Distance: At least 100 mm)

■ Proper handling

- Do not touch connector pins directly to prevent static electricity from causing damage.
- Always rid yourself of any static electricity before handling this product.

2 Part names and dimensions

■ Main unit

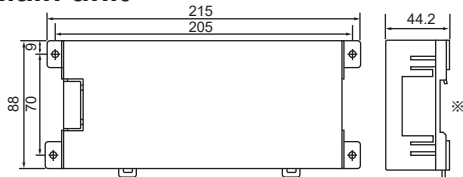

■ Mounting holes (Unit : mm)

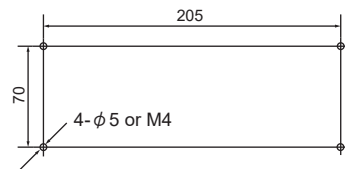

■ Installing to a DIN rail

- 35mm DIN rail

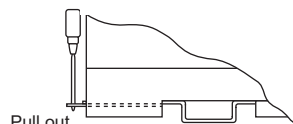
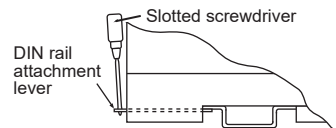

3 Recommended transmission cables

Cable	Max. transmission distance Total length	Sample appropriate cable
Shielded twisted pair	700 m	Hitachi Cable, Ltd. KPEV-S1P × 1.25SQ / Belden 9860
	600 m	Hitachi Cable, Ltd. KPEV-S1P × 0.5SQ / Belden 9207
VCTF	400 m	VCTF 0.75mm ² × 2C (JIS)

- As polyvinyl chloride has lower electrical characteristics than polyethylene, the max. transmission distance is shorter.
- Use shielded twisted pair cables.
- Use only one type of transmission cable. Do not mix more than 1 type.
- Twisted pair cables are recommended in noisy environments.

4 Wiring

■ Connecting diagrams of power supply and I/O terminals

- Power supply circuit (common to AFP87444 and 87432)
- Input circuit (common to AFP87444 and 87432)

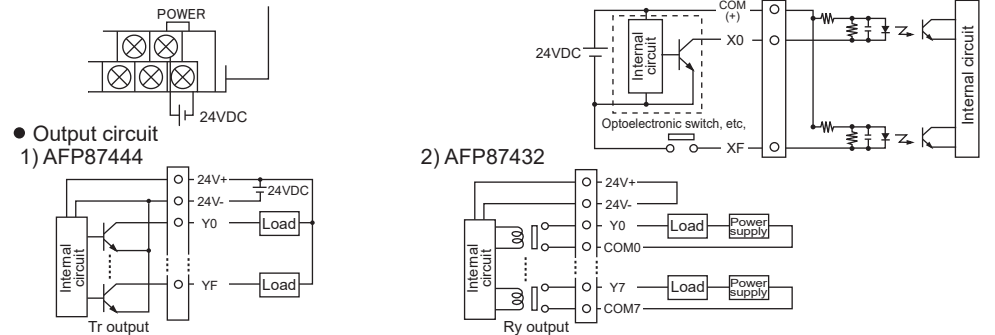

■ Terminals

- 1) Power supply and I/O terminal (M3)
- 2) Transmission line terminal (M3.5)

※AFP87444, 87432 only

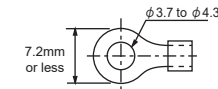
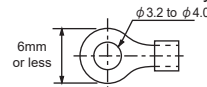

- Suitable crimp terminals are bare round type terminals, bare round type terminals with insulating paper and fork type terminals.
- Securely fasten the terminals applying a tightening torque of 0.5 to 0.6 N m.

■ Connecting diagram of transmission line

- For the transmission cables, connect the (+) and (+) sides, and (-) and (-) sides.
- The wiring of the transmission cable should extend from one unit to the next. Do not run two wires from a single unit to two other units.
- For the details of recommended cables, terminator settings, refer to MEWNET-F Manual.
- When using the shielded transmission cable, ground one end of the shield.

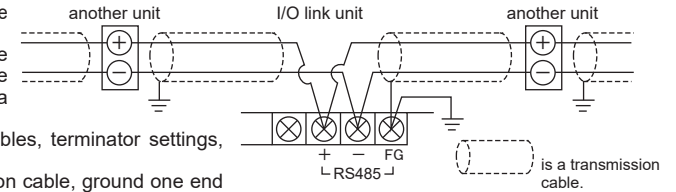

Moreover, when using the FP2 series, in addition to this instructions, familiarize yourself with the manual right.

Manual
Programmable Controller MEWNET-F (Remote I/O System) Manual

Panasonic Corporation

Panasonic Industrial Devices SUNX Co., Ltd.
<https://panasonic.net/id/pidsx/global>

Please visit our website for inquiries and about our sales network.

PRINTED IN JAPAN

© Panasonic Industrial Devices SUNX Co., Ltd. 2022