

Programmable Controller
FP7 Multi Input/Output Unit
User's Manual

Supported models

- AFP7MXY32DWD
- AFP7MXY32DWDH

(MEMO)

Introduction

Thank you for purchasing a Panasonic product. Before you use the product, please carefully read through the user's manual, and understand it in detail to use the product properly.

Types of Manual

- There are different types of user's manual for the FP7 series, as listed below. Please refer to a relevant manual for the unit and purpose of your use.
- The manuals can be downloaded from the Panasonic website:<https://industry.panasonic.com/global/en/downloads/?tab=manual>.

Unit name or purpose of use	Manual name	Manual code
FP7 Power Supply Unit	FP7 CPU Unit User's Manual (Hardware)	WUME-FP7CPUH
FP7 CPU Unit	FP7 CPU Unit Command Reference Manual	WUME-FP7CPUPGR
	FP7 CPU Unit User's Manual (Logging Trace Function)	WUME-FP7CPULOG
	FP7 CPU Unit User's Manual (Security Function)	WUME-FP7CPUSEC
	Instructions for Built-in LAN Port	FP7 CPU Unit User's Manual (LAN Port Communication)
FP7 CPU Unit User's Manual (Ethernet Expansion Function)		WUME-FP7CPUETEX
FP7 CPU Unit User's Manual (EtherNet/IP Communication)		WUME-FP7CPUEIP
Web Server Function Manual		WUME-FP7WEB
Instructions for Built-in COM Port	FP7 Series User's Manual (SCU Communication)	WUME-FP7COM
FP7 Extension Cassette (Communication) (RS-232C / RS485 type)		
FP7 Extension Cassette (Communication) (Ethernet Type)	FP7 Series User's Manual (Communication Cassette Ethernet Type)	WUME-FP7CCET
FP7 Extension (Function) Cassette Analog Cassette	FP7 Analog Cassette User's Manual	WUME-FP7FCA
FP7 Digital Input / Output Unit	FP7 Digital Input / Output Unit User's Manual	WUME-FP7DIO
FP7 Analog Input Unit	FP7 Analog Input Unit User's Manual	WUME-FP7AIH
FP7 Analog Output Unit	FP7 Analog Output Unit User's Manual	WUME-FP7AOH
FP7 Thermocouple Multi-analog Input Unit	FP7 Thermocouple Multi-analog Input Unit	WUME-FP7TCRTD
FP7 RTD Input Unit	FP7 RTD Input Unit User's Manual	
FP7 Multi Input / Output Unit	FP7 Multi Input / Output Unit User's Manual	WUME-FP7MXY
FP7 High-speed counter unit	FP7 High-speed Counter Unit User's Manual	WUME-FP7HSC
FP7 Pulse Output Unit	FP7 Pulse Output Unit User's Manual	WUME-FP7PG

Unit name or purpose of use	Manual name	Manual code
FP7 Positioning Unit	FP7 Positioning Unit User's Manual	WUME-FP7POSP
FP7 Serial Communication Unit	FP7 Series User's Manual (SCU Communication)	WUME-FP7COM
FP7 Multi-wire Link Unit	FP7 Multi-wire Link Unit User's Manual	WUME-FP7MW
FP7 Motion Control Unit	FP7 Motion Control Unit User's Manual	WUME-FP7MCEC
PHLS System	PHLS System User's Manual	WUME-PHLS
Programming Software FPWIN GR7	FPWIN GR7 Introduction Guidance	WUME-FPWINGR7

Safety Precautions

- Observe the following precautions to ensure personal safety or to prevent accidents.
- Before performing installation, operation, maintenance, or inspection, read this manual carefully to understand how to use the product correctly.
- Make sure that you fully understand the product, information on safety, and other precautions.
- This manual uses two safety symbols, different levels of safety precautions “Warning” and “Caution”, to indicate .



WARNING

Indicates a potentially hazardous situation which, if not handled correctly, could result in death or serious injury of the user.

- Take safety measures outside the product to ensure the safety of the entire system even if this product fails or an error occurs due to external factors.
- Do not use this product in atmospheres that contain flammable gases.
Doing so may result in explosion.
- Do not throw this product into the fire.
Doing so may cause the batteries or other electronic parts to explode.



CAUTION

Indicates a potentially hazardous situation which, if not handled correctly, could result in injury to the user or property damage.





- To prevent abnormal heat generation or smoke generation, use this product with some leeway from the guaranteed characteristics and performance values of the product.
- Do not disassemble or modify this product.
Doing so may result in abnormal heat generation or smoke generation.
- Do not touch any terminals while the power is on.
Doing so may result in electrical shock.
- Configure emergency stop and interlock circuits outside this product.
- Connect wires and connectors properly.
Failure to do so may result in abnormal heat generation or smoke generation.
- Do not perform work (such as connection or removal) with the power turned on.
Doing so may result in electrical shock.
- If this product is used in any way that is not specified by Panasonic, its protection function may be impaired.
- This product has been developed and manufactured for industrial use only.

Copyright / Trademarks

- The copyright of this manual is owned by **Panasonic Industry Co., Ltd.**
- Unauthorized reproduction of this manual is strictly prohibited.
- Windows is a registered trademark of Microsoft Corporation in the U.S. and other countries.
- Other company and product names are trademarks or registered trademarks of their respective companies.

Handling Precautions

- **In this manual, the following symbols are used to indicate safety information that must be observed.**

	Indicates an action that is prohibited or a matter that requires caution.
	Indicates an action that must be taken.
	Indicates supplemental information.
	Indicates details about the subject in question or information useful to remember.

12

Procedure

Indicates operation procedures.

Table of Contents

1 Unit Functions and Restrictions	1-1
1.1 Unit Functions and Operation	1-2
1.1.1 Unit Functions	1-2
1.1.2 Unit Type and Product Number.....	1-3
1.2 Restrictions on Units Combination.....	1-4
1.2.1 Restrictions by Power Consumption	1-4
1.2.2 Applicable Versions of FPWIN GR7 and Units	1-4
1.2.3 Restrictions on Interrupt Function	1-5
1.2.4 Restrictions on I/O Allocation.....	1-5
2 Names and functions of parts	2-1
2.1 Names and functions of parts	2-2
2.1.1 Names and functions of parts	2-2
2.1.2 Operation monitor LEDs	2-2
2.1.3 Mode setting switches.....	2-3
3 Input/Output Specifications and Wiring	3-1
3.1 Input/Output Specifications	3-2
3.1.1 Characteristics of Input/Output Circuits	3-2
3.1.2 I/O Terminal Layout Diagram	3-2
3.1.3 Output Specifications	3-5
3.2 Wiring of Input and Output.....	3-8
3.2.1 Common Precautions to Input and Output.....	3-8
3.2.2 Input Wiring.....	3-8
3.2.3 Output Wiring	3-9
3.3 Connection Using the Discrete-wire Connector	3-11
3.3.1 Specifications of Wire-pressed Terminal Cable	3-11
3.3.2 Wiring the Discrete-wire Connector	3-12
3.4 Connection Using the Push-In Connector	3-15
3.4.1 About Push-In Connector.....	3-15
3.4.2 Compatible Parts and Dedicated Tools.....	3-15
3.4.3 Wiring to Connector	3-15
4 Unit Allocation	4-1
4.1 Unit Allocation	4-2
4.1.1 Number of Occupied I/O Points for the Unit.....	4-2
4.1.2 Confirmation of I/O Allocation Information	4-2
4.1.3 Registration in I/O Map	4-3
5 Multi I/O Unit Setting	5-1
5.1 Basic Setup.....	5-2
5.1.1 Basic setting item	5-3
5.2 Output Terminal Setting	5-4
5.2.1 Overview	5-4
5.2.2 Allocation of Contacts to Output Terminals	5-5

5.2.3	Application to Differential Output.....	5-6
5.3	Application Setting	5-9
5.3.1	Overview	5-9
5.3.2	Setting Items by Use.....	5-9
6	Interrupt Function	6-1
6.1	Interrupt Function.....	6-2
6.1.1	Overview of Interrupt Function.....	6-2
6.1.2	Setting of Unit Body	6-2
6.1.3	Configuration Using Tool Software.....	6-2
6.1.4	Overview of Interrupt Program.....	6-4
6.1.5	Precautions for Use	6-5
6.2	Execution Example of Interrupt Function	6-6
6.2.1	External Interrupt Input	6-6
6.2.2	Comparison Match Interrupt	6-7
7	Counter Function	7-1
7.1	Counter Function	7-2
7.1.1	Overview of Counter Function	7-2
7.1.2	Configuration Using Tool Software.....	7-3
7.1.3	Linear Counter and Ring Counter	7-4
7.1.4	Selection of Count Methods.....	7-6
7.2	Control Signals.....	7-9
7.2.1	Reset and Mask	7-9
7.3	Read/Write of Elapsed Value	7-10
7.3.1	Elapsed Value When Power Turns On.....	7-10
7.3.2	Reading Elapsed Value.....	7-10
7.3.3	Changing Elapsed Value.....	7-10
7.3.4	Resetting/Presetting Elapsed Value.....	7-10
7.4	Elapsed Value Hold Function.....	7-12
7.4.1	Overview	7-12
7.4.2	Operation	7-13
7.5	Input Frequency Measurement Function	7-14
7.5.1	Overview	7-14
7.5.2	Reading Measurement Value.....	7-14
8	Comparison Output Function	8-1
8.1	Comparison Output Function.....	8-2
8.1.1	Overview of Comparison Output Function	8-2
8.1.2	Comparison Output and Comparison Match Signal.....	8-3
8.1.3	Configuration Using Tool Software.....	8-3
8.2	Execution Example of Comparison Output Function	8-6
8.2.1	Comparison Output of Counter for External Input.....	8-6
9	Pulse Output/PWM Output Function	9-1
9.1	Pulse Output / PWM Output Function.....	9-2
9.1.1	Overview of Pulse Output / PWM Output Function.....	9-2
9.1.2	Pulse Output Function Settings	9-2
9.1.3	Pulse Start Logic.....	9-3

9.1.4	Configuration Using Tool Software.....	9-4
9.1.5	Data Update Timing (Output Frequency).....	9-6
9.1.6	Data Update Timing (Duty Ratio).....	9-7
9.2	Control Signals.....	9-10
9.2.1	Enable and Start	9-10
9.2.2	Reset.....	9-10
9.3	Read/Write of PLS/PWM Counter Elapsed Value.....	9-12
9.3.1	Elapsed Value When Power Turns On.....	9-12
9.3.2	Reading PLS/PWM Counter Elapsed Value	9-12
9.3.3	Changing PLS/PWM Counter Elapsed Value	9-12
9.4	Execution Example of Pulse Output / PWM Output Function	9-13
9.4.1	Setting Example of Pulse Output	9-13
9.4.2	Setting Example of Pulse Output (Frequency Change).....	9-14
9.4.3	Setting Example of Pulse Output (Comparison Match Stop).....	9-16
9.4.4	Setting Example of PWM Output	9-18
10	Positioning Function (H type).....	10-1
10.1	Positioning Function.....	10-3
10.1.1	Overview of Positioning Function.....	10-3
10.1.2	Control Mode	10-4
10.2	Wiring.....	10-6
10.2.1	Connection Diagram with Servo Motor Amplifier	10-6
10.2.2	Connections with Servo Motor Amplifier	10-9
10.2.3	Connection with Stepping Motor Driver	10-9
10.3	Initial Operation Check.....	10-11
10.3.1	Safety Circuit Design	10-11
10.3.2	Before Turning On the Power	10-12
10.3.3	Power-on and Power-off Sequences	10-13
10.3.4	After Turning On the Power	10-13
10.4	Setting of Positioning Function	10-15
10.4.1	I/O Allocation of Positioning Function	10-15
10.4.2	Configuration Using Tool Software.....	10-16
10.5	Positioning Table Settings (Configurator PMX).....	10-20
10.5.1	Used Channel Setting	10-20
10.5.2	Parameter Settings	10-22
10.5.3	Creating Positioning Data Table.....	10-24
10.5.4	Saving Positioning Parameters.....	10-27
10.5.5	Export and Import	10-28
10.5.6	Check on Parameter Data	10-28
10.5.7	Writing Parameters to Unit.....	10-29
10.6	Read/Write of Elapsed Value	10-30
10.6.1	Elapsed Value (Current Value) Area	10-30
10.6.2	Reading Elapsed Value (Current Value) Area.....	10-30
10.7	Stop Control.....	10-31
10.7.1	Type of stop operations.....	10-31
10.7.2	Characteristics of Stop Operations	10-32
10.8	JOG operation.....	10-34
10.8.1	Setting and Operation of JOG Operation.....	10-34
10.8.2	Setting and Operation of JOG Operation (Speed Changes).....	10-36

10.8.3	Speed Changes in JOG Operation	10-39
10.9	Home Return.....	10-40
10.9.1	Types of Home Return	10-40
10.9.2	Operation Patterns of Home Return Operation.....	10-41
10.9.3	Settings and Operations of Home Return	10-43
10.10	Positioning Control.....	10-47
10.10.1	Types of Positioning Controls	10-47
10.10.2	E-point Control (Single Speed Positioning).....	10-48
10.10.3	P-point Control (Double Speed Positioning)	10-50
10.10.4	C-point control.....	10-52
10.10.5	J-point Control (JOG Positioning)	10-54
10.10.6	J-point Control (JOG Positioning: Speed Changes)	10-57
10.10.7	Programming Cautions	10-60
10.11	Repeat Operation.....	10-61
10.11.1	Overview of Repeat Operation	10-61
10.11.2	Settings and Operations of Repeat Operation	10-62
10.11.3	Stop Operation During Repeat Operation	10-64
10.12	Linear Interpolation Control	10-66
10.12.1	Overview	10-66
10.12.2	Setting and Operation of Linear Interpolation	10-66
10.13	Operational Difference Between Speed Parameters	10-69
10.13.1	Startup speed.....	10-69
10.13.2	Operation Patterns and Start Speed Settings.....	10-69
10.14	Other Characteristics	10-71
10.14.1	Memory Backup	10-71
10.14.2	Activation of Each Operation	10-71
10.14.3	Operation When CPU Mode Changes From RUN To PROG.	10-71
11	Other Functions	11-1
11.1	Creating of Ladder Programs Using Templates	11-2
11.1.1	Overview of Template Input Function	11-2
11.1.2	Creating Reading/Writing Program	11-3
12	Troubleshooting.....	12-1
12.1	Confirming Errors Using Self-diagnostic Function	12-2
12.1.1	Checking the LED Display of Unit.....	12-2
12.1.2	Operation Mode When an Error Occurs	12-2
12.2	Troubleshooting	12-4
12.2.1	ERR LED Turns ON on the Unit.....	12-4
12.2.2	What to Do When Positioning Error Occurs.....	12-5
12.2.3	ERR LED is Flashing on the Unit.....	12-7
13	Specifications.....	13-1
13.1	Specifications.....	13-2
13.1.1	General Specifications	13-2
13.1.2	Function Specifications (AFP7MXY32DWD/AFP7MXY32DWDH)	13-3
13.1.3	Positioning Function Specifications (AFP7MXY32DWDH).....	13-4
13.2	Allocation of I/O Numbers.....	13-6
13.2.1	Input.....	13-6

13.2.2 Output	13-9
13.3 List of Unit Memories	13-14
13.3.1 Role of Unit Memories	13-14
13.3.2 List of Unit Memories (AFP7MXY32DWD/ AFP7MXY32DWDH) ..	13-15
13.3.3 List of Unit Memories (AFP7MXY32DWDH).....	13-17
13.4 Unit Memory Detailed Information	13-24
13.4.1 Alarm/Error/Warning	13-24
13.4.2 Input setting	13-25
13.4.3 Output Setting	13-27
13.4.4 Interrupt Setting Area	13-29
13.4.5 Counter Mode Setting Area	13-30
13.4.6 Counter Monitor Setting Area	13-31
13.4.7 Comparison Output Setting Area	13-33
13.4.8 Pulse Output / PWM Output Setting Area	13-35
13.4.9 Pulse Output/PWM Output Monitor Setting Area	13-36
13.5 Unit Memory Detailed Information (H type).....	13-39
13.5.1 Common Area	13-39
13.5.2 Axis Information Area.....	13-40
13.5.3 Axis Setting Area	13-41
13.5.4 Positioning Table Area	13-44
13.6 Dimensions	13-52

(MEMO)

1 Unit Functions and Restrictions

1.1 Unit Functions and Operation	1-2
1.1.1 Unit Functions	1-2
1.1.2 Unit Type and Product Number	1-3
1.2 Restrictions on Units Combination	1-4
1.2.1 Restrictions by Power Consumption	1-4
1.2.2 Applicable Versions of FPWIN GR7 and Units	1-4
1.2.3 Restrictions on Interrupt Function	1-5
1.2.4 Restrictions on I/O Allocation	1-5

1.1 Unit Functions and Operation

1.1 Unit Functions and Operation

1.1.1 Unit Functions

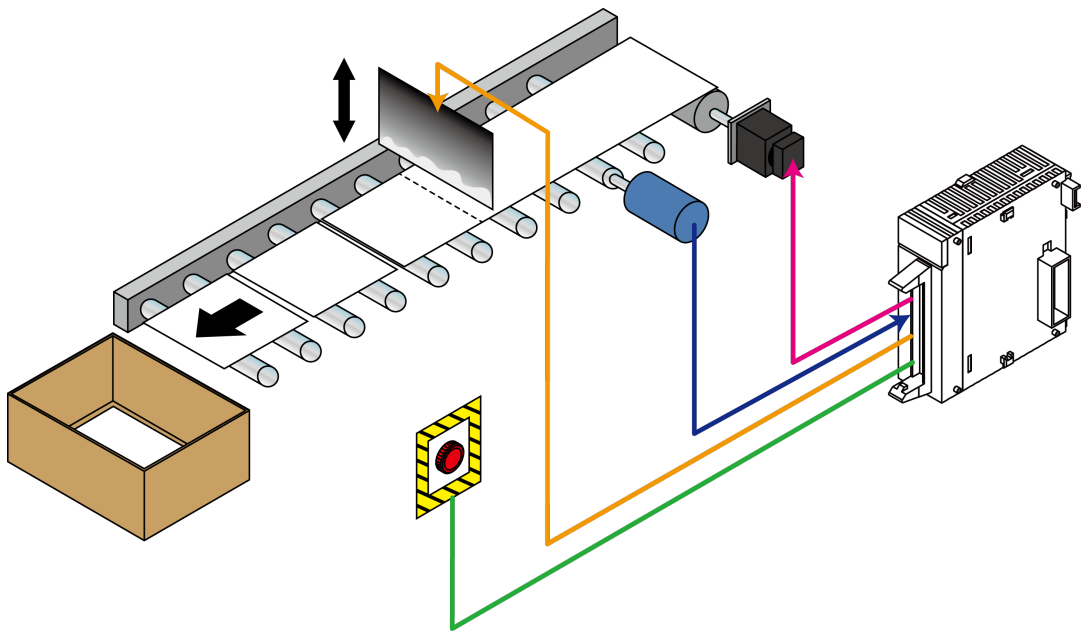

■ Inputs and outputs allocated flexibly

- As sixteen inputs and sixteen outputs can be allocated to various functions according to purposes to be used, effective system configuration can be achieved.
- Voltage detection circuits are built in the inputs and they recognize input voltage automatically. Any of the voltages of 24 VDC, 12 VDC and 5 VDC can be used.
- For outputs, the MOSFET of both Pch and Nch is adopted, and they can be used in any of the modes, sink output, source output, push-pull output (negative logic) and push-pull output (positive logic). When setting the push-pull output, a high-speed response can be obtained.

Input/Output	Allocated function
Input	Interrupt input: Max. 8 points High-speed counter: Max. 4 channels (Count input: 2 points, Reset input: 1 point, Mask input: 1 point) Input for positioning: Max. 4 channels ^(Note 1)
Output	Comparison match output: Max. 8 points Pulse output or PWM output: Max. 4 ch Positioning pulse output: Max. 4 ch

(Note 1) The positioning function is available only for the FP7 Multi I/O Unit (H type).

■ Equipped with various functions

One unit is equipped with the following functions.

1.1 Unit Functions and Operation

Function name	Overview
Interrupt	Besides the interrupt control by external inputs, the interrupt control by the comparison match with counter elapsed values is also available. High-speed response independent of scan time can be obtained.
Counter	The count method can be selected from direction distinction, individual input, and phase input. Frequencies can also be measured. An elapsed value hold function for storing the count value when a trigger occurs is provided. The count value independent of the scan time of PLC can be confirmed.
Comparison	The output can be obtained by comparing the counter elapsed value and an arbitrary value. It can be used as the output of multistage counter by optionally combining with counter channels.
Pulse output/PWM output	The pulse output function is provided which achieves an easy positioning control with one unit. The control by the PWM output is also be available. The counter for the pulse output/PWM output is equipped with four channels, and it can also be applied to operations such as switching the frequency at the time of constant pulse output or target value matched.
Positioning ^(Note 1)	User programs can be simplified by adopting the table setting. Positioning controls can be selected the following four patterns; E-point control, P-point control, C-point control and J-point control.

(Note 1) The positioning function is available only for the FP7 Multi I/O Unit (H type).

1.1.2 Unit Type and Product Number

■ Unit type and available functions

Product name	FP7 Multi Input/Output Unit	FP7 Multi Input/Output Unit H type
Product no.	AFP7MXY32DWD	AFP7MXY32DWDH
Interrupt Function	Available	Available
Counter Function	Available	Available
Comparison Output Function	Available	Available
Pulse Output/PWM Output Function	Available	Available
Positioning Function	-	Available

1.2 Restrictions on Units Combination

1.2 Restrictions on Units Combination

1.2.1 Restrictions by Power Consumption

The unit has the following internal current consumption. Make sure that the total current consumption is within the capacity of the power supply with consideration of all other units used in combination with this unit.

Name	Product no.	Current consumption
FP7 Multi Input/Output Unit	AFP7MXY32DWD	100 mA or less
FP7 Multi Input/Output Unit (H type)	AFP7MXY32DWDH	100 mA or less

1.2.2 Applicable Versions of FPCWIN GR7 and Units

For using the multi input/output unit, the following versions of FPCWIN GR7 and units are required.

Item	Applicable version
Programming tool software FPCWIN GR7	AFP7MXY32DWD Ver.2.10 or later AFP7MXY32DWDH Ver.2.12 or later
FP7 CPU Unit	CPS4* / CPS3*: Ver.1.2 or later, CPS2*: Ver.1.0 or later
FP7 Positioning Unit	For using the interrupt function with the multi input/output unit, the positioning unit ver.1.1 or later is required.

■ Procedure of confirming the unit version

Pressing the [[Unit information]] button in the ""Status display"" dialog box under "Online" of FPCWIN GR7 displays the unit version.

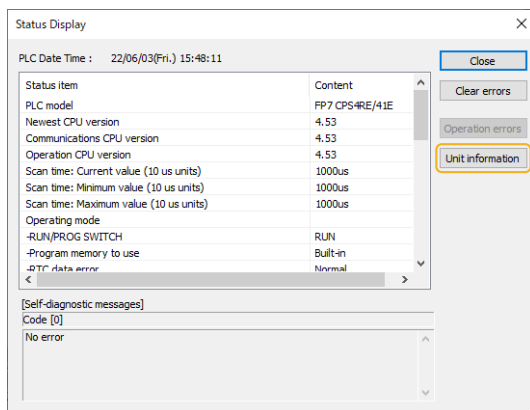

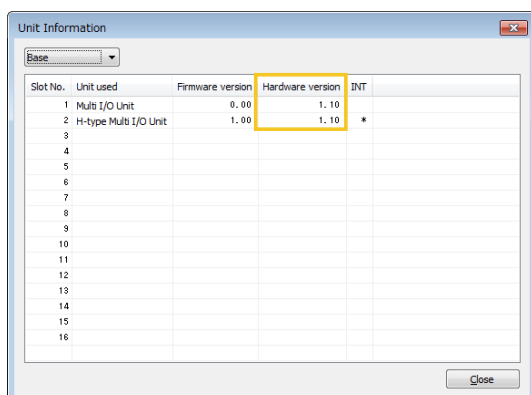

(Note 1) When an "*" is displayed in the INT column, it indicates that the mode setting switch on the side of the unit is set to "Use the interrupt function".

1.2.3 Restrictions on Interrupt Function

The multi input/output unit can start an interrupt program of the CPU unit using an interrupt input or counter comparison match flag. The interrupt function can be used within the following range.

■ Interrupt program specifications

Item		Specifications
No. of interrupt programs	Per multi I/O unit	Max. 8 programs
	Per CPU unit	Max. 64 programs (8 programs x 8 units)

(Note 1) If interrupts occur many times in one scan, the execution of interrupt program has priority, and the scan time will be longer.

(Note 2) If more than one interrupt activation request is made from the unit, the process will be carried out from the smallest slot number or the smallest interrupt program number.

1.2.4 Restrictions on I/O Allocation

- Any one of functions allocated to the same I/O number can be used. The inputs that are not allocated to any functions can be used as general inputs.
- Functions to be allocated are specified on the configuration dialog box of tool software FPWIN GR7. Allocate used input and output numbers not to be overlapped.

■ Input signal

Terminal number	I/O no.	Functions			
		Interrupt input	Counter	Counter elapsed value hold mode	Positioning
A1	X0	-	CH0 IN-A		CH0 Z

1.2 Restrictions on Units Combination

Terminal number	I/O no.	Functions			
		Interrupt input	Counter	Counter elapsed value hold mode	Positioning
A2	X1	-	CH0 IN-B		CH0 DOG
					CH0 JPOS
A3	X2	-	CH0 RST		CH0 LMT+
A4	X3	-	CH0 MASK		CH0 LMT-
A5	X4	-	CH1 IN-A		CH1 Z
A6	X5	-	CH1 IN-B		CH1 DOG
					CH1 JPOS
A7	X6	-	CH1 RST		CH1 LMT+
A8	X7	-	CH1 MASK		CH1 LMT-
B1	X8	INT0	CH2 IN-A	CH0 TRG	CH2 Z
B2	X9	INT1	CH2 IN-B	-	CH2 DOG
B3	XA	INT2	CH2 RST	-	CH2 LMT+
B4	XB	INT3	CH2 MASK	-	CH2 LMT-
B5	XC	INT4	CH3 IN-A	CH1 TRG	CH3 Z
B6	XD	INT5	CH3 IN-B	-	CH3 DOG
B7	XE	INT6	CH3 RST	-	CH3 LMT+
B8	XF	INT7	CH3 MASK	-	CH3 LMT+

(Note 1) Either DOG or JPOS is selectable.

Info.

- Interrupt inputs can be set by one point. A maximum of eight points can be set.
- For the counter function, four inputs are occupied per channel. (Counter input: 2 points, Reset input: 1 point, Mask input: 1 point)
- When using the counter elapsed value hold mode, one trigger input of the counter CH0 or CH1 is occupied.
- For the positioning function, four inputs are occupied per axis.
- The inputs that are not allocated to the interrupt input, counter or positioning function can be used as general external inputs. Also, when the interrupt inputs INT0 to INT7 are allocated to ""comparison match"", the corresponding inputs (X8 to XF) can be used as general external inputs.

■ Output signal

Terminal number	I/O no.	Functions			
		Comparison	Pulse output	PWM output	Positioning
A11	Y0	CMP0	-	-	-
A12	Y1	CMP1	-	-	-
A13	Y2	CMP2	-	-	-

1.2 Restrictions on Units Combination

Terminal number	I/O no.	Functions			
		Comparison	Pulse output	PWM output	Positioning
A14	Y3	CMP3	-	-	-
A15	Y4	CMP4	-	-	CH0 CLR
A16	Y5	CMP5	-	-	CH1 CLR
A17	Y6	CMP6	-	-	CH2 CLR
A18	Y7	CMP7	-	-	CH3 CLR
B11	Y8	-	PLS0 A	PWM0	PLS0 A
B12	Y9	-	PLS0 B	-	PLS0 B
B13	YA	-	PLS1 A	PWM1	PLS1 A
B14	YB	-	PLS1 B	-	PLS1 B
B15	YC	-	PLS2 A	PWM2	PLS2 A
B16	YD	-	PLS2 B	-	PLS2 B
B17	YE	-	PLS3 A	PWM3	PLS3 A
B18	YF	-	PLS3 B	-	PLS3 B

Info.

- Comparison outputs can be set by one point.
- A maximum of eight points can be set. The pulse output/PWM output function can be set for a maximum of four channels.
- The outputs that are not allocated to the comparison output, pulse output/PWM output or positioning function can be used as general external outputs. Also, when selecting the PWM output, the outputs (Y9, YB, YD, YF) can be used as general external outputs.

(MEMO)

2 Names and functions of parts

2.1 Names and functions of parts	2-2
2.1.1 Names and functions of parts	2-2
2.1.2 Operation monitor LEDs	2-2
2.1.3 Mode setting switches.....	2-3

2.1 Names and functions of parts

2.1 Names and functions of parts

2.1.1 Names and functions of parts

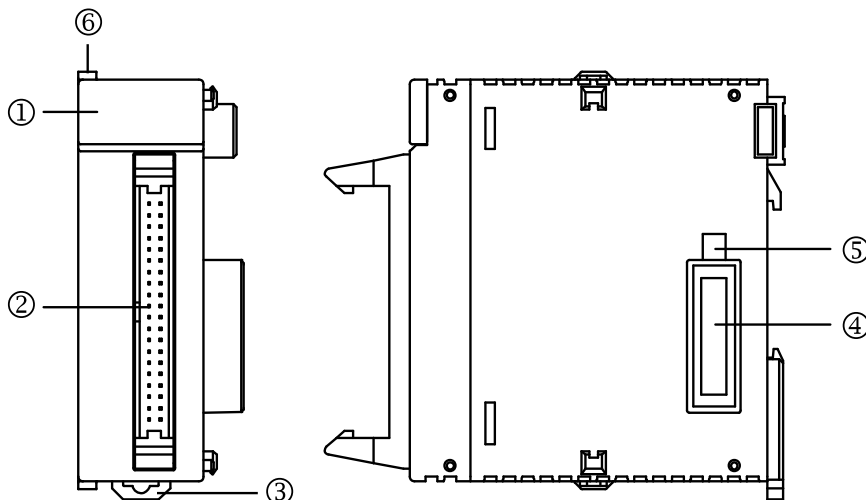

■ Names and functions of parts

No.	Name	Functions
(1)	Operation monitor LEDs	Indicates the operation mode, error occurrence state and input and output states. For details, refer to ""2.1.2 Operation monitor LEDs"".
(2)	I/O connector	Connector for input and output. (40-pin) (Conforms to MIL standard.)
(3)	DIN hook	This hook is used to install the unit on a DIN rail.
(4)	Unit connector	Connects the internal circuits between units.
(5)	Mode setting switches	Change the switch to use the interrupt function. At the factory setting, all the switches are off (the setting not to use the interrupt function). For details, refer to ""2.1.3 Mode setting switches"".
(6)	Fixing hook	This hook is used to fix units.

2.1.2 Operation monitor LEDs

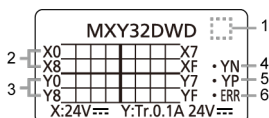

LED	Content	Color	LED ON	LED OFF	LED Flashing
1	Power supply of the unit	Blue	ON	OFF	—

2.1 Names and functions of parts

	LED	Content	Color	LED ON	LED OFF	LED Flashing
2	X0-XF	Input signal monitor ^(Note 1) ^(Note 2)	Green	Displays the status of the input signal.		
3	Y0-YF	Output signal monitor ^(Note 1)	Green	Displays the status of the output signal.		
4	YN	Output polarity display ^(Note 3) ^(Note 4)	Green	Turns on when there is an output that is set to ""Sink output"" or ""Push-pull output (negative logic)"".		
5	YP	Output polarity display ^(Note 3) ^(Note 4)	Green	Turns on when there is an output that is set to ""Source output"" or ""Push-pull output (positive logic)"".		
6	ERR	Alarm/Error/Warning occurrence display	Red	At the time of alarm/error occurrence	In normal operation	At the time of warning occurrence

(Note 1) The LEDs for the input and output both look as if they are continuously lit because the flashing speed is fast when the frequencies of signals are high.

(Note 2) The LED for each input signal indicates the status after input time constant processing.

(Note 3) The output polarity display switches according to the output polarity setting using the tool software or a program.

(Note 4) When the output polarity is not set by the software or program, both YN and YP will turn off. Also, when the settings of sink, source, push-pull (negative logic) or push-pull (positive logic) are mixed, the YN and YP turn on according to the polarity, and a warning occurs simultaneously.

2.1.3 Mode setting switches

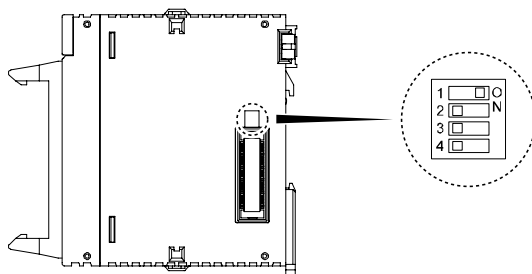

No.	Description
1	ON: Use the interrupt function, OFF: Not use the interrupt function
2	Not available. They should be always OFF.
3	
4	

(Note 1) At the factory setting, the mode setting switch number 1 is set to ""OFF"" (the setting not to use the interrupt function).

(MEMO)

3 Input/Output Specifications and Wiring

3.1 Input/Output Specifications	3-2
3.1.1 Characteristics of Input/Output Circuits	3-2
3.1.2 I/O Terminal Layout Diagram	3-2
3.1.3 Output Specifications	3-5
3.2 Wiring of Input and Output	3-8
3.2.1 Common Precautions to Input and Output.....	3-8
3.2.2 Input Wiring.....	3-8
3.2.3 Output Wiring	3-9
3.3 Connection Using the Discrete-wire Connector	3-11
3.3.1 Specifications of Wire-pressed Terminal Cable	3-11
3.3.2 Wiring the Discrete-wire Connector	3-12
3.4 Connection Using the Push-In Connector	3-15
3.4.1 About Push-In Connector.....	3-15
3.4.2 Compatible Parts and Dedicated Tools.....	3-15
3.4.3 Wiring to Connector	3-15

3.1 Input/Output Specifications

3.1 Input/Output Specifications

3.1.1 Characteristics of Input/Output Circuits

The I/O circuits of the FP7 Multi I/O Unit incorporate the following mechanism. Make the setting of the actual inputs/outputs and the settings on the software be the same.

■ Input circuit

The multi I/O unit has a circuit for detecting an input voltage and switching the input impedance. This can be used at either 24 V, 12 V, or 5 V. The voltage mode is set by the software. The input current varies according to the input voltage.

■ Output circuit

A MOSFET is built in, and it can be used in any of the sink output, source output, push-pull (negative logic output) and push-pull (positive logic output) modes. The output mode is selected by the software.

3.1.2 I/O Terminal Layout Diagram

■ Terminal layout diagram

The input is allocated to the upper 20 pins (A1 to A10/B1 to B10) of the connector, and the output is allocated to the lower 20 pins (A11 to A20/B11 to B20).

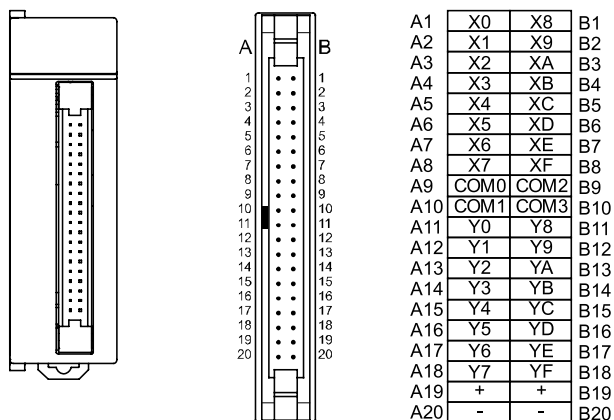

External connection diagram

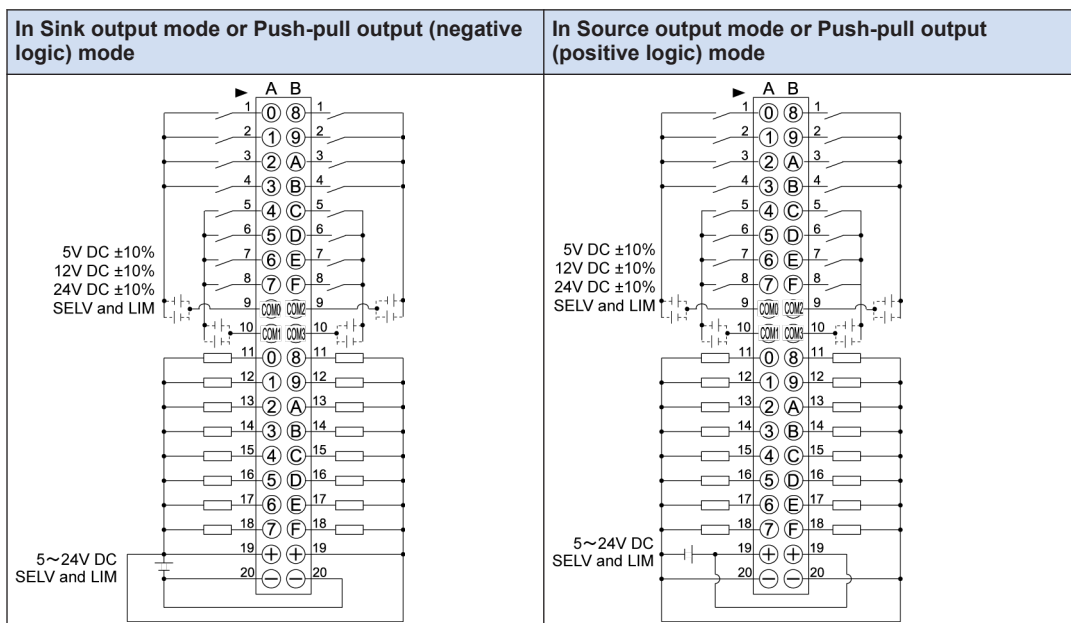

(Note 1) COM0 to COM3 are independent common terminals. They are not internally connected.

(Note 2) The two plus terminals (A19 and B19) on the output side are connected internally, and the two minus terminals (A20 and B20) are connected internally.

(Note 3) The voltages of the external power supply of the output circuit and the power supply for the load circuit should be within the range of 5 to 24 V.

Input Specifications

Item	Specifications	
	5 - 24 V mode	12 - 24 V mode
Insulation system	Digital isolator	
Rated input voltage	5 V / 12 V / 24 V DC ^(Note 1)	
Rated input current	Approx. 2 mA to approx. 10 mA (It automatically varies according to the input voltage.)	
Input impedance	Approx. 0.5 kΩ to approx. 4.3 kΩ (It automatically varies according to the input voltage.)	
Operating voltage range	±10% of each voltage	
Min. ON voltage/Min. ON current	4.2 V / 3 mA	7.5 V / 3 mA
Min. OFF voltage/Min. OFF current	2.8 V / 1 mA	5.0 V / 1 mA
Response time	OFF→ON	1.0 μs or less (at 5 V DC) 0.5 μs or less (at 12 V DC) 0.5 μs or less (at 24 V DC)

3.1 Input/Output Specifications

Item	Specifications	
	5 - 24 V mode	12 - 24 V mode
	ON→OFF	1.0 μ s or less (at 5 V DC) 2.0 μ s or less (at 12 V DC) 3.5 μ s or less (at 24 V DC)
Min. input pulse width		1.0 μ s (at 5 V/12 V DC) 2.0 μ s (at 24 V DC)
Input time constant setting		0, 0.5 μ s/1 μ s/1.5 μ s/2 μ s/4 μ s/8 μ s/16 μ s/32 μ s/64 μ s/96 μ s/128 μ s/256 μ s/ 2 ms/4 ms/8 ms ^(Note 2)
Output points per common		4 points/1 common (\pm common)

(Note 1) The mode of input voltage is selected by software. The default is the 5-24 V mode.

(Note 2) The default value of input time constant is 2 μ s.

■ Limitations on number of simultaneous input on points

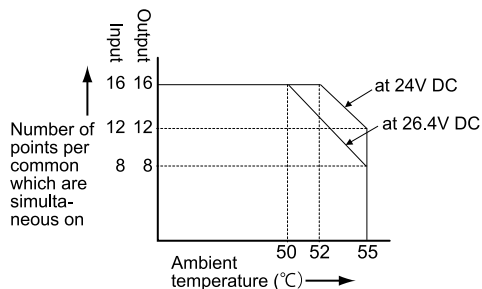

(Note 1) There is no limitation on the number of simultaneous on points in the ambient temperature range between 0 to 55°C when using 12 V DC or 5 V DC.



- Use the input voltage within $\pm 10\%$ of 5 V, 12 V or 24 V. Heat or chattering may be generated when using a voltage out of this range.

■ Internal circuit diagram and external connection diagram

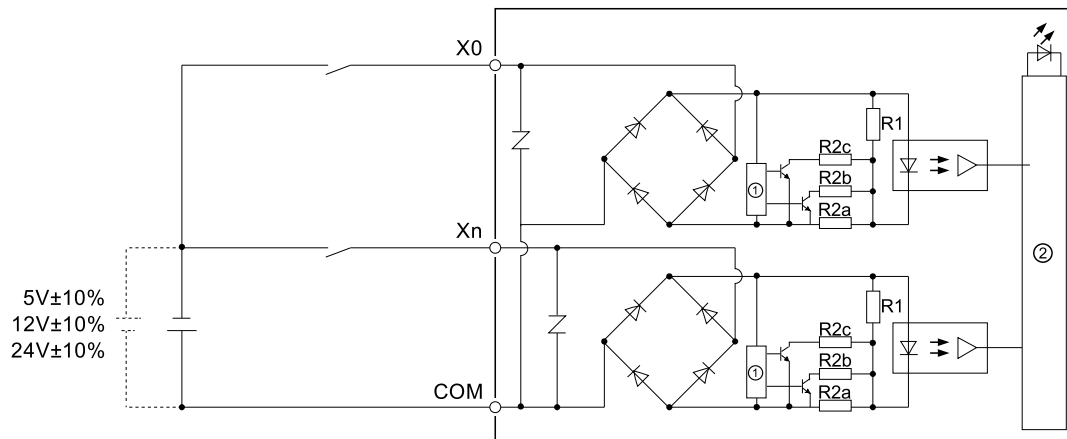

R1 = 10 k Ω , R2a = 4.3 k Ω , R2b = 5.6 k Ω , R2c = 510 Ω

(1) Voltage detection circuit	(2) Internal circuit
-------------------------------	----------------------

■ Characteristics of input circuit

- The multi I/O unit has a circuit for detecting an input voltage and switching an input impedance. See the following table as a guide for input impedances when using each voltage.

Voltage	Input impedance
5 V	$1 / \{ (1/4.3 \text{ k}\Omega) + (1/5.6 \text{ k}\Omega) + (1/510 \text{ }\Omega) \} \approx 420 \text{ }\Omega$
12 V	$1 / \{ (1/4.3 \text{ k}\Omega) + (1/5.6 \text{ k}\Omega) \} \approx 2.43 \text{ k}\Omega$
24 V	4.3 k Ω

- Input impedances are switched in three stages in the 5-24 V mode, and in two stages in the 12-24 V mode. Input currents vary like the following graphs. The respective minimum ON voltages and maximum OFF voltages in the 5-24 V mode and 12-24 V mode are different.

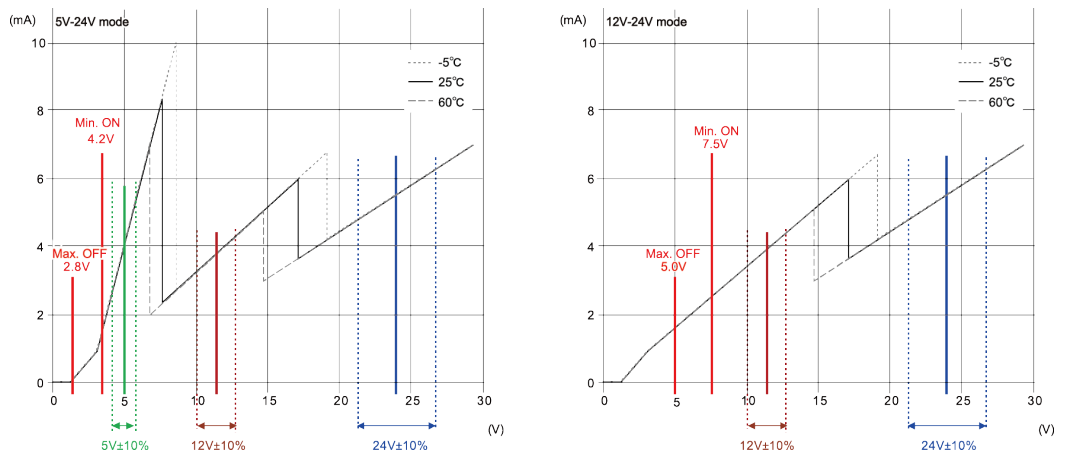

3.1.3 Output Specifications

Item	Specifications	
Insulation system	Digital isolator	
Output device	MOSFET	
Output method ^(Note 1)	Nch open drain / Pch open drain / Push-pull	
Rated load voltage	5 V DC to 24 V DC	
Allowable load voltage range	4.75 V DC to 26.4 V DC	
Max. load current	0.1A	
Off state leakage current	3.0 μ A or less	
ON Max. voltage drop	1.0 V DC or less	
Response time	OFF→ON	0.5 μ s or less ^(Note 2)
	ON→OFF	0.5 μ s or less ^(Note 2)
External power supply	Voltage	4.75 V DC to 26.4 V DC

3.1 Input/Output Specifications

Item		Specifications
	Current	100 mA or less
Output points per common		16 points/common (common to external power supply terminals)
Surge absorber		Zener diode
Operating mode indicator		LED display

(Note 1) The output method is selected by the software. The both polarities are off at the time of startup. The output polarity must be set.

(Note 2) This shows the response time when the push-pull method is set and the output current is 0.1 A. It varies according to the setting of the output method and load.

(Note 3) The voltages of the external power supply for the output circuit and the power supply for the load circuit should be within the range of 5 to 24 V. When supplying power for the external power supply and that for the load circuit from other power supplies, the load circuit voltage (V2) must be the same as or smaller than the external supply voltage (V1). When the load circuit voltage (V2) is larger than the external supply voltage (V1), the current flows back as below.

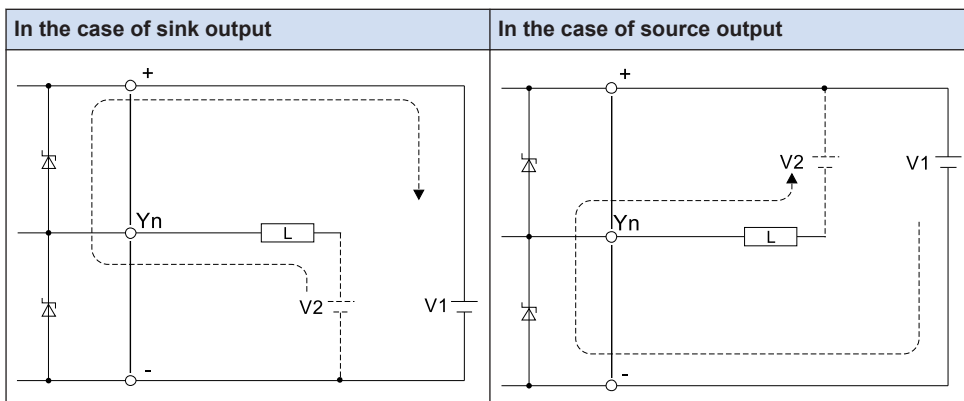

■ Internal circuit diagram and external connection diagram

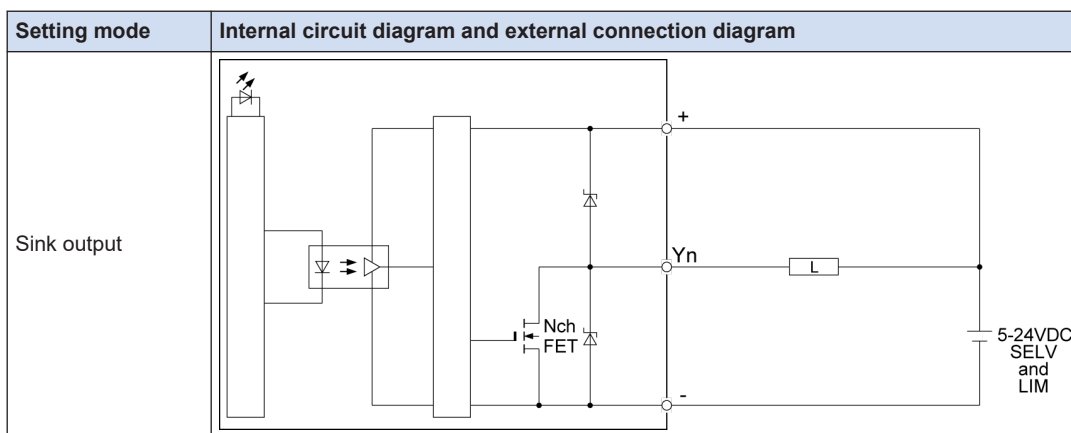

3.1 Input/Output Specifications

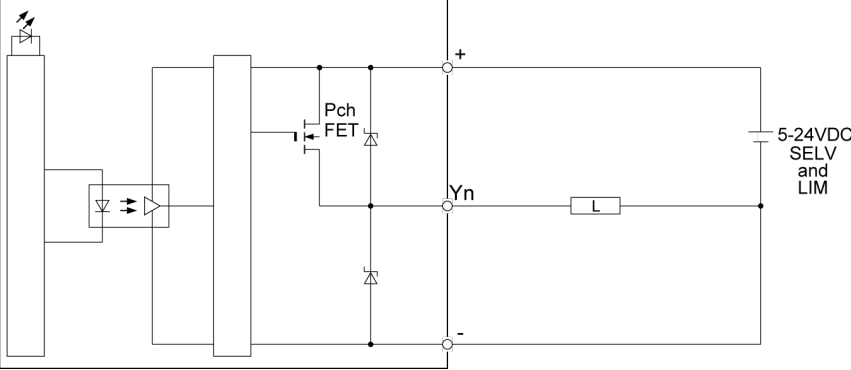
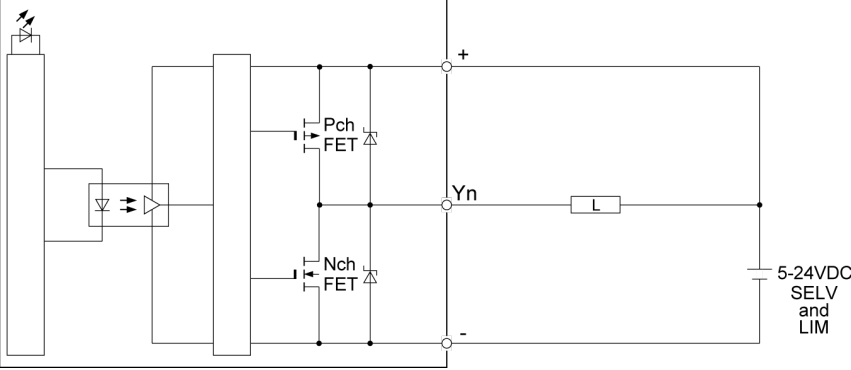
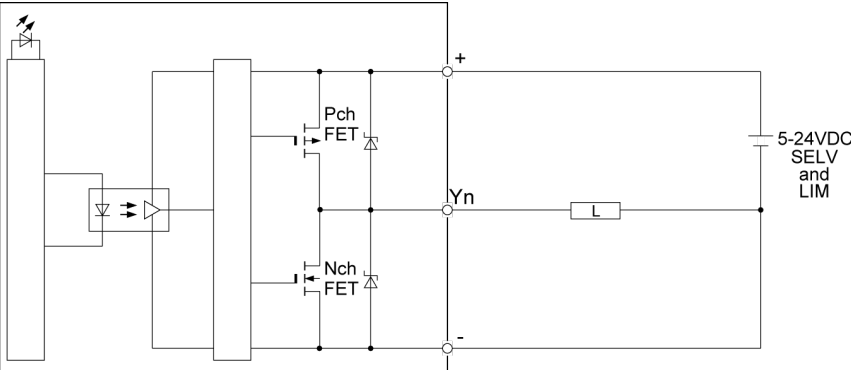
Setting mode	Internal circuit diagram and external connection diagram
Source output	
Push-pull Negative logic output	 <p data-bbox="401 1035 1249 1081">When the operation result output Y is 1, the Pch turns off and Nch turns on, and energization to the load is performed.</p>
Push-pull Positive logic output	 <p data-bbox="401 1470 1249 1516">When the operation result output Y is 1, the Pch turns on and Nch turns off, and energization to the load is performed.</p>

3.2 Wiring of Input and Output

3.2 Wiring of Input and Output

3.2.1 Common Precautions to Input and Output

■ Wiring position

Arrange the wiring so that the input and output wiring are separated, and these wirings are separated from the power wiring, as much as possible. Do not route them through the same duct or tie them in a bundle. Separate the input/output wires from the power and high voltage wires by at least 100 mm.

■ Selection of wires

Be sure to select the thickness (dia.) of the input and output wires while taking into consideration the required current capacity.

■ Power supply

Wiring should be performed after the power supply to the PLC is turned off. Performing this while the power supply is on may cause an accident, fault or malfunction.

3.2.2 Input Wiring

The following figures show the case when they are connected with the + common.

■ Connection of photoelectric sensor and proximity sensor

Relay output type

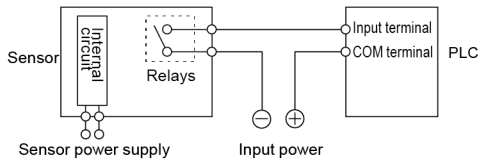

NPN open collector output type

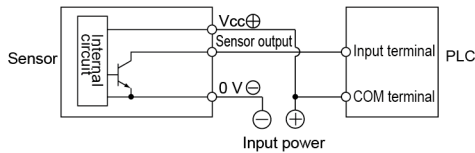

Voltage Output Type

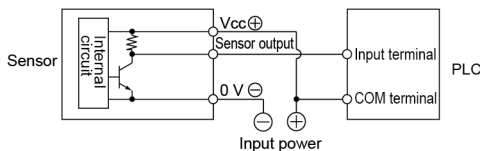

Two-wire output type

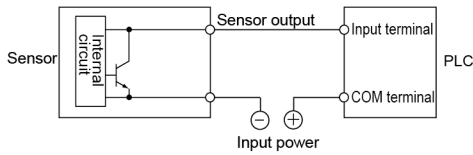

■ **Precaution when Using LED-equipped Lead Switch**

When an LED is connected in series to an input contact such as an LED-equipped lead switch, make sure that the voltage applied to the PLC input terminal is greater than the ON voltage. In particular, take care when connecting a number of switches in series.

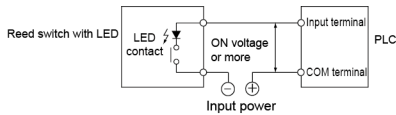

■ **Precaution when Using Two-wire Type Sensor**

If input to the PLC does not turn off because of leakage current from a two-wire type photoelectric sensor or a proximity sensor, connecting a bleeder resistor is recommended, as shown below.

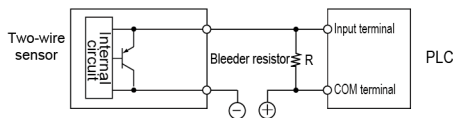

■ **Precaution when Using LED-equipped Limit Switch**

If the input of PLC does not turn off because of leakage current from the LED-equipped limit switch, the use of a bleeder resistor is recommended, as shown below.

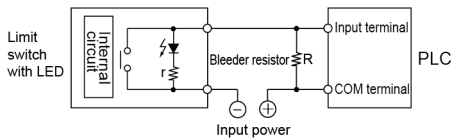

3.2.3 Output Wiring

The following figures show the case when they are connected with the sink output.

■ **Protective circuit for inductive loads**

With an inductive load, a protective circuit should be installed in parallel with the load.

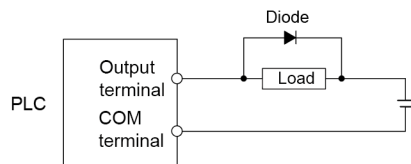

Diode Reverse voltage Higher than 3 times the rated load voltage
Average rectified current Greater than the load current

3.2 Wiring of Input and Output

■ Precautions when using capacitive loads

When connecting loads with large in-rush currents, to minimize their effect, connect a protection circuit as follows.

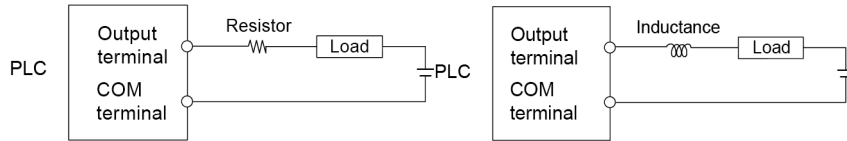

3.3 Connection Using the Discrete-wire Connector

No discrete-wire connector is provided with the unit. Purchase it separately.

3.3.1 Specifications of Wire-pressed Terminal Cable

This is a connector allowing loose wires to be connected without removing the wire's insulation. A pressure connection tool is required to connect the loose wires.

Connector for wire-pressed terminal cable (40P)

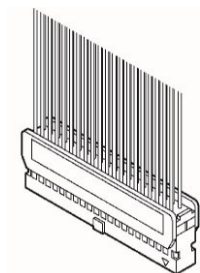

■ Suitable wires (strand wire)

Size	Nominal cross-sectional area	Insulation thickness	Rated current
AWG22	0.3 mm ²	Φ1.5 to Φ1.1	3A
AWG24	0.2 mm ²		

■ Connector AFP2801 for wire-pressed terminal cable (provided with unit)

Composition of parts	Required quantity
Housing (40P)	1 x 1 set
Semi-cover (40P)	2 x 1 set
5-pin contact (for AWG22 and 24)	8 x 1 set

(Note 1) One set is provided for the product. If you need more connectors, purchase AFP2801 (2 sets/pack).

■ Dedicated pressure welding tool

Product no.	AXY52000FP
-------------	------------

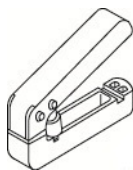

3.3 Connection Using the Discrete-wire Connector

3.3.2 Wiring the Discrete-wire Connector



- When performing wiring work, refer to the instruction manual of the crimping tool in order to prevent faulty wiring.

1₂

Procedure

1. Bend and break the contact, and set it in the crimping tool.

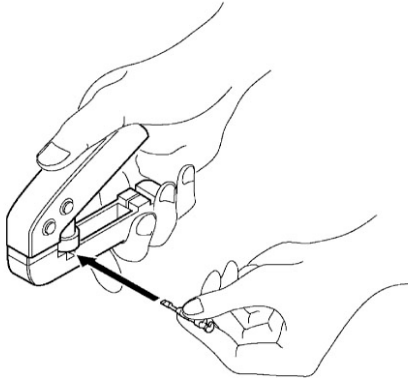

2. Insert the wire without removing its insulation until it stops, and lightly grip the crimping tool.

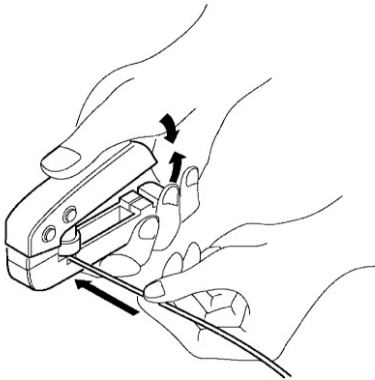

3. The contact appears as shown below after it is crimped. Confirm the following two points.
 1. The wire must be embraced inside the clamped part.
 2. The wire must be inserted to the end.

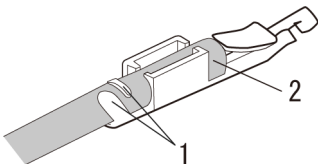

4. Insert the wire with the contact into the housing.

3.3 Connection Using the Discrete-wire Connector

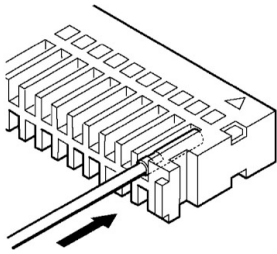

5. When all the wires have been inserted, fit the semi-cover into place.

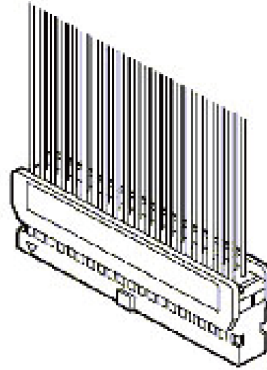
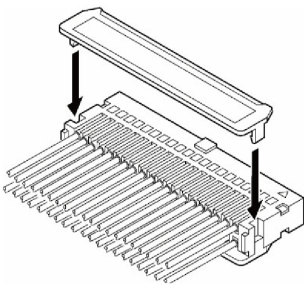

3.3 Connection Using the Discrete-wire Connector

i Info.

- If there is a wiring mistake or the wire is incorrectly press-fit, use the crimping tool to remove the contact.
 1. Set the pin of the crimping tool at the position indicated by an arrow.

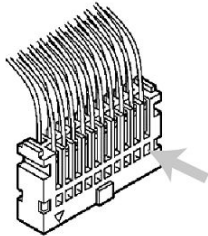

2. Hold the housing with fingers and pull the wire.

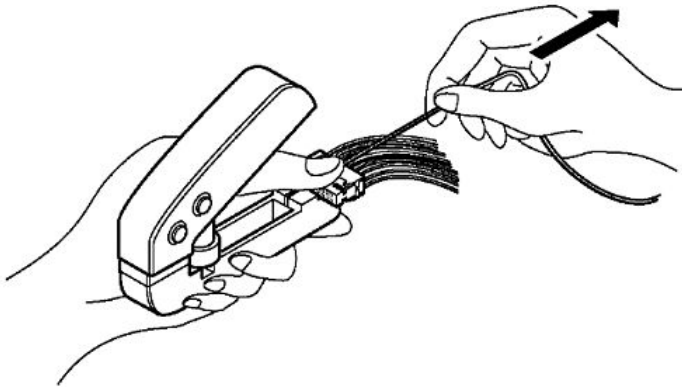

3.4 Connection Using the Push-In Connector

3.4.1 About Push-In Connector

40-pole push-in type connector manufactured by Ningbo Degson Electronic Co. Ltd. that can be used with the FP7 Series.

Product name	Model number	Remarks
Push-in connector set (40-pole)	AFP2808	2 pcs.

3.4.2 Compatible Parts and Dedicated Tools

Pole terminal with insulating sleeve

Use the following pole terminals.

Manufacturer	Model number	Size	Cross-sectional area
Phoenix Contact Co. Ltd	AI0, 34-8TQ	AWG#22	0.34 mm ²

Dedicated pressure-welding tool for pole terminals

Manufacturer	Model number
Phoenix Contact Co. Ltd	CRIMPFOX 10S

3.4.3 Wiring to Connector

Installing onto the Unit

Follow the procedure below to install the product onto the unit.

1 Procedure

1. Open out the clasps of the MIL connector.

3.4 Connection Using the Push-In Connector

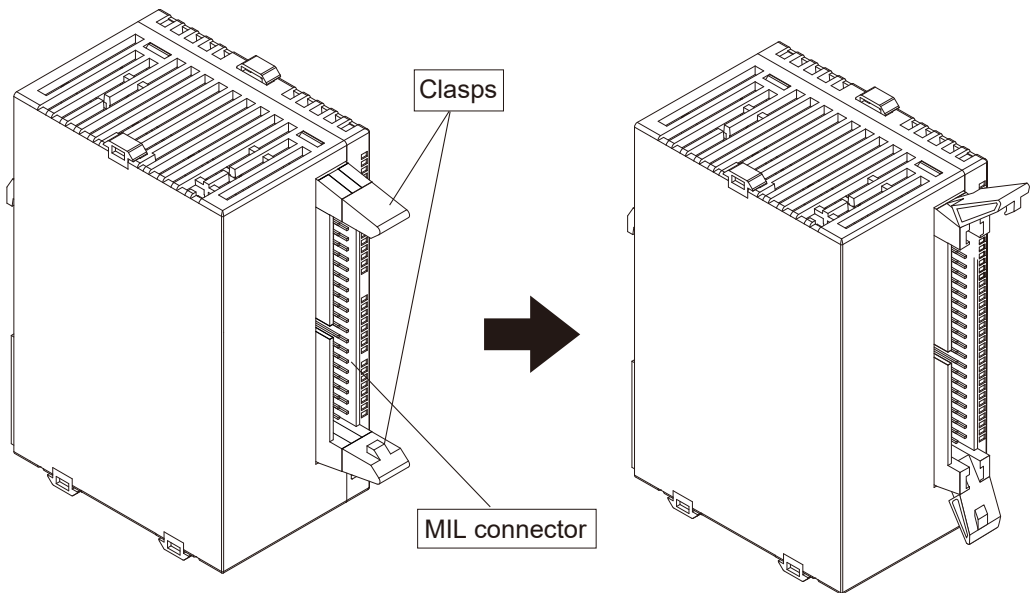

2. Insert the product into the MIL connector. When inserting the product, make sure that the triangular marking is at the top.

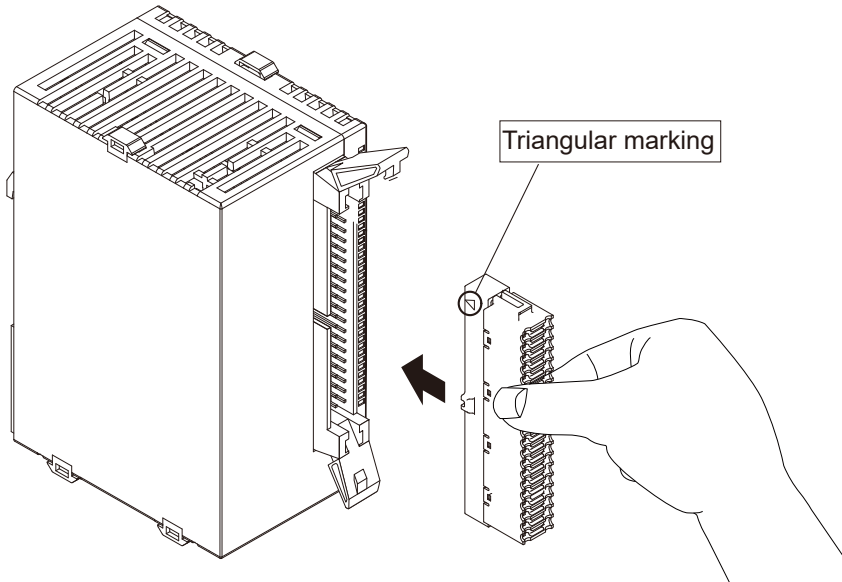

3. Insert the product until the clasps of the MIL connector close.

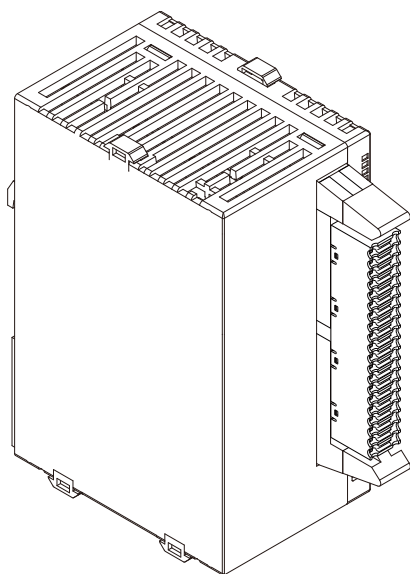

Wiring

Follow the procedure below when wiring.

Note

Wiring precautions

- Do not damage the core when stripping off the covering material.
- Do not apply stress to the wires after wiring.
- Do not solder the core. Soldering the core may cause it to disconnect due to vibration.

1 2 Procedure

1. Strip off the covering material from the wire



2. Attach the pole terminal to the core part. Do not twist the core when attaching.



3. After attaching the pole terminal, pressure-weld using the dedicated pole terminal pressure-welding tool.
4. After pressure-welding, insert the wire into the product.

3.4 Connection Using the Push-In Connector

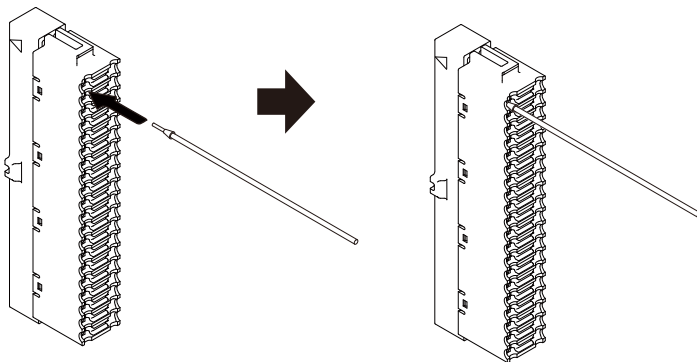

i Info.

After inserting the wire, ensure that the wire does not protrude.

Replacing Wires

Follow the procedure below when replacing wires.

1 2 Procedure

Use the following dedicated tool or an equivalent flat-head screwdriver to remove the wire.

Dedicated tool

Manufacturer	Model number	Remarks
Phoenix Contact Co. Ltd	SZS 0, 4x2, 5	Blade width 0.4 × Blade thickness 2.5

1. Push the dedicated tool or flat-head screwdriver into the release button on the product.

3.4 Connection Using the Push-In Connector

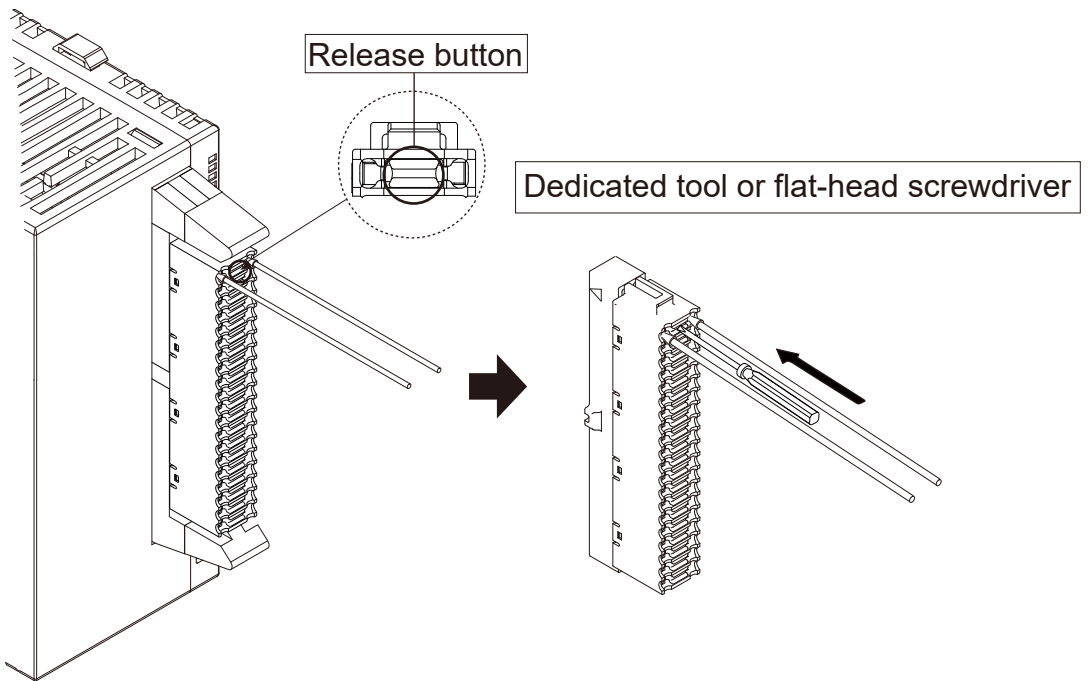

2. Remove the wire while pressing down the button.

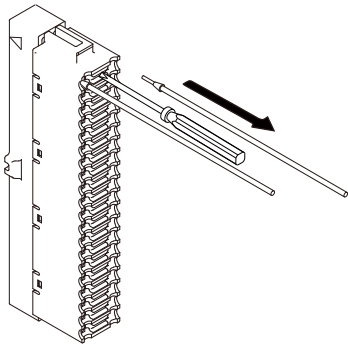

3. Insert the new wire. For details on how to insert the wire, refer to "Wiring".

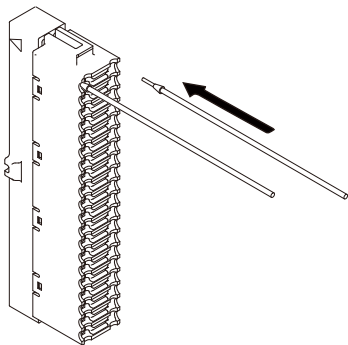

3.4 Connection Using the Push-In Connector

Info.

- Pressing the release button unlocks the wires on both sides of the button. After replacing the wires, ensure that the wires do not protrude.

Removing from the Unit

Follow the procedure below to remove the product from the unit.

1 2 Procedure

1. Open out the clasps of the MIL connector.

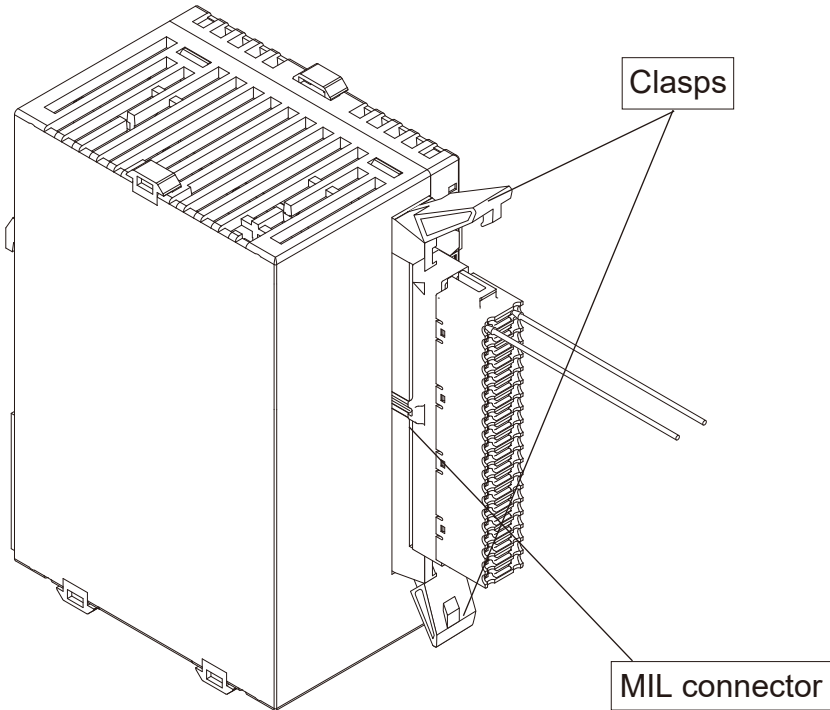

2. Remove the product from the unit.

3.4 Connection Using the Push-In Connector

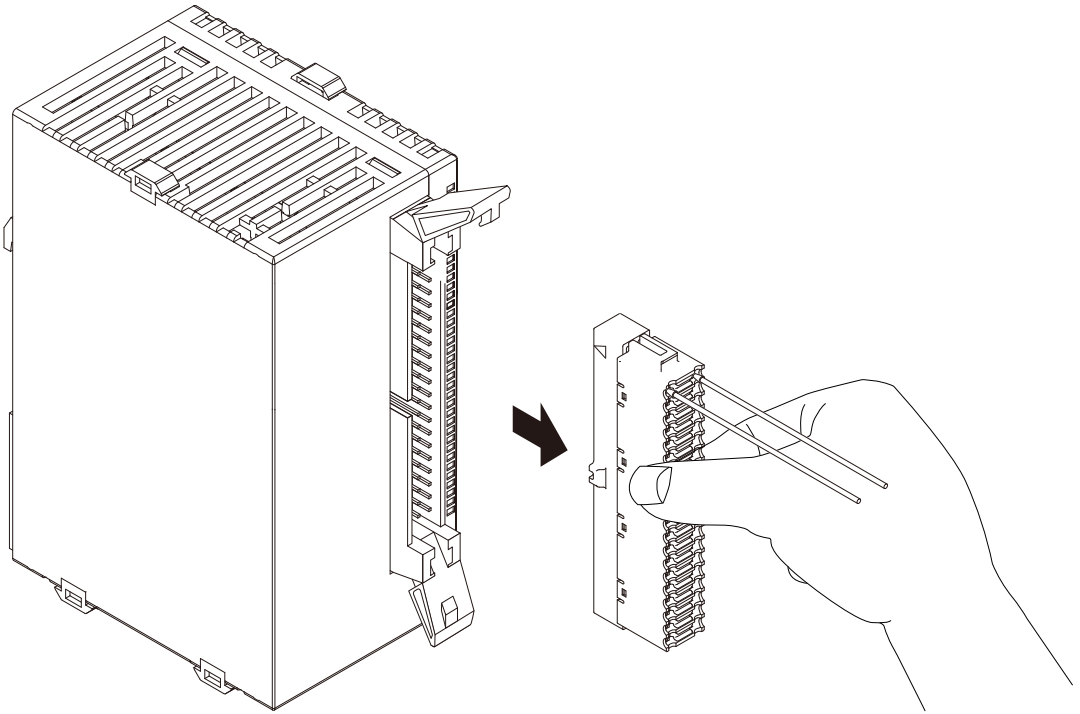

4 Unit Allocation

4.1 Unit Allocation	4-2
4.1.1 Number of Occupied I/O Points for the Unit.....	4-2
4.1.2 Confirmation of I/O Allocation Information	4-2
4.1.3 Registration in I/O Map	4-3

4.1 Unit Allocation

4.1 Unit Allocation

4.1.1 Number of Occupied I/O Points for the Unit

The input and output starts from the same I/O numbers in FP7 series. For the multi I/O unit, the following number of words is occupied.

Product number	Name	Input	Output
AFP7MXY32DWD	FP7 Multi Input/Output Unit	4 words (64 points)	4 words (64 points)
AFP7MXY32DWDH	FP7 Multi Input/Output Unit (H type)	6 words (96 points)	6 words (96 points)

4.1.2 Confirmation of I/O Allocation Information

The following I/O contacts are allocated for the multi I/O unit. The external inputs and external outputs that are not allocated to any functions can be used as general inputs and outputs.

■ Input contact

Item	I/O no.	Functions
External input	X0-X7	Counter (Input, reset mask) or positioning input
	X8-XF	Interrupt input or counter (Input, reset, mask) or positioning input
For control Internal input	X10-X17	Comparison contact monitor
	X18-X1F	Pulse output / PWM output monitor
	X20-X27	Counter (Overflow flag, underflow flag)
	X28-X2F	(Reserved for system)
	X30-X3B	Positioning (Busy flag, operation done flag, home return done flag)
	X30-X3F	(Reserved for system)

(Note 1) The I/O numbers actually allocated are based on the first word number allocated to the unit.

Example) When the starting word number for the unit is ""10"", input contacts are numbered starting from X100.

■ Output contact

Item	I/O no.	Functions
External output	Y0-Y7	Comparison output or positioning (Deviation counter clear)
	Y8-YF	Pulse output / PWM output or positioning (Pulse output CW/CCW or pulse output)
For control Internal output	Y10-Y17	Counter (Softwrae reset, mask), counter hold function (Enable, input logic)
	Y18-Y1F	Pulse output / PWM output (Enable, start)
	Y20-Y27	Counter (Overflow clear, underflow clear)
	Y28-Y2F	Pulse output (Direction), pulse output counter (Reset)
	Y30-Y34	Positioning (Positioning table start, positioning simultaneous start)
	Y35-Y37	(Reserved for system)

Item	I/O no.	Functions
	Y38-Y3B	Positioning (Home return start)
	Y3C-Y43	Positioning (JOG operation start Forward/Reverse)
	Y44	Positioning (System stop)
	Y45-Y47	(Reserved for system)
	Y48-Y4F	Positioning (Emergency stop, deceleration stop)
	Y50-Y55	Positioning (J-point control positioning start input, near home input, J-point control speed change)
	Y56	Positioning (Error clear)
	Y57-Y5F	(Reserved for system)

(Note 1) The I/O numbers actually allocated are based on the first word number allocated to the unit.

Example) When the starting word number for the unit is ""10"", output contacts are numbered starting from Y100.

Info.

- For details of I/O allocation information, refer to ""13.2 Allocation of I/O Numbers"".

4.1.3 Registration in I/O Map

Before setting parameters, register the unit to be used in the I/O map. The following procedure shows an example when FPWIN GR7 has been started and the CPU unit has been already registered as the slot number 0 and the multi I/O unit is allocated to the slot number 1.

1 2 Procedure

1. Select **Options>FP7 Configuration>I/O map** in the menu bar.
The "I/O Map Setting" dialog box is displayed.
2. Double-click a desired slot.
The "Unit Selection" dialog box is displayed.
3. Select the unit name to use in the "Select unit to use" field, and press the **[[OK]]** button.

4.1 Unit Allocation

Unit selection [Slot No. 1]

Select unit to use: _____

Unit type: Multi I/O

Unit name: Multi I/O Unit

Input time constant: 0

Installation location setting

Starting word No. 10 (0 - 511)

Number of input words: 4 (0 - 128)

Number of output words: 4 (0 - 128)

Option

Exclude this unit from the target for verification.

Exclude this unit from the target for I/O refresh.

The selected unit is now registered in the I/O map.

The following figure shows the case that the input and output units have been registered subsequently. The multi I/O unit occupies four words each for input and output.

I/O map

Select Power Supply Unit/Expansion Unit

Power Supply Unit: 24V DC

Expansion unit: Not used

Expansion unit startup wait time: 5 Seconds (5 - 1800)

Max. consumption: 3.0 A
Total: 0.4 A
Remaining: 2.6 A

Unit maximum registered capacity: 1.20 MB
Remaining registered capacity: 1.20 MB

Slot No.	Product No.	Unit used	Head	Input	Outp...	Veri...	Refresh	Time ...	Consum...	Cassette	Programmabl...
<input type="checkbox"/>	0	AFP7CPS41E	FP7 CPU unit	0	10	10	Valid	Valid	200mA	Not registered	Not registered
<input checked="" type="checkbox"/>	1	AFP7MXY32DW	Multi I/O Unit	10	4	4	Valid	Valid	100mA		
<input type="checkbox"/>	2	AFP7X32D2	Input unit (DC type),	14	2	0	Valid	Valid	0	30mA	
<input type="checkbox"/>	3	AFP7Y32T	Output unit (sink typ.	16	0	2	Valid	Valid	50mA		
<input type="checkbox"/>	4										
<input type="checkbox"/>	5										

5 Multi I/O Unit Setting

5.1 Basic Setup.....	5-2
5.1.1 Basic setting item.....	5-3
5.2 Output Terminal Setting	5-4
5.2.1 Overview	5-4
5.2.2 Allocation of Contacts to Output Terminals	5-5
5.2.3 Application to Differential Output.....	5-6
5.3 Application Setting	5-9
5.3.1 Overview	5-9
5.3.2 Setting Items by Use.....	5-9

5.1 Basic Setup

5.1 Basic Setup

The settings of the multi I/O unit are specified in the configuration menu of FPWIN GR7. The input voltage mode, input time constant and output polarity can be switched by the setting of the software. The default setting for the output is "Output OFF". Set this as appropriate.

1 2 Procedure

1. Select **Options>Multi I/O Unit Setting** in the menu bar.
2. Select the type of Multi I/O Unit.

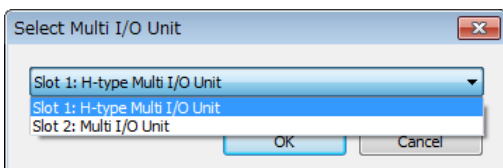

The basic setup screen of "Multi I/O Unit Setting" is displayed.

3. Set each item of the basic setup.

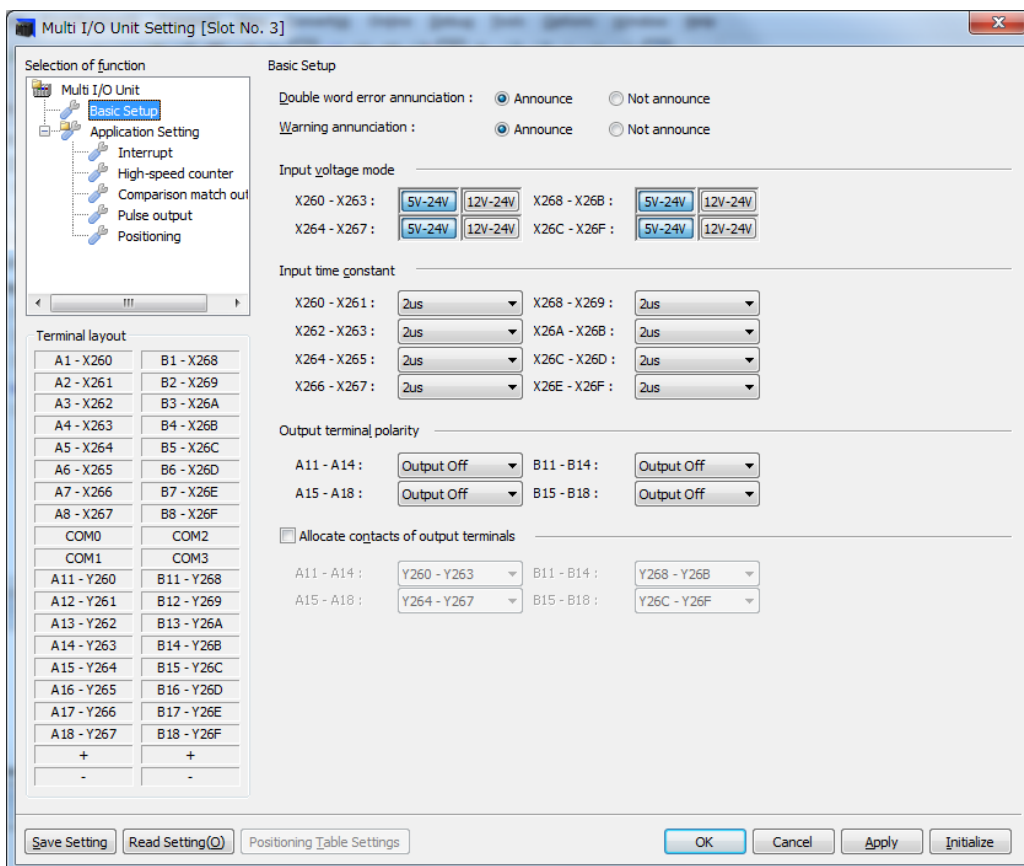

5.1.1 Basic setting item

Setting item	Default	Settings	Related page
Double word error annunciation	Announce	Set whether or not to announce a double word access error when it occurs. Announce/Not announce	"P.12-4"
Warning annunciation	Announce	Set whether or not to announce a warning when it occurs. Announce/Not announce	"P.12-7"
Input voltage mode	5 V-24 V	Select either the 5V-24V mode or 12V-24V mode. The switching operation of the impedance of the input circuit, minimum ON voltage and maximum ON voltage vary according to the selected mode.	"P.3-3"
Input time constant	2 μ s	0 / 0.5 μ s / 1 μ s / 1.5 μ s / 2 μ s / 4 μ s / 8 μ s / 16 μ s / 32 μ s / 64 μ s / 96 μ s / 128 μ s / 256 μ s / 2ms / 4ms / 8ms	"P.3-3"
Output terminal polarity	Output Off	The output circuit is switched. Select to match the actual wiring. Output OFF: Output OFF Sink output: N channel output Source output: P channel output N push-pull: Push-pull (negative logic) P push-pull: Push-pull (positive logic)	"P.3-5"

(Note 1) The parameters of the basic setup are set for the external terminal regardless of the selection contents of functions.

■ Precautions when using FPWIN GR7 for configuration

When using the GR7 ver.2.12 or later on the Multi I/O Unit ver.1.0x, there are the following restrictions.

- On the Multi I/O Unit ver.1.0x, the setting of the double word error annunciation specified by the FPWIN GR7 is not reflected. It can be set using a program. Refer to "[13.4.1 Alarm/Error/Warning](#)".
- On the Multi I/O Unit Ver.1.0x, the following values specified for input time constants by the FPWIN GR7 are set as 2 μ s.
0.5 μ s/1.5 μ s/32 μ s/64 μ s/96 μ s/128 μ s/256 μ s/8 ms
It can be set using a program. Refer to "[13.4.2 Input setting](#)".

5.2 Output Terminal Setting

5.2 Output Terminal Setting

5.2.1 Overview

On Multi Input/Output Unit, the allocation of output terminal polarities and output numbers can be switched by the setting of the software.

- Output terminal polarities can be selected from sink, source, P-type push-pull (positive logic) and N-type push-pull (negative logic).
- ""Allocate contacts of output terminals"" is used when to allocate a single I/O signal to two output circuits. It is possible to apply them as line driver output by using this function.
- This setting can be made for four output circuits and four output points each.

■ Multi I/O Unit Setting dialog box

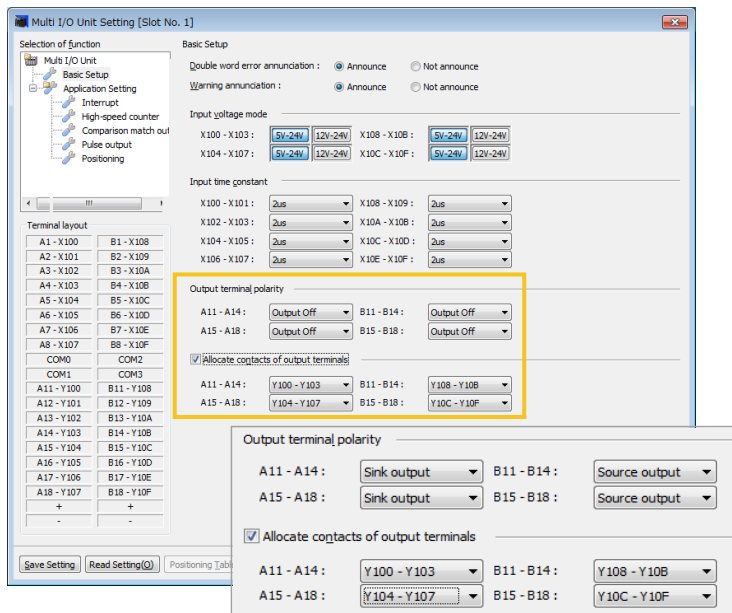

■ Example of Setting Output Terminal Polarity

- By default, ""Output OFF"" is selected.
- For using this like a general digital output unit, select ""Sink output"" for all points or ""Source output"" for all points in "Output terminal polarity".
- The output formats can be mixed by four circuits.

Example 1 of using sink and source outputs

Output terminal polarity

A11 - A14 : Sink output B11 - B14 : Source output

A15 - A18 : Sink output B15 - B18 : Source output

A1	X0	X8	B1
A2	X1	X9	B2
A3	X2	XA	B3
A4	X3	XB	B4
A5	X4	XC	B5
A6	X5	XD	B6
A7	X6	XE	B7
A8	X7	XF	B8
A9	COM	COM	B9
A10	COM	COM	B10
A11	Y0	Y8	B11
A12	Y1	Y9	B12
A13	Y2	YA	B13
A14	Y3	YB	B14
A15	Y4	YC	B15
A16	Y5	YD	B16
A17	Y6	YE	B17
A18	Y7	YF	B18
A19	+	+	B19
A20	-	-	B20

Example 2 of using sink and source outputs

Output terminal polarity

A11 - A14 : Sink output B11 - B14 : Source output

A15 - A18 : Source output B15 - B18 : Sink output

A1	X0	X8	B1
A2	X1	X9	B2
A3	X2	XA	B3
A4	X3	XB	B4
A5	X4	XC	B5
A6	X5	XD	B6
A7	X6	XE	B7
A8	X7	XF	B8
A9	COM	COM	B9
A10	COM	COM	B10
A11	Y0	Y8	B11
A12	Y1	Y9	B12
A13	Y2	YA	B13
A14	Y3	YB	B14
A15	Y4	YC	B15
A16	Y5	YD	B16
A17	Y6	YE	B17
A18	Y7	YF	B18
A19	+	+	B19
A20	-	-	B20

(Note 1) When the polarities are mixed, a warning occurs and the ERR LED on the unit flashes to remind users to check the wiring.

To disable warning announcement, set "Warning announcement" to "Not announce" in the "Multi I/O Unit Setting" screen of tool software FPWIN GR7. (Available since Ver.1.1.) Or, set bit 9 of UM00062 to 1.

5.2.2 Allocation of Contacts to Output Terminals

The contact allocation function to output terminals is a function to allocate Y contacts to output terminals by four points. The arrangement can be changed from the initial state and the same Y contact can be allocated to multiple terminals.

■ Example of contact allocation

In this example, "Output terminal polarity" is set to use sink and source outputs and the signals of A15-A18 are replaced with the signals of B11-B14.

5.2 Output Terminal Setting

Output terminal polarity

A11 - A14 : Sink output B11 - B14 : Source output

A15 - A18 : Source output B15 - B18 : Sink output

A1	X0	X8	B1
A2	X1	X9	B2
A3	X2	XA	B3
A4	X3	XB	B4
A5	X4	XC	B5
A6	X5	XD	B6
A7	X6	XE	B7
A8	X7	XF	B8
A9	COM	COM	B9
A10	COM	COM	B10
A11	Y0	Y8	B11
A12	Y1	Y9	B12
A13	Y2	YA	B13
A14	Y3	YB	B14
A15	Y4	YC	B15
A16	Y5	YD	B16
A17	Y6	YE	B17
A18	Y7	YF	B18
A19	+	+	B19
A20	-	-	B20

In this example, "Output terminal polarity" is set to use two kinds of push-pull outputs and the same Y contact is allocated to two output circuits.

Output terminal polarity

A11 - A14 : P-type push-pull B11 - B14 : P-type push-pull

A15 - A18 : N-type push-pull B15 - B18 : N-type push-pull

Allocate contacts of output terminals

A11 - A14 : Y108 - Y10B B11 - B14 : Y10C - Y10F

A15 - A18 : Y108 - Y10B B15 - B18 : Y10C - Y10F

A1	X0	X8	B1
A2	X1	X9	B2
A3	X2	XA	B3
A4	X3	XB	B4
A5	X4	XC	B5
A6	X5	XD	B6
A7	X6	XE	B7
A8	X7	XF	B8
A9	COM	COM	B9
A10	COM	COM	B10
A11	Y8	YC	B11
A12	Y9	YD	B12
A13	YA	YE	B13
A14	YB	YF	B14
A15	Y8	YC	B15
A16	Y9	YD	B16
A17	YA	YE	B17
A18	YB	YF	B18
A19	+	+	B19
A20	-	-	B20

(Note 1) When the polarities are mixed, a warning occurs and the ERR LED on the unit flashes to remind users to check the wiring. To make warnings not to be announced, set "Warning announcement" to "Not announce" in the "Multi I/O Unit Setting" screen of FPWIN GR7 (Ver.1.1 or later), or set the bit 9 of UM00062 to 1.

5.2.3 Application to Differential Output

It is possible to allocate one memory output for operation to two output circuits and obtain the differential output by applying the contact allocation functions of output terminal polarities and output terminals.

- Allocate the same I/O number to the terminals for two sets of four circuits by using ""Allocate contacts of output terminals"" in the "Multi I/O Settings" dialog box.
- Allocate "Sink" or "P-type push-pull (positive logic)", "Source" or "N-type push-pull (negative logic)" to ""Output terminal polarity"".
- Paired two terminals with the same I/O number are used as a pair of differential output.

In the following example, "Sink" and "Source" are allocated to the ""B11-B14"" and ""B15-B18"" terminals respectively, and used as differential outputs.

■ Terminal layout diagram

A1	X0	X8	B1
A2	X1	X9	B2
A3	X2	XA	B3
A4	X3	XB	B4
A5	X4	XC	B5
A6	X5	XD	B6
A7	X6	XE	B7
A8	X7	XF	B8
A9	COM	COM	B9
A10	COM	COM	B10
A11	Y0	Y8	B11
A12	Y1	Y9	B12
A13	X2	YA	B13
A14	Y3	YB	B14
A15	Y4	Y8	B15
A16	Y5	Y9	B16
A17	Y6	YA	B17
A18	Y7	YB	B18
A19	+	+	B19
A20	-	-	B20

Sink

Source

■ External connection diagram

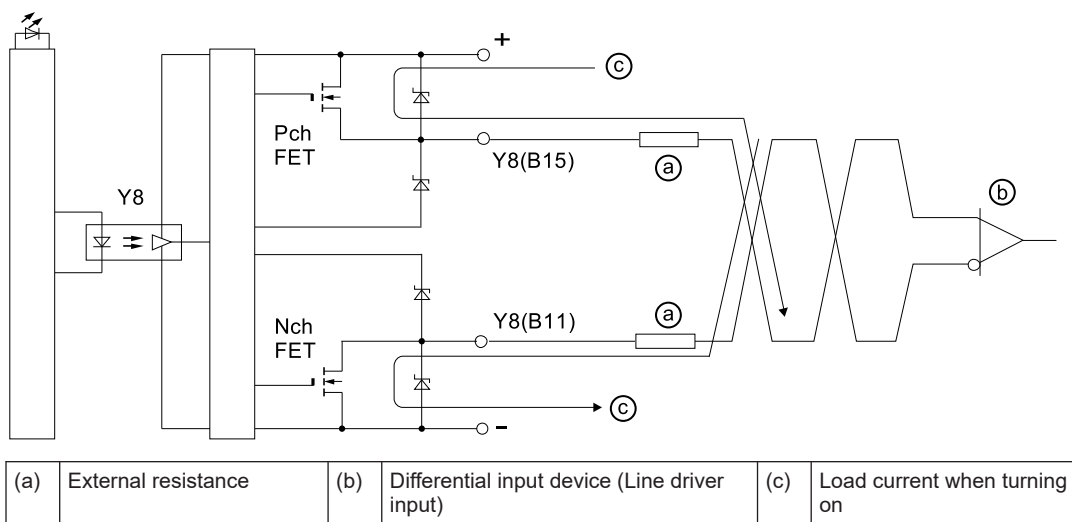

■ Configuration using FPWIN GR7

1 2 Procedure

1. Select **Options>Multi I/O Unit Setting** in the menu bar.
2. Select a unit.
The basic setup screen of "Multi I/O Unit Setting" will be displayed.
3. Set ""Output terminal polarity"".
Set the terminal number B11-B14 to Sink, and B15-B18 to Source.

5.2 Output Terminal Setting

Output terminal polarity

A11 - A14 : Sink output B11 - B14 : Sink output

A15 - A18 : Sink output B15 - B18 : Source output

Allocate contacts of output terminals

A11 - A14 : Y100 - Y103 B11 - B14 : Y100 - Y103

A15 - A18 : Y104 - Y107 B15 - B18 : Y10C - Y10F

4. Check the box for "Allocate contacts of output terminals" and set terminal numbers allocated to each contact.

Set the both terminals B11-B14 and B15-B18 to Y108-Y10B.

Output terminal polarity

A11 - A14 : Sink output B11 - B14 : Sink output

A15 - A18 : Sink output B15 - B18 : Source output

Allocate contacts of output terminals

A11 - A14 : Y100 - Y103 B11 - B14 : Y108 - Y10B

A15 - A18 : Y104 - Y107 B15 - B18 : Y10C - Y10F

(B11-14 is Sink and B15-18 is Source.)

i Info.

The terminal layout displayed on the left side of the Multi I/O Unit Setting dialog box is updated according to this setting.

Both terminals B11-B14 and B15-B18 are set to Y108-Y10B.

The terminals B11-B14 are minus outputs as they are set to Sink, and the terminals B15-B18 are plus outputs as they are set to Source.

Terminal layout

A1 - X100	B1 - X108
A2 - X101	B2 - X109
A3 - X102	B3 - X10A
A4 - X103	B4 - X10B
A5 - X104	B5 - X10C
A6 - X105	B6 - X10D
A7 - X106	B7 - X10E
A8 - X107	B8 - X10F
COM0	COM2
COM1	COM3
A11 - Y100	B11 - Y108
A12 - Y101	B12 - Y109
A13 - Y102	B13 - Y10A
A14 - Y103	B14 - Y10B
A15 - Y104	B15 - Y10C
A16 - Y105	B16 - Y10D
A17 - Y106	B17 - Y10E
A18 - Y107	B18 - Y10F
+	+
-	-

5.3 Application Setting

5.3.1 Overview

Set applications according to functions to be used as necessary. The following figure shows the case that high-speed counters are allocated to the inputs (X100 to X103) of the multi I/O unit of the starting word number 10.

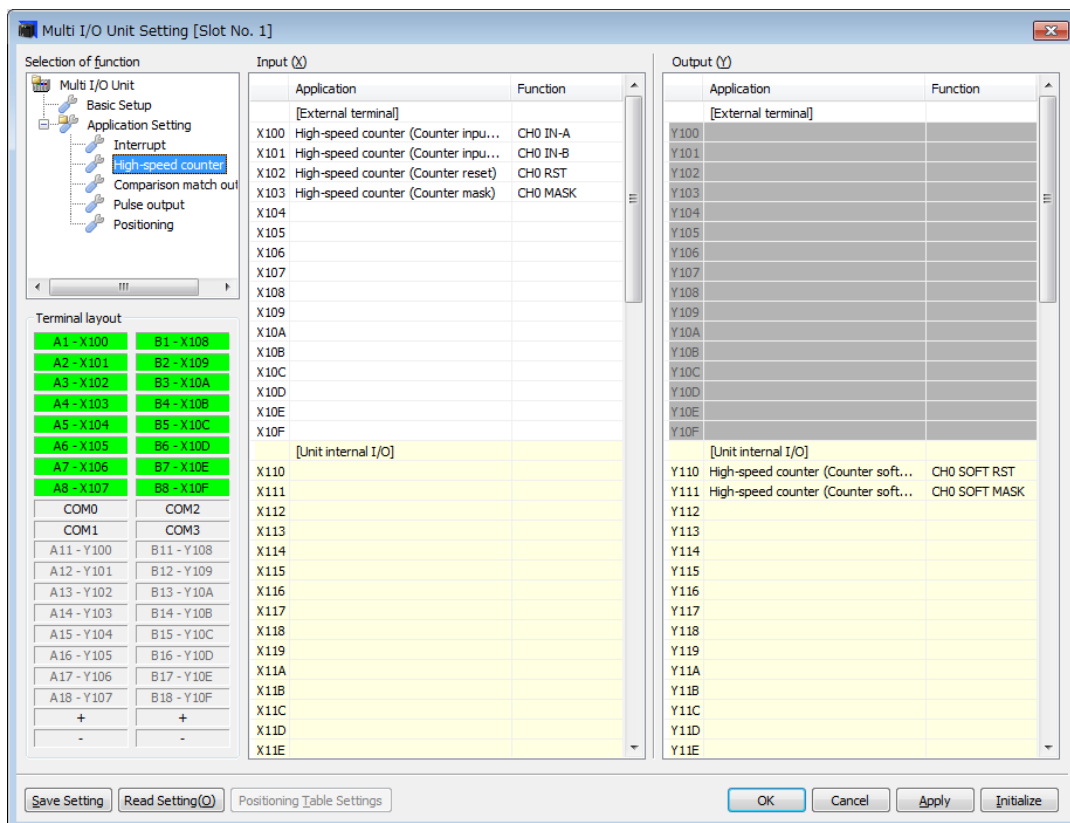

5.3.2 Setting Items by Use

■ Interrupt (INT0-INT7: Selectable by one point.)

Setting item	Settings
Function setting	Unused / Comparison match output (when comparison values match) / Comparison match output (OFF->ON) / (ON->OFF) / Comparison match output (OFF->ON) / Comparison match output (ON->OFF) / Interrupt terminal input (OFF->ON) / Interrupt terminal input (ON->OFF)

5.3 Application Setting

■ High-speed counter (HSC0-HSC3 / PLSC0-PLSC3: Selectable by channel.)

Setting item	Settings
Function setting	Unused/Direction distinction/Individual input/Phase input (multiplied by 1)/Phase input (multiplied by 2)/Phase input (multiplied by 4)
Elapsed value hold mode	Switch on the checkbox for using this mode.
Count mode	Ring / Linear
Counter elapsed value	-2147483648 to +2147483647
Counter preset value	-2147483648 to +2147483647
Counter upper/lower limit values	-2147483648 to +2147483647

■ Comparison match output (CMP0-CMP7: Selectable by one comparison output.)

Setting item	Settings
Compare	Switch on the checkbox for comparing.
Counter to be compared	High-speed Counter CH0/CH1/CH2/CH3 Pulse Output PLS0/PLS1/PLS2/PLS3 Positioning (H type only) CH0/CH1/CH2/CH3
Comparison Output Function	ON when elapsed value is smaller than setting value / ON when elapsed value is larger than or equal to setting value
Comparison value	-2147483648 to +2147483647
Comparison output destination	External terminal/Internal I/O Internal I/O

(Note 1) To set comparison match output, one of the following must be set: high-speed counter, pulse output, or positioning (H type only).

Info.

- For details of the interrupt function, refer to page "P.6-2".
- For details of the high-speed counter function, refer to page "P.7-2".
- For details of the comparison match output function, refer to page "P.8-2".

■ Pulse output / PWM output (PLS0-PLS3 / PWM0-PWM3: Selectable by channel.)

Setting item	Settings
Function setting	Unused/PLS output - Direction distinction/PLS output - Individual output/PLS output - Phase output/PLS output - Comparison match stop/PWM output
Data update timing	When start signal rises When start signal rises or upon comparison match output When start signal rises or when data is updated
Frequency	For pulse output: 0 to 500,000 (Can be set in 1 Hz increments) For PWM output: 0 to 100,000 (Can be set in 1 Hz increments)
Duty	0.0 to 100.0 (0.0% to 100.0%) (Only when using PWM output)
Counter elapsed value	-2147483648 to +2147483647

Setting item	Settings
Counter upper/lower limit values	-2147483648 to +2147483647
Pulse start logic (Except PWM output)	OFF start / ON start

■ Positioning (CH0-CH3: Selectable by channel)

Setting item	Settings
Function setting	Unused/Use/Use (Use J point terminal) ^(Note 1)
Counter elapsed value	-2147483648 to +2147483647
Counter upper/lower limit values	-2147483648 to +2147483647

(Note 1) Use (Use J point terminal) is only for CH0 - CH1.

Info.

- For details of the pulse output/PWM output function, refer to page "P.9-2".
- For details of the positioning function, refer to page "P.10-3".

(MEMO)

6 Interrupt Function

6.1 Interrupt Function.....	6-2
6.1.1 Overview of Interrupt Function.....	6-2
6.1.2 Setting of Unit Body.....	6-2
6.1.3 Configuration Using Tool Software.....	6-2
6.1.4 Overview of Interrupt Program.....	6-4
6.1.5 Precautions for Use.....	6-5
6.2 Execution Example of Interrupt Function.....	6-6
6.2.1 External Interrupt Input.....	6-6
6.2.2 Comparison Match Interrupt.....	6-7

6.1 Interrupt Function

6.1 Interrupt Function

6.1.1 Overview of Interrupt Function

- The multi input/output unit can start an interrupt program of the CPU unit using an interrupt input signal or counter comparison match flag.
- If the activation condition is met, the interrupt program of a corresponding program number will be activated. Once the execution of the interrupt program is complete, the process returns to the execution of the main program.

■ Interrupt function specifications

Item	Specifications	
No. of interrupt programs ^{(Note 1)(Note 2)}	Per multi I/O unit	Max. 8 programs
	Per CPU unit	Max. 64 programs (8 programs x 8 units)
Interrupt condition	Any of the following conditions can be selected by one point. External input (X8-XF) rising edge(OFF > ON) External input (X8-XF) falling edge(ON > OFF) Comparison match ^(Note 3)	

(Note 1) If interrupts occur many times in one scan, the execution of interrupt program has priority, and the scan time will be longer.

(Note 2) If more than one interrupt activation request is made from the unit, the process will be carried out from the smallest slot number or the smallest interrupt program number.

(Note 3) The interrupt program will start when the counter elapsed value agrees with the comparison value when using the comparison function. On the unit Ver.1.1 or later, the following conditions can be set as interrupt conditions: Comparison match output (OFF > ON/ON > OFF), comparison match output (OFF > ON), comparison match output (ON > OFF)

6.1.2 Setting of Unit Body

■ Setting method

For using the interrupt function, it is necessary to set the switch on the side of the unit. Refer to "2.1 Names and functions of parts".

6.1.3 Configuration Using Tool Software

The settings of the interrupt function are specified in the configuration menu of FPWIN GR7.

■ Setting method

The following procedure shows allocating ""External interrupt input (OFF -> ON)"" to the input (X108) of the multi I/O unit registered with the starting word number 10. It also describes the procedure when the multi I/O unit has been already allocated in the I/O map.

1 2 Procedure

1. Select **Options>Multi I/O Unit Setting** in the menu bar.
The "Multi I/O Unit Setting" dialog box is displayed. Select a unit to be used.
2. From the function select tree, select "Interrupt", and double-click an interrupt number to which the interrupt input is allocated.
The "Interrupt Advanced" dialog box is displayed.
3. Select an arbitrary interrupt condition.
A used terminal number will be automatically allocated.

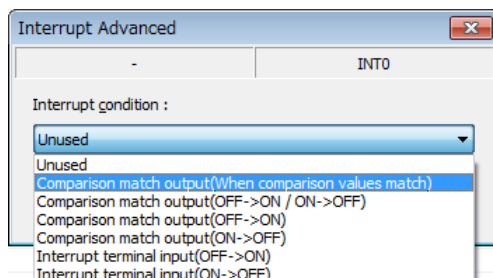

4. Press the [[OK]] button.
The selected condition will be registered in the interrupt execution condition. The following figure shows an example of allocating "Interrupt terminal input (OFF > ON)" to the interrupt number INT0 of the Multi I/O Unit.

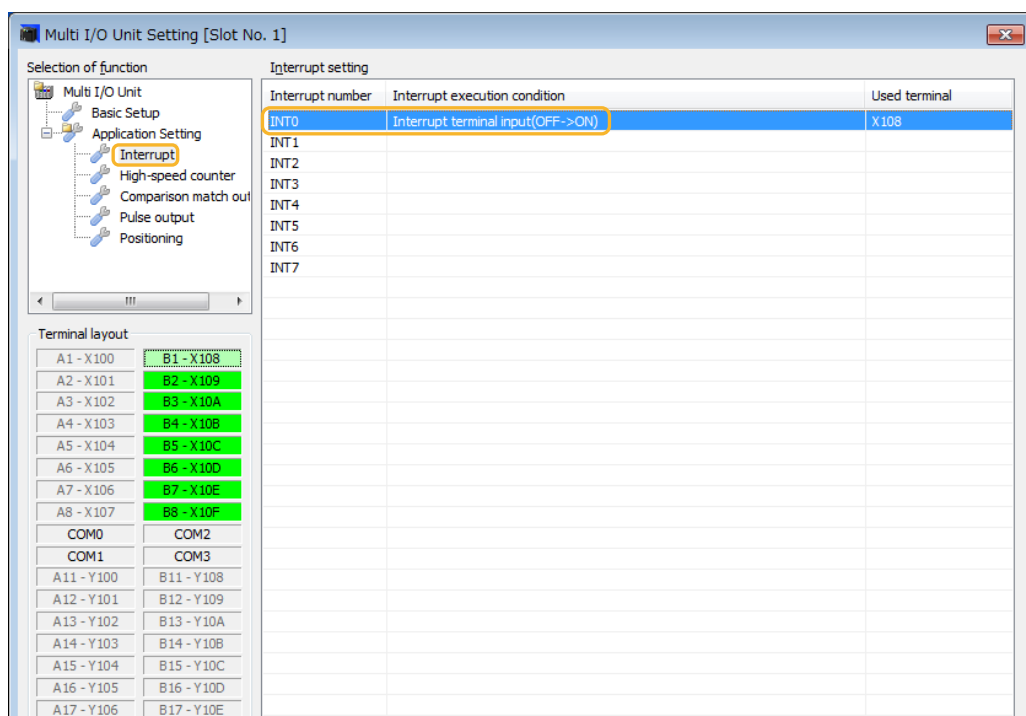

The set values will be effective when they are downloaded with programs or other configuration information as a project.

6.1 Interrupt Function

6.1.4 Overview of Interrupt Program

Use the following instructions to execute the activation of an interrupt program.

■ Instructions used for interrupt program activation

Described area	Instruction	Functions
Main program	EI	Allows the interrupt process for the CPU.
	DI	Prohibits the interrupt process for the CPU.
	IMASK	Allows or prohibits the interrupt process of each unit.
	ICLR	Clears the interrupt start request signal that has not been processed on the unit side when interrupt program activation is prohibited by DI or IMASK instructions.
Interrupt program	INTPG	It is described at the beginning of the interrupt program.
	IRET	It is described at the end of the interrupt program.

■ Programming method (Main program)

The interrupt for the CPU and the interrupt activation of the multi I/O unit are allowed in the main program. If the interrupt becomes disabled, clear the interrupt activation request signal that is not processed in the unit as necessary.

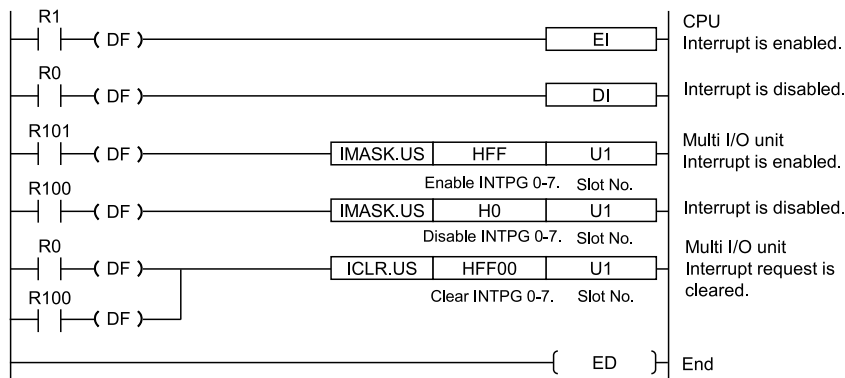

■ Programming method (Interrupt program)

- Describe the program to be executed at the time of interrupt process in the interrupt program.

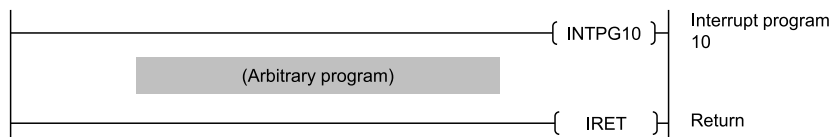

■ Corresponding interrupt program numbers

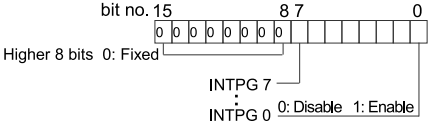
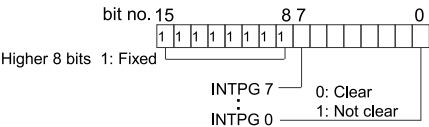
Interrupt program No.	Multi I/O unit interrupt No.	Designation of the first operand of IMASK and ICLR instructions
INTPG 10	INT0 (Input X8 or EQ0)	IMASK instruction 
INTPG 11	INT1 (Input X9 or EQ1)	
INTPG 12	INT2 (Input XA or EQ2)	
INTPG 13	INT3 (Input XB or EQ3)	
INTPG 14	INT4 (Input XC or EQ4)	
INTPG 15	INT5 (Input XD or EQ5)	
INTPG 16	INT6 (Input XE or EQ6)	
INTPG 17	INT7 (Input XF or EQ7)	ICLR instruction 

(Note 1) Interrupt program numbers are specified with slot numbers + (0 to 7). The numbers in the above table are for the slot 1.

Example) The program number corresponding to the interrupt INT3 of the multi I/O unit of the slot number 10 is INTPG03.

i Info.

- Either interrupt (X8-XF) by an external input or comparison match signal (EQ0-EQ7) when using the comparison output function is allocated to the interrupt number of the multi I/O unit by the tool software or the setting with a program. For details of the comparison match signals (EQ0-EQ7), refer to ""8.1.2 Comparison Output and Comparison Match Signal"".

6.1.5 Precautions for Use

■ Process when more than one interrupt activation request is made

- If more than one interrupt activation request is made from the unit, the process will be carried out from the smallest slot number or the smallest interrupt program number.
- If the interrupt activation is requested on the completion of the process of interrupt program, a higher-priority program will be searched and the corresponding interrupt program will be executed.
- Interrupt activation request signals on the unit side will be held until the corresponding interrupt program is executed or ICLR instruction is executed.

Note

- If interrupts occur many times in one scan, the execution of interrupt program has priority, and the scan time will be longer.

6.2 Execution Example of Interrupt Function

6.2 Execution Example of Interrupt Function

6.2.1 External Interrupt Input

■ Overview

- The following figure shows the example that the output (Y160) from the 32-point output unit is output at a high speed by the processing of an interrupt program when inputting the external input (INT0) of the multi I/O unit (X108) in the state that the interlock input (X140) is input to the 32-point input unit.
- In the normal processing that does not use the interrupt processing, it is reflected by the scan time from an input to the signal output. However, when performing the interrupt processing, the input status is reflected to the output with a slight delay that is not influenced by the scan time.

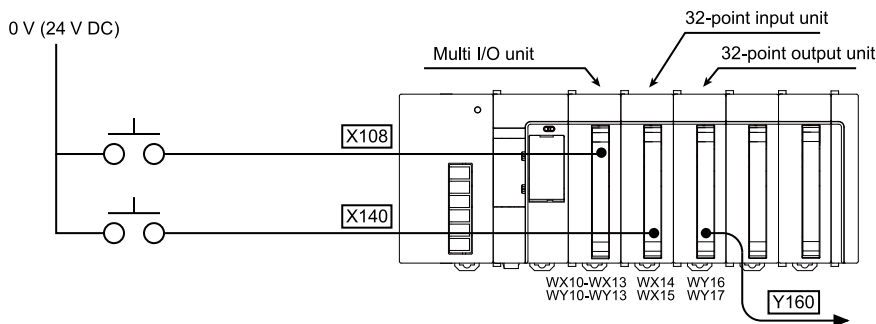

■ Configuration

- Allocate an interrupt input to the input (X108) in the "Multi I/O Unit Setting" dialog box.
- Allocate "Interrupt terminal input (OFF -> ON)" as an interrupt occurrence condition.

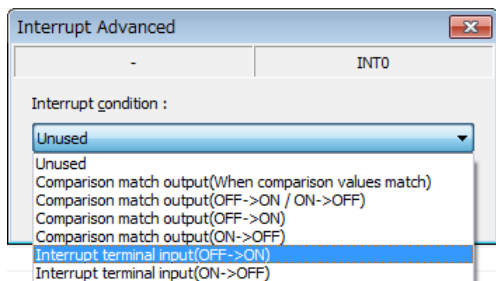

■ Time chart

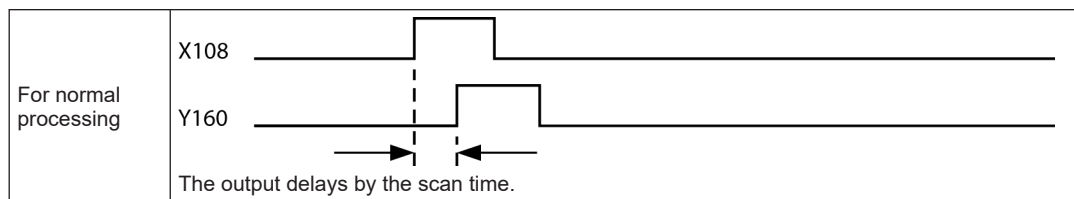

6.2 Execution Example of Interrupt Function

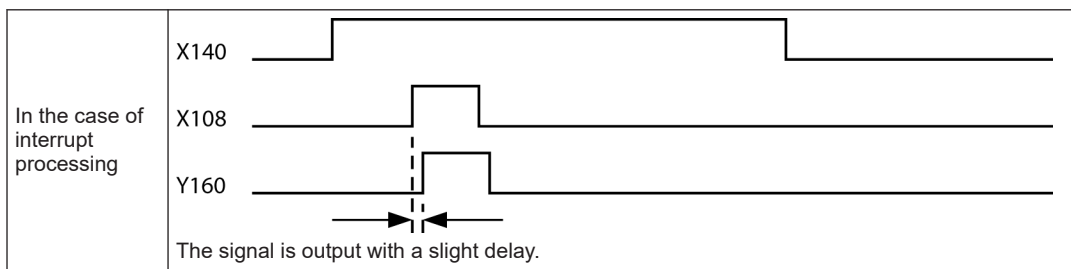

■ Program example

- Describe the interrupt enable instruction before the ED instruction, and describe a program to be executed by the interrupt processing after the ED instruction.
- The interrupt program number corresponding to the input (X108) is INTPG10.

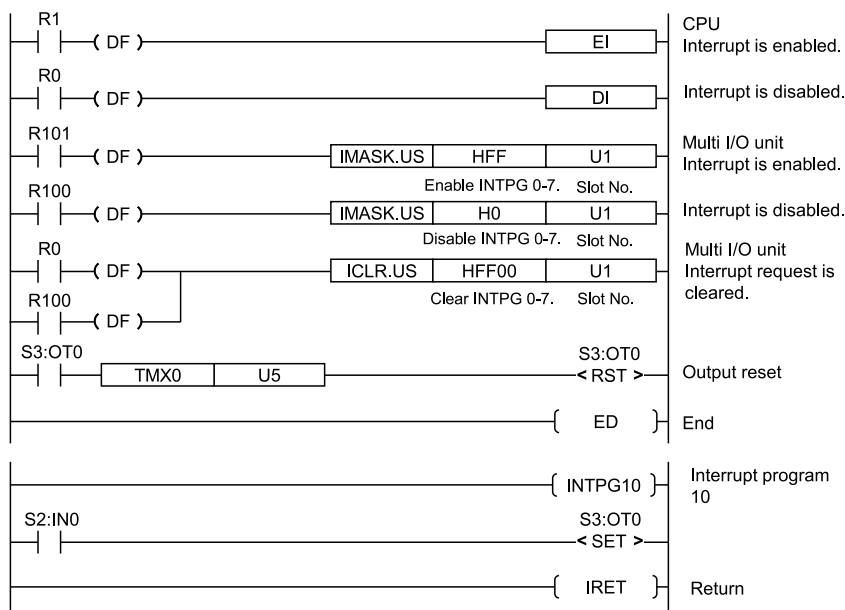

(Note 1) The input (X140) corresponds to (S2: IN0) in the program, and the output (X160) corresponds to (S3: OT0).

(Note 2) For the unit which uses direct input (IN) and direct output (OT), set ""Exclude this unit from I/O refresh"" in the I/O map.

6.2.2 Comparison Match Interrupt

■ Overview

- The high-speed counters are allocated to the inputs (X100-X103) of the multi I/O unit.
- (For the interrupt occurred when comparison values match)**
- The interrupt (INT0) occurs when the counted pulse number matches the ""Comparison output setting value"" that has been specified. The interrupt program from INT0 of a

6.2 Execution Example of Interrupt Function

sequence program until IRET is executed, and the output (Y160) of the 32-point output unit is output at a high speed.

(For the interrupt occurred at the same time as comparison output)

- The interrupt (INT0) occurs at the same time as the comparison output. The interrupt program from INT0 of a sequence program until IRET is executed, and the output (Y160) of the 32-point output unit is output at a high speed.

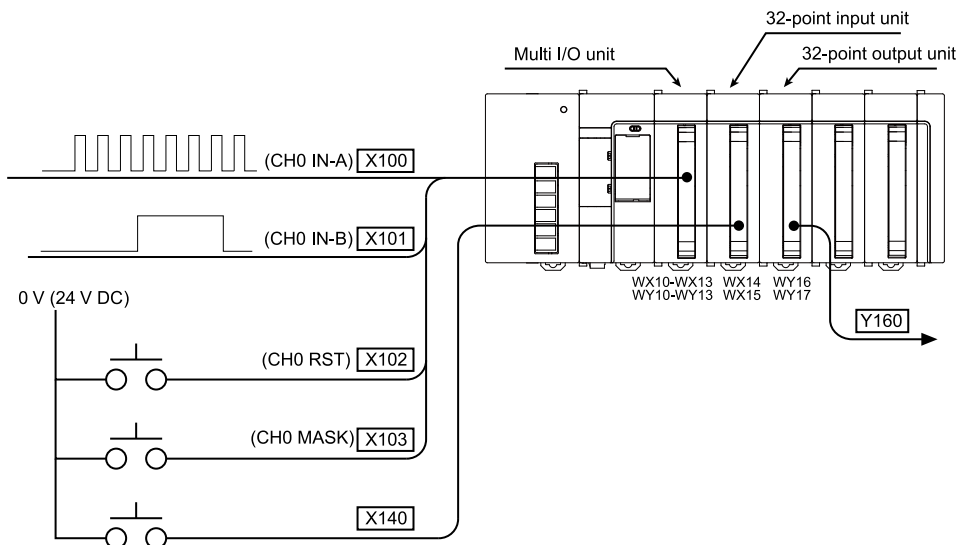

■ Configuration

- From the function selection tree, select ""High-speed counter"", allocate high-speed counter inputs to the inputs (X100-X103), and select ""Direction distinction"".
- From the function selection tree, select ""Comparison match output"", and select ""High-speed counter CH0"" as a counter to compare the comparison match number CMP0 (external terminal number: Y100).

(For the interrupt occurred when comparison values match)

- From the function selection tree, select ""Interrupt"", and select ""Comparison match output (When comparison values match)"" from the interrupt conditions in the Interrupt Advanced settings.

(For the interrupt occurred at the same time as comparison output)

- From the function selection tree, select ""Interrupt"", and select ""Comparison match output (OFF->ON/ON->OFF)"" from the interrupt conditions.

6.2 Execution Example of Interrupt Function

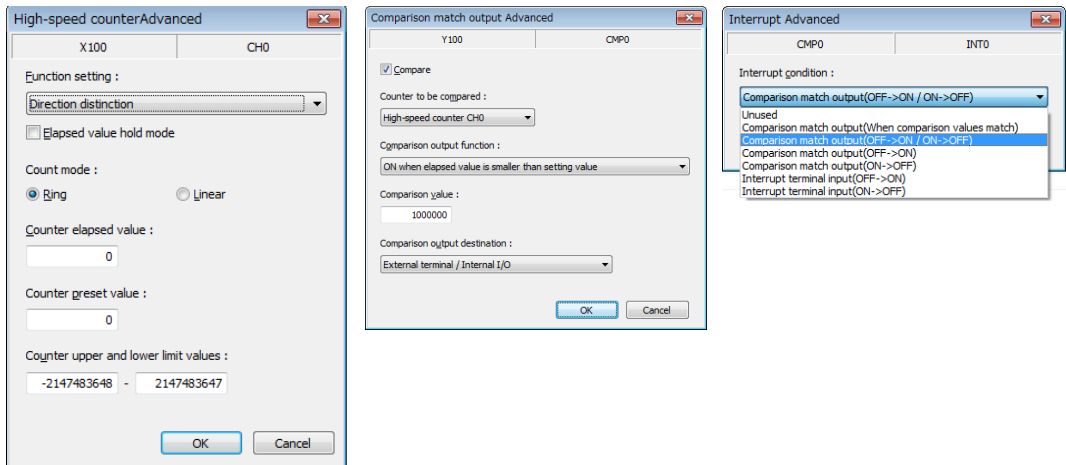

6.2 Execution Example of Interrupt Function

■ Time chart (For the interrupt occurred when comparison values match)

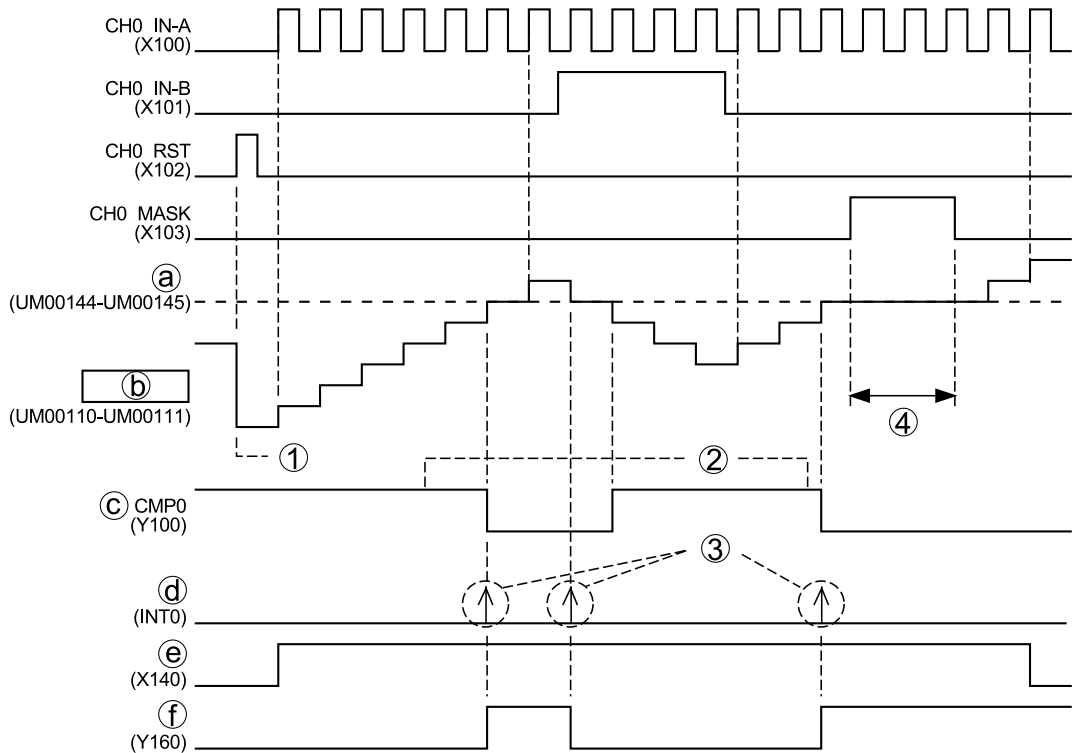

(a)	Comparison output setting value	(1)	The count value is reset when the reset signal turns on.
(b)	Counter elapsed value	(2)	The comparison output turns on when the elapsed value is smaller than the setting value.
(c)	Comparison	(3)	An interrupt occurs when the elapsed value agrees with the comparison output setting value by the interrupt occurrence condition.
(d)	Comparison match Interrupt	(4)	Counting is disabled while the mask signal is on.
(e)	32-point input unit Interlock input		
(f)	32-Point output unit External output		

■ Time chart (For the interrupt occurred when comparison values match)

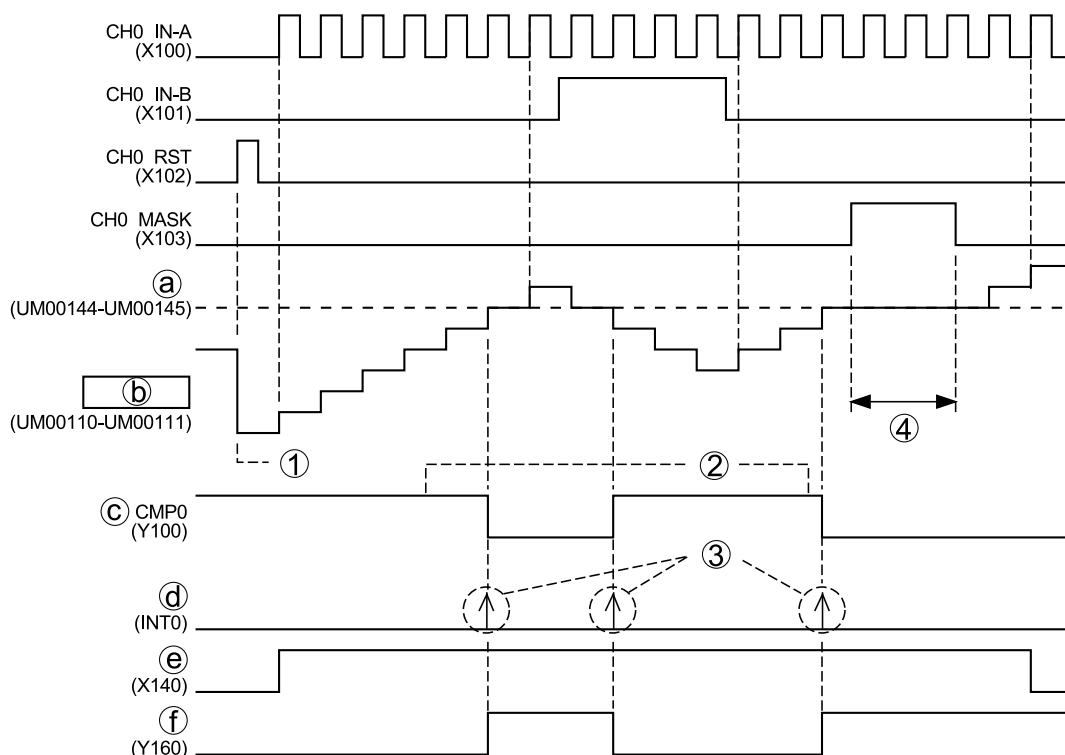

(a)	Comparison output setting value	(1)	The count value is reset when the reset signal turns on.
(b)	Counter elapsed value	(2)	The comparison output turns on when the elapsed value is smaller than the setting value.
(c)	Comparison	(3)	An interrupt occurs when the comparison output turns on or off by the interrupt occurrence condition.
(d)	Comparison match Interrupt	(4)	Counting is disabled while the mask signal is on.
(e)	32-point input unit Interlock input		
(f)	32-Point output unit External output		

■ Program example

- Describe the interrupt enable instruction before the ED instruction, and describe a program to be executed by the interrupt processing after the ED instruction.
- The interrupt program number corresponding to the match output CMP0 (EQ0) is INTPG10.

6.2 Execution Example of Interrupt Function

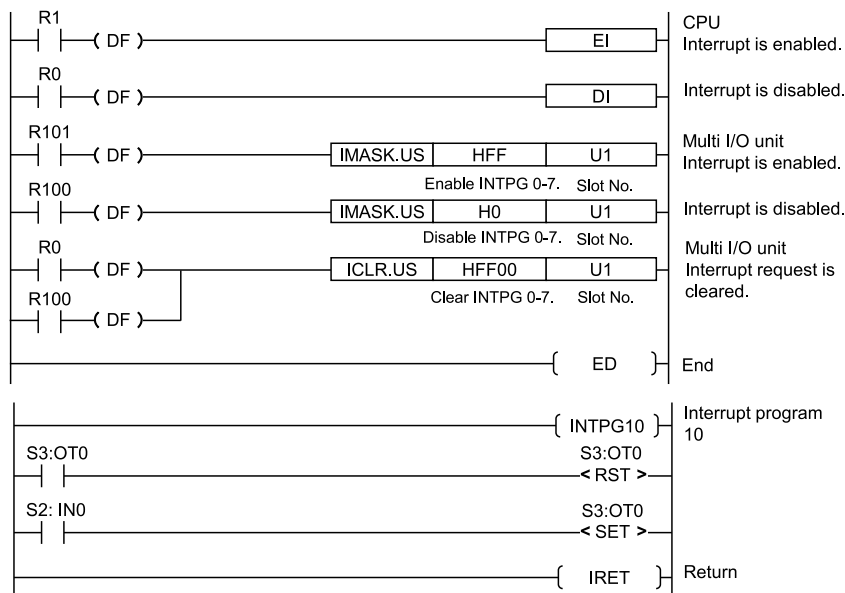

(Note 1) The input (X140) corresponds to (S2: IN0) in the program, and the output (X160) corresponds to (S3: OT0).

(Note 2) For the unit which uses direct input (IN) and direct output (OT), set ""Exclude this unit from I/O refresh"" in the I/O map.

i Info.

- For more information about how to use the counter function, refer to ""7 Counter Function"".
- For more information about how to use the comparison output function, refer to ""8 Comparison Output Function"".

7 Counter Function

7.1 Counter Function	7-2
7.1.1 Overview of Counter Function	7-2
7.1.2 Configuration Using Tool Software.....	7-3
7.1.3 Linear Counter and Ring Counter	7-4
7.1.4 Selection of Count Methods.....	7-6
7.2 Control Signals.....	7-9
7.2.1 Reset and Mask	7-9
7.3 Read/Write of Elapsed Value	7-10
7.3.1 Elapsed Value When Power Turns On.....	7-10
7.3.2 Reading Elapsed Value.....	7-10
7.3.3 Changing Elapsed Value.....	7-10
7.3.4 Resetting/Presetting Elapsed Value.....	7-10
7.4 Elapsed Value Hold Function.....	7-12
7.4.1 Overview	7-12
7.4.2 Operation	7-13
7.5 Input Frequency Measurement Function	7-14
7.5.1 Overview	7-14
7.5.2 Reading Measurement Value.....	7-14

7.1 Counter Function

7.1 Counter Function

7.1.1 Overview of Counter Function

- The count function is used to count the number of input pulses and reflect it to the elapsed value. The frequencies of input pulses can also be measured.
- When an external output is necessary, use this function in combination with the comparison function.
- There is also a function which holds the elapsed value at the time of the trigger input signal from an external device. For details, refer to ["7.4 Elapsed Value Hold Function"](#).

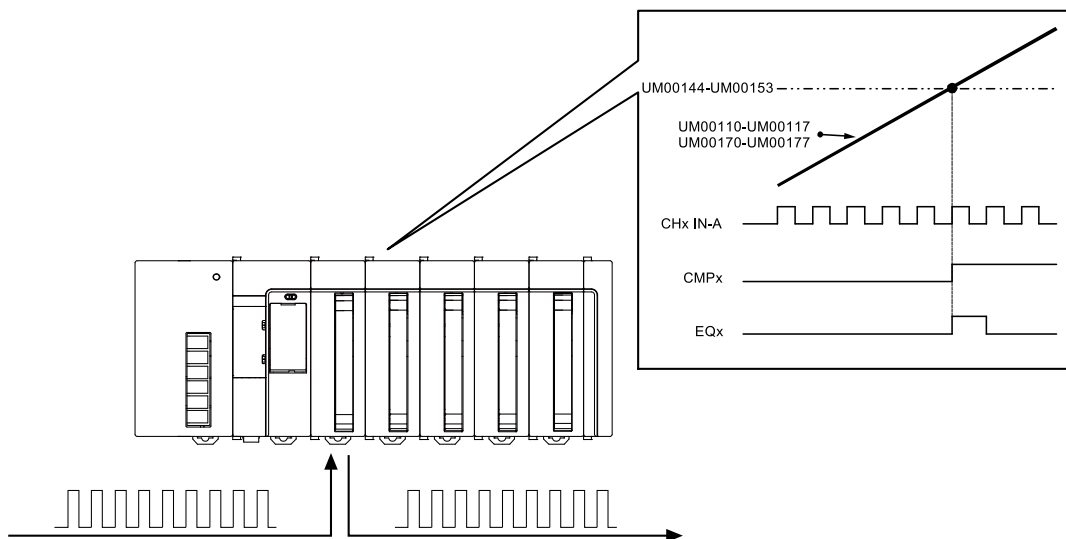

■ Outline of specifications

Item	Specifications
Counter type	Linear counter/Ring counter
Number of channels	Max. 4 channels
Counting range	-2147483648 to +2147483647
Max. counting speed ^{(Note 1)(Note 2)}	When input voltage is 5 V: 500 Hz (For phase input: 500 kHz) When input voltage is 12V: 500 kHz (For phase input: 350kHz) When input voltage is 24V: 250 kHz (For phase input: 180kHz)
Count method	Direction distinction input, Individual input, Phase input (1 multiple, 2 multiple, 4 multiple)
Optional functions	Comparison output setting: Max. 8 points Elapsed Value Offset/Preset Function Elapsed Value Hold Function Count upper and lower limit settings Overflow/underflow detection (Linear counter only) Input pulse frequency measurement

(Note 1) By default, the input time constant is set to 2 μ s. Change the setting according to the frequencies required. (The count upper limit at 2 μ s is approx. 100 kHz.)

(Note 2) This applies when the input pulse duty is 50%.

i Info.

- Besides the purpose which counts input pulses from external devices, pulses generated by them can be counted internally when using the pulse output/PWM output function. For details of the counter for the pulse output/PWM output, also refer to ["9 Pulse Output/PWM Output Function"](#).

7.1.2 Configuration Using Tool Software

The setting of the counter function is specified in the configuration menu of FPWIN GR7.

■ Setting method

The following procedure shows when ["High-speed counter \(Phase input\)"](#) is allocated to the inputs (X100-X103) of the multi I/O unit registered in the starting word number 10. It also describes the procedure when the multi I/O unit has been already allocated in the I/O map.

1 2 Procedure

1. Select **Options>Multi I/O Unit Setting** in the menu bar.
The ["Multi I/O Unit Setting"](#) dialog box is displayed. Select a unit to be used.
2. From the function selection tree, select ["High-speed counter"](#), and double-click an input number to which the high-speed counter is allocated.
The ["High-speed Counter Advanced"](#) dialog box is displayed.
3. Select ["Phase input \(4 multiple\)"](#) from the ["Function Setting"](#) drop-down list.
4. Input a preset value or upper and lower limit values as necessary.

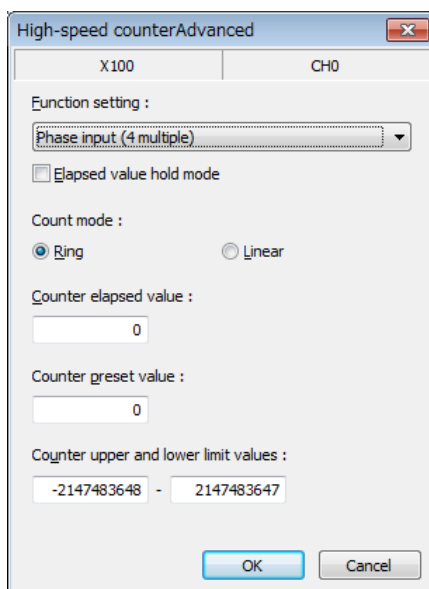

7.1 Counter Function

5. Press the [[OK]] button.

The selected condition will be registered in the ""Multi I/O Unit Setting"" dialog box.

The following figure shows an example when ""High-speed counter (Phase input)"" is allocated to the inputs (X100-X103) of the multi I/O unit. The output for control is automatically allocated to the outputs (Y110-Y111) of the unit's internal I/O.

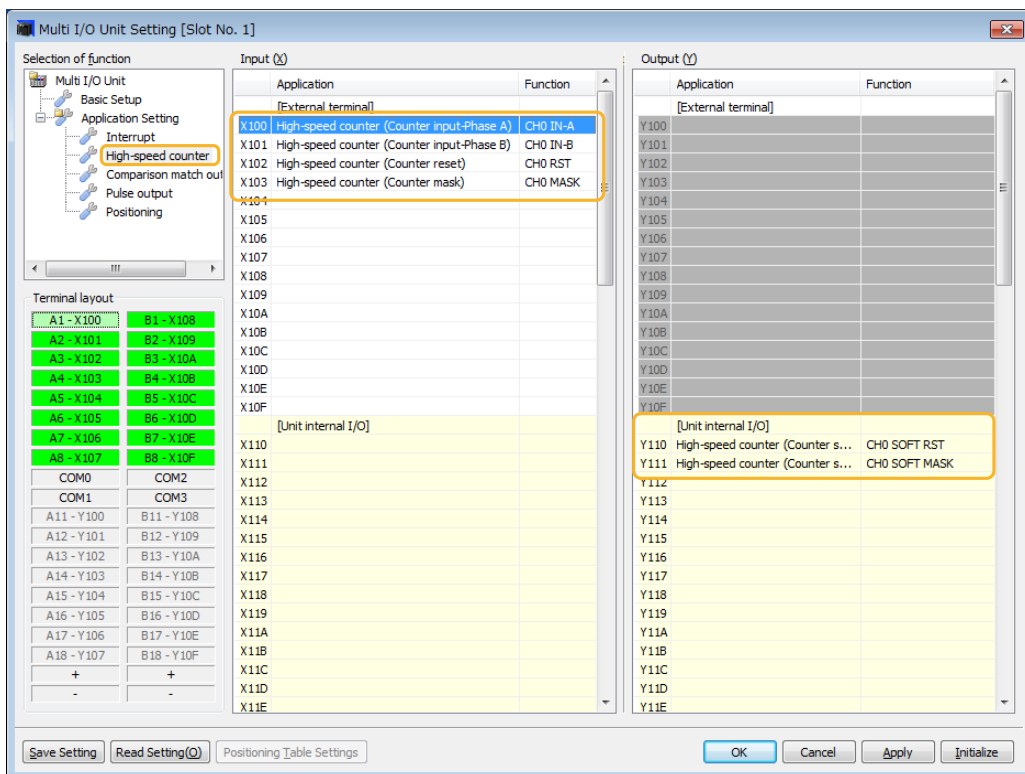

The set values will be effective when they are downloaded with programs or other configuration information as a project.

Settings of counter elapsed value and counter preset value

The values set in the ""Counter Advanced"" dialog box are applied as follows.

Item	Operation	Related unit memory
Counter elapsed value	The value set for ""Counter elapsed value"" in the dialog box is set in the elapsed value area after switching the mode to RUN mode.	UM00110-UM00117
Counter preset value	The value set for ""Counter preset value"" in the dialog box is set in the elapsed value area when the reset operation is performed with a control signal.	UM00118-UM0011F

7.1.3 Linear Counter and Ring Counter

The operation changes depending on the types of counter as below.

Operational difference between the counter types

Comparison item	Linear counter	Ring counter
Operation image		
Operation when reaching the upper limit or lower limit	<p>If the count value exceeds the upper limit, the upper limit will be held.</p> <p>If the count value falls below the lower limit, the lower limit will be held. (Note 1)</p>	<p>If the count value exceeds the upper limit, the count value will be the lower limit automatically and the count operation will continue.</p> <p>If the count value falls below the lower limit, the count value will automatically become the upper limit and the count operation will continue. (Note 1)</p>
Overflow Underflow	<p>When an overflow or underflow occurs, it will be reflected to the input relays X20-X27) as a flag. The count operation will be restart until the overflow or underflow is cleared, and the elapsed value will be held.</p>	<p>Even when the value exceeds the upper limit or lower limit, it will not be considered as an overflow or underflow, and the count will continue.</p>

(Note 1) When the upper limit or the lower limit has been changed in the configuration menu, the counter operates based on its range.

Operation in case of overflow or underflow (Linear counter only)

- The overflow or underflow flags (X20-X27) can be cleared by the overflow clear or underflow clear request signals (Y20-Y27).

i Info.

- For the details of I/O signals related to overflow and underflow, refer to ""13.2 Allocation of I/O Numbers"".

Linear counter operation

The overflow or underflow is detected when the count value exceeds the upper or lower limit.

(Example): The following figure shows when underflow occurs. When the underflow occurs, the elapsed value will be held at the lower limit. Once the underflow clear signal turns on, the count will restart from the lower limit.

7.1 Counter Function

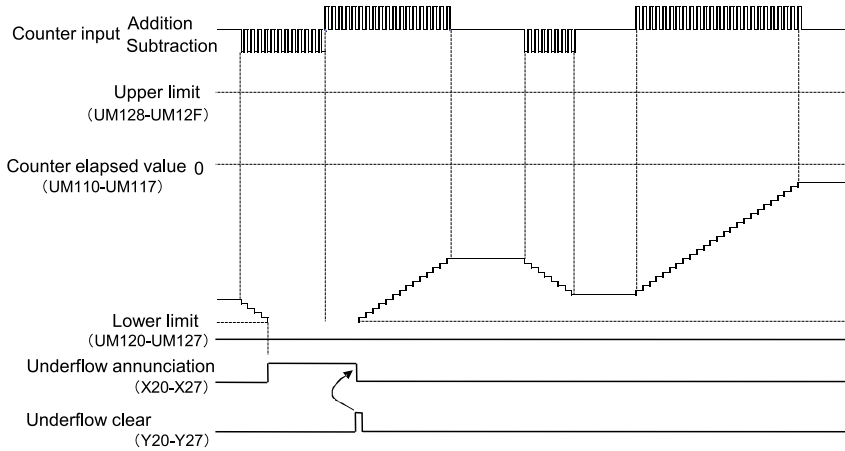

■ Ring counter operation

- If the lower limit is counted down, the count value will be rolled over, and counting down will continue from the upper limit.
- If the upper limit is counted up, the count value will be rolled over, and counting up will continue from the lower limit.

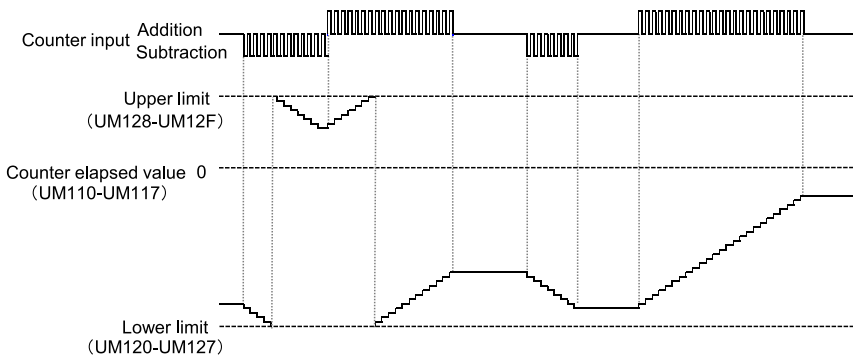

7.1.4 Selection of Count Methods

- Select from the following three types according to input devices to be connected.
- For phase input, the count operation varies depending on the settings of multiplication factor, as shown below.

■ Count method

Method	Connection	Count
Direction distinction		<p>For the direction distinction input, the count signal is connected to the input A signal. The count direction is controlled by the level of the direction signal of the input B signal.</p> <p>When the input B signal is off, the counter is incremented when the input A signal rises or falls. When the input B signal is on, the counter is decremented.</p>
Individual		<p>In the individual input method, the counter is incremented when the input A signal rises or falls, and decremented when the input B signal rises or falls.</p>
Phase		<p>For the phase input, the input A signal and input B signal of each counter are connected to the phase A and phase B of an encoder.</p> <p>The count direction is determined by the phase difference between phase A and phase B. When phase A is advanced by 90 degrees in electrical angle compared to phase B, the count value is incremented. When phase A is delayed by 90 degrees in electrical angle compared to phase B, the count value is decremented.</p>

■ Count operation of direction distinction input

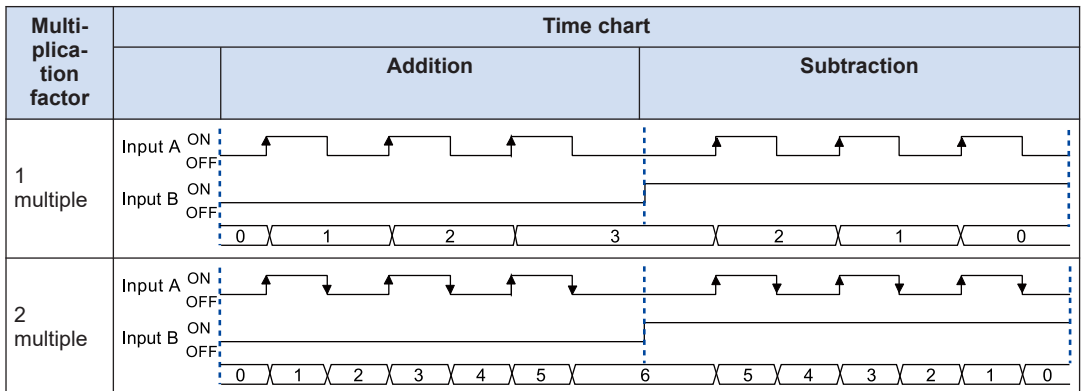

7.1 Counter Function

Count operation of individual input

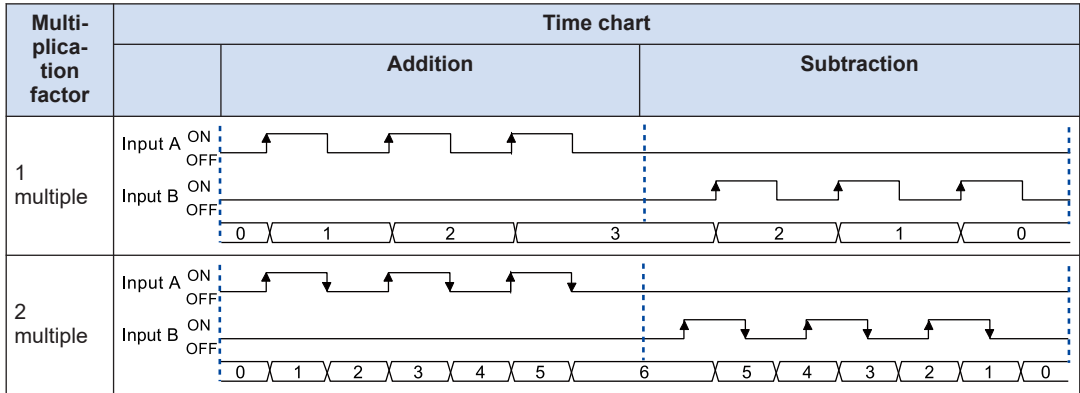

Count operation of phase input

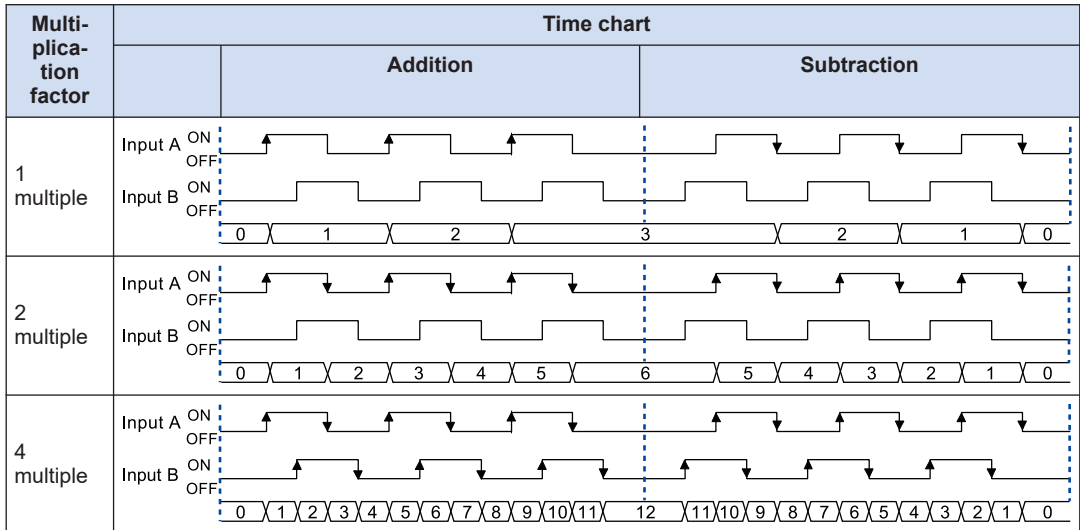



7.2 Control Signals

7.2.1 Reset and Mask



- The reset and mask operations can be performed with the counter for external inputs.
- The both operations can be performed by the inputs from external input terminals or user programs.
- Once executing the reset operation, values will return to the preset values stored in the unit memories (UM00118-UM0011F). The preset values can be set in the "High-speed Counter Advanced" dialog box of the tool software or using user programs.

■ I/O allocation (Control by external input terminals)

Signal name	Valid Condition	CH0	CH1	CH2	CH3
Reset CHxRST	Level 	X102	X106	X10A	X10E
Mask CHxMASK	Level 	X103	X107	X10B	X10F

(Note 1) The I/O numbers in the table above are for slot number 1 and the starting word number 10. The I/O numbers actually used vary according to the slot number where the unit is installed and the starting word number.

■ I/O allocation (Control by programs)

Signal name	Valid Condition	CH0	CH1	CH2	CH3
Reset CHxRST	Level 	Y110	Y112	Y114	Y116
Mask CHxMASK	Level 	Y111	Y113	Y115	Y117

(Note 1) The I/O numbers in the table above are for slot number 1 and the starting word number 10. The I/O numbers actually used vary according to the slot number where the unit is installed and the starting word number.

■ Unit memory (UM) allocation

Signal name	CH0	CH1	CH2	CH3
Counter preset value	UM00118-UM00119	UM0011A-UM0011B	UM0011C-UM0011D	UM0011E-UM0011F

7.3 Read/Write of Elapsed Value

7.3 Read/Write of Elapsed Value

7.3.1 Elapsed Value When Power Turns On

- The default for the elapsed value when the power turns on is ""0"".
- The count value when the power turns on can be set to any value as necessary. It can be set to an arbitrary value in the configuration menu of the tool software or user programs.

7.3.2 Reading Elapsed Value

The elapsed value can be read from the unit memory area.

Example) Program to read the elapsed value of the counter CH0 for external inputs

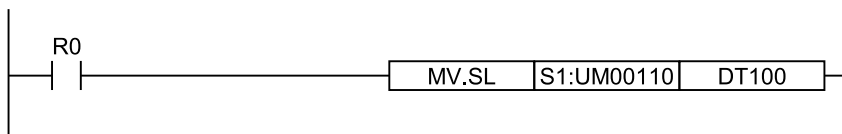

7.3.3 Changing Elapsed Value

The elapsed value can be set to an arbitrary value using a user program as necessary.

Example) Program to change the elapsed value of the counter CH0 for external inputs to 100000

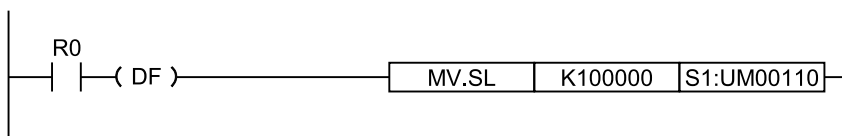

■ Unit memory (UM) allocation

Signal name	CH0	CH1	CH2	CH3
Counter elapsed value area	UM00110-UM00111	UM00112-UM00113	UM00114-UM00115	UM00116-UM00117

7.3.4 Resetting/Presetting Elapsed Value

The counter elapsed value can be preset by the output ChxRST.

Example) Program to change the elapsed value of the counter CH0 for external inputs to a preset value.

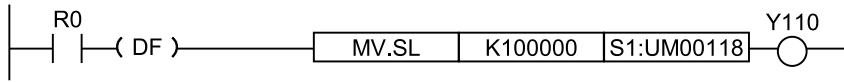

■ Unit memory (UM) allocation

Signal name	CH0	CH1	CH2	CH3
Counter preset value	UM00118-UM00119	UM0011A-UM0011B	UM0011C-UM0011D	UM0011E-UM0011F

7.4 Elapsed Value Hold Function

7.4 Elapsed Value Hold Function

7.4.1 Overview

- The elapsed value hold function is a function which holds the elapsed value of the counter at the time of the trigger input signal from an external device.
- The elapsed value hold function is available only for CH0 and CH1. Each elapsed value is transferred to the hold value areas allocated to each channel.
- It will be valid by turning on the signal (CHx LATCH EN) with a user program.
- The input logics (ON -> OFF edge, and OFF -> ON edge) which enable trigger input signals can be switched by the signal (CHx TRG LOG).

■ I/O allocation

Name	CH0	CH1	Description
CHx IN-A	X100	X104	They occupy the counter areas for external inputs (4 points for each channel).
CHx IN-B	X101	X105	
CHx RST	X102	X106	
CHx MASK	X103	X107	
CHx TRG	Y108	X10C	Trigger input signal by an external input.
CHx LATCH EN	Y114	Y116	Enables the elapsed value hold function.
CHx TRG LOG	Y115	Y117	Switches the valid condition of trigger input signals. When this is on, the ON -> OFF edge of the trigger signals (X8, XC) is valid. When this is off, the OFF -> ON edge of the trigger signals (X8, XC) is valid.

(Note 1) The I/O numbers in the table above are for slot number 1 and the starting word number 10. The I/O numbers actually used vary according to the slot number where the unit is installed and the starting word number.

■ Unit memory (UM) allocation

Name	CH0	CH1
Counter elapsed value area	UM00110-UM00111	UM00112-UM00113
Counter hold value area	UM00114-UM00115	UM00116-UM00117

■ Configuration

When allocating ""High-speed counter"" to the inputs (X100-X107) in the ""Multi I/O Unit Setting"" dialog box, check the box for ""Elapsed value hold mode"".

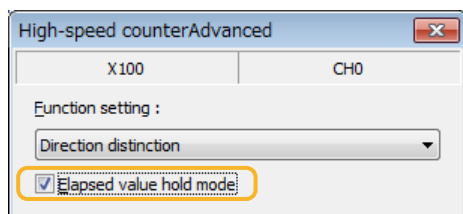

7.4.2 Operation

The following time chart shows when the "elapsed value hold function" is set for the high-speed counter CH0 and is enabled when the input logic of a trigger signal is (ON > OFF).

■ Time chart

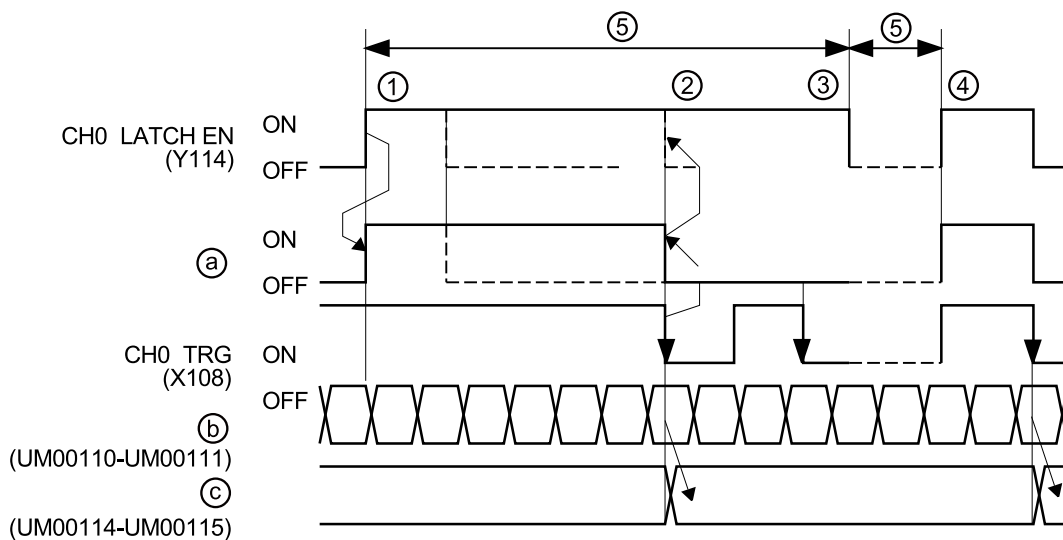

Mark	Procedure	Description
(a)	Enable trigger input	It shows the timing that the hold function becomes enabled within the unit.
(b)	Elapsed value area	Elapsed value area of the counter.
(c)	Hold value area	Area in which the hold values are stored.
(1)	Enable latch	The trigger input (X108) becomes enabled when the latch enable signal CHxLATCH EN (Y114) is turned on by the user program.
(2)	Trigger input	When the trigger signal (X108) from an external device turns off, the counter elapsed values (UM00110-UM00111) will be stored in the storage areas (UM00114-UM00115).
(3)	Wait	After accepting the trigger input and holding the counter elapsed values, the hold operation will not be performed until the latch enable signal (Y114) turns on. To hold the next data, change the state of the latch enable signal (Y114) as ON -> OFF -> ON with the user program.
(4)	Enable latch	When the LATCH EN signal (Y114) turns on after turning off the CHxLATCH EN signal on the user program, the trigger input will be enabled.
(5)	1 scan or more	Ensure a time more than one scan time by the operation with the user program.

7.5 Input Frequency Measurement Function

7.5 Input Frequency Measurement Function

7.5.1 Overview

- The measurement function is to measure the changes in the count values of the high-speed counter for external outputs and to output them as frequencies.
- Measuring results are stored in unit memories (UM). They can be read by user programs if necessary.
- As the measurement function is enabled automatically when the high-speed counter for external inputs is allocated, the configuration for using the input frequency measurement function is not required.

7.5.2 Reading Measurement Value

Measurement values can be read from the unit memory area.

Example) Program to read the input frequency measurement value of the counter CH0 for external inputs

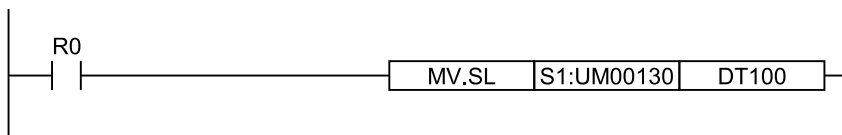

■ Unit memory (UM) allocation

Signal name	CH0	CH1	CH2	CH3
Counter input Frequency measurement value	UM00130-UM00131	UM00132-UM00133	UM00134-UM00135	UM00136-UM00137

8 Comparison Output Function

8.1 Comparison Output Function	8-2
8.1.1 Overview of Comparison Output Function	8-2
8.1.2 Comparison Output and Comparison Match Signal	8-3
8.1.3 Configuration Using Tool Software	8-3
8.2 Execution Example of Comparison Output Function	8-6
8.2.1 Comparison Output of Counter for External Input	8-6

8.1 Comparison Output Function

8.1 Comparison Output Function

8.1.1 Overview of Comparison Output Function

- The comparison output function is used for comparing the "Counter elapsed value by external input" or "Pulse output counter elapsed value of pulse output/PWM output" to an arbitrary "Comparison output setting value" and outputting the comparison result.
- There are eight points for the comparison result output [CMPx], and the types and channels of compared counters, and the comparison condition can be arbitrarily allocated by the software. Also, all comparison output setting values are set to the same counter, and it can be used as a counter with a maximum of eight steps.
- The conditions of the comparison output are selectable from "ON when elapsed value is larger than or equal to setting value" and "ON when elapsed value is smaller than setting value".

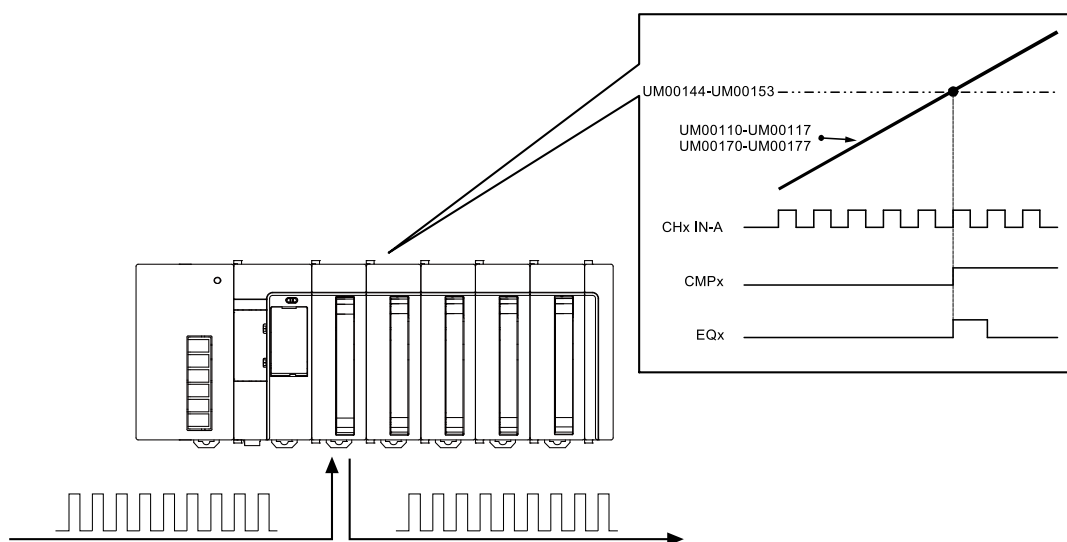

■ Outline of specifications

Item	Specifications	Remarks
No. of comparison outputs	Max. 8 points (CMP0 to CMP7: I/O numbers Y0 to Y7) ^(Note 1)	
Comparison object	"Counter elapsed value by external input" or "Pulse output counter elapsed value of pulse output/PWM output" is compared to an arbitrary setting value.	Settable for each point.
Comparison condition	"ON when elapsed value is smaller than setting value"/"ON when elapsed value is larger than or equal to setting value"	Settable for each point.
Data range	-2147483648 to +2147483647	

(Note 1) I/O numbers vary according to the starting word number of the unit.

i Info.

- When selecting "Compare" in the comparison output setting, "Comparison output setting value" and "Counter elapsed value" are compared whether the counter function is used or not. Note that the output turns on when the comparison output condition is met. Such as when both "Counter initial value" and "Comparison output setting value" are "0".

8.1.2 Comparison Output and Comparison Match Signal

The comparison function provides the following two functions.

■ **Types of measurement function**

Item	Comparison condition	Description
Comparison output (CMPx)	ON when elapsed value is smaller than setting value ON when elapsed value is larger than or equal to setting value	Compares the elapsed value of the high-speed counter and comparison value, and turns on the corresponding output (CMP0-CMP7) when the specified condition is met. The comparison result is output to the external outputs (Y0-Y7) and can be monitored by the internal input signals (X10-X17).
Comparison match signal (Eqx)	ON when elapsed value is equal to setting value	The comparison match signal (EQx) is a signal for the internal processing which is not externally output. Compares the elapsed value of the high-speed counter and a specified comparison value, and turns on when they match. The comparison match signal (EQx) functions as the startup condition of an interrupt program when it is selected as the startup condition of the interrupt function.

8.1.3 Configuration Using Tool Software

The setting of the comparison output function is specified in the configuration menu of FPWIN GR7.

■ **Setting method**

The following procedure describes the process when the multi I/O unit has been already allocated in the I/O map. Set the "Counter (for external input)" or "PLS/PWM output counter" to be compared in advance. The counter can be set for each comparison output.

1 2 Procedure

- Select **Options>Multi I/O Unit Setting** in the menu bar.
The "Multi I/O Unit Setting" dialog box is displayed. Select a unit to be used.
- From the function selection tree, select "Comparison match output", and double-click a comparison match number to which the comparison output is allocated.
The "Comparison Match Output Advanced" dialog box is displayed.
- Check the box for "Compare".

8.1 Comparison Output Function

4. Select a counter to be compared from the pull-down box.
Select High-speed counter (CH0-CH3) or PLS output (PLS0-PLS3).
5. Input the comparison condition and comparison value.
Select either ""ON when elapsed value is smaller than setting value"" or ""ON when elapsed value is larger than or equal to setting value"" for the comparison condition.

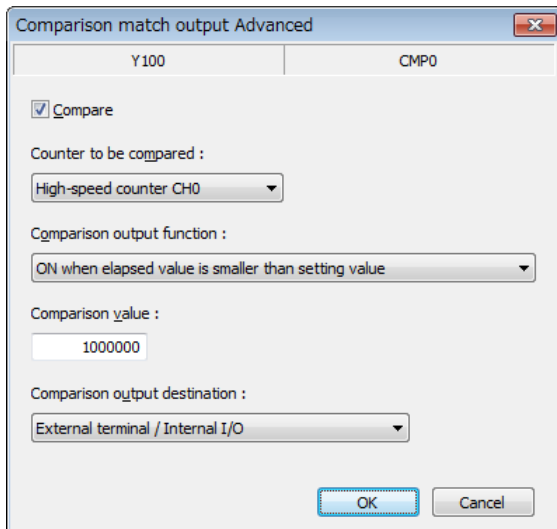

6. Select a comparison output destination.
Select either ""External terminal/Internal I/O"" or ""Internal I/O"".
7. Press the [[OK]] button.
The selected condition will be registered in the ""Multi I/O Unit Setting"" dialog box.
The following figure shows an example of allocating the output compared to ""High-speed counter (Direction distinction)"" to the output (Y100) of the multi I/O unit. The control input for monitoring is automatically allocated to the input (X110) of the unit's internal I/O.

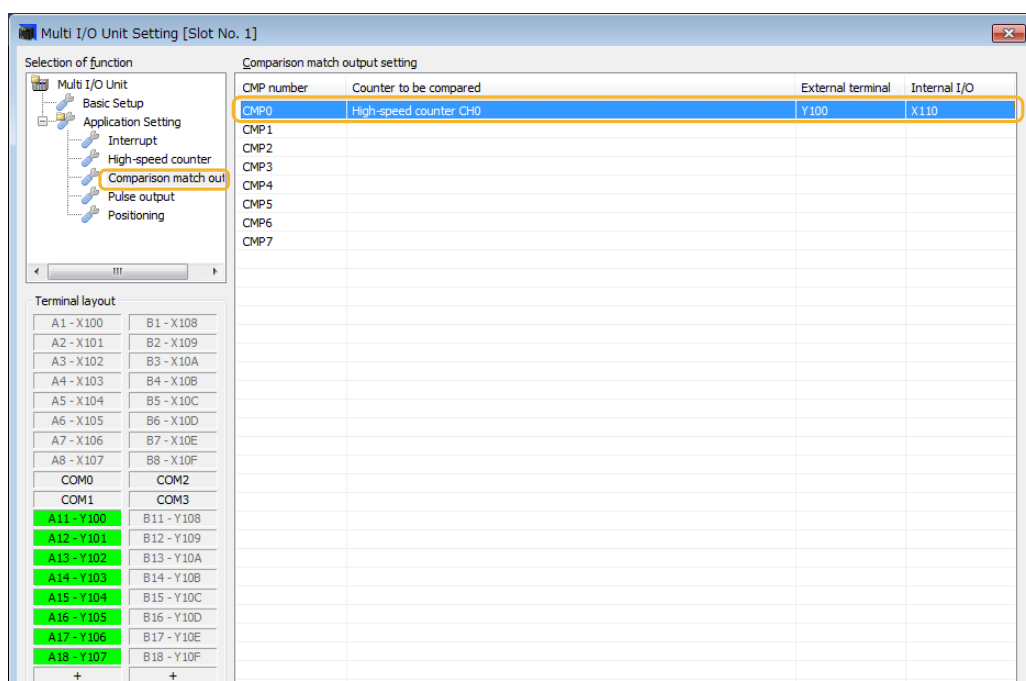

The set values will be effective when they are downloaded with programs or other configuration information as a project.

Note

- Precautions when using FPCWIN GR7 for configuration
On the unit ver.1.0x, internal contacts cannot be set as the comparison output destination. When selecting internal contacts as the comparison output destination on the tool software, the registration of the comparison function is set not to be used.

Info.

- This function can also be set by writing to the comparison output setting area of unit memories with user programs. For details on unit memories, refer to ""13.4.7 Comparison Output Setting Area"".

8.2 Execution Example of Comparison Output Function

8.2 Execution Example of Comparison Output Function

8.2.1 Comparison Output of Counter for External Input

■ Overview

This function is used for comparing the elapsed value of the high-speed counter CH0 for external inputs to ""Comparison output setting value"" specified in advance, and turning on the comparison output (CMP0: output number Y100) when the comparison condition is met.

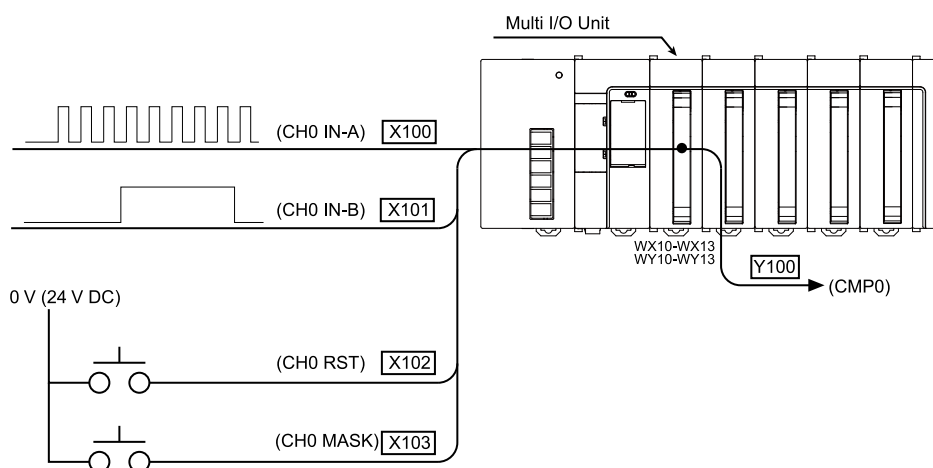

■ Configuration

- Allocate high-speed counter inputs to the inputs (X100-X103), and select ""Direction distinction"".
- Select ""Comparison match output"" in the function selection tree, and double-click the comparison match number CMP0 to open the "Advanced" dialog box.
- Select ""High-speed counter CH0"" as a counter to be compared. Also, select ""ON when elapsed value is smaller than or equal to setting value"" for the comparison output function, and input a comparison value.

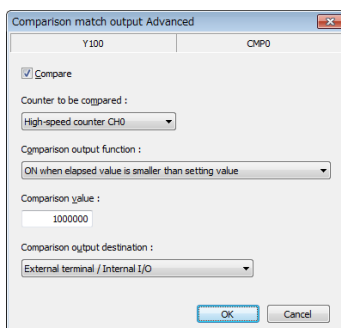
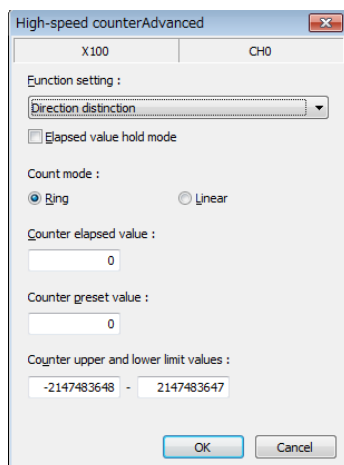

8.2 Execution Example of Comparison Output Function

■ Time chart

- The comparison output (CMP0: output number Y100) turns on when the elapsed value reaches the comparison output setting value and meets the condition which satisfies the comparison condition ""ON when elapsed value is larger than or equal to setting value"".
- The comparison is performed continuously even after turning on the comparison output. The comparison output will turn off when ""Elapsed value is smaller than setting value"" is met.

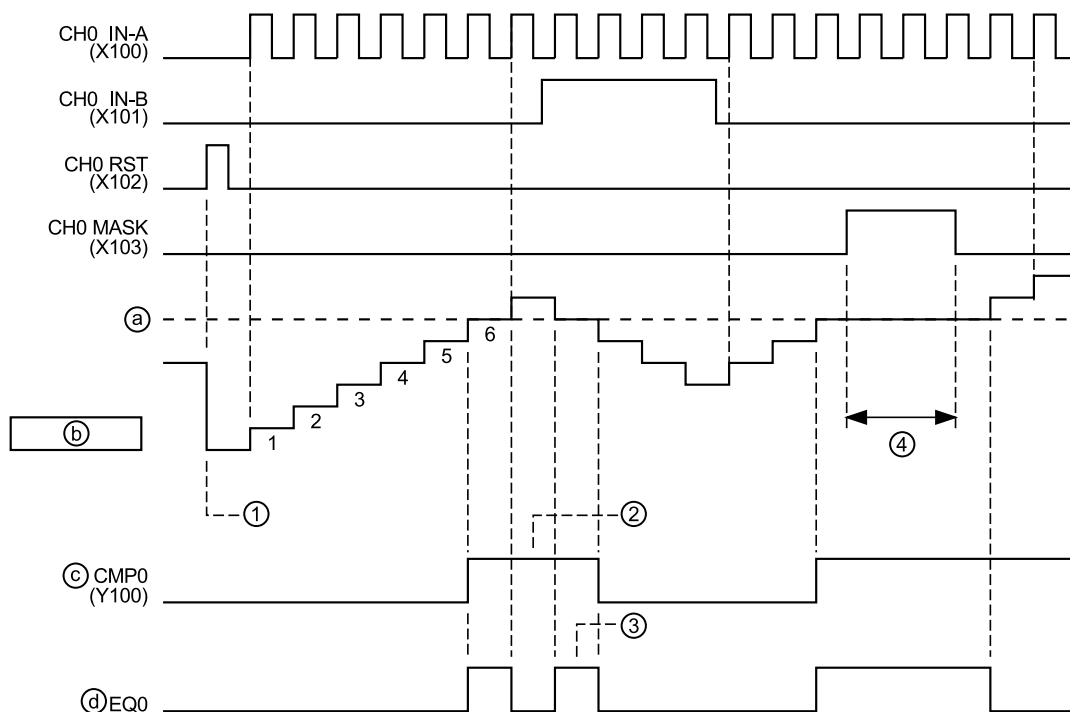

(a)	Comparison output setting value	(1)	The count value is reset when the reset signal turns on.
(b)	Counter elapsed value	(2)	Turns on when the elapsed value is larger than or equal to the setting value. It is output to the output Y100.
(c)	Comparison	(3)	When using this function in combination with the interrupt function, an interrupt occurs by the interrupt occurrence condition when the elapsed value agrees with the comparison output setting value.
(d)	Comparison match (Internal signal)	(4)	Counting is disabled while the mask signal is on.

(MEMO)

9 Pulse Output/PWM Output Function

9.1 Pulse Output / PWM Output Function.....	9-2
9.1.1 Overview of Pulse Output / PWM Output Function.....	9-2
9.1.2 Pulse Output Function Settings	9-2
9.1.3 Pulse Start Logic.....	9-3
9.1.4 Configuration Using Tool Software.....	9-4
9.1.5 Data Update Timing (Output Frequency).....	9-6
9.1.6 Data Update Timing (Duty Ratio).....	9-7
9.2 Control Signals.....	9-10
9.2.1 Enable and Start	9-10
9.2.2 Reset.....	9-10
9.3 Read/Write of PLS/PWM Counter Elapsed Value.....	9-12
9.3.1 Elapsed Value When Power Turns On.....	9-12
9.3.2 Reading PLS/PWM Counter Elapsed Value	9-12
9.3.3 Changing PLS/PWM Counter Elapsed Value	9-12
9.4 Execution Example of Pulse Output / PWM Output Function	9-13
9.4.1 Setting Example of Pulse Output	9-13
9.4.2 Setting Example of Pulse Output (Frequency Change).....	9-14
9.4.3 Setting Example of Pulse Output (Comparison Match Stop).....	9-16
9.4.4 Setting Example of PWM Output	9-18

9.1 Pulse Output / PWM Output Function

9.1 Pulse Output / PWM Output Function

9.1.1 Overview of Pulse Output / PWM Output Function

- The pulse output can be performed up to 500 kHz using the pulse output function, and it can be applied to a simple position control. The output mode can be selected from direction distinction, individual output, phase input, and comparison match stop.
- The PWM output up to 100 kHz can be obtained in the range of 0 to 100% with the PWM output function.
- As the counter for the pulse output/PWM output is also provided, it can be applied to the cases such as switching output frequencies according to the elapsed values.

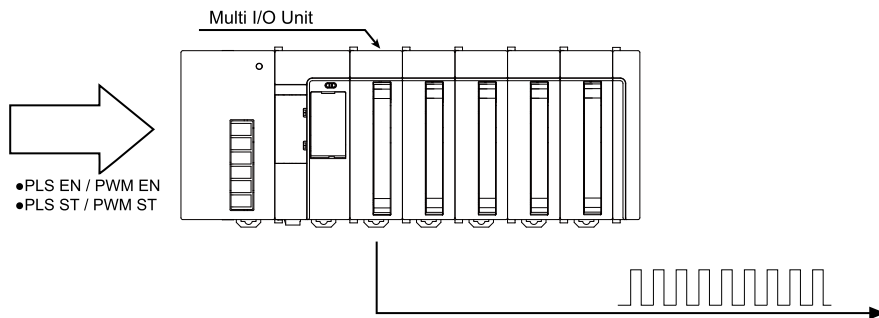

■ Outline of specifications

Item	Specifications
No. of output channels	Max. 4 channels (The total of positioning, pulse output and PWM output)
Output I/O number	Y8 to YF ^(Note 1)
Output frequency	During pulse output: 0 Hz to 500 kHz (Can be set in 1 Hz increments) During PWM output: 0 Hz to 100 kHz (Can be set in 1 Hz increments)
Output duty ratio	During pulse output: 50% (fixed) During PWM output: 0 to 100% (Can be set in 0.1% increments)
Control input	Enable, Start, Counter reset
Pulse output/PWM output counter	To be stored in unit memories (UM) by channel Counting range: -2,147,483,648 to +2,147,483,647 Comparison output setting: Max. 8 points Elapsed value offset function Count upper and lower limit settings

(Note 1) Two outputs are used when using the pulse output function, and one output is used when using the PWM output function.

9.1.2 Pulse Output Function Settings

The following five output modes are provided for the pulse output/PWM output. They can be selected in the configuration menu of FPWIN GR7.

■ Types of pulse output function settings

Setting	Description
PLS output - Direction distinction	This mode is used to perform the pulse output for PLS A and the direction output for PLS B using two outputs. By turning the direction output signal (Y128-12B) on/off using the user program, the output of the terminal allocated to PLS B (Y109/Y10B/Y10D/Y10F) turns on/off.
PLS output - Individual output	This mode is used to use two outputs as the CW output/CCW output. When the direction output signal (Y128-12B) is off, the pulse output is performed from the terminal (Y108/Y10A/Y10C/Y10E) allocated to PLS A. When the direction output signal (Y128-12B) is on, the pulse output is performed from the terminal (Y109/Y10B/Y10D/Y10F) allocated to PLS B.
PLS output - Phase output	This mode is used to perform the phase output by the combination of PLS A and PLS B using two outputs.
PLS output - Comparison match stop	This mode is used in combination with the comparison output function. When the elapsed value (UM00170-UM00177) of the counter for the pulse output/PWM output matches the comparison output setting value (UM00144-UM00153), the pulse output will stop. The pulse output method when selecting the comparison match stop is the individual output. This mode is for using PLS A as CW output and PLS B as CCW output using two outputs.
PWM output	This mode is used to perform the PWM output.

(Note 1) The I/O numbers in the table above are for slot number 1 and the starting word number 10. The I/O numbers actually used vary according to the slot number where the unit is installed and the starting word number.

9.1.3 Pulse Start Logic

On the unit ver.1.10 or later, the pulse start logic can be selected from "OFF start" or "ON start". (On the unit ver.1.0x, it is always "OFF start".)

■ Time chart

In the case of OFF start, the pulse output starts from the OFF period of one-half cycle when a leading edge of the start signal is detected. In the case of ON start, the pulse output starts from the ON period and turns off after the elapse of a half cycle.

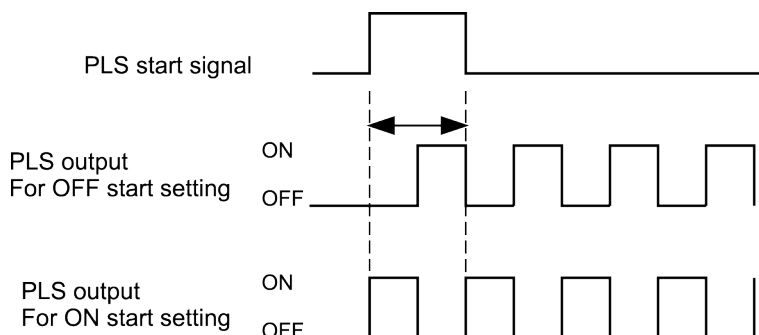

9.1 Pulse Output / PWM Output Function

9.1.4 Configuration Using Tool Software

The setting of the pulse output/PWM output function is specified in the configuration menu of FPWIN GR7.

■ Setting method

The following procedure describes the process when the multi I/O unit has been already allocated in the I/O map.

1 2 Procedure

1. Select **Options>Multi I/O Unit Setting** in the menu bar.
The ""Multi I/O Unit Setting"" dialog box is displayed. Select a unit to be used.
2. From the function selection tree, select ""Pulse output"", and double-click an output number to which the pulse output/PWM output is allocated.
The ""Pulse Output Advanced"" dialog box is displayed.
3. Select a function setting, data update timing, and input a frequency.
When selecting PWM output, set a duty ratio. Set the upper and lower limit values of the counter for the pulse output/PWM output according to applications.

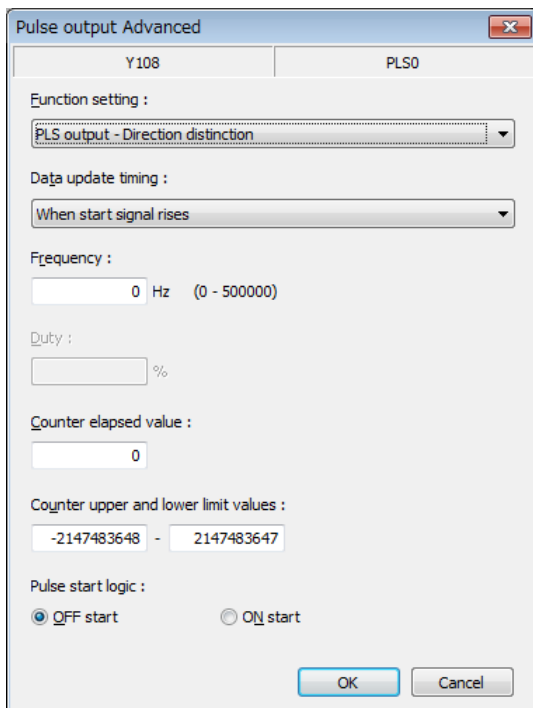

4. Select a pulse start logic.
Select either ""OFF start"" or ""ON start"".
5. Press the [[OK]] button.
The selected condition will be registered in the ""Multi I/O Unit Setting"" dialog box.

The following figure shows the example of allocating ""Pulse output (Direction distinction)"" to the outputs (Y108-Y109) of the multi I/O unit. The control inputs for monitoring are allocated to the inputs of the unit internal I/O (X118-X119), and the control output is allocated to the outputs (Y118/Y119C/Y128/Y12C) automatically.

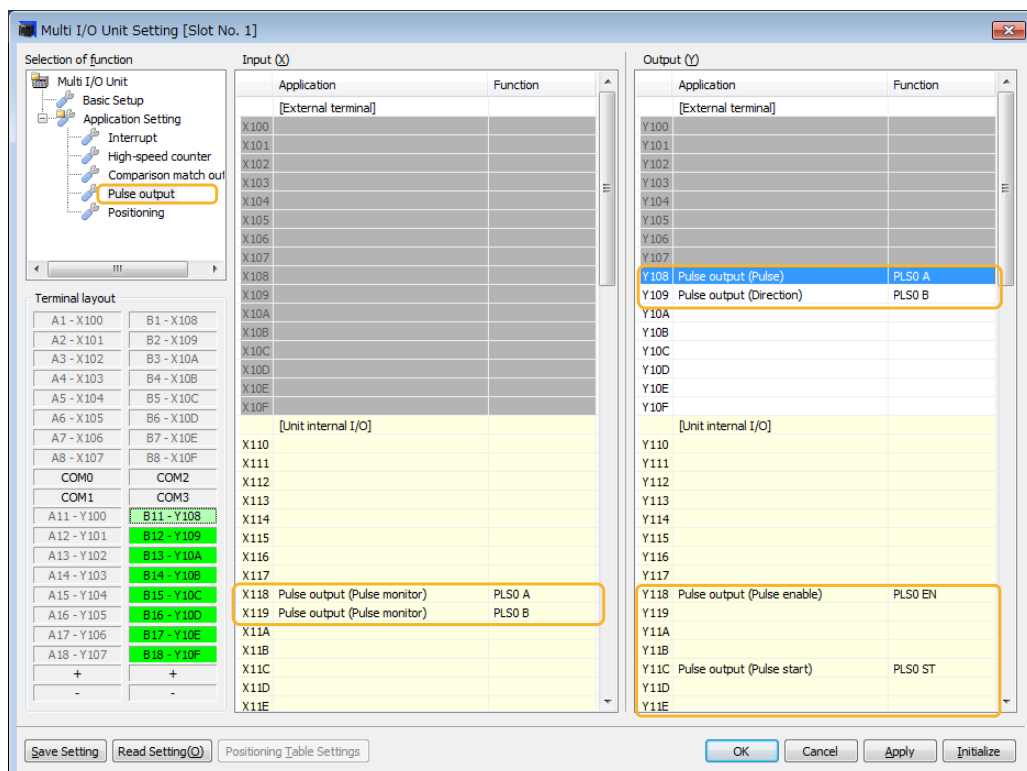

The set values will be effective when they are downloaded with programs or other configuration information as a project.

Setting of counter elapsed value

The values set in the ""Pulse Output Advanced"" dialog box are applied as follows.

Item	Operation	Related unit memory
PLS/PWM counter elapsed value	The value set in the ""Counter elapsed value"" in the dialog box is set in the PLS/PWM counter elapsed value area after switching the mode to RUN mode.	UM00170-UM00177

(Note 1) The values in ""PLS/PWM counter elapsed value area"" of the channel to which the positioning function has been set with the H type are the same as the values in ""Positioning elapsed value (current value) area"".

i Info.

- This function can also be set by writing to unit memories with user programs. For details on unit memories, refer to ""13.4.8 Pulse Output / PWM Output Setting Area"".

9.1 Pulse Output / PWM Output Function

9.1.5 Data Update Timing (Output Frequency)

The following three modes are provided for the both pulse output and PWM output as the timing of changing the data of output frequencies.

■ Updating data when PLS start signal rises

In this mode, the data update is performed with the data when a PLS start signal turns on. The frequency value changed at this timing will be reflected when the outputting pulse falls next time.

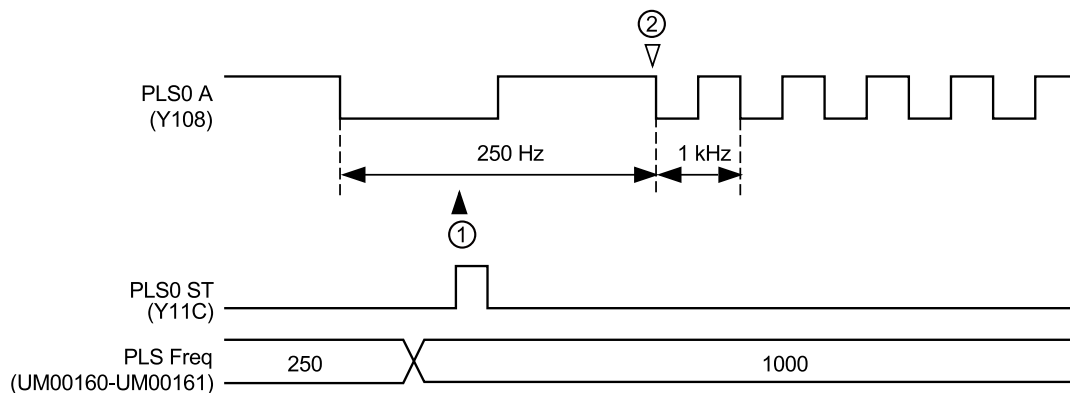

(Note 1) In this time chart, "OFF start" is selected for the pulse start logic.

■ Updating data when comparison output is performed

In this mode, the data update is performed with the data when the counter elapsed value matches the comparison value. The frequency value changed at this timing will be reflected when the outputting pulse falls next time.

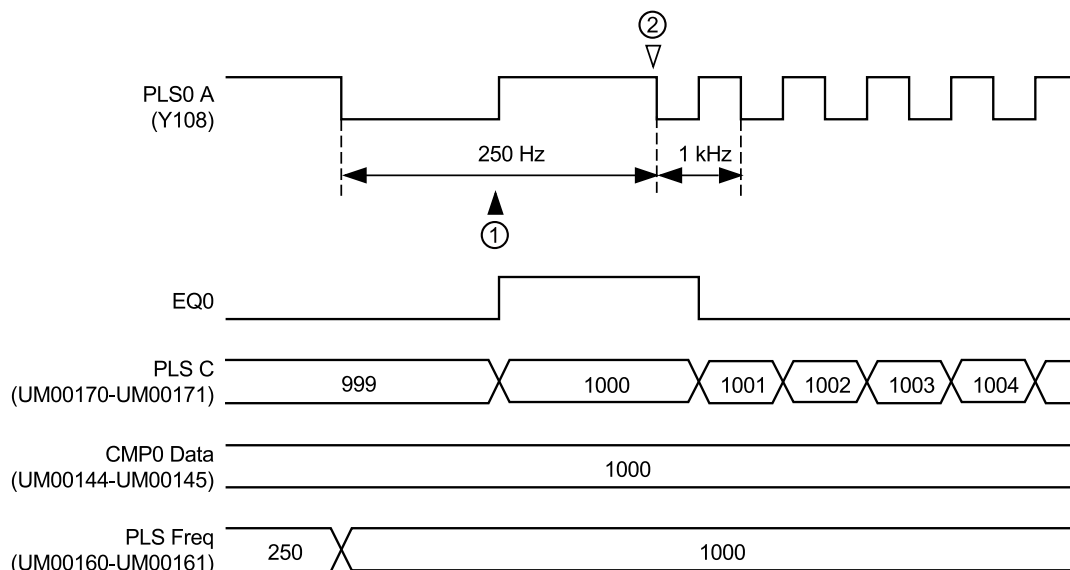

(Note 1) In this time chart, "OFF start" is selected for the pulse start logic.

■ Updating data when unit memory (UM) is rewritten

This mode updates using data as of when the unit memory (UM) was written. The frequency value changed at this timing will be reflected when the outputting pulse falls next time.

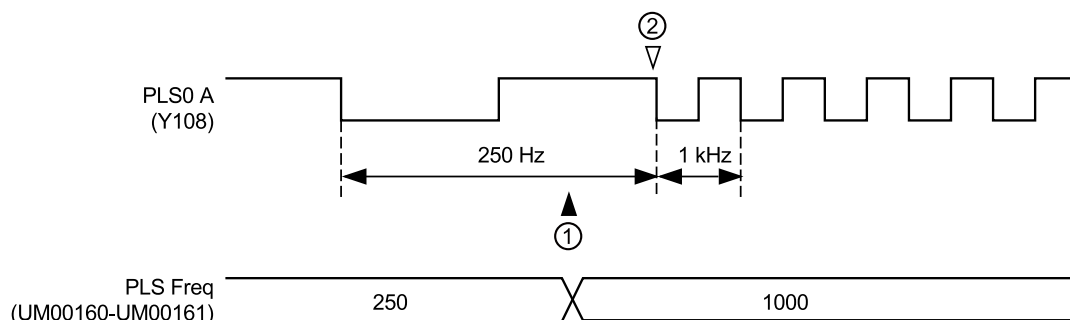

Mark	Procedure	Description
(1)	Data update timing	It indicates the timing at which the data of the unit memory (UM) where PLS/PWM output frequency is stored is reflected.
(2)	Output update timing	It indicates the timing at which the changed PLS/PWM output frequency is reflected as an actual output.

■ I/O allocation

Signal name	CH0	CH1	CH2	CH3
PLS output A	Y109	Y10A	Y10C	Y10E
PLS output B	X109	Y10B	Y10D	Y10F
PWM output	Y109	Y10A	Y10C	Y10E

(Note 1) The I/O numbers in the table above are for slot number 1 and the starting word number 10. The I/O numbers actually used vary according to the slot number where the unit is installed and the starting word number.

■ Unit memory (UM) allocation

Signal name	CH0	CH1	CH2	CH3
PLS/PWM frequency area	UM00160-UM00161	UM00162-UM00163	UM00164-UM00165	UM00166-UM00167
PLS/PWM counter elapsed value area	UM00170-UM00171	UM00172-UM00173	UM00174-UM00175	UM00176-UM00177

(Note 1) The values in ""PLS/PWM counter elapsed value area"" of the channel to which the positioning function has been set with the H type are the same as the values in "Positioning elapsed value (current value) area".

9.1.6 Data Update Timing (Duty Ratio)

The following three modes are provided as the timing of changing the data of duty ratio at the time of PWM output.

9.1 Pulse Output / PWM Output Function

■ Updating data when PLS start signal rises

In this mode, the data update is performed with the data when a PLS start signal turns on. The frequency value changed at this timing will be reflected when the outputting pulse falls next time.

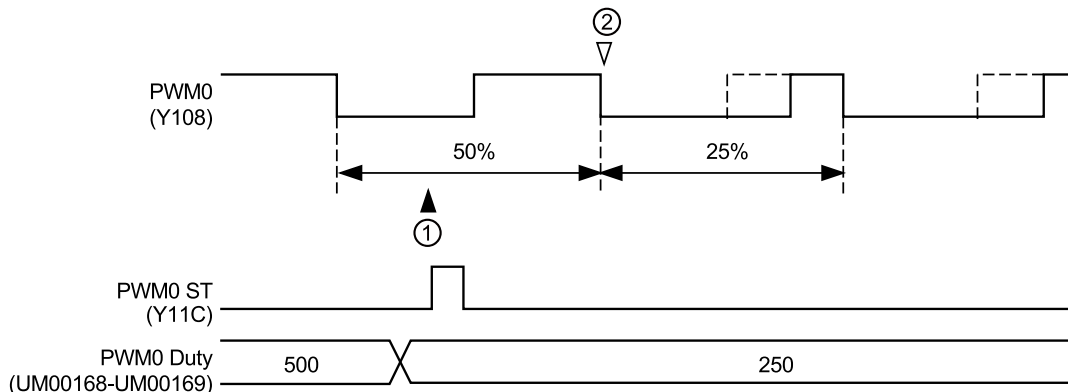

■ Updating data when comparison output is performed

In this mode, the data update is performed with the data when the counter elapsed value matches the comparison value. The frequency value changed at this timing will be reflected when the outputting pulse falls next time.

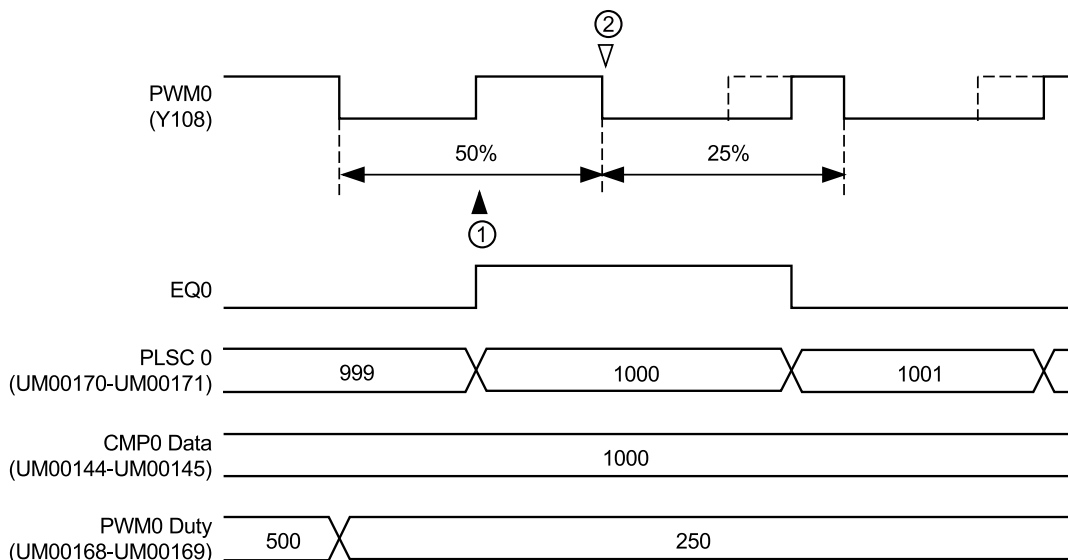

■ Updating data when unit memory (UM) is rewritten

This mode updates using data as of when the unit memory (UM) was written. The frequency value changed at this timing will be reflected when the outputting pulse falls next time.

9.1 Pulse Output / PWM Output Function

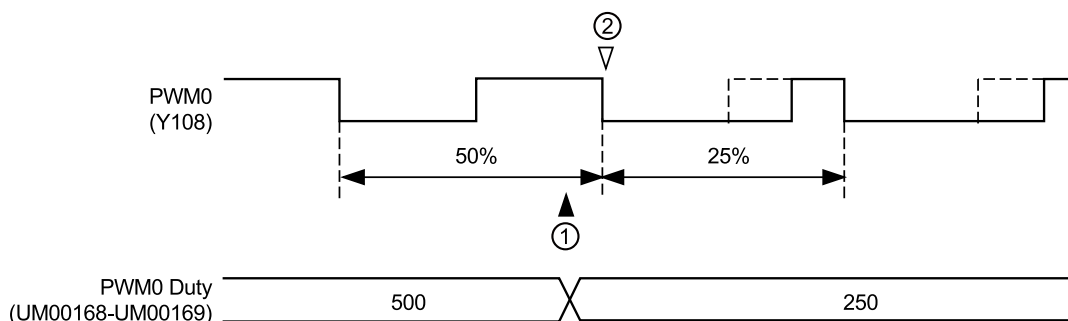

Mark	Procedure	Description
(1)	Data update timing	It indicates the timing at which the data of the unit memory (UM) where PWM output duty ratio is stored is reflected.
(2)	Output update timing	It indicates the timing at which the changed PWM output duty ratio is reflected as an actual output.

■ I/O allocation

Signal name	CH0	CH1	CH2	CH3
PWM output	Y109	Y10A	Y10C	Y10E

(Note 1) The I/O numbers in the table above are for slot number 1 and the starting word number 10. The I/O numbers actually used vary according to the slot number where the unit is installed and the starting word number.

■ Unit memory (UM) allocation

Signal name	CH0	CH1	CH2	CH3
PWM duty area	UM00168-UM00169	UM0016A-UM0016B	UM0016C-UM0016D	UM0016E-UM0016F
PLS/PWM counter elapsed value area	UM00170-UM00171	UM00172-UM00173	UM00174-UM00175	UM00176-UM00177

(Note 1) The values in the "PLS/PWM counter elapsed value area" of the channel to which the positioning function has been set with the H type are the same as the values in the "Positioning elapsed value (current value) area".

9.2 Control Signals

9.2 Control Signals

9.2.1 Enable and Start



The pulse output/PWM output function is controlled by user programs.

■ Functions of each signal

Signal name	Description
Enable PLSx EN PWMx EN	<ul style="list-style-type: none"> Enables or disables the pulse output/PWM output function. If this signal turns off during the output, the pulse output/PWM output will stop.
Start PLSx ST PWMx ST	<ul style="list-style-type: none"> Starts the pulse output/PWM output when the enable signal is valid. When this signal turns on during the execution of the pulse output/PWM output, the frequency will be changed.

(Note 1) If the enable signal turns on when the start signal is on, this is interpreted as the start signal also turning off > on, and the pulse output will start or the frequency will be changed.

■ I/O allocation (Control by programs)

Signal name	Valid Condition	PLS0	PLS1	PLS2	PLS3
		PWM0	PWM 1	PWM 2	PWM 3
Enable PLSx EN PWMx EN	Level 	Y118	Y119	Y11A	Y11B
Start PLSx ST PWMx ST	ON edge 	Y11C	Y11D	Y11E	Y11F

(Note 1) The I/O numbers in the table above are for slot number 1 and the starting word number 10. The I/O numbers actually used vary according to the slot number where the unit is installed and the starting word number.

9.2.2 Reset

- With the counter for the pulse output/PWM output, the reset operation by user programs can be performed.
- The PLS/PWM counter elapsed value area (UM00170-UM00177) is reset to ""0"" by the reset operation.

■ I/O allocation (Control by programs)

Signal name	Valid Condition	CH0	CH1	CH2	CH3
Reset PLSx CNT RST	Level 	Y12C	Y12D	Y12E	Y12F

(Note 1) The I/O numbers in the table above are for slot number 1 and the starting word number 10. The I/O numbers actually used vary according to the slot number where the unit is installed and the starting word number.

(Note 2) The "PLS/PWM counter elapsed value" area of the channel to which the positioning function has been set with the H type cannot be reset by the above operation.

9.3 Read/Write of PLS/PWM Counter Elapsed Value

9.3 Read/Write of PLS/PWM Counter Elapsed Value

9.3.1 Elapsed Value When Power Turns On

- The default for the elapsed value when the power turns on is "0".
- The count value when the power turns on can be set to any value as necessary. It can be set to an arbitrary value in the configuration menu of the tool software or user programs.

9.3.2 Reading PLS/PWM Counter Elapsed Value

The elapsed value can be read from the unit memory area.

Example) Program to read the elapsed value of the counter CH0 for pulse output/PWM output

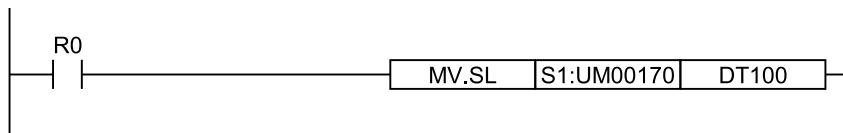

9.3.3 Changing PLS/PWM Counter Elapsed Value

The elapsed value can be set to an arbitrary value using a user program as necessary.

Example) Program to change the elapsed value of the counter CH0 for pulse output/PWM output to 100000

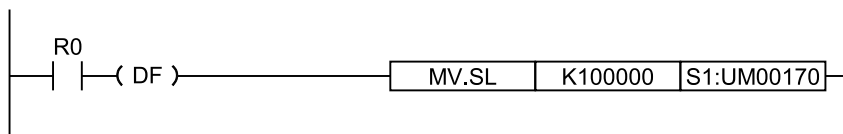

■ Unit memory (UM) allocation

Signal name	CH0	CH1	CH2	CH3
PLS/PWM counter elapsed value area	UM00170-UM00171	UM00172-UM00173	UM00174-UM00175	UM00176-UM00177

(Note 1) Values cannot be written into the "PLS/PWM counter elapsed value" area of the channel to which the positioning function has been set for the H type.

9.4 Execution Example of Pulse Output / PWM Output Function

9.4.1 Setting Example of Pulse Output

■ Overview

The pulse output is performed in the direction distinction mode. It is controlled by the switch input (X140/X141/X142) connected to the 32-point input unit. If the start input (X141) turns on when the enable input (X140) is on, the pulse output will start. The pulse output is switched to that of the reverse direction by turning on X142.

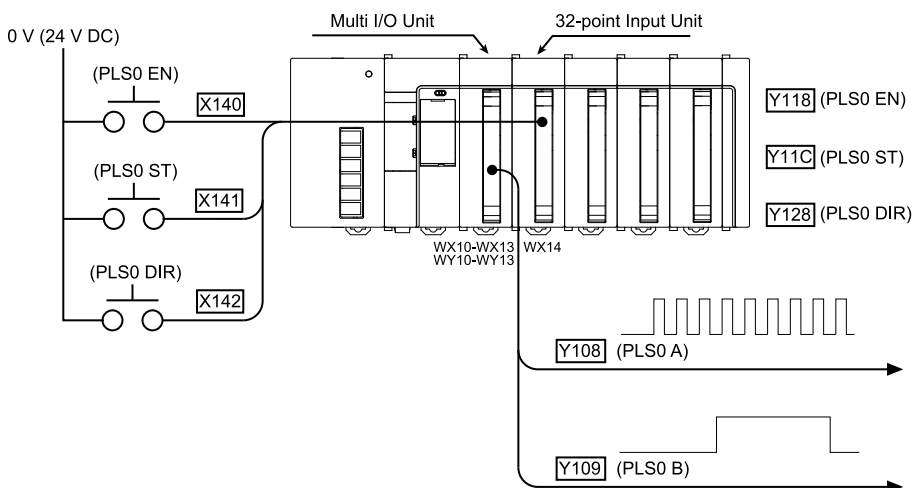

■ Configuration

- Set the pulse output to the outputs (Y108-Y109).
- Select "PLS output - Direction distinction" in the "Pulse Output Advanced" dialog box, and input a frequency.
- Select "When start signal rises" for the data update timing.

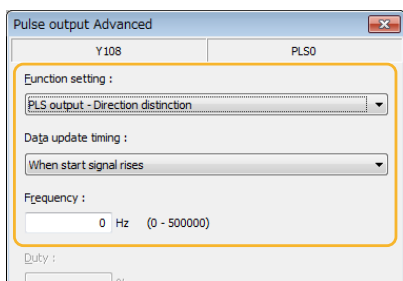

■ Time chart

If the rising of the start signal is detected when the enable input is on, pulses will be output. When the enable input turns off, the pulse output will stop.

9.4 Execution Example of Pulse Output / PWM Output Function

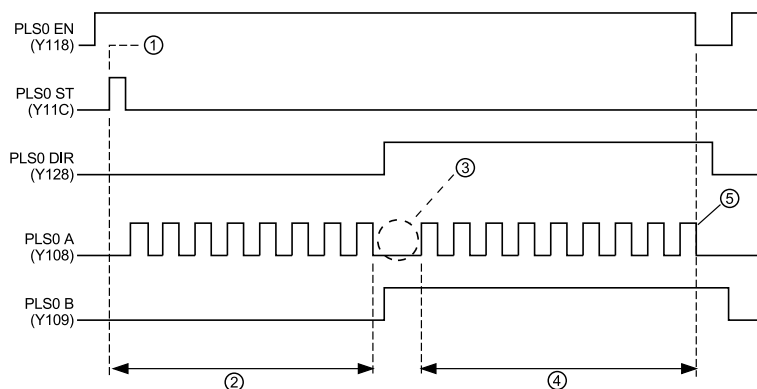

(1)	If the rising edge of the start signal is detected when the enable signal is on, pulses will be output.
(2)	The forward rotation pulse is output.
(3)	One pulse is omitted when the direction is switched.
(4)	The reverse rotation pulse is output.
(5)	When the enable signal turns off, the pulse output will turn off.

(Note 1) In this time chart, "OFF start" is selected for the pulse start logic.

■ Sample program

The external inputs (X140, X141, X142) are allocated to the enable (Y118), start (Y11C) and direction switching (Y128) signals of pulse output respectively.

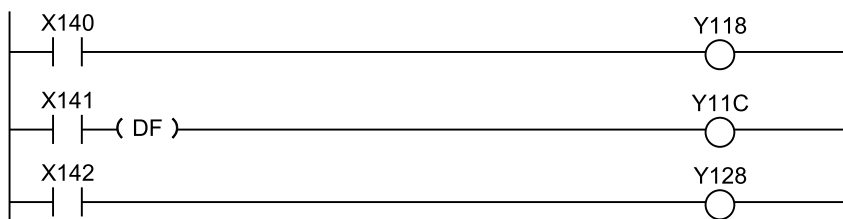

9.4.2 Setting Example of Pulse Output (Frequency Change)

■ Overview

The pulse output is performed in the direction distinction mode. It is controlled by the switch input (X140/X141/X142/X143) connected to the 32-point input unit. If the start input (X141) turns on when the enable input (X140) is on, the pulse output will start. The pulse output is switched to that of the reverse direction by turning on the direction switching input (X142). While the speed change input (X143) is on, the frequency of output pulse is changed.

9.4 Execution Example of Pulse Output / PWM Output Function

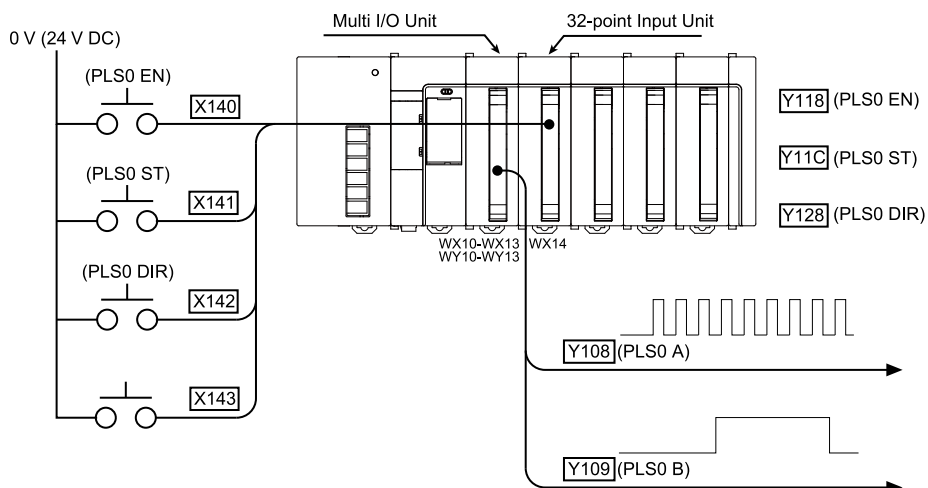

■ Configuration

- Set the pulse output to the outputs (Y108-Y109).
- Select "PLS output - Direction distinction" in the "Pulse Output Advanced" dialog box, and input a frequency.
- Select "When start signal rises or when data is updated" for the data update timing.

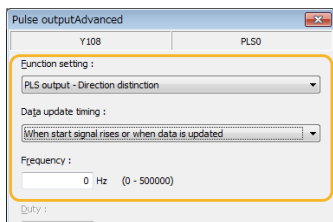

■ Time chart

If the rising of the start signal is detected when the enable input is on, pulses will be output. When the enable input turns off, the pulse output will stop. The speed changes according to the speed change input.

9.4 Execution Example of Pulse Output / PWM Output Function

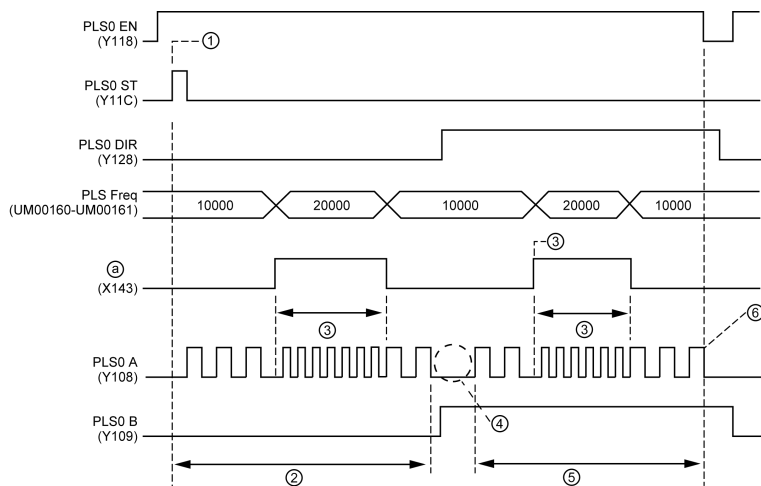

(a)	Speed change input
(1)	If the rising edge of the start signal is detected when the enable signal is on, pulses will be output.
(2)	The forward rotation pulse is output.
(3)	The output frequency is changed while the speed change input is on.
(4)	One pulse is omitted when the direction is switched.
(5)	The reverse rotation pulse is output.
(6)	When the enable signal turns off, the pulse output will turn off.

■ Sample program

The external inputs (X140, X141, X142) are allocated to the enable (Y118), start (Y11C), direction switching (Y128) and speed change signals of pulse output respectively.

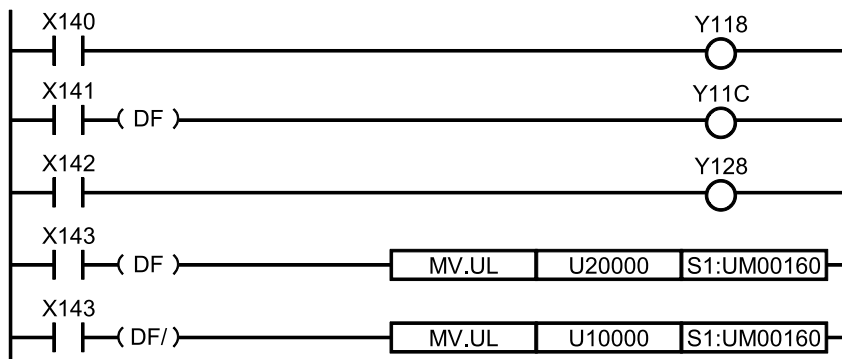

9.4.3 Setting Example of Pulse Output (Comparison Match Stop)

■ Overview

The pulse output is performed in the individual output mode. It is controlled by the switch input (X140/X141) connected to the 32-point input unit. If the start input (X141) turns on when the

9.4 Execution Example of Pulse Output / PWM Output Function

enable input (X140) is on, the pulse output will start. When the value of the pulse output counter reaches the comparison output setting value, the pulse will stop.

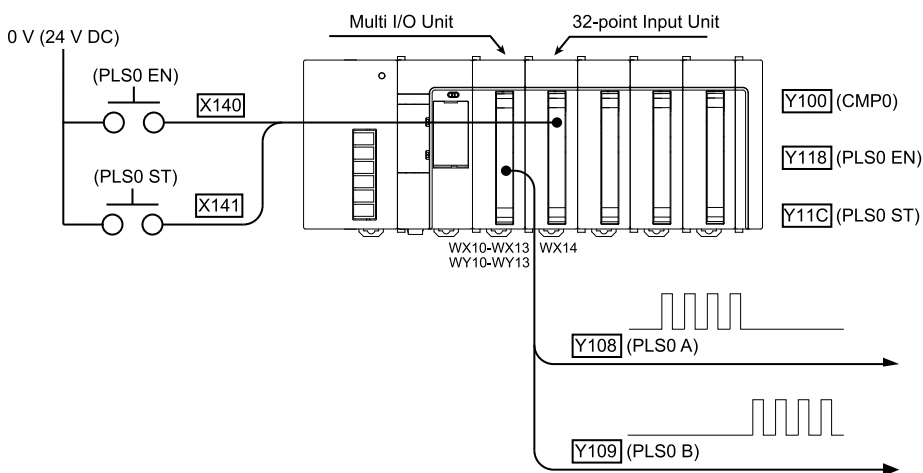

■ Configuration

- Set the pulse output to the outputs (Y108-Y109).
- Select "PLS output - Comparison match stop" in the "Pulse Output Advanced" dialog box, and input a frequency.
- Select "When start signal rises" for the data update timing.
- Select "Comparison match output" in the function selection tree, and double-click the comparison match number CMP0 to open the "Advanced" dialog box.
- In the "Advanced Setting" dialog box, select "Pulse output PLS0" and "ON when elapsed value is larger than or equal to setting value", and input a comparison value.

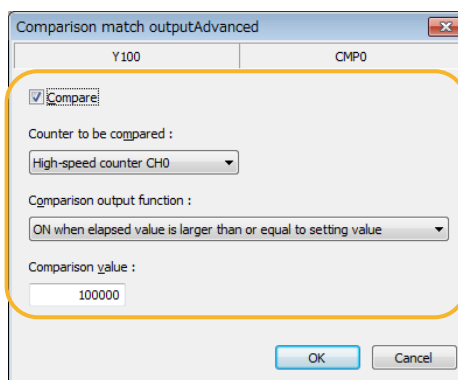
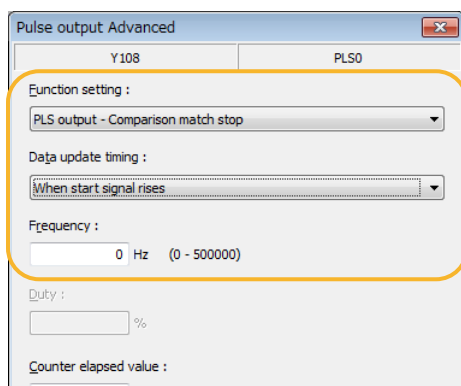

■ Time chart

If the rising of the start signal is detected when the enable input is on, pulses will be output. The pulse output counter reaches the comparison value, the pulse output will stop.

9.4 Execution Example of Pulse Output / PWM Output Function

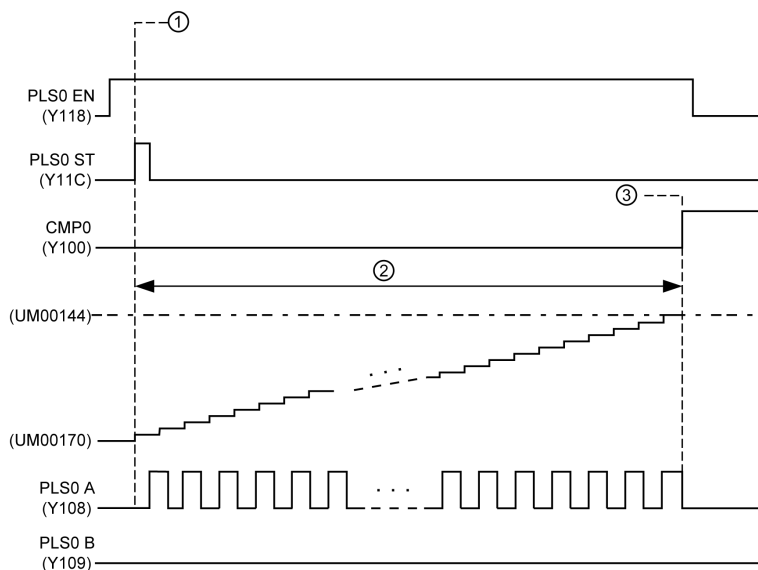

(1)	If the rising edge of the start signal is detected when the enable signal is on, pulses will be output.
(2)	The pulse is output.
(3)	When the comparison output turns on, the pulse output will stop. Also, when the enable signal turns off, the pulse output will turn off.

■ Sample program

The external inputs (X140, X141) are allocated to the enable (Y118) and start (Y11C) signals of pulse output respectively.

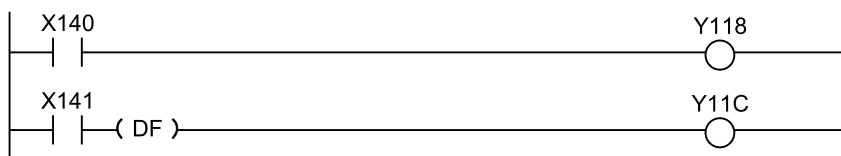

9.4.4 Setting Example of PWM Output

■ Overview

The PWM output is performed. It is controlled by the switch input (X140/X141) connected to the 32-point input unit. If the start input (X141) turns on when the enable input (X140) is on, the PWM output will start.

9.4 Execution Example of Pulse Output / PWM Output Function

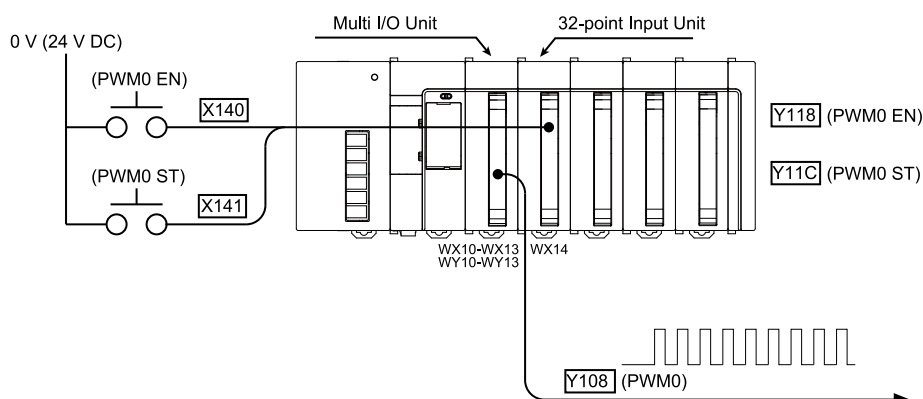

■ Configuration

- Set the PWM output to the output (Y108).
- Select "PWM output" in the "Pulse Output Advanced" dialog box, and input the frequency and duty.
- To change the frequency or duty ratio during the output, from data update timing, select "When start signal rises or when data is updated" or "When start signal rises or when comparison output is performed".

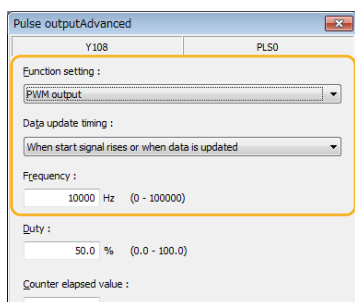

■ Time chart

If the rising of the start signal is detected when the enable input is on, pulses will be output. When the enable input turns off, the pulse output will stop.

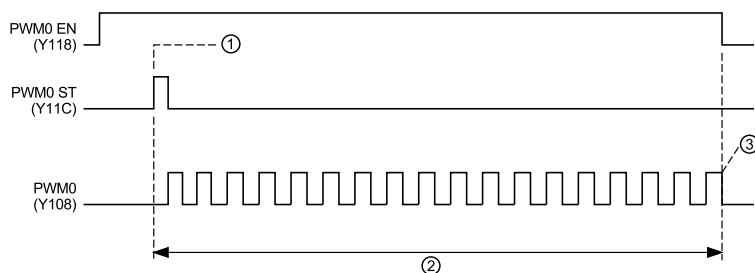

(1)	If the rising edge of the start signal is detected when the enable signal is on, pulses will be output.
(2)	Pulse output with a duty ratio of 50%.
(3)	When the enable signal turns off, the pulse output will turn off.

(Note 1) The pulse output starts in the OFF period.

9.4 Execution Example of Pulse Output / PWM Output Function

■ Sample program

The external inputs (X140, X141) are allocated to the enable (Y118) and start (Y11C) signals of PWM output respectively.

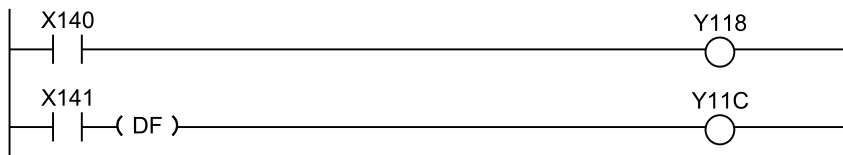

10 Positioning Function (H type)

10.1 Positioning Function.....	10-3
10.1.1 Overview of Positioning Function.....	10-3
10.1.2 Control Mode	10-4
10.2 Wiring.....	10-6
10.2.1 Connection Diagram with Servo Motor Amplifier	10-6
10.2.2 Connections with Servo Motor Amplifier	10-9
10.2.3 Connection with Stepping Motor Driver	10-9
10.3 Initial Operation Check.....	10-11
10.3.1 Safety Circuit Design	10-11
10.3.2 Before Turning On the Power	10-12
10.3.3 Power-on and Power-off Sequences	10-13
10.3.4 After Turning On the Power	10-13
10.4 Setting of Positioning Function	10-15
10.4.1 I/O Allocation of Positioning Function	10-15
10.4.2 Configuration Using Tool Software.....	10-16
10.5 Positioning Table Settings (Configurator PMX).....	10-20
10.5.1 Used Channel Setting	10-20
10.5.2 Parameter Settings	10-22
10.5.3 Creating Positioning Data Table.....	10-24
10.5.4 Saving Positioning Parameters	10-27
10.5.5 Export and Import	10-28
10.5.6 Check on Parameter Data	10-28
10.5.7 Writing Parameters to Unit.....	10-29
10.6 Read/Write of Elapsed Value	10-30
10.6.1 Elapsed Value (Current Value) Area	10-30
10.6.2 Reading Elapsed Value (Current Value) Area.....	10-30
10.7 Stop Control	10-31
10.7.1 Type of stop operations.....	10-31
10.7.2 Characteristics of Stop Operations	10-32
10.8 JOG operation.....	10-34
10.8.1 Setting and Operation of JOG Operation	10-34
10.8.2 Setting and Operation of JOG Operation (Speed Changes).....	10-36
10.8.3 Speed Changes in JOG Operation	10-39
10.9 Home Return.....	10-40
10.9.1 Types of Home Return	10-40
10.9.2 Operation Patterns of Home Return Operation.....	10-41
10.9.3 Settings and Operations of Home Return	10-43

10 Positioning Function (H type)

10.10 Positioning Control.....	10-47
10.10.1 Types of Positioning Controls	10-47
10.10.2 E-point Control (Single Speed Positioning).....	10-48
10.10.3 P-point Control (Double Speed Positioning)	10-50
10.10.4 C-point control.....	10-52
10.10.5 J-point Control (JOG Positioning)	10-54
10.10.6 J-point Control (JOG Positioning: Speed Changes)	10-57
10.10.7 Programming Cautions	10-60
10.11 Repeat Operation.....	10-61
10.11.1 Overview of Repeat Operation	10-61
10.11.2 Settings and Operations of Repeat Operation	10-62
10.11.3 Stop Operation During Repeat Operation	10-64
10.12 Linear Interpolation Control	10-66
10.12.1 Overview	10-66
10.12.2 Setting and Operation of Linear Interpolation	10-66
10.13 Operational Difference Between Speed Parameters	10-69
10.13.1 Startup speed.....	10-69
10.13.2 Operation Patterns and Start Speed Settings.....	10-69
10.14 Other Characteristics	10-71
10.14.1 Memory Backup	10-71
10.14.2 Activation of Each Operation	10-71
10.14.3 Operation When CPU Mode Changes From RUN To PROG.	10-71

10.1 Positioning Function

10.1.1 Overview of Positioning Function

The positioning control can be performed when the unit is used in combination with a stepping motor or servo motor equipped with a driver of pulse string input type.

- Up to twenty positioning data tables for each channel are provided in configuration software ""Configurator PMX"", and can be allocated to arbitrary positioning controls (E-point control/P-point control/C-point control/J-point control).
- Positioning controls can be executed by specifying positioning data table numbers with user programs.

Position unit: pulse Speed unit: pulse / s

Table number	Operation p...	Control method	X axis (CH0)...	Accelerati...	Acceleration ...	Deceleration ...	Target ...	Dwell time (ms)
1	E: End point	I Increment	10000	L: Linear	100	200	20000	50
2	P: Pass point	I Increment	5000	L: Linear	100	200	20000	0
3	E: End point	I Increment	10000	L: Linear	150	250	10000	50

- JOG operation, five kinds of home return operations and four kinds of stop controls are also supported.
- Positioning parameters and data of positioning data tables can be set using configuration software ""Configurator PMX"". ""Configurator PMX"" is started from the "Options" menu of FPCWIN GR7.

■ Operation image

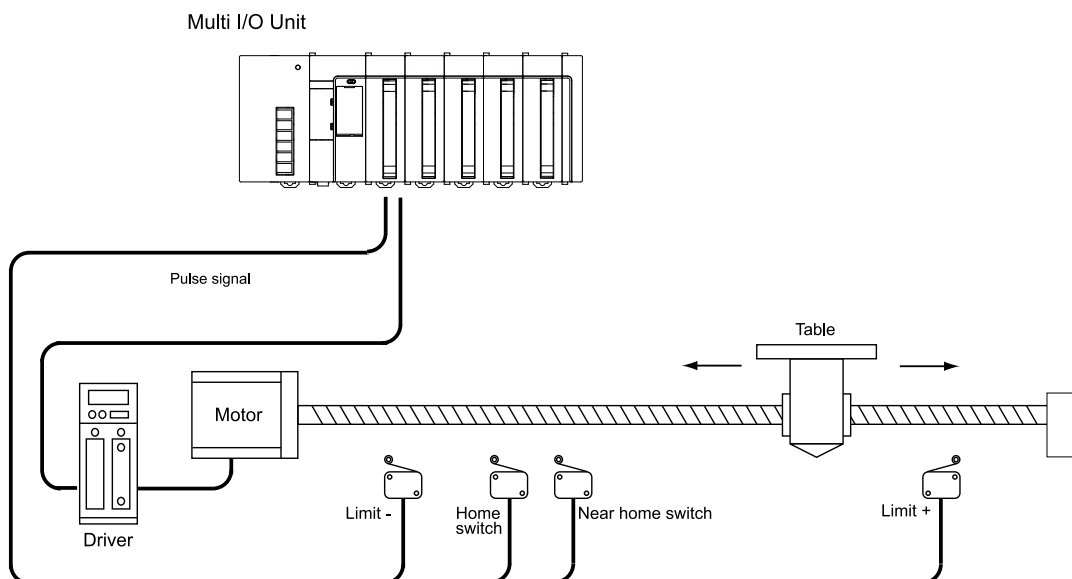

10.1 Positioning Function

■ Outline of specifications

Item	Specifications	Remarks
No. of output channels	Max. 4 channels (The total of positioning, pulse output and PWM output)	
Occupied I/O numbers	X0 to XF, Y4 to YF ^(Note 1)	Per unit
Control input	Home input, Near home input, Limit + input, Limit - input, J-point control positioning start input	Per channel
Control output	Pulse output: 2 points (CW/CCW or Pulse/Sign) Deviation counter clear output: 1 point	Per channel
Position command	-2147483648 to +2147483647	
Speed command (Pulse output frequency)	1 to 500000 (1 Hz to 500 kHz)	
Control Mode	Positioning control (E-point control/P-point control/C-point control/J-point control) JOG operation, home return, stop	

(Note 1) The I/O numbers actually used vary according to the slot number where the unit is installed and the starting word number. As for the near home input and J-point control positioning start input, either of them can be selected and allocated.

10.1.2 Control Mode

There are mainly four control modes.

■ Control mode type

Item	Description	Related page
Positioning Control	<p>There are four modes, E-point control, P-point control, C-point control and J-point control. Each control is executed by turning on an allocated output (Y30-Y34) using user programs.</p> <p>E-point control: Executes a trapezoidal control. Performs a single-speed acceleration/ deceleration control.</p> <p>P-point control: Executes a trapezoidal control. Performs a multispeed acceleration/ deceleration control.</p> <p>C-point control: Executes multiple trapezoidal controls continuously.</p> <p>J-point control: Executes a position control by a timing input (position control start input) after the start of speed control.</p>	"P.10-47"
JOG operation	JOG operation is executed while an allocated output (Y3C-Y43) is on using user programs. The speed can be changed after starting the JOG operation.	"P.10-34"
Home Return	There are five modes which correspond to various system configurations, such as home return, near home input and limit input. Each control is	"P.10-40"

Item	Description	Related page
	executed by turning on an allocated output (Y38-Y3B) using user programs.	
Stop	<p>There are four modes, system stop, emergency stop, limit stop and deceleration stop. Each control is executed by turning on an allocated output (Y44-Y4F) using user programs. (Except limit stop)</p> <p>System stop: Stops all channels without deceleration time.</p> <p>Emergency stop: Stops each channel using a set ""emergency stop time"".</p> <p>Limit stop: Stops at the time of limit input using a set ""limit stop time"".</p> <p>Deceleration stop: Stops each channel using a set ""deceleration time"".</p>	"P.10-31"

10.2 Wiring

10.2.1 Connection Diagram with Servo Motor Amplifier

■ Connection example using sink output

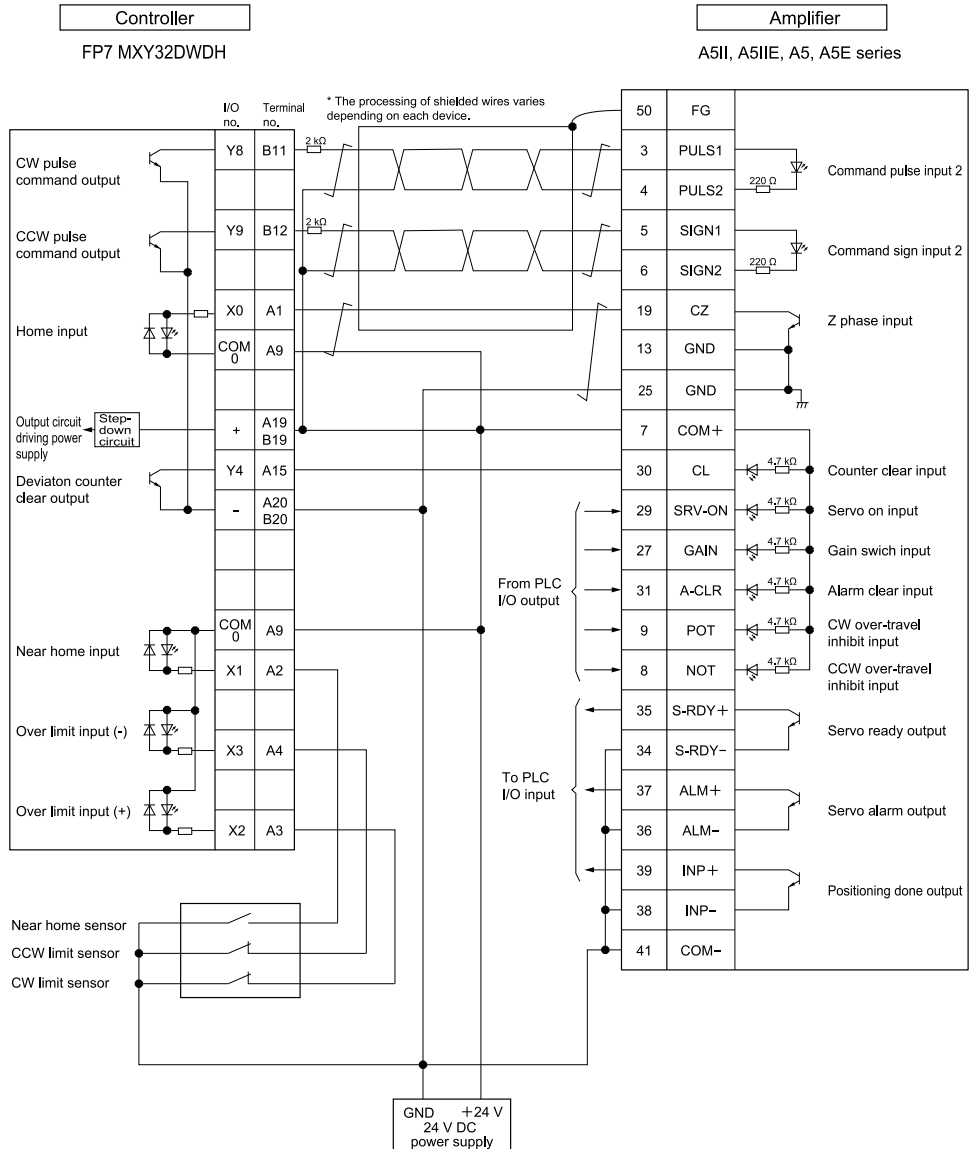

(Note 1) The allocation of I/O numbers on the controller side depends on the unit settings.

■ Connection example using push-pull negative logic output

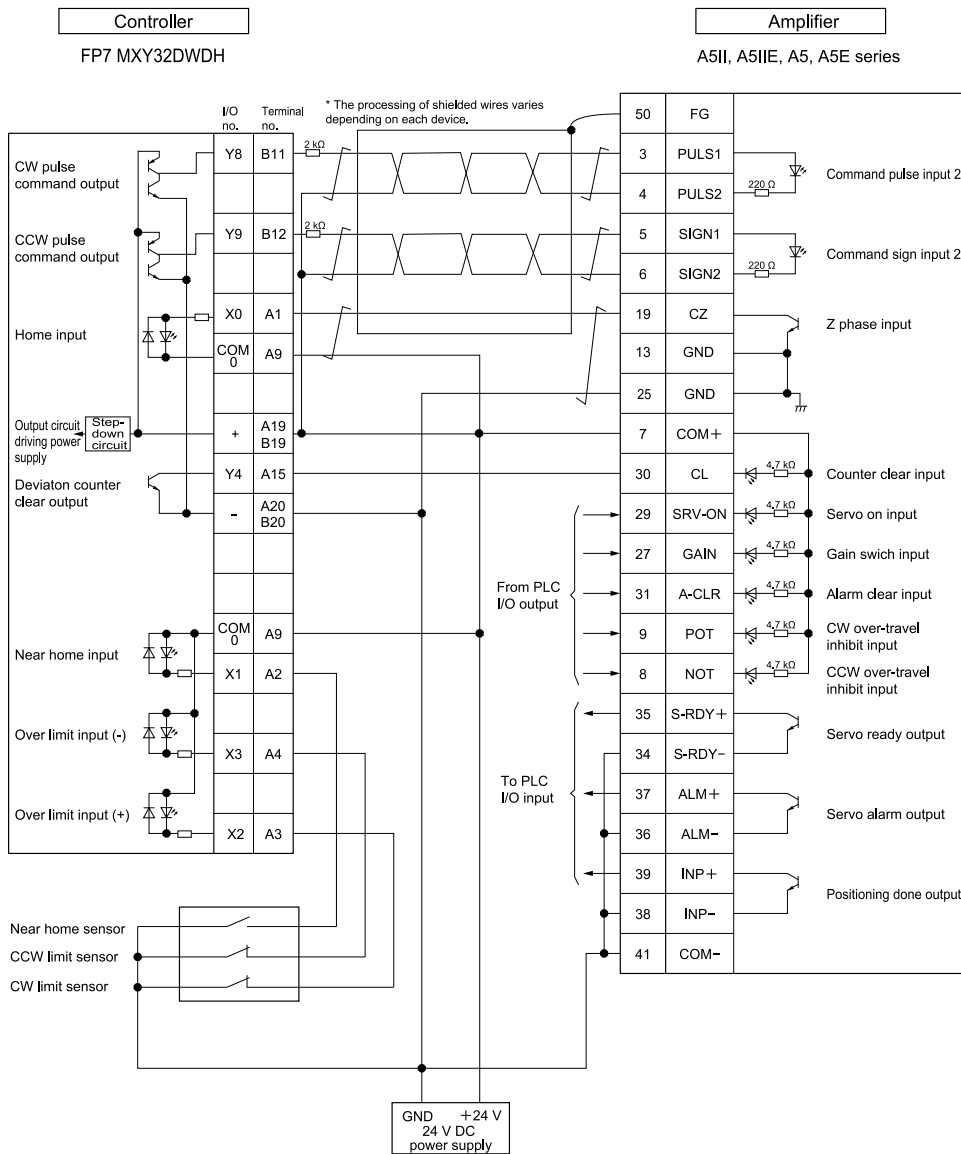

(Note 1) The allocation of I/O numbers on the controller side depends on the unit settings.

10.2 Wiring

■ Connection example using differential output

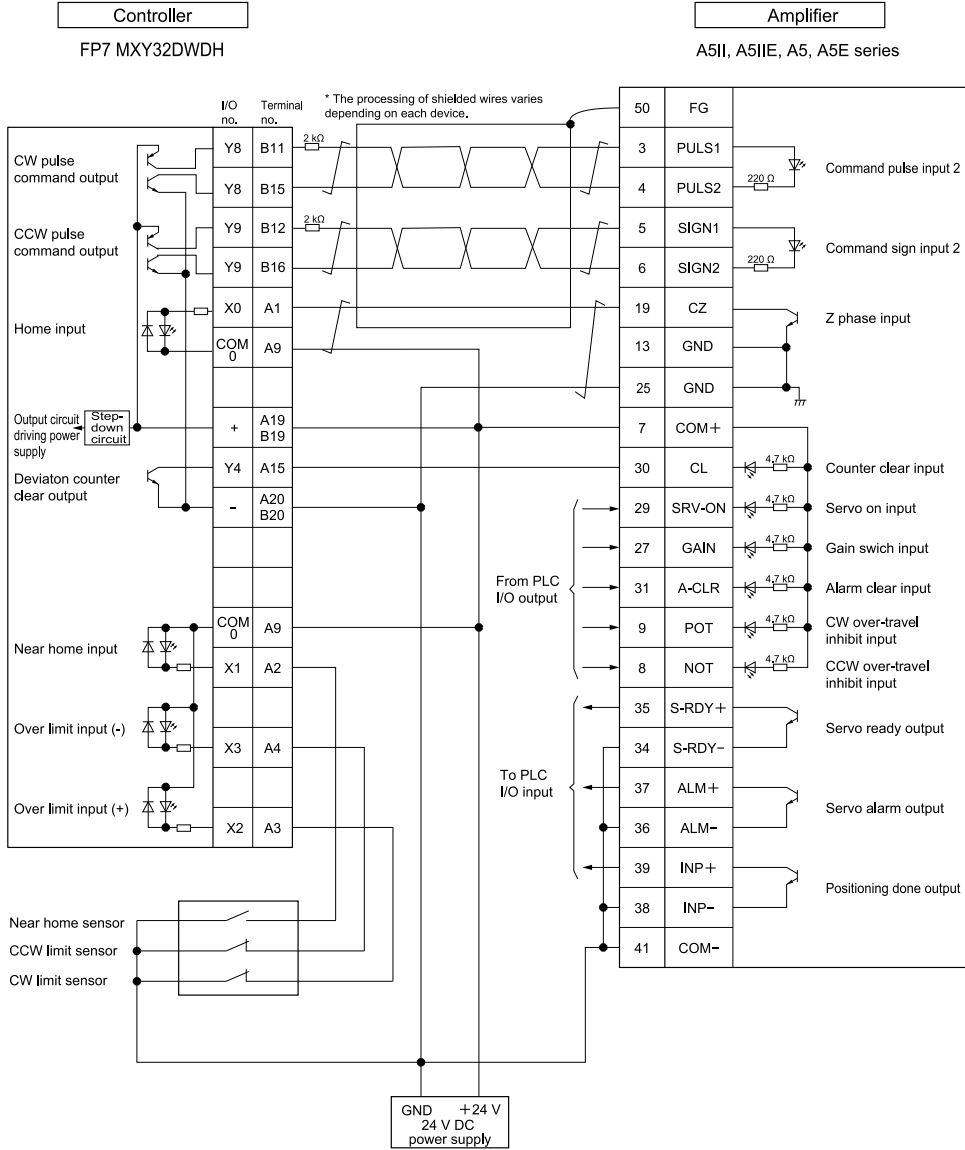

(Note 1) The allocation of I/O numbers on the controller side depends on the unit settings.

i Info.

- For details on the differential output setting method, refer to "5.2.3 Application to Differential Output".

10.2.2 Connections with Servo Motor Amplifier

■ Connections of each signal and precautions

Signal type	Point
Pulse command output	<ul style="list-style-type: none"> Connect the output allocated to each channel and the command pulse input of servo amplifier. Connect a resistor (2 kΩ) for limiting currents. Use twisted-pair cables for the connection.
Home input	<ul style="list-style-type: none"> Connect the input allocated to each channel and the Z phase input of servo amplifier. Use twisted-pair cables for the connection.
Near home input	<ul style="list-style-type: none"> Connect the near home sensor.
CCW over limit input	<ul style="list-style-type: none"> Connect the over limit switches.
CW over limit input	
Deviation counter clear output	<ul style="list-style-type: none"> Connect the output allocated to each channel and the counter clear input of servo amplifier. The length of a deviation counter clear signal is specified in the range of 1 to 100 ms in the "Parameter Setting" dialog box of Configurator PMX.
Servo on output	<ul style="list-style-type: none"> Connect an arbitrary output of PLC to the servo on input of servo amplifier.

Info.

- Use twisted-pair cables for the connection between the unit and servo amplifiers.
- Connect each signal to the terminal numbers allocated in the "Positioning" I/O terminal allocation screen in "Multi I/O Unit Setting" for FPWIN GR7.
- Terminal numbers and I/O numbers allocated to each signal vary according to the settings. Each setting is configured in the "Multi I/O Unit Setting" dialog box of FPWIN GR7. Refer to "10.4 Setting of Positioning Function".

10.2.3 Connection with Stepping Motor Driver

■ Connections of each signal and precautions

Signal type	Point
Pulse command output	<ul style="list-style-type: none"> Connect the output allocated to each channel and the command pulse input of motor driver. Use twisted-pair cables for the connection. Use a 24 VDC input for the input on the driver side. When the input interface of the driver is 5 VDC input, insert a resistor for limiting currents externally.
Home input	<ul style="list-style-type: none"> Connect the input allocated to each channel and the home sensor. Use twisted-pair cables for the connection.
Near home input	<ul style="list-style-type: none"> Connect the near home sensor.
CCW over limit input	<ul style="list-style-type: none"> Connect the over limit switches.
CW over limit input	

Info.

- Use twisted-pair cables for the connection between the unit and motor driver.
- Connect each signal to the terminal numbers allocated in the "Positioning" I/O terminal allocation screen in "Multi I/O Unit Setting" for FPWIN GR7.
- Terminal numbers and I/O numbers allocated to each signal vary according to the settings. Each setting is configured in the "Multi I/O Unit Setting" dialog box of FPWIN GR7. Refer to ["10.4 Setting of Positioning Function"](#).

10.3 Initial Operation Check

10.3.1 Safety Circuit Design

■ **System configuration example**

Installation of the over limit switch

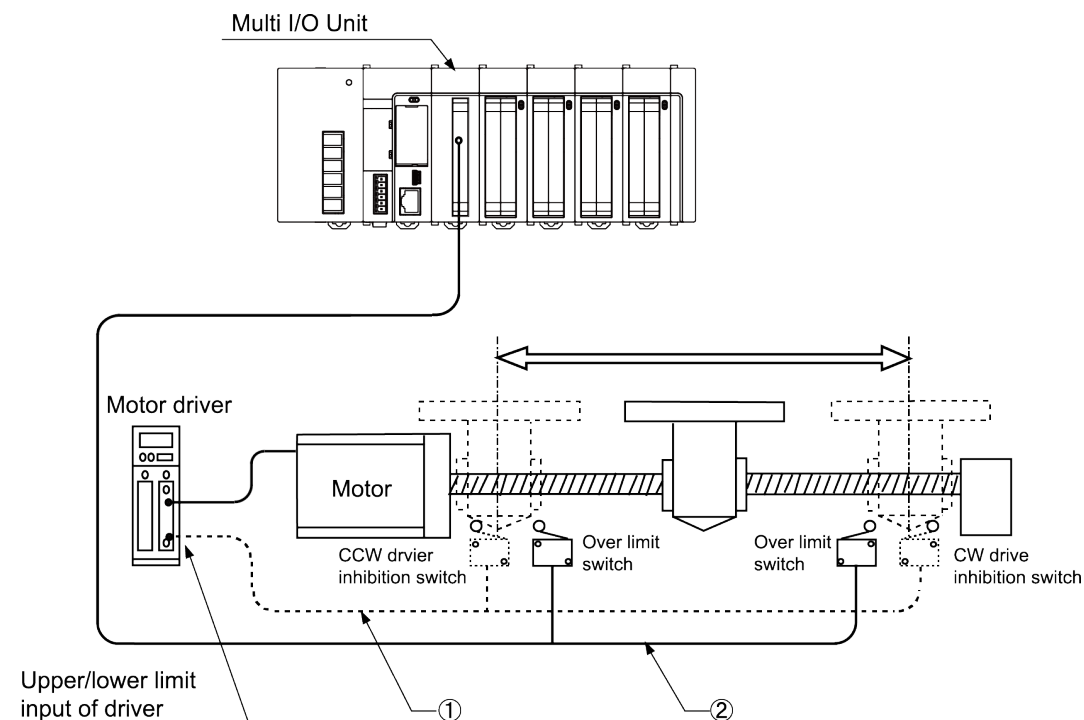

■ **Items to check the safety circuit**

No.	Item	Description
(1)	Safety circuit based on external circuit	Install the safety circuit recommended by the manufacturer of the motor being used.
(2)	Safety circuit based on the unit	Install over limit switches as shown above. Connect the over limit switches on the (+) and (-) sides to the input circuit of PLC.

10.3 Initial Operation Check

10.3.2 Before Turning On the Power

■ System configuration example

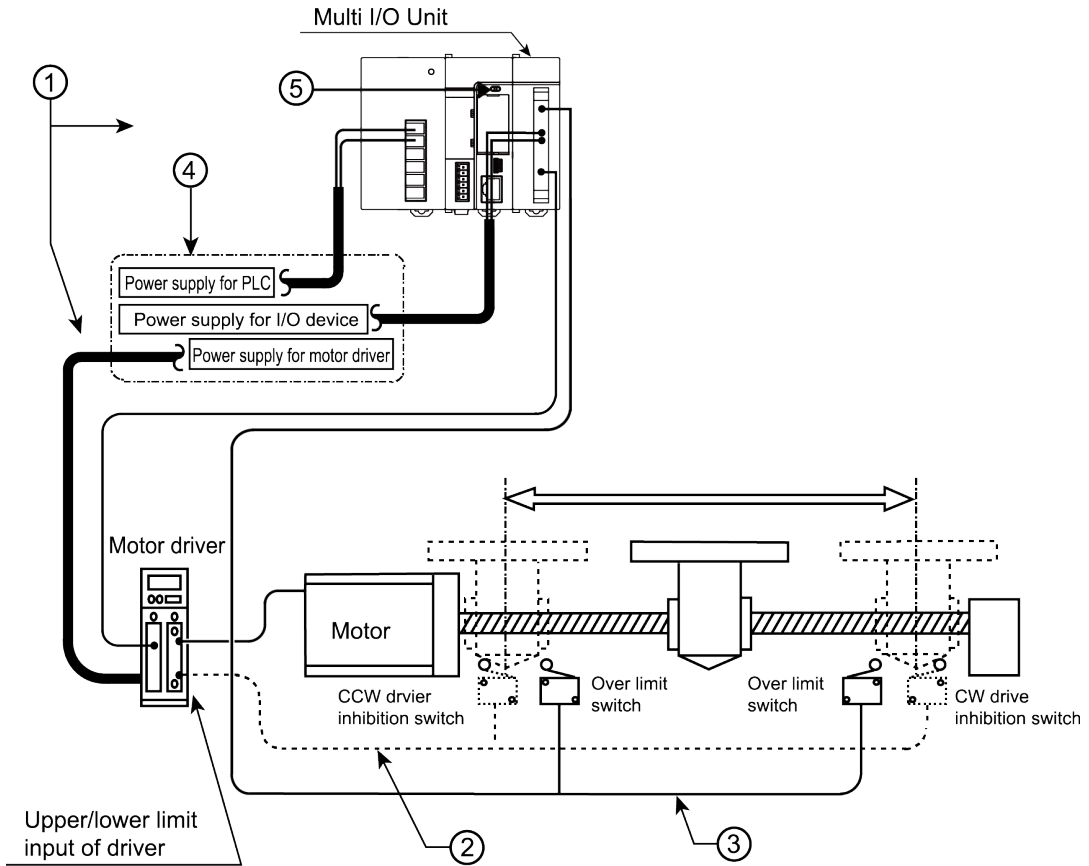

■ Items to check before turning on the power

No.	Item	Description
(1)	Checking connections to the various devices	Check to make sure the various devices have been connected as indicated by the design.
(2)	Checking the installation of the external safety circuit	Check to make sure the safety circuit (wiring and installation of over limit switch) based on an external circuit has been installed securely.
(3)	Checking the installation of the safety circuit based on the unit	Check the connection between the unit and over limit switches. Check the installation condition of the over limit switches.
(4)	Checking the procedure settings for turning on the power supplies	Make sure settings have been entered so that power supplies will be turned on in the sequence given in "Sequence for Turning On the Power".
(5)	Checking the CPU mode selection switch	Set the CPU unit to PROG. mode. The CPU unit in RUN mode may operate unexpectedly.

10.3.3 Power-on and Power-off Sequences

■ **Power-on sequence**

When turning on the power to the system incorporating the unit, consider the nature and states of any external devices connected to the system, and take sufficient care so that turning on the power will not initiate unexpected movements.

1. Turn on the power supplies for the input and output devices connected to the PLC.
2. Turn on the power supply for the PLC.
3. Turn on the power supply for the motor driver.

■ **Power-off sequence**

1. Check to make sure the rotation of the motor has stopped, and then turn off the power supply for the motor driver.
2. Turn off the power supply for the PLC.
3. Turn off the power supplies for the input and output devices connected to the PLC.

10.3.4 After Turning On the Power

■ **System configuration example**

Check each item in the following four major steps.

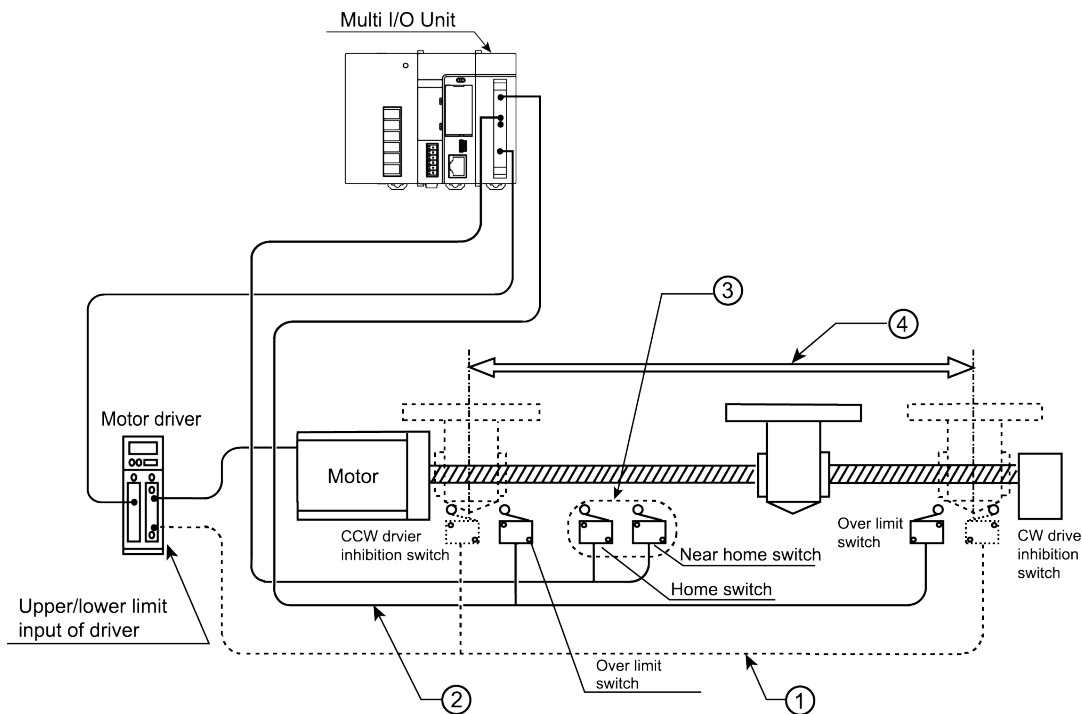

10.3 Initial Operation Check

■ Items to check after turning on the power

No.	Item	Description
(1)	Checking the installation of the external safety circuit	Check to make sure the safety circuit (wiring and installation of over limit switch) based on an external circuit has been installed securely.
(2)	Checking the safety circuit by the PLC unit	Check the connection between the unit and over limit switches. Check the installation condition of the over limit switches.
(3)	Checking the near home input and home input	Check if the near home input and home are loaded as the inputs of the PLC and activated properly by performing JOG operation or home return operation.
(4)	Checking the rotation, moving direction, and moving distance.	Check the rotation, moving direction and moving distance by performing JOG operation or positioning operation.

10.4 Setting of Positioning Function

10.4.1 I/O Allocation of Positioning Function

■ Input (External terminals)

Signal name	Application	I/O number							
		Axis 1		Axis 2		Axis 3		Axis 4	
		CH0		CH1		CH2		CH3	
		Terminal number	I/O no.	Terminal number	I/O no.	Terminal number	I/O no.	Terminal number	I/O no.
Z	Home input	A1	X0	A5	X4	B1	X8	B5	XC
DOG ^(Note 1)	Near home input	A2	X1	A6	X5	B2	X9	B6	XD
JPOS ^(Note 1)	J point control positioning start input					-	-	-	-
LMT+	Limit + input	A3	X2	A7	X6	B3	XA	B7	XE
LMT-	Limit - input	A4	X3	A8	X7	B4	XB	B8	XF

(Note 1) For channel 0 (CH0) and channel 1 (CH1), select either ""DOG"" or ""JPOS"". They can be allocated in the ""Multi I/O Unit Setting"" dialog box of FPWIN GR7. Also, for using the both inputs, connect either input to another external input terminal. They can be allocated to the unit internal I/O (JPOS/DOG) in the table below using a user program.

■ Input (Internal I/O)

Signal name	Application	I/O number							
		Axis 1		Axis 2		Axis 3		Axis 4	
		CH0		CH1		CH2		CH3	
BUSY	Control flag	(X30)		(X31)		(X32)		(X33)	
FIN	Operation done	(X34)		(X35)		(X36)		(X37)	
HFIN	Home return done	(X38)		(X39)		(X3A)		(X3B)	

■ Output (External terminals)

Signal name	Application	I/O number							
		Axis 1		Axis 2		Axis 3		Axis 4	
		CH0		CH1		CH2		CH3	
		Terminal number	I/O no.	Terminal number	I/O no.	Terminal number	I/O no.	Terminal number	I/O no.
CLR	Deviation counter clear	A15	Y4	A16	Y5	A17	Y6	A18	Y7
PLS A	Pulse output CW or Pulse output	A19	Y8	A21	YA	A23	YC	A14	YE

10.4 Setting of Positioning Function

Signal name	Application	I/O number							
		Axis 1		Axis 2		Axis 3		Axis 4	
		CH0		CH1		CH2		CH3	
		Terminal number	I/O no.	Terminal number	I/O no.	Terminal number	I/O no.	Terminal number	I/O no.
PLS B	Pulse output CCW or Sign output	A20	Y9	A22	YB	A24	YD	A14	YF

■ Output (Internal I/O)

Signal name	Application	I/O number			
		Axis 1	Axis 2	Axis 3	Axis 4
		CH0	CH1	CH2	CH3
POS	Positioning table start	(Y30)	(Y31)	(Y32)	(Y33)
MPOS	Positioning simultaneous start	(Y34)			
HOME	Home return start	(Y38)	(Y39)	(Y3A)	(Y3B)
JOG+	JOG operation start (Forward)	(Y3C)	(Y3D)	(Y3E)	(Y3F)
JOG-	JOG operation start (Reverse)	(Y40)	(Y41)	(Y42)	(Y43)
SYS STP	System stop	(Y44)			
EMG STP	Emergency stop	(Y48)	(Y49)	(Y4A)	(Y4B)
DEC STP	Deceleration stop	(Y4C)	(Y4D)	(Y4E)	(Y4F)
JPOS ^(Note 1)	J point positioning start input	(Y50)	(Y51)	-	-
DOG ^(Note 2)	Near home input	(Y52)	(Y53)	-	-
JPOS SP	J point control speed change	(Y54)	(Y55)	-	-
ECLR	Error clear	(Y56)			

(Note 1) Even when ""JPOS"" is selected for the external input X1 (or X5), Y50 (or Y51) can be used.

(Note 2) When ""DOG"" is selected for the external input X1 (or X5), Y52 (or Y53) cannot be used.

10.4.2 Configuration Using Tool Software

The setting of the positioning function is specified in the configuration menu of FPWIN GR7.

■ Setting method

The following procedure describes the process when the Multi I/O Unit (H type) has been already allocated in the I/O map.

1 2 Procedure

1. Select **Options>Multi I/O Unit Setting** in the menu bar.
The ""Select Multi I/O Unit"" dialog box is displayed.
Go to "Step 2"

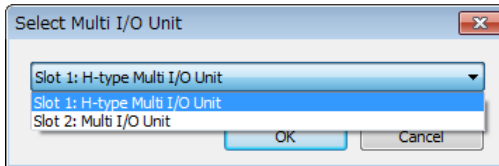

2. Select ""H-type Multi I/O Unit"", and press the [[OK]] button.
The ""Multi I/O Unit Setting"" dialog box is displayed.

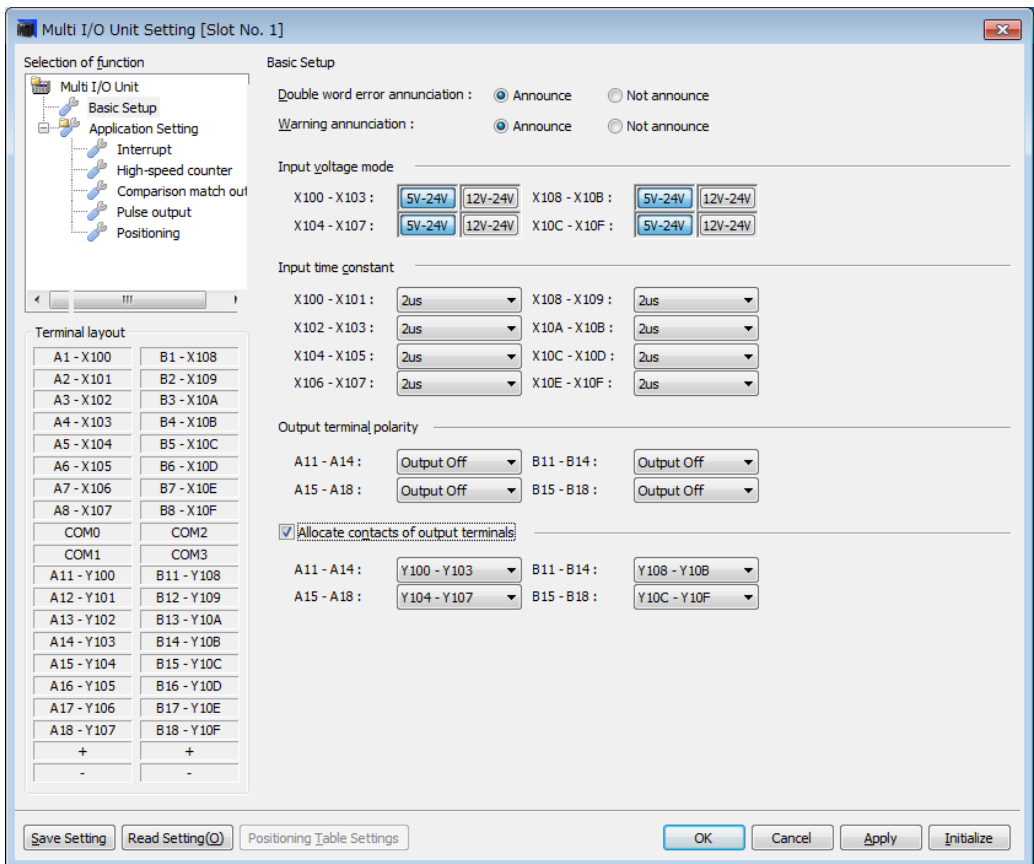

3. From the function selection tree, click ""Positioning"", and double-click an input number (or output number) to which the positioning function is allocated.
The ""Positioning Advanced"" dialog box is displayed.
Go to "Step 4"

10.4 Setting of Positioning Function

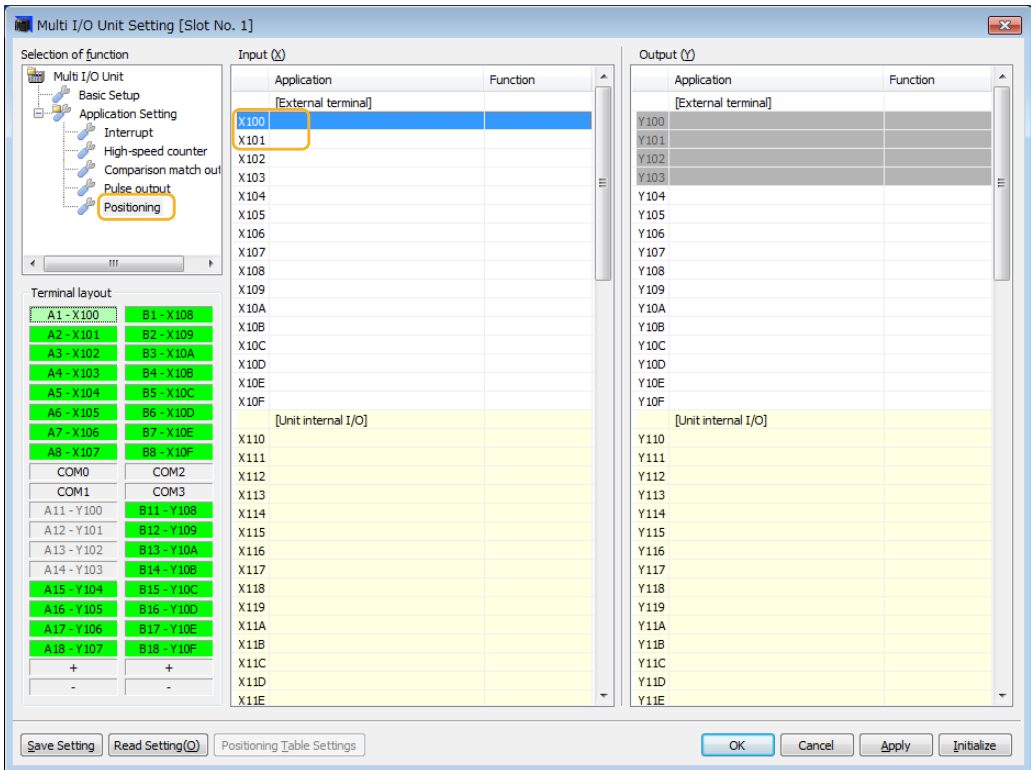

4. Select a function setting and press the [[OK]] button.

The input and output of the positioning function will be allocated. A maximum of four channels can be allocated. Allocated channel numbers are fixed.

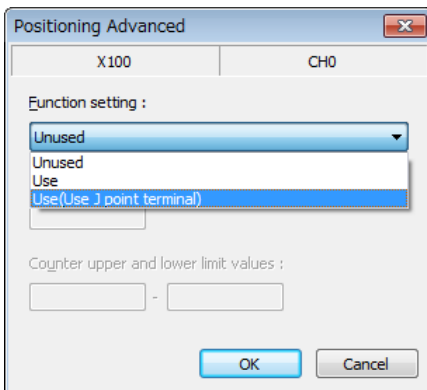

Function setting	Content
Not used	The positioning function is not allocated.
Used	The input and output of the positioning function including near home input are allocated.
Used (Use J-point terminal) (Only CH0/CH1)	The input and output of the positioning function including J point control positioning start input are allocated.

5. Set "Counter elapsed value" and "Counter upper and lower limit values" as necessary.
6. Press the [[OK]] button.

In the following example, the positioning function for two channels (CH0 and CH1) are allocated to the Multi I/O Unit (H type). The control inputs of CH0 are allocated to the inputs (X100-X103) of the internal I/O and the control inputs of CH1 are allocated to the inputs (X104-X107) automatically. Also, the control outputs of CH0 are allocated to the outputs (Y104, Y108, Y109) and the control outputs of CH1 are allocated to the outputs (Y105, Y10A, Y10B) automatically.

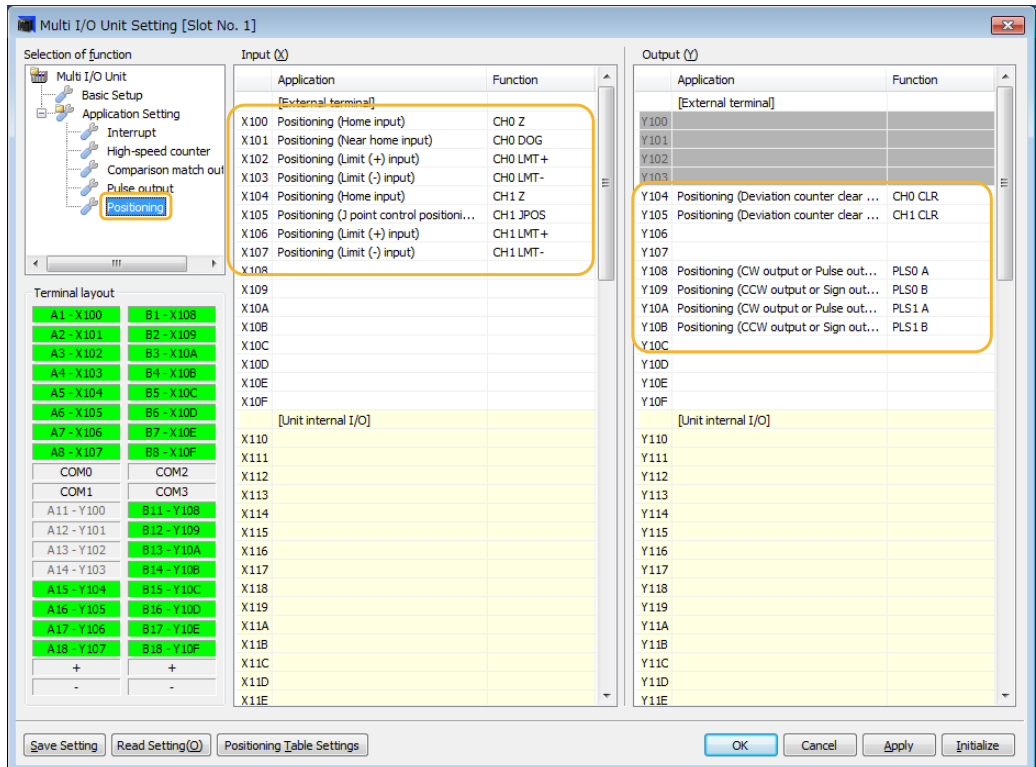

The set values will be effective when they are downloaded to the PLC with programs or other configuration information as a project.

10.5 Positioning Table Settings (Configurator PMX)

10.5 Positioning Table Settings (Configurator PMX)

10.5.1 Used Channel Setting

The following procedure describes the process when the Multi I/O Unit (H type) has been already allocated in the I/O map and the positioning function has been allocated in the "Multi I/O Unit Setting" dialog box.

1.2 Procedure

1. Press the [[Positioning Table Settings]] button in the "Multi I/O Unit Setting" dialog box.

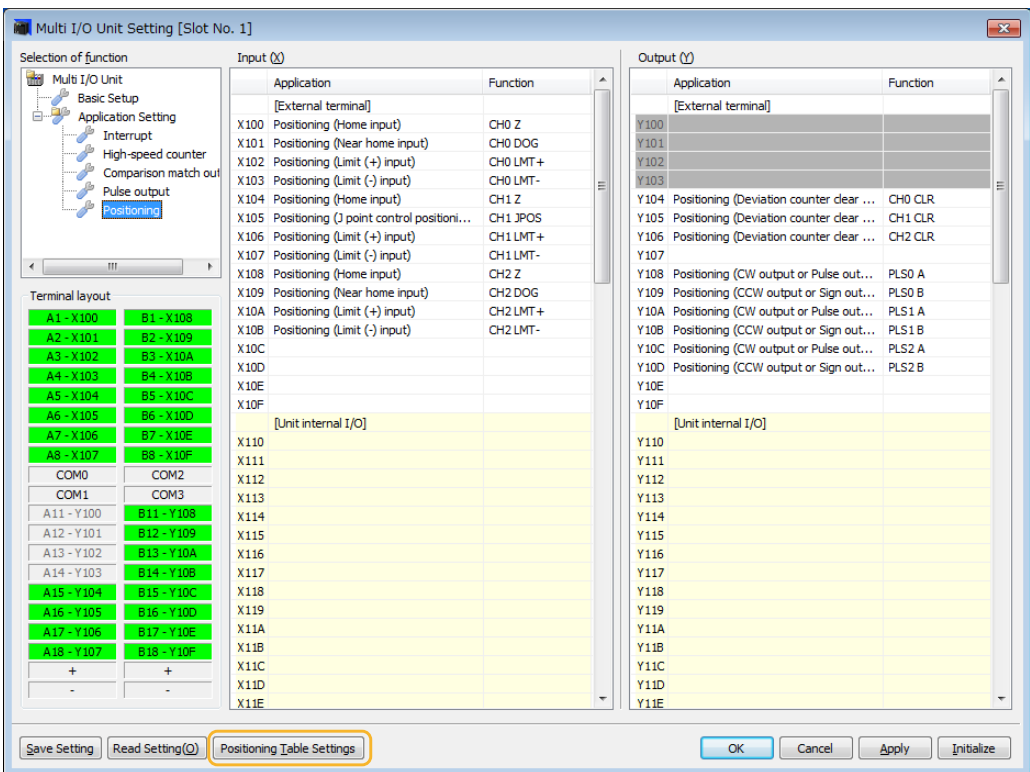

"Configurator PMX" will be activated.

10.5 Positioning Table Settings (Configurator PMX)

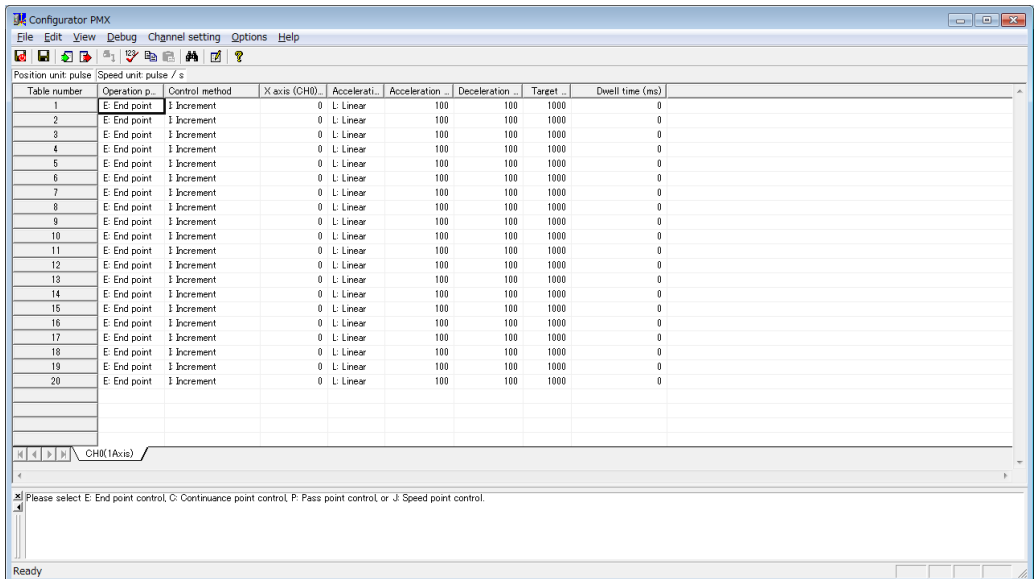

2. Select **Channel setting>Used channel setting** from the menu bar. The ""Used channel setting"" dialog box is displayed.

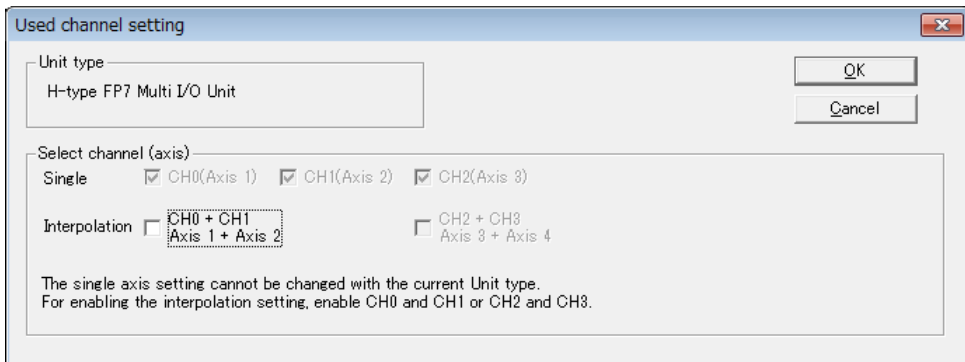

3. Select the control method for the used axes, and press the [[OK]] button. In the initial condition, the allocated channel numbers are selected for single control. To select interpolation control, check the box of "Interpolation". When the setting is changed, a confirmation message box will be displayed. Press the [[Yes]] button. The changed setting will be reflected on the setting screen.

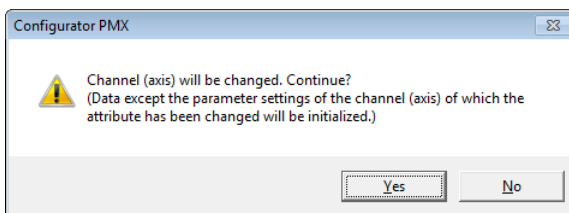

10.5 Positioning Table Settings (Configurator PMX)

i Info.

- When interpolation control is selected, the data table is changed to the channel numbers for the X and Y axes, and ["Interpolation"] is displayed on the tab.

17	E: End point	0: Linear (composit...	I: Increment
18	E: End point	0: Linear (composit...	I: Increment
 [Interpolation]CH0,CH1(1,2Axis) / CH2(3Axis)			

10.5.2 Parameter Settings

Use the Configurator PMX to allocate the most fundamental parameters for positioning control, such as the motor rotation direction, pulse output method (CW/CCW and Pulse/Sign), home input, limit input logic, and positioning control. The following procedure is explained on the condition that the Configurator PMX has already started.

For the procedure of activating Configurator PMX, refer to ""10.5.1 Used Channel Setting"".

■ Parameters

Parameter name		Default (Unit)	Settings
Basic Setup	Pulse output method	Pulse/Sign	Pulse/Sign, CW/CCW
	Pulse output rotation direction	CW direction +	When selecting Pulse/Sign mode: CW direction +: Select this setting for the case that the elapsed value is plused when Sign output turns off. CCW direction +: Select this setting for the case that the elapsed value is plused when Sign output turns on.
			When selecting CW/CCW mode: CW direction +: Select this setting for the case that the elapsed value is plused at the time of CW output. CCW direction +: Select this setting for the case that the elapsed value is plused at the time of CCW output.
	Startup Speed	100 (pps)	Set the startup speed common to each operation. This setting is common to JOG operation, home return, E-point control, P-point control, C-point control and J-point control. Setting range: 1 to 500,000
Positioning repeat count	0	Specify this setting for performing repetitive controls when using E-point/P-point/C-point control. 0, 1: Not repeat 2 to 254: Repeat for the specified number of times. 255: Repeat infinitely until the execution of stop control.	
Input setting	Home position logic	Normal Open	Select the input logic for each switch. Normal Open, Normal Close
	Near home input logic	Normal Open	
	Limit + switch logic	Normal Open	
	Limit - switch logic	Normal Open	

10.5 Positioning Table Settings (Configurator PMX)

Parameter name		Default (Unit)	Settings
Positioning setting	Starting table number	1	Specify the table number to be started when a positioning start signal is input. Setting value: 1 to 20
	Simultaneous starting table number	0	Specify the table number to be started when a positioning simultaneous start signal is input. Setting value: 0 Specified channels do not start simultaneously. Setting value: 1 to 20 Specified channels start with the set table number.
Home return	Home return method	Not use	DOG method 1, DOG method 2, DOG method 3, Home position method, Data set method, Not use
	Home return direction	Limit (-) direction	Limit (-) direction, Limit (+) direction
	Home return acceleration time	100 (ms)	Setting range: 1 to 10,000
	Home return deceleration time	100 (ms)	Setting range: 1 to 10,000
	Home return target speed	1000 (pps)	Setting range: 1 to 500,000
	Home return creep speed	100 (pps)	Setting range: 1 to 500,000
	Deviation counter clear time	1 (ms)	Setting range: 0 to 100 For 0, no deviation counter clear signal is output.
	Coordinate origin	0 (Pulse)	When the home return method is Data set method, specify a coordinate origin. Setting range: -1,073,741,824 to +1,073,741,823
JOG operation setting	JOG acceleration time ^(Note 1)	0 (ms)	Setting range: 0 to 10,000
	JOG deceleration time ^(Note 1)	0 (ms)	Setting range: 0 to 10,000
	JOG target speed	1000 (pps)	Setting range: 1 to 500,000
	J point change target speed	1000 (pps)	Set this setting for changing the speed during J-point control. Setting range: 1 to 500,000
Stop setting	Emergency stop deceleration time	100 (ms)	Setting range: 1 to 10,000 ^(Note 2)
	Limit stop deceleration time	100 (ms)	Setting range: 1 to 10,000 ^(Note 2)

(Note 1) When either of them is set to 0 ms, the target speed is output without acceleration/deceleration.

(Note 2) Set a value by converting to a deceleration time from 500 kHz to 0 kHz.

1.2 Procedure

1. Select **Channel setting>Parameter settings** from the menu bar.
The "Parameter Settings" dialog box is displayed.

10.5 Positioning Table Settings (Configurator PMX)

Parameter settings		Channel0 (1 axis)	Channel1 (2 axis)	Channel2 (3 axis)
Basic	Pulse output method	Pulse/Sign	Pulse/Sign	Pulse/Sign
	Pulse output rotation direction	CW direction +	CW direction +	CW direction +
	Startup speed	100	100	100
	Positioning repeat count	0	0	0
Input	Home position logic	Normal Open	Normal Open	Normal Open
	Home position proximity logic	Normal Open	Normal Open	Normal Open
	Limit + switch logic	Normal Open	Normal Open	Normal Open
	Limit - switch logic	Normal Close	Normal Close	Normal Close
Positioning setting	Starting table number	1	1	1
	Simultaneous starting table number	0	0	0
Home return	Home return method	DOG method 1	DOG method 1	DOG method 1
	Home return direction	Limit (-) direction	Limit (-) direction	Limit (-) direction
	Home return acceleration time (ms)	100	100	100
	Home return deceleration time (ms)	100	100	100
	Home return target speed	1000	1000	1000
	Home return creep speed	100	100	100
	Deviation counter clear time (ms)	1	1	1
	Coordinate origin	0	0	0
JOG operation	JOG acceleration time (ms)	100	100	100
	JOG deceleration time (ms)	100	100	100
	JOG target speed	1000	1000	1000
	J point change target speed	1000	1000	1000

Set the output method for pulse output.
Select from the followings.
Pulse/Sign method, CW/CCW method

OK Cancel Channel copy Initialize

2. Make necessary parameter settings according to the application and press the [[OK]] button.

The settings will be stored as part of positioning parameter data.

10.5.3 Creating Positioning Data Table

- The positioning data tables are divided into sheets for each axis, and 20 tables ranging no. 1 to no. 20 can be set.

■ For independent axis control

Parameter name	Default (Unit)	Content
Operation pattern	E: End point	Select one from the following operation patterns. E: End point, C: Continuance point, P: Pass point, J: Speed point
Control method	I: Increment	Select either I: Increment or A: Absolute.

10.5 Positioning Table Settings (Configurator PMX)

Parameter name	Default (Unit)	Content							
		<table border="1"> <tr> <td>I: Increment</td> <td>The position moves relatively from the current position by a specified amount.</td> </tr> <tr> <td>A: Absolute</td> <td>The position moves to an absolute coordinate determined by home return operation.</td> </tr> </table>	I: Increment	The position moves relatively from the current position by a specified amount.	A: Absolute	The position moves to an absolute coordinate determined by home return operation.			
I: Increment	The position moves relatively from the current position by a specified amount.								
A: Absolute	The position moves to an absolute coordinate determined by home return operation.								
X-axis movement amount	0 (pulse)	Input a movement amount. Setting range: -1,073,741,824 to +1,073,741,823							
Acceleration/deceleration type	L: Linear	L: Linear (Fixed)							
Acceleration time	100 (ms)	Set an acceleration time. Setting range: 1 to 10,000							
Deceleration time	100 (ms)	Set a deceleration time. Setting range: 1 to 10,000							
Target speed	1000 (pps)	Set a target speed. Setting range: 1 to 500,000							
Dwell time	0 (ms)	<p>Set a dwell time from the end of each positioning control of positioning operation table to the next operation. Note that operations vary depending on operation patterns.</p> <table border="1"> <tr> <td>When operation pattern is E (end point)</td> <td>Turns on the positioning end contact after the elapse of the dwell time.</td> </tr> <tr> <td>When operation pattern is C (continuance point)</td> <td>Stops the motor operation for the dwell time and start the next operation.</td> </tr> <tr> <td>When operation pattern is P (pass point)</td> <td rowspan="2">This setting is ignored.</td> </tr> <tr> <td>When operation pattern is J (speed point)</td> </tr> </table> <p>Setting range: 0 to 32,767</p>	When operation pattern is E (end point)	Turns on the positioning end contact after the elapse of the dwell time.	When operation pattern is C (continuance point)	Stops the motor operation for the dwell time and start the next operation.	When operation pattern is P (pass point)	This setting is ignored.	When operation pattern is J (speed point)
When operation pattern is E (end point)	Turns on the positioning end contact after the elapse of the dwell time.								
When operation pattern is C (continuance point)	Stops the motor operation for the dwell time and start the next operation.								
When operation pattern is P (pass point)	This setting is ignored.								
When operation pattern is J (speed point)									

■ For interpolation control

Parameter name	Default (Unit)	Content				
Operation pattern	E: End point	Select one from the following operation patterns. E: End point, C: Continuance point, P: Pass point				
Interpolation operation	Linear (Composite speed)	Select a specification method of speed. Linear (Composite speed): Specify the speed combining the speed of X and Y axes. Linear (Long axis speed): Specify the speed on the long axis side whose movement amount is large.				
Control method	I: Increment	<p>Select either I: Increment or A: Absolute.</p> <table border="1"> <tr> <td>I: Increment</td> <td>The position moves relatively from the current position by a specified amount.</td> </tr> <tr> <td>A: Absolute</td> <td>The position moves to an absolute coordinate determined by home return operation.</td> </tr> </table>	I: Increment	The position moves relatively from the current position by a specified amount.	A: Absolute	The position moves to an absolute coordinate determined by home return operation.
I: Increment	The position moves relatively from the current position by a specified amount.					
A: Absolute	The position moves to an absolute coordinate determined by home return operation.					

10.5 Positioning Table Settings (Configurator PMX)

Parameter name	Default (Unit)	Content	
X-axis movement amount	0 (pulse)	Input a movement amount of the channel specified for X axis. Setting range: -8,388,608 to +8,388,607	
Y-axis movement amount	0 (pulse)	Input a movement amount of the channel specified for Y axis. Setting range: -8,388,608 to +8,388,607	
Acceleration/deceleration type	L: Linear	L: Linear (Fixed)	
Acceleration time	100 (ms)	Set an acceleration time. Setting range: 1 to 10,000	
Deceleration time	100 (ms)	Set a deceleration time. Setting range: 1 to 10,000	
Interpolation speed	1000 (pps)	Set either composite speed or major axis speed in accordance with the selection of interpolation operation. Setting range: 1 to 500,000	
Dwell time	0 (ms)	Set a dwell time from the end of each positioning control of positioning operation table to the next operation. Note that operations vary depending on operation patterns.	
		When operation pattern is E (end point)	Turns on the positioning end contact after the elapse of the dwell time.
		When operation pattern is C (continuance point)	Stops the motor operation for the dwell time and start the next operation.
		When operation pattern is P (pass point)	This setting is ignored.
Setting range: 0 to 32,767			

■ Selection of positioning operation patterns

- For the E-point control, input settings in one row.
- For P-point control (speed change control), C-point control (continuance point control) and J-point control (JOG positioning control), they should be combined with E-point control of the next step as a pair and the settings should be input in two rows.

The screenshot shows the 'Configurator PMX' window with a menu bar (File, Edit, View, Debug, Channel setting, Options, Help) and a toolbar. Below the toolbar, it displays 'Position unit: pulse' and 'Speed unit: pulse / s'. The main area contains a table with the following data:

Table number	Operation pattern	Control method	X axis (GH0)	Accelerati...	Acceleration ...	Deceleration ...	Target ...	Dwell time (ms)
1	E: End point	Increment	100000	L: Linear	100	200	20000	50
2	P: Pass point	Increment	5000	L: Linear	100	200	20000	0
3	E: End point	Increment	100000	L: Linear	150	250	10000	50
4	C: Continuance point	Increment	100000	L: Linear	100	200	20000	30
5	E: End point	Increment	5000	L: Linear	150	250	10000	50
6	J: Speed point	Increment	0	L: Linear	100	200	20000	30
7	E: End point	Increment	100000	L: Linear	150	250	10000	50

■ Table numbers and activation of positioning

- Table numbers on the Configurator PMX are specified in user programs.

10.5 Positioning Table Settings (Configurator PMX)

- The unit executes the control under the conditions set in the table by turning on the positioning start contact corresponding to a desired channel number (axis number) and table number. Specify the first data table number for each control in the program.

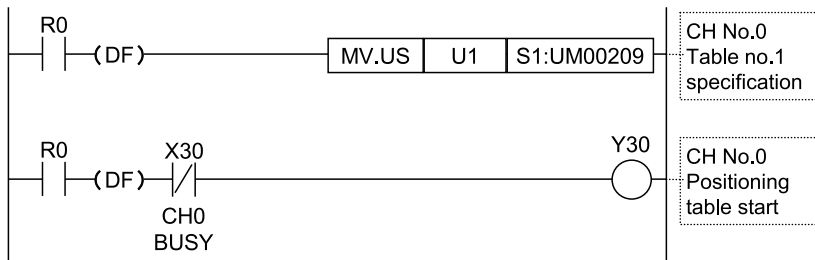

Info.

- For details of each control, refer to ""10.10 Positioning Control"".

10.5.4 Saving Positioning Parameters

Information on positioning parameters and positioning data tables set on Configurator PMX is saved as part of program files.

1 2 Procedure

1. Select **File>Save changes and exit** from the menu bar.
A confirmation message box appears.

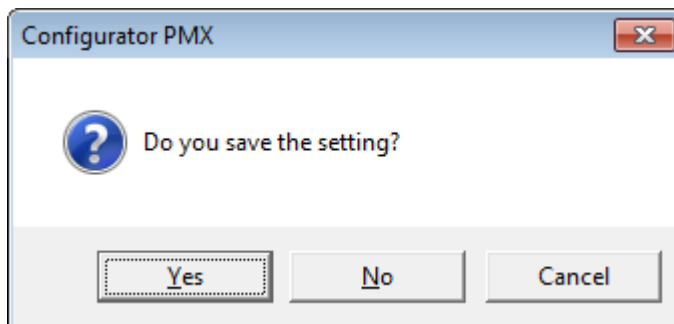

2. Press [Yes].
 - The set information will be saved as part of project files.
 - When selecting [No], the changes made immediately before will be discarded. When selecting [Cancel], it will return to the setting screen of Configurator PMX with the changes made immediately before still in place.

10.5 Positioning Table Settings (Configurator PMX)

10.5.5 Export and Import

- Basic parameters and positioning parameters set can be exported to and imported from the Configurator PMX.
- Information on positioning parameters and positioning tables saved by using the export function can be reused between projects.

1 2 Procedure

1. Select **File>Export** from the menu bar.
The saving destination and file names appear.
2. Enter a saving destination and file name, and press [Save] button.
Information on the parameters and positioning data tables will be saved in a file with a “.pmx” extension.

i Info.

- When export is executed, information on the positioning data tables will be saved along with parameters set in the parameter setting menu.

10.5.6 Check on Parameter Data

- The following procedure is explained on the condition that the Configurator PMX has already started.

1 2 Procedure

1. Select **Debug>Check Parameter and Data Values** from the menu bar.
A message box appears to show the check result. If there is an error in the settings for the positioning data tables, an error message will appear and the cursor will move to the corresponding error position.

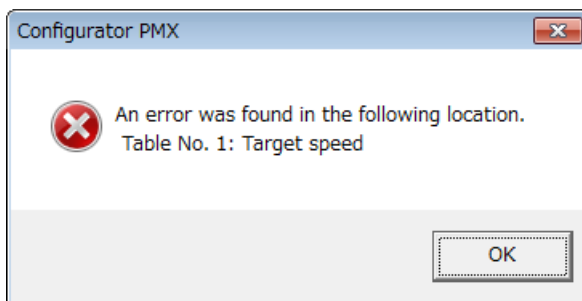

10.5.7 Writing Parameters to Unit

- Set parameter information is transferred to the CPU unit.
- The following procedure is explained on the condition that the Configurator PMX has already started.

1 2 Procedure

- 1.** Select **File>Save changes and exit** from the menu bar of Configurator PMX.
- 2.** When ""Do you want to save the setting?"" appears, press [[Yes (Y)]].
- 3.** Select **Online>Download To PLC** from the FPWIN GR7 menu bar.
Positioning data will also be downloaded to the CPU unit together with programs comment and system register information.
File>Download positioning table in the menu bar of "Configurator PMX" is not available for the Multi I/O Unit (H type).

10.6 Read/Write of Elapsed Value

10.6 Read/Write of Elapsed Value

10.6.1 Elapsed Value (Current Value) Area

- They are stored as 2-word 32-bit data in the axis information area of unit memories.
- The elapsed value area will be reset when the power supply turns off. It will be held when switching the mode from RUN to PROG.

■ Counting range of elapsed value (current value) area

Item	Range
During single axis control	-1073741824 to +1073741823
During interpolation axis control	-8388608 to +8388607

10.6.2 Reading Elapsed Value (Current Value) Area

The elapsed value can be read from the unit memory (elapsed value: current value coordinate)area.

■ Sample program

In this example, the elapsed value of the Multi I/O Unit installed in the slot 0 is read.

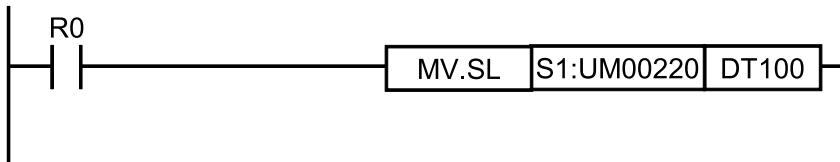

■ Allocation of unit memories (UM)

Signal name	CH0	CH1	CH2	CH3
Elapsed value (Current value coordinates)	UM00220-UM00221	UM0022A-UM0022B	UM00234-UM00235	UM0023E-UM0023F
PLS/PWM counter	UM00170-UM00171	UM00172-UM00173	UM00174-UM00175	UM00176-UM00177

(Note 1) The elapsed values of the channels which use positioning control are also applied in the ""PLS/PWM counter elapsed value area"". They can be used for the comparison match function, etc.

i Info.

- Programs for reading and writing values from unit memories can be easily created by using the ""Template Function"" of FPWIN GR7. Refer to "[11.1 Creating of Ladder Programs Using Templates](#)".

10.7 Stop Control

10.7.1 Type of stop operations

■ Type of stop operations

Name	Time chart	Occurrence condition and operation
System stop		<ul style="list-style-type: none"> Once the system stop contact (Y44) turns on, an active operation will stop and the pulse outputs of all channels will immediately stop. The similar operation is performed when the operation mode of the control unit is switched from RUN to PROG.
Emergency stop		<ul style="list-style-type: none"> Once an emergency stop contact (Y48-Y4B) turns on, an active operation will stop and the pulse outputs of corresponding channels will stop. Performs a deceleration stop in the emergency stop deceleration time specified in the positioning parameter setting menu of Configurator PMX. <p>The specified time is a deceleration time from 500 kHz.</p>
Limit stop		<ul style="list-style-type: none"> Once the limit + input or limit - input (X2, X3, X6, X7, XA, XB, XE, XF) turns on, an active operation will stop and the pulse outputs of corresponding channels will stop. Performs a deceleration stop in the limit stop deceleration time specified in the positioning parameter setting menu of Configurator PMX. <p>The specified time is a deceleration time from 500 kHz.</p>
Deceleration stop		<ul style="list-style-type: none"> Once a deceleration stop contact (Y4C-Y4F) turns on, an active operation will stop and the pulse outputs of corresponding channels will stop. Performs a deceleration stop in the deceleration time specified for the active positioning operation.

■ Execution of stop operations

Stop controls are executed when the following I/O signals turn on.

1. System stop > 2. Emergency stop > 3. Limit stop > 4. Deceleration stop

10.7 Stop Control

Allocation of I/O numbers (External inputs)

Signal name	Application	I/O number							
		Axis 1		Axis 2		Axis 3		Axis 4	
		CH0		CH1		CH2		CH3	
		External connection terminal no.	Internal input no.	External connection terminal no.	Internal input no.	External connection terminal no.	Internal input no.	External connection terminal no.	Internal input no.
LMT+	Limit + input	A3	X2	A7	X6	B3	XA	B7	XE
LMT-	Limit - input	A4	X3	A8	X7	B4	XB	B8	XF

(Note 1) The limit inputs are processed once in one scan.

Allocation of I/O numbers (Internal inputs)

Signal name	Application	I/O number			
		Axis 1	Axis 2	Axis 3	Axis 4
		CH0	CH1	CH2	CH3
SYS STP	System stop	Y44			
EMG STP	Emergency stop	Y48	Y49	Y4A	Y4B
DEC STP	Deceleration stop	Y4C	Y4D	Y4E	Y4F

Sample program

The execution condition is set to be always executed. A program is shown below for when the inputs of ""SYS STP"", ""EMG STP"" and ""DEC STP"" are allocated to the external connection terminal numbers X108, X109, and X10A.

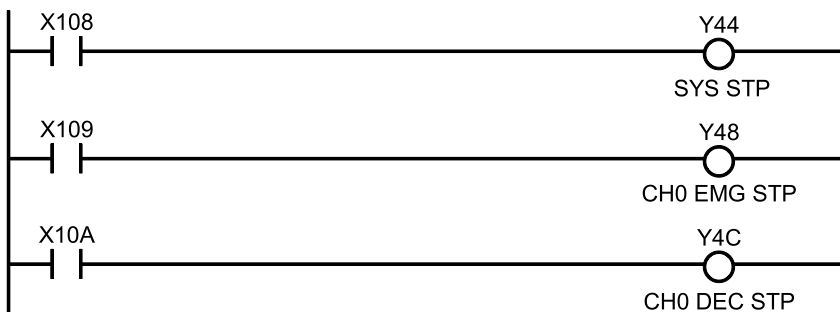

10.7.2 Characteristics of Stop Operations

Priority of stop operations

When stop control requests are made simultaneously, the stop operations are executed according to the following priority.

1. System stop > 2. Emergency stop > 3. Limit stop > 4. Deceleration stop

■ Dwell time setting

The dwell time setting is invalid in the stop operations regardless of patterns.

■ Flag processing

- In the case of system stop, the busy signal turns off and the operation done signal turns on.
- In the cases of emergency stop, limit stop and deceleration stop, the busy signal turns off and the operation done signal turns on after the completion of the pulse output during deceleration.

■ Elapsed value area (Current value coordinate)

- Even in a stop operation, the elapsed value area is always updated.
- After the emergency stop, limit stop or deceleration stop, deceleration is performed with each specified deceleration time, and the value when the pulse output stops is stored.
- In the case of system stop, the value when the pulse output stops is stored.

 Info.

- For details of the deceleration stop operations when repetitive control is executed, refer to "[10.11.3 Stop Operation During Repeat Operation](#)".

10.8 JOG operation

10.8.1 Setting and Operation of JOG Operation

An operation in which the motor is rotated only while operation commands are being input is called JOG operation. This is used to forcibly rotate the motor using input from an external switch, for instance when to make adjustments.

Pulses are output while the JOG operation start contact is on.

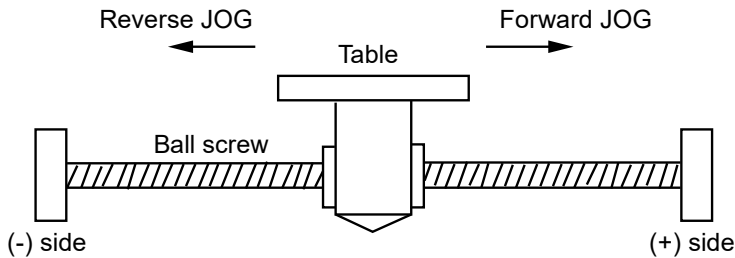

■ **Operation diagram**

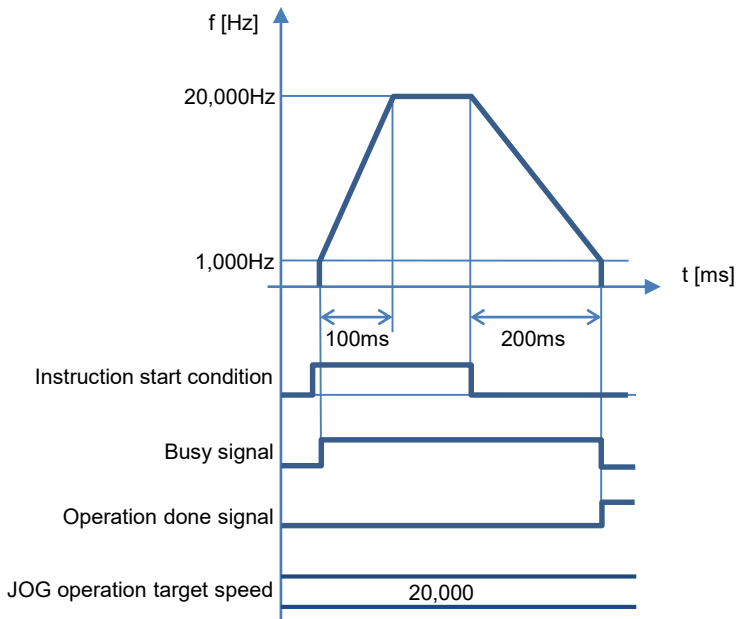

■ **Operations of each contact**

- The BUSY flags (X30-X33), which indicate that the motor is running, will turn on when the JOG operation starts, and they will turn off when the operation completes.
- The operation done flags (X34-X37), which indicate the completion of operation, will turn on when the current operation is completed, and they will be held until the next positioning control, JOG operation or home return operation starts.

■ Cautions on Programming

- The startup contact and flag numbers vary depending on channel numbers (axis numbers).
The parameters for JOG operations are specified in the "Positioning Parameter Setting" menu of Configurator PMX.

■ Settings

Item	Value	
Axis Setting Area	Startup Speed	1,000 Hz
	JOG acceleration time	100 ms
	JOG deceleration time	200 ms
	JOG target speed	20,000 Hz

■ Configurator PMX settings

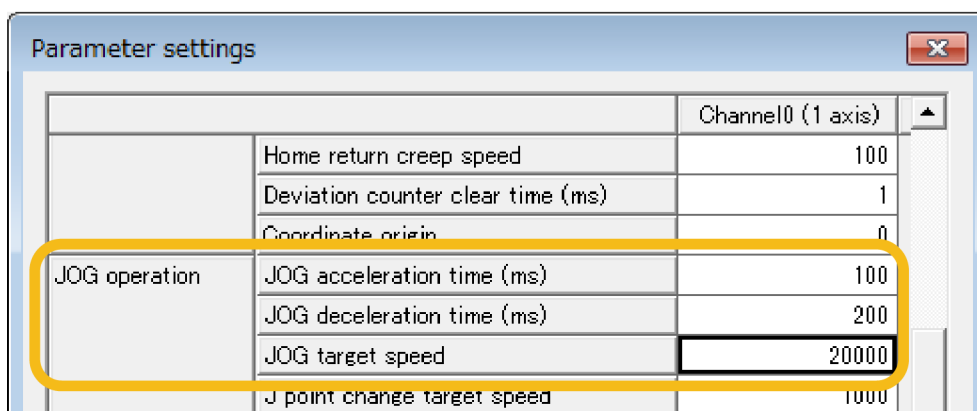

■ Allocation of I/O signals

Signal name	Application	I/O number			
		Axis 1	Axis 2	Axis 3	Axis 4
		CH0	CH1	CH2	CH3
JOG+	JOG operation start (Forward)	Y3C	Y3D	Y3E	Y3F
JOG-	JOG operation start (Reverse)	Y40	Y41	Y42	Y43

■ Sample program

The execution condition is set to be always executed.

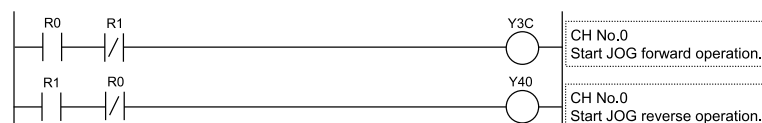

10.8 JOG operation

■ Operation at limit input

Condition	Direction	Limit status	Operation
At startup	Forward	Over limit input (+): ON	Not executable, Error occurs.
		Over limit input (-): ON	Executable
	Reverse	Over limit input (+): ON	Executable
		Over limit input (-): ON	Not executable, Error occurs.
During operation	Forward	Over limit input (+): ON	Limit stops, error occurs ^(Note 1)
		Over limit input (-): ON	Limit stops, error occurs ^(Note 1)
	Reverse	Over limit input (+): ON	Limit stops, error occurs ^(Note 1)
		Over limit input (-): ON	Limit stops, error occurs ^(Note 1)

(Note 1) Create a program as below if you do not want to restart the instruction when the limit error occurs during an operation when the execution condition has been set to be always executed.

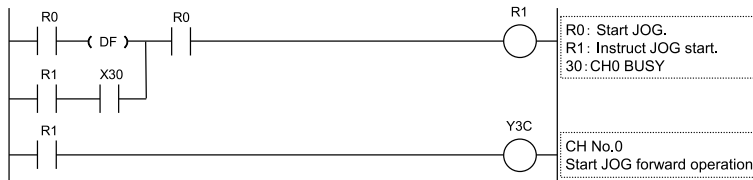

10.8.2 Setting and Operation of JOG Operation (Speed Changes)

It is possible to change a target speed during the JOG operation. The target speed is changed by rewriting unit memories using a user program.

■ Operation diagram

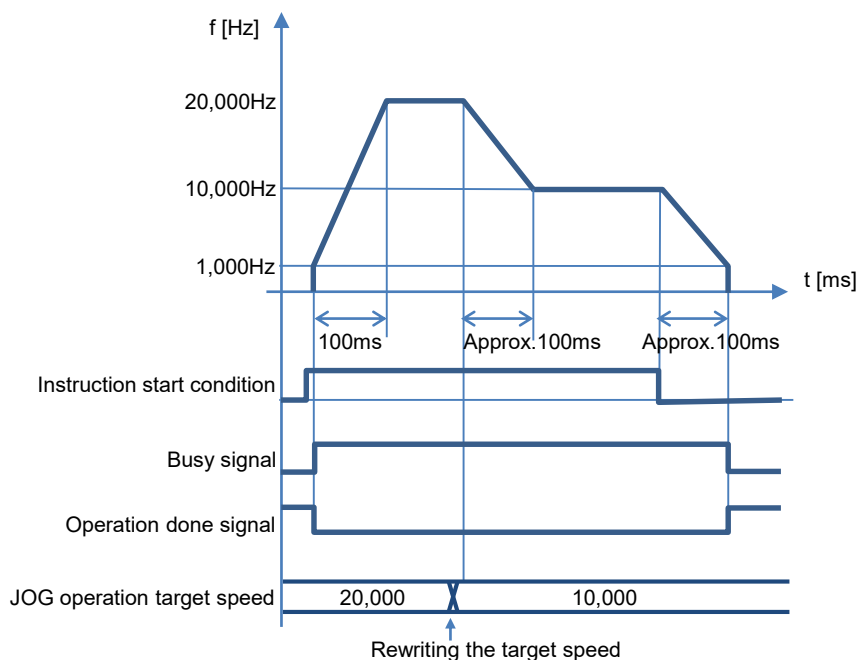

■ Operations of each contact

- The BUSY flags (X30-X33), which indicate that the motor is running, will turn on when the JOG operation starts, and they will turn off when the operation completes.
- The operation done flags (X34-X37), which indicate the completion of operation, will turn on when the current operation is completed, and they will be held until the next positioning control, JOG operation or home return operation starts.

■ Characteristics of acceleration/deceleration zone when changing speeds

- The speeds of acceleration zone and deceleration zone changes by approx. 100 us when changing the speeds in the JOG operation. The speed variation is obtained by the following formula.

Speed variation = (JOG operation target speed - Startup speed) / (JOG acceleration time or JOG deceleration time)

- When the JOG acceleration time or JOG deceleration time is set to 0 ms, the speed will be changed immediately.

■ Settings

Item	Setting example	
Axis Setting Area	Startup Speed	1,000 Hz
	JOG acceleration time	100 ms
	JOG deceleration time	200 ms

10.8 JOG operation

Item	Setting example
JOG operation target speed	20,000 Hz -> 10,000 Hz

■ Configurator PMX settings

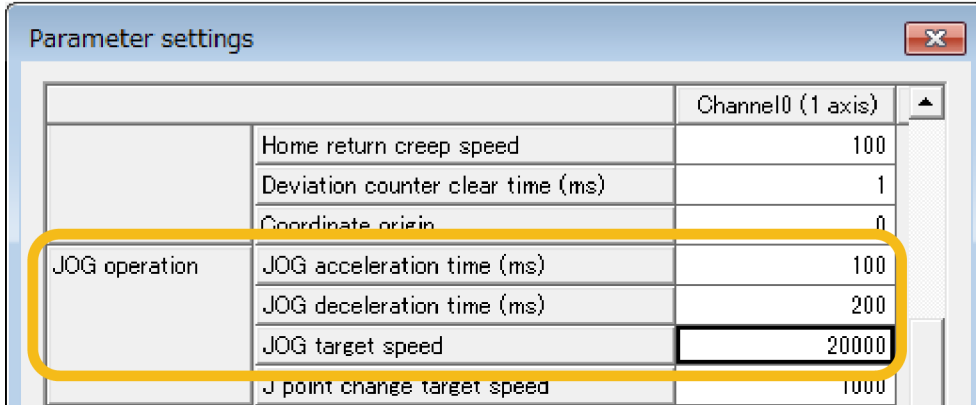

■ Allocation of I/O signals

Signal name	Application	I/O number			
		Axis 1	Axis 2	Axis 3	Axis 4
		CH0	CH1	CH2	CH3
JOG+	JOG operation start (Forward)	Y3C	Y3D	Y3E	Y3F
JOG-	JOG operation start (Reverse)	Y40	Y41	Y42	Y43

■ Sample program

The execution condition is set to be always executed.

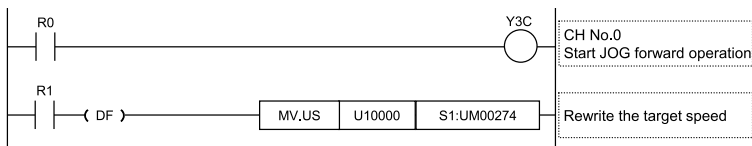

■ Cautions on Programming

- To change a speed during the JOG operation, rewrite the value of the unit memory (axis setting area) using a user program.
- The startup contact and flag numbers vary depending on channel numbers (axis numbers).

10.8.3 Speed Changes in JOG Operation

- The value of ""JOG operation target speed"" in the axis setting area is constantly monitored while the operation is being executed. When the target speed is changed, it will be changed with the same acceleration.
- The speed change is executed after the completion of acceleration/deceleration.
- The speed range in which the JOG operation can be set is 1 Hz to 500 kHz. If a value out of the range is set, the speed cannot be changed. The speed remains that before making this setting.
- When the JOG acceleration time or JOG deceleration time is set to 0 ms, the speed will be changed immediately.

10.9 Home Return

10.9.1 Types of Home Return

The home return is specified in the positioning parameter setting dialog box for each axis.

Name	Operation diagram	Operation and application
DOG method 1		<ul style="list-style-type: none"> • The leading edge of the first home input is set as a home position after the detection of the leading edge of the near home input. • Even when the limit input turns on, the motor rotation will be automatically reversed and the home return operation will continue. • This method is used when the home switch exists in the range that the near home switch is enabled, such as a system using a servo motor. This method can also be used when no home switch exists in the range that the near home switch is enabled.
DOG method 2		<ul style="list-style-type: none"> • The leading edge of a near home input is detected and it is set as a home position. • Even when the limit input turns on, the motor rotation will be automatically reversed and the home return operation will continue. • This method is used for performing the home return with the near home switch only.
DOG method 3		<ul style="list-style-type: none"> • The leading edge of the first home input in the home return direction set as a home position after the detection of a trailing edge (back end) of the near home input. • Even when the limit input turns on, the motor rotation will be automatically reversed and the home return operation will continue. • This method is used when no home switch exists in the range that the near home switch is enabled.
Home position method		<ul style="list-style-type: none"> • Moves the current position to the home return direction, and stops at the position where the leading edge of the home input is detected. This coordinate is set as the starting point. • When no home input exists in the home return direction, the limit input turns on and the operation stops. • This method is used for performing the home return with the home switch only. This method is compatible with the F171 instruction of the existing model FPsigma.

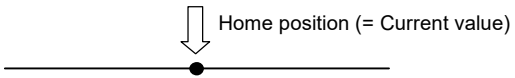
Name	Operation diagram	Operation and application
Data set method		<ul style="list-style-type: none"> • Performs the home return based on the home coordinate values in the axis setting area of positioning memory. • Performs the home return toward the home coordinate on the software. • When the starting point is within the limit switch, it cannot be started.

10.9.2 Operation Patterns of Home Return Operation

The operations vary according to selected home return methods and the difference in current positions.

■ DOG method 1 (Edge detection of near home switch + Home switch, based on front end)

The leading edge of the first home switch is set as a home position after the detection of the leading edge of the near home switch.

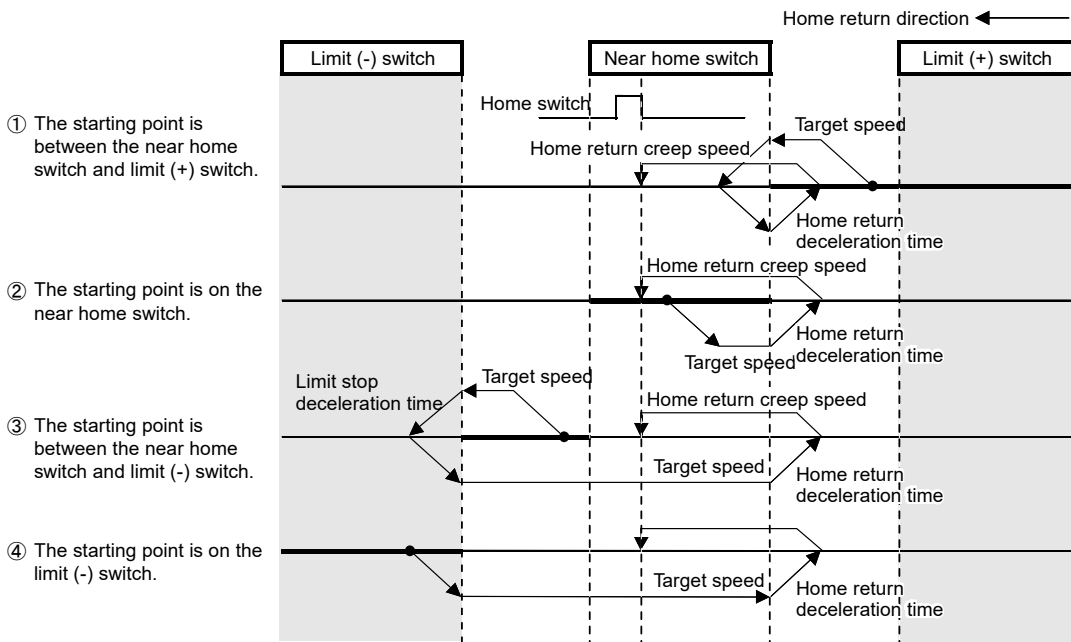

■ DOG method 2 (Edge detection of near home switch)

The leading edge of the near home switch is detected and it is set as a home position.

10.9 Home Return

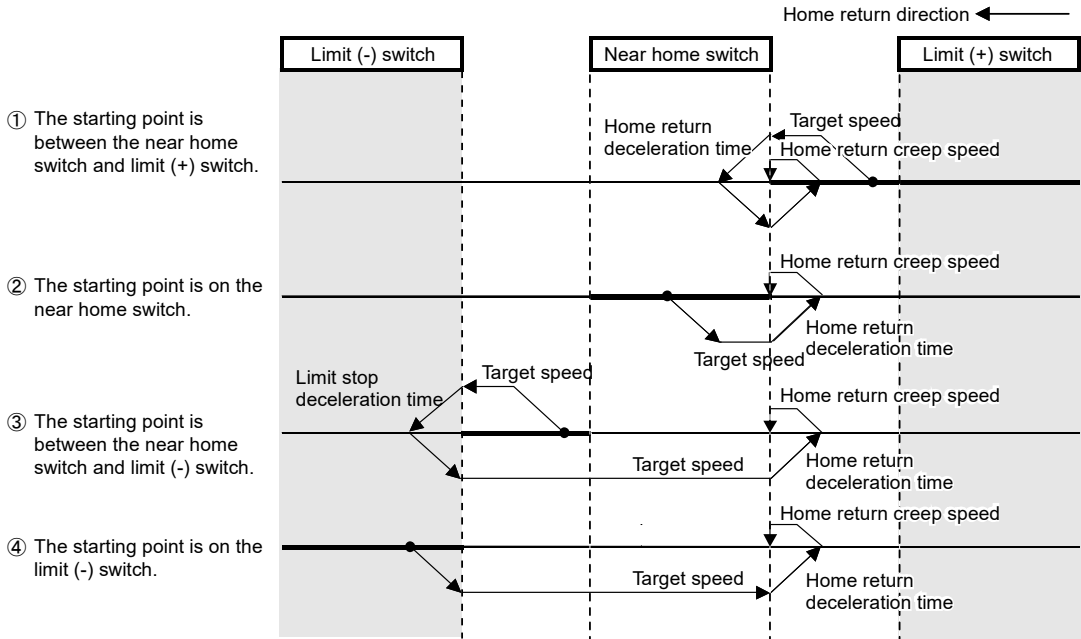

■ **DOG method 3 (Edge detection of near home switch + Home switch, based on back end)**

The leading edge of the first home switch in the home return direction is set as a home position after the detection of the trailing edge (back end) of the near home switch.

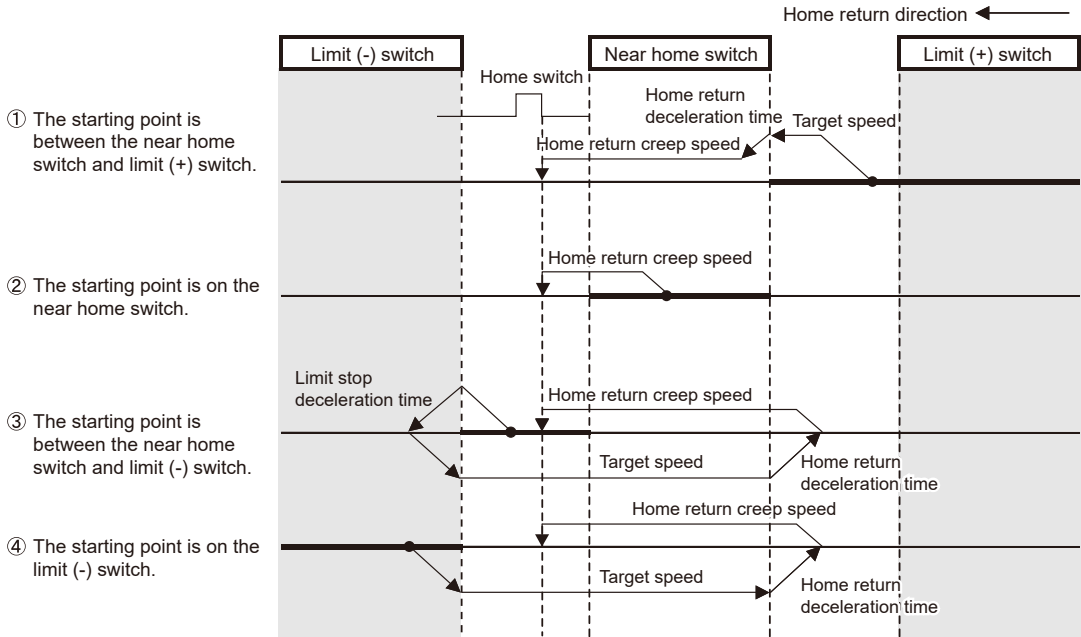

■ Home position method (Edge detection of home switch)

Moves the current position to the home return direction, and stops at the position where the leading edge of the first home switch is detected. This coordinate is set as a home position.

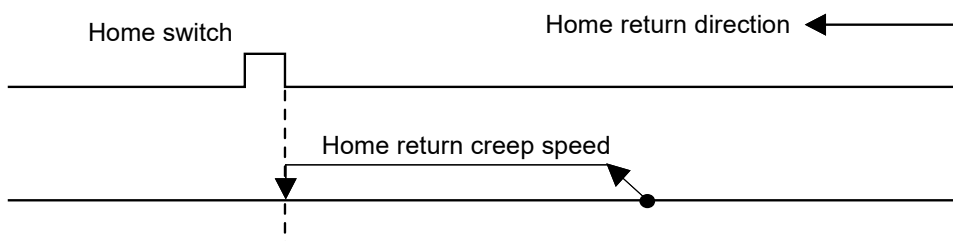

■ Data set method

Performs the home return based on the home coordinate values in the axis setting area of unit memories.

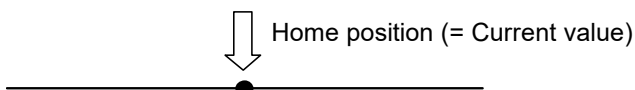

i Info.

- For details of addresses and settings of unit memories, refer to ["13.3 List of Unit Memories"](#).

10.9.3 Settings and Operations of Home Return

- The parameters for home return operations are specified in the "Positioning Parameter Setting" menu of Configurator PMX.
- When the home return start contact turns on, the pulse output starts and the home return operation is performed.
- In the following example, the DOG1 method is selected. After the start, it moves at a target speed and reverses at the time of near home detection. After the redetection of near home input, it moves at a creep speed until the home position is detected.

10.9 Home Return

■ Operation diagram

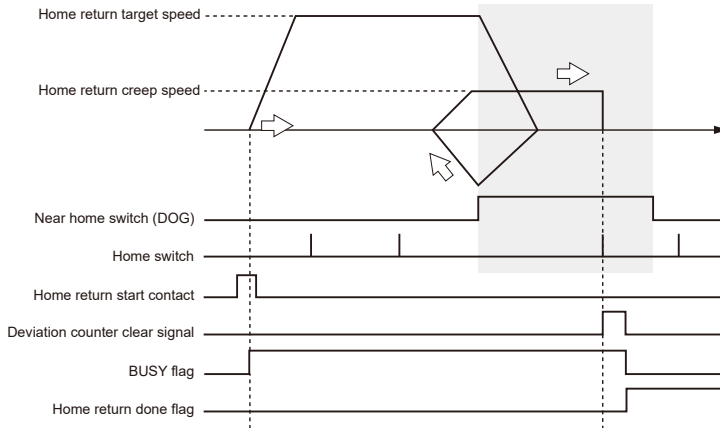

■ Operations of each contact

- The BUSY flags (X30-X33), which indicate that the motor is running, will turn on when the home return operation starts, and they will turn off when the operation completes.
- The deviation counter clear signal will turn on after the completion of the home return operation. The ON time is set in the axis setting area of the unit memories.
- The home return done flags (X38 to X3B), which indicate the completion of home return operation, will turn on when the current operation is completed, and they will be held until any operation of the positioning control, JOG operation and home return operation starts. The timing of turning on the flags is on the completion of the home return.

■ Settings

Item	Setting example	
Axis Setting Area	Home return method	DOG method 1
	Home return direction	Limit (-) direction
	Home return acceleration time (ms)	100 ms
	Home return deceleration time (ms)	100 ms
	Home return target speed	10000 pps
	Home return creep speed	1000 pps
	Deviation counter clear time	1 ms

■ Configurator PMX settings

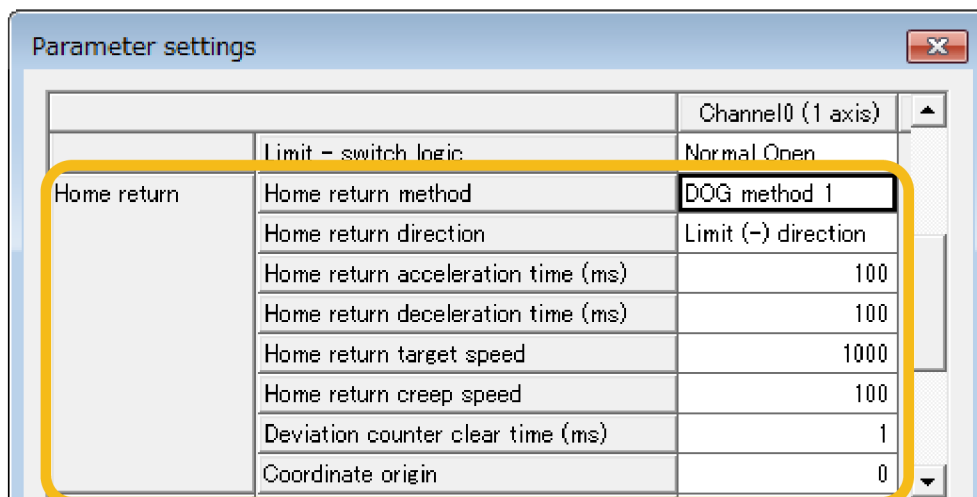

■ Allocation of I/O signals

Signal name	Application	I/O number			
		Axis 1	Axis 2	Axis 3	Axis 4
		CH0	CH1	CH2	CH3
BUSY	Control flag	X30	X31	X32	X33
HOME	Home return start	Y38	Y39	Y3A	Y3B

■ Sample program

The execution condition is differential execution.

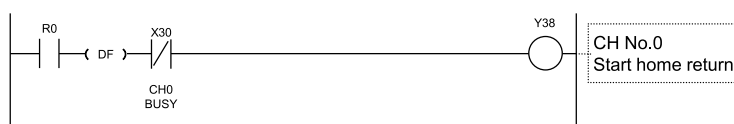

■ Operation at limit input

Condition	Direction	Limit status	Operation
At startup	Forward	Over limit input (+): ON	Executable ^(Note 2) ^(Note 3)
		Over limit input (-): ON	Executable ^(Note 3)
	Reverse	Over limit input (+): ON	Executable ^(Note 3)
		Over limit input (-): ON	Executable ^(Note 2) ^(Note 3)
During operation	Forward	Over limit input (+): ON	Automatic reverse operation ^(Note 4)
		Over limit input (-): ON edge ^(Note 1)	Limit stops, Error occurs.
	Reverse	Over limit input (+): ON edge ^(Note 1)	Limit stops, Error occurs.

10.9 Home Return

Condition	Direction	Limit status	Operation
		Over limit input (-): ON	Automatic reverse operation ^(Note 4)

(Note 1) Only when an edge signal is detected, the limit stop is performed.

(Note 2) In the case of home position method, it cannot be executed.

(Note 3) In the case of data set method, it cannot be executed.

(Note 4) Under some circumstances, ""Limit Stop or Error"" (Example) After detecting home position proximity, if the limit input is enabled during deceleration, a limit stop is performed without reverse operation.

10.10 Positioning Control

10.10.1 Types of Positioning Controls

■ Operation pattern

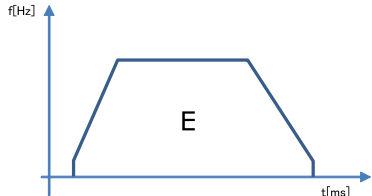
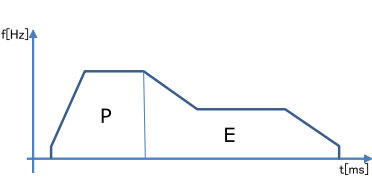
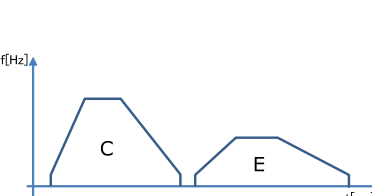
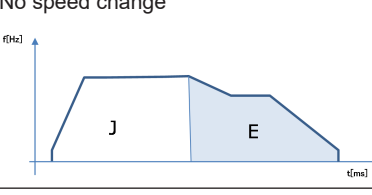
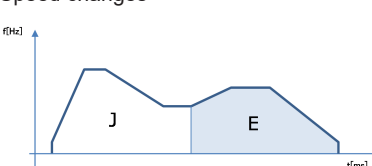
Name	Time chart	Operation and application	Repeat	Interpolation
E-point control		<ul style="list-style-type: none"> This is a method of control which is initiated up to an end point, and is referred to as "E-point control". This method is used for a first speed acceleration/deceleration. 	A	A
P-point control		<ul style="list-style-type: none"> This refers to control which passes through a "Pass Point", and is called "P-point control". This method is used for a second speed acceleration/deceleration. After the pulse output is performed for a specified movement amount, it shifts to the E-point control. 	A	A
C-point control		<ul style="list-style-type: none"> This refers to control which passes through a "Continuance Point", and is called "C-point control". This method is used for performing two successive first speed positioning control with different target speeds or acceleration/deceleration times. The time taken for transmitting from the C-point control to E-point control is specified as a dwell time. 	A	A
J-point control	<p>No speed change</p>  <p>Speed changes</p> 	<ul style="list-style-type: none"> This refers to control which passes through a speed point "JOG Operation Point", and is called "J-point control". After the start, it is controlled at specified speeds. Once the J-point positioning contact turns on, the positioning control starts. When the J-point control speed change flag is set, the speed changes. 	-	-

■ Selection of positioning operation modes

Positioning operation modes are selected on Configurator PMX.

10.10 Positioning Control

- For the E-point control, input settings in one row.
- For P-point, C-point and J-point controls, they should be combined with E-point control of the next step as a pair and the setting should be input in two rows.

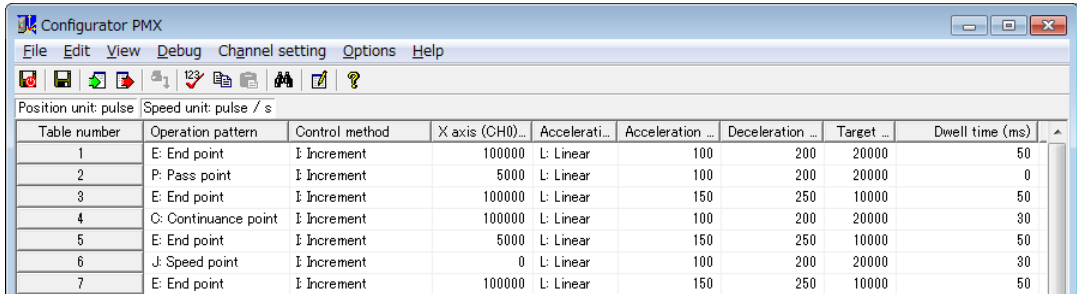

The screenshot shows the 'Configurator PMX' software window. The title bar includes 'File', 'Edit', 'View', 'Debug', 'Channel setting', 'Options', and 'Help'. Below the title bar is a toolbar with various icons. The main area displays a table with the following data:

Table number	Operation pattern	Control method	X axis (CH0)...	Accelerati...	Acceleration ...	Deceleration ...	Target ...	Dwell time (ms)
1	E: End point	I Increment	100000	L: Linear	100	200	20000	50
2	P: Pass point	I Increment	5000	L: Linear	100	200	20000	0
3	E: End point	I Increment	100000	L: Linear	150	250	10000	50
4	C: Continuance point	I Increment	100000	L: Linear	100	200	20000	30
5	E: End point	I Increment	5000	L: Linear	150	250	10000	50
6	J: Speed point	I Increment	0	L: Linear	100	200	20000	30
7	E: End point	I Increment	100000	L: Linear	150	250	10000	50

Info.

- When E: End point is not selected in the next row after P: Pass point, C: Continuance point or J: Speed point, the self-diagnostic error (error code 44: positioning error) is set to UM00066. For details of positioning error codes, refer to ["12.2.2 What to Do When Positioning Error Occurs"](#).

■ Settings of J-point control

- For J-point control, select "Increment" as a control method.
- For changing speed during J-point control, set the target speed after the change in the "Positioning Parameter" dialog box.

10.10.2 E-point Control (Single Speed Positioning)

- When the positioning table start contact or positioning simultaneous start contact turns on, the pulse output starts and the positioning control operation is performed.

■ Operation diagram

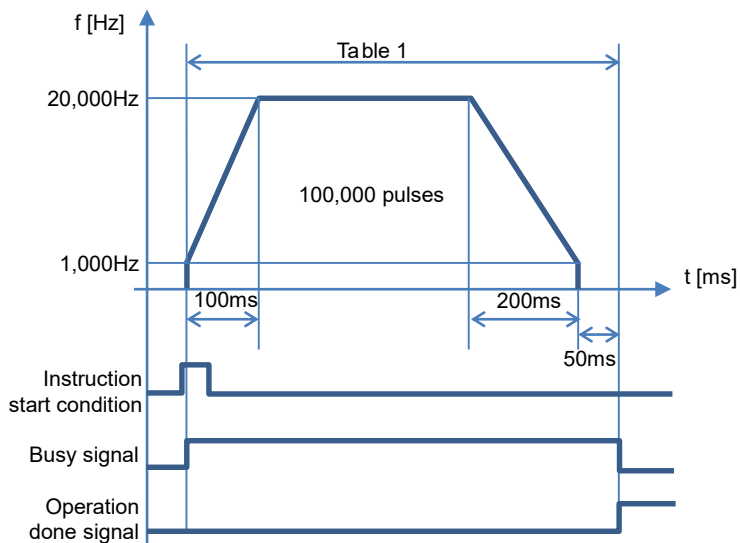

■ Operations of each contact

- The BUSY flags (X30-X33), which indicate that the motor is running, will turn on when the position control starts, and they will turn off when the operation completes.
- The operation done flags (X34-X37), which indicate the completion of operation, will turn on when the current operation is completed, and they will be held until the next positioning control, JOG operation or home return operation starts.

■ Settings

The parameters for position control operations are specified in the "Positioning Parameter Setting" menu and data table of Configurator PMX.

Item		Setting example
Axis Setting Area	Startup Speed	1,000 Hz
Table area	Table No.	Table 1
	Operation pattern	E-point control (End point control)
	Control method	Increment mode
	X-axis (CH0) movement amount	100,000 pulses
	Positioning acceleration time	100 ms
	Positioning deceleration time	200 ms
	Positioning target speed	20,000 Hz
	Dwell time	50 ms

10.10 Positioning Control

■ Configurator PMX settings

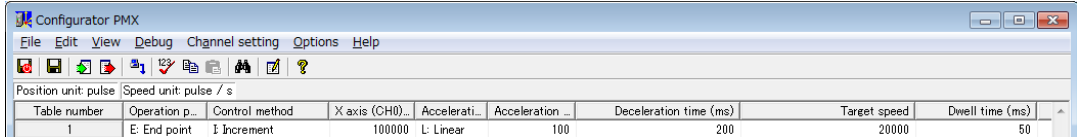
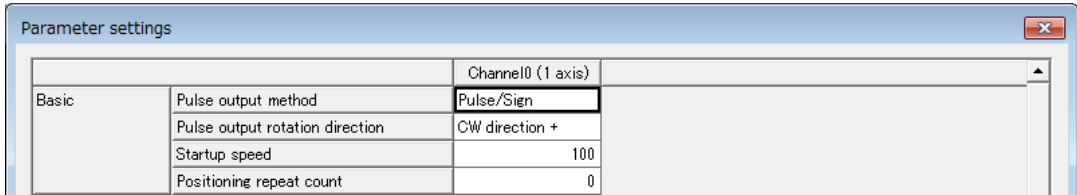

■ Allocation of I/O signals

Signal name	Application	I/O number			
		Axis 1	Axis 2	Axis 3	Axis 4
		CH0	CH1	CH2	CH3
BUSY	Control flag	X30	X31	X32	X33
POS	Positioning table start	Y30	Y31	Y32	Y33
MPOS	Positioning simultaneous start	Y34			

■ Sample program

The execution condition is differential execution.

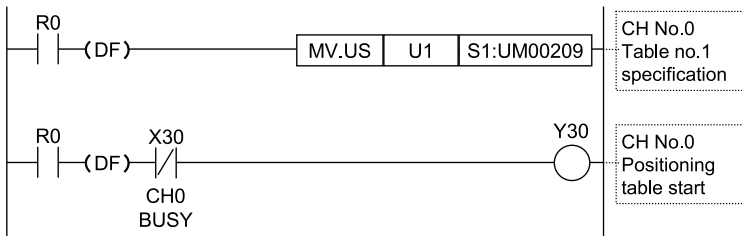

10.10.3 P-point Control (Double Speed Positioning)

- When the positioning table start contact or positioning simultaneous start contact turns on, the pulse output starts and the positioning control operation is performed.

■ Operation diagram

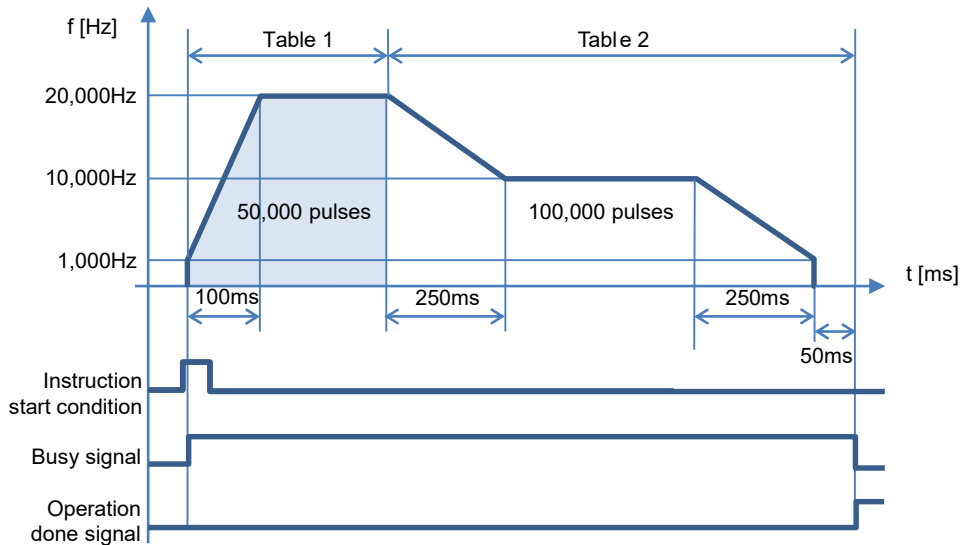

■ Operations of each contact

- The BUSY flags (X30-X33), which indicate that the motor is running, will turn on when the position control starts, and they will turn off when the operation completes.
- The operation done flags (X34-X37), which indicate the completion of operation, will turn on when the current operation is completed, and they will be held until the next positioning control, JOG operation or home return operation starts.

■ Settings

The parameters for position control operations are specified in the "Positioning Parameter Setting" menu and data table of Configurator PMX.

Item		Setting example	
Axis Setting Area	Startup Speed	1,000 Hz	
Table area	Table No.	Table 1	Table 2
	Operation pattern	P-point control (Pass point control)	E-point control (End point control)
	Control method	Increment mode	Increment mode
	X-axis (CH0) movement amount	50,000 pulses	100,000 pulses
	Positioning acceleration time	100 ms	150 ms
	Positioning deceleration time	200 ms	250 ms
	Positioning target speed	20,000 Hz	10,000 Hz
	Dwell time	-	50 ms

10.10 Positioning Control

■ Configurator PMX settings

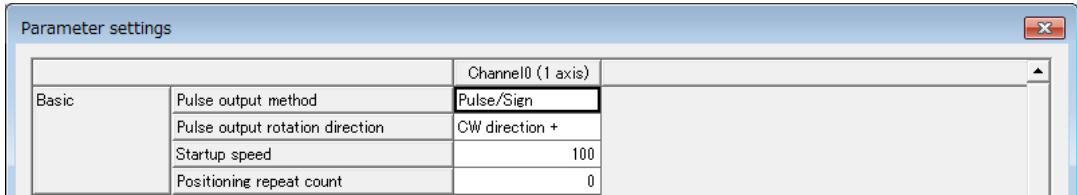

Table number	Operation p...	Control method	X axis (CH0) ...	Acceler...	Acceleration time...	Deceleration time ...	Target speed	Dwell time (ms)
1	P: Pass point	I Increment	50000	L: Linear	100	200	20000	0
2	E: End point	I Increment	100000	L: Linear	150	250	10000	50

■ Allocation of I/O signals

Signal name	Application	I/O number			
		Axis 1	Axis 2	Axis 3	Axis 4
		CH0	CH1	CH2	CH3
BUSY	Control flag	X30	X31	X32	X33
POS	Positioning table start	Y30	Y31	Y32	Y33
MPOS	Positioning simultaneous start	Y34			

■ Sample program

The execution condition is differential execution.

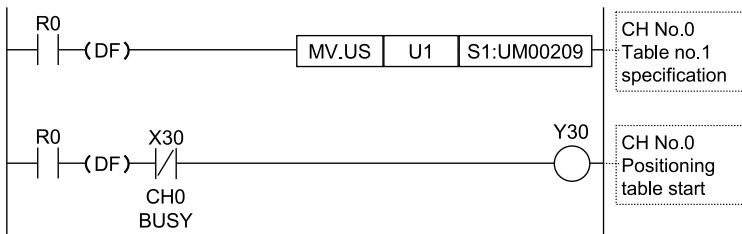

10.10.4 C-point control

- When the positioning table start contact or positioning simultaneous start contact turns on, the pulse output starts and the positioning control operation is performed.

■ Operation diagram

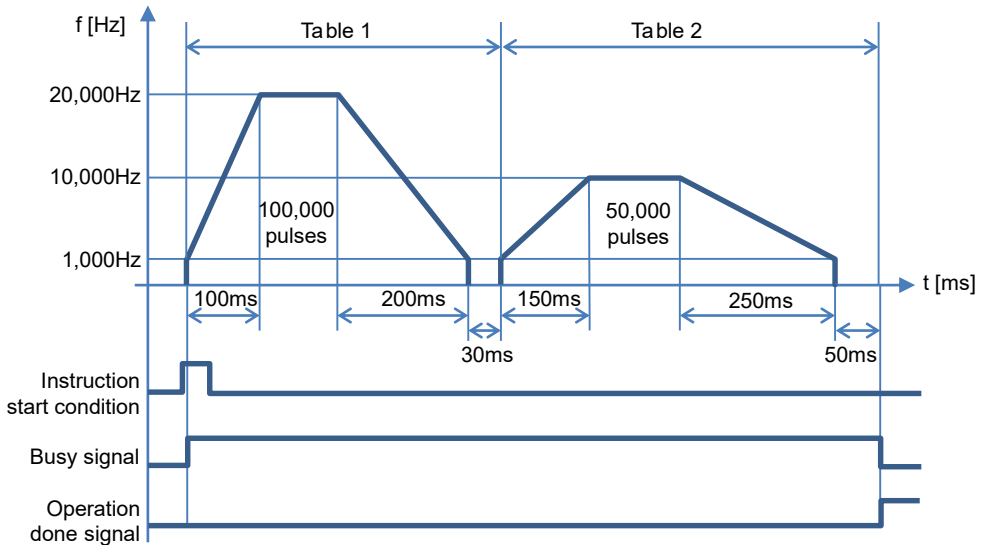

■ Operations of each contact

- The BUSY flags (X30-X33), which indicate that the motor is running, will turn on when the position control starts, and they will turn off when the operation completes.
- The operation done flags (X34-X37), which indicate the completion of operation, will turn on when the current operation is completed, and they will be held until the next positioning control, JOG operation or home return operation starts.

■ Settings

The parameters for position control operations are specified in the "Positioning Parameter Setting" menu and data table of Configurator PMX.

Item		Setting example	
Axis Setting Area	Startup Speed	1,000 Hz	
Table area	Table No.	Table 1	Table 2
	Operation pattern	C-point control (Continuance point control)	E-point control (End point control)
	Control method	Increment mode	Increment mode
	X-axis (CH0) movement amount	100,000 pulses	50,000 pulses
	Positioning acceleration time	100 ms	150 ms
	Positioning deceleration time	200 ms	250 ms
	Positioning target speed	20,000 Hz	10,000 Hz
	Dwell time	30 ms	50 ms

10.10 Positioning Control

■ Configurator PMX settings

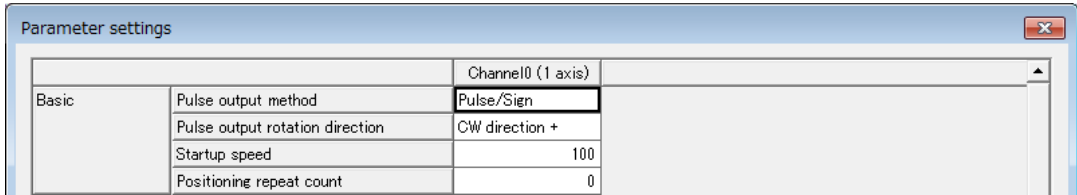

Table number	Operation p...	Control method	X axis (CH0) ...	Acceler...	Acceleration time...	Deceleration time ...	Target speed	Dwell time (ms)
1	C: Continua...	I: Increment	100000	L: Linear	100	200	20000	30
2	E: End point	I: Increment	50000	L: Linear	150	250	10000	50

■ Allocation of I/O signals

Signal name	Application	I/O number			
		Axis 1	Axis 2	Axis 3	Axis 4
		CH0	CH1	CH2	CH3
BUSY	Control flag	X30	X31	X32	X33
POS	Positioning table start	Y30	Y31	Y32	Y33
MPOS	Positioning simultaneous start	Y34			

■ Sample program

The execution condition is differential execution.

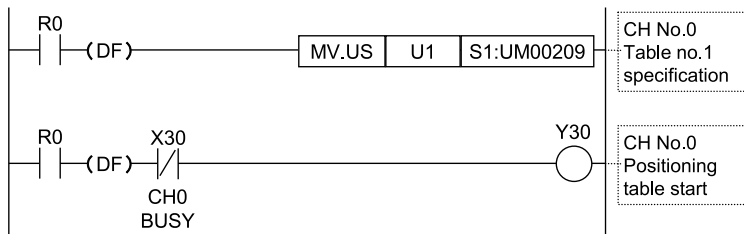

10.10.5 J-point Control (JOG Positioning)

- When the positioning table start contact or positioning simultaneous start contact turns on, the pulse output starts. In the J-point control, the unit operates at a target speed after the startup, and starts the position control when the J-point control positioning start input (X1, X5 or Y50, Y51) turns on.
- For J-point control, only "Increment" can be used as a control method.

■ **Operation diagram**

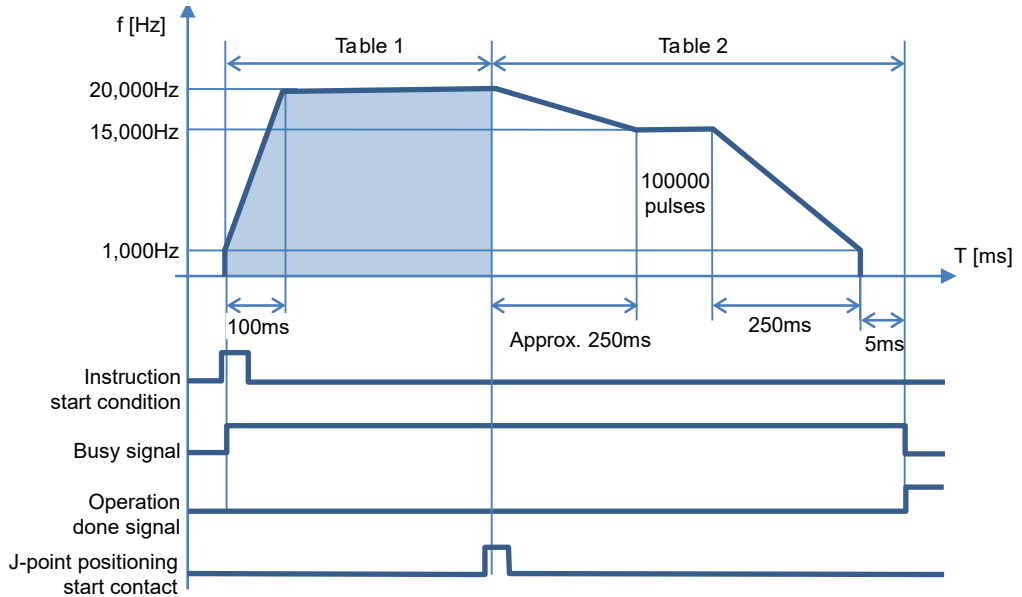

■ **Operations of each contact**

- The BUSY flags (X30, X31) will turn on when the operation starts and turn off when the operation is completed.
- The operation done flags (X34, X35) will turn on when the JOG operation is completed, and it will be held until the next positioning control, JOG operation, or home return operation starts.
- Positioning control will start when J-point control positioning start inputs (X1, X5 or Y50, Y51) turn on. However, when the inputs (X1, X5) are used as near home inputs, J-point control will not be performed.

■ **Settings**

The parameters for position control operations are specified in the "Positioning Parameter Setting" menu and data table of Configurator PMX.

Item		Setting example	
Axis Setting Area	Startup Speed	1,000 Hz	
	J-point change speed	10,000 Hz	
Table area	Table No.	Table 1	Table 2
	Operation pattern	J-point control (Speed control)	E-point control (End point control)
	Control method	Increment mode	Increment mode
	X-axis (CH0) movement amount	-	100,000 pulses
	Positioning acceleration time	100 ms	150 ms

10.10 Positioning Control

Item		Setting example	
	Positioning deceleration time	200 ms	250 ms
	Positioning target speed	20,000 Hz	15,000 Hz
	Dwell time	30 ms	5 ms

■ Configurator PMX settings

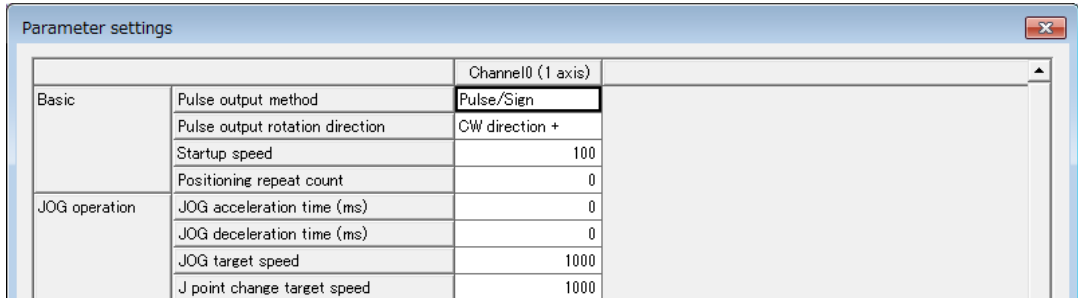

Table number	Operation p...	Control method	X axis (CH0) ...	Acceler...	Acceleration time...	Deceleration time ...	Target speed	Dwell time (ms)
1	J: Speed poi...	I: Increment	0	L: Linear	100	200	20000	30
2	E: End point	I: Increment	100000	L: Linear	150	250	10000	50

■ Allocation of I/O signals

Signal name	Application	I/O number			
		Axis 1	Axis 2	Axis 3	Axis 4
		CH0	CH1	CH2	CH3
BUSY	Control flag	X30	X31	X32	X33
POS	Positioning table start	Y30	Y31	Y32	Y33
MPOS	Positioning simultaneous start	Y34			

■ Sample program

The execution condition is differential execution.

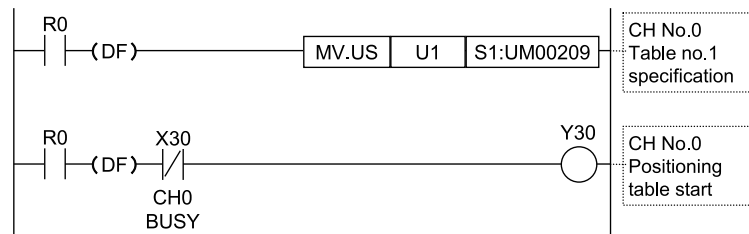

10.10.6 J-point Control (JOG Positioning: Speed Changes)

- In the J-point control, the speed can be changed while controlling the speed after the start.
- After starting the J-point control, the unit operates at the speed specified in the positioning parameters of Configurator PMX.
- The speed changes when the J-point control speed change flag (Y54, Y55) turns on.
- For J-point control, only "Increment" can be used as a control method.

■ Operation diagram

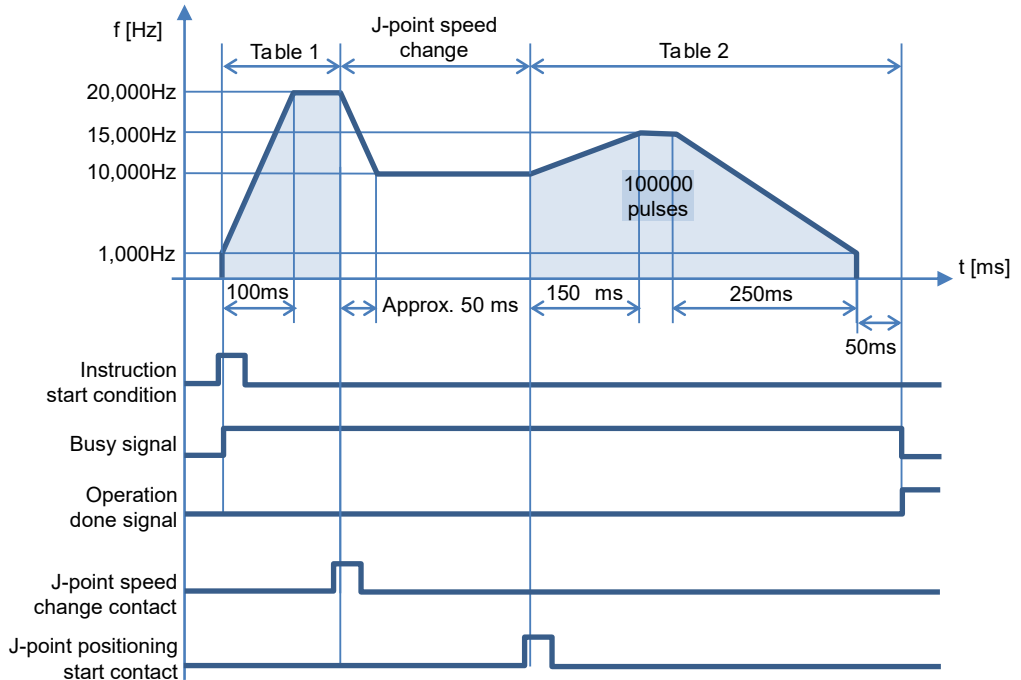

■ Operations of each contact

- The BUSY flags (X30, X31) will turn on when the operation starts and turn off when the operation is completed.
- The operation done flags (X34, X35) will turn on when the JOG operation is completed, and it will be held until the next positioning control, JOG operation, or home return operation starts.
- The target speed will be changed when the J-point control speed change flags (Y54, Y55) turn on. The change will be enabled at the edge where the contact turns on.
- Positioning control will start when J-point control positioning start inputs (X1, X5 or Y50, Y51) turn on. However, when the inputs (X1, X5) are used as near home inputs, J-point control will not be performed.

■ Characteristics of acceleration/deceleration zone when changing speeds

- The speed of speed change zone changes by approx. 100 μ s when changing the speed in the J-point control. The speed variation is obtained by the following formula.

10.10 Positioning Control

(J-point table target speed - Startup speed) / (J-point table acceleration time or J-point table deceleration time)

■ Settings

The parameters for position control operations are specified in the "Positioning Parameter Setting" menu and data table of Configurator PMX.

Item		Setting example	
Axis Setting Area	Startup Speed	1,000 Hz	
	J-point change speed	10,000 Hz	
Table area	Table No.	Table 1	Table 2
	Operation pattern	J-point control (Speed control)	E-point control (End point control)
	Control method	Increment mode	Increment mode
	X-axis (CH0) movement amount	-	100,000 pulses
	Positioning acceleration time	100 ms	150 ms
	Positioning deceleration time	200 ms	250 ms
	Positioning target speed	20,000 Hz	15,000 Hz
Dwell time	30 ms	50 ms	

■ Configurator PMX settings

Table number	Operation p...	Control method	X axis (CH0) ...	Accelera...	Acceleration time...	Deceleration time ...	Target speed	Dwell time (ms)
1	J: Speed poi...	I Increment	0	L: Linear	100	200	20000	30
2	E: End point	I Increment	100000	L: Linear	150	250	10000	50

Parameter settings		Channel0 (1 axis)
	Home return creep speed	100
	Deviation counter clear time (ms)	1
	Coordinate origin	0
JOG operation	JOG acceleration time (ms)	100
	JOG deceleration time (ms)	100
	JOG target speed	10000
	J point change target speed	10000

■ Allocation of I/O signals

Signal name	Application	I/O number			
		Axis 1	Axis 2	Axis 3	Axis 4
		CH0	CH1	CH2	CH3
BUSY	Control flag	X30	X31	X32	X33
POS	Positioning table start	Y30	Y31	Y32	Y33
MPOS	Positioning simultaneous start	Y34			
JPOS SP	J point control speed change	Y54	Y55	—	—

■ Sample program

The execution condition is differential execution.

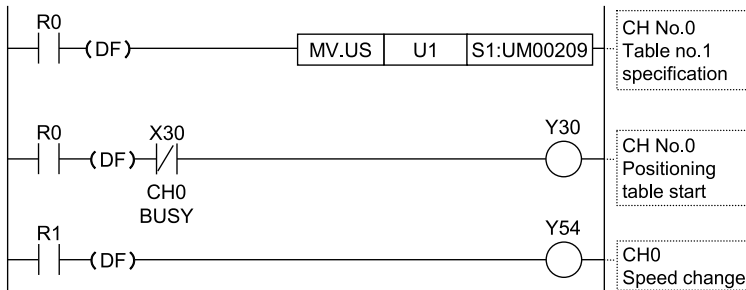

■ Behaviors when the speed change contact turns on while the positioning unit is accelerating or decelerating the speed

- A speed change is possible during J-point control, but impossible during acceleration or deceleration.
- A speed change will be made after the positioning unit goes to a constant speed when the speed change signal turns on during acceleration or deceleration.

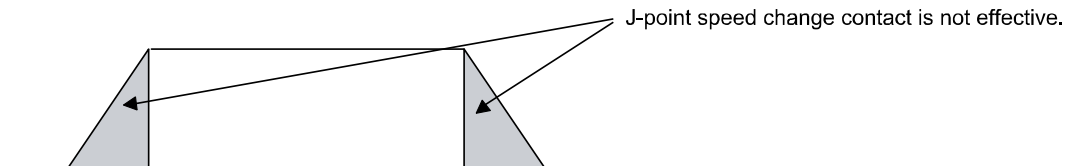

10.10 Positioning Control

Info.

- Specify parameters for the start of operation in the positioning data table. The parameters for changing speeds are specified in the **Channel setting>Parameter settings** menu. For details about parameter settings, refer to ""10.5.2 Parameter Settings"".
- J-point control can be used for single-axis control only. It is not available for interpolation control. For details about how to use axes, refer to ""10.5.1 Used Channel Setting"".
- Set the unit to increment mode to implement E-point control with positions specified after J-point control is implemented.
- Speed control is performed while the positioning unit is in J-point control, in which case, be sure to input the amount of movement for positioning with a value that can secure a target constant-speed area.

10.10.7 Programming Cautions

■ Programming cautions

- The last table should be set to E: End point.
- If any value such as a movement amount, acceleration time, deceleration time or target speed is out of the specified range, a positioning error will occur when the position control starts.
- The startup contact and flag numbers vary depending on channel numbers (axis numbers).

■ Operation at limit input

Conditions	Direction	Limit status	Operation
When each control starts	Forward	Over limit input (+): ON	Not executable, Error occurs.
		Over limit input (-): ON	Not executable, Error occurs.
	Reverse	Over limit input (+): ON	Not executable, Error occurs.
		Over limit input (-): ON	Not executable, Error occurs.
When each control is performed	Forward	Over limit input (+): ON	Limit stops, Error occurs.
		Over limit input (-): ON	Limit stops, Error occurs.
	Reverse	Over limit input (+): ON	Limit stops, Error occurs.
		Over limit input (-): ON	Limit stops, Error occurs.

10.11 Repeat Operation

10.11.1 Overview of Repeat Operation

- When the positioning table start contact is on, the unit repeats the operation set in the positioning table.

■ Conditions of repeat control

Item	Repeat control is available	Repeat control is unavailable
Operation pattern	E-point control, P-point control + E-point control, C-point control + E-point control	JOG operation, J-point control, Interpolation control
Control method	Increment mode	Absolute mode
Dwell time setting	Set the table of E-point control to 1 ms or more.	When setting 0 ms.

■ Operation diagram (Setting operation on the table)

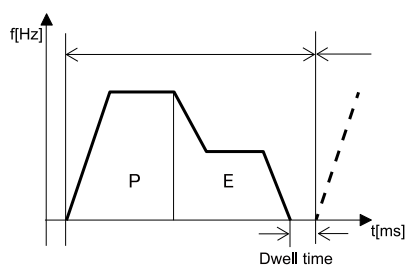

■ Operation diagram (Repeat operation)

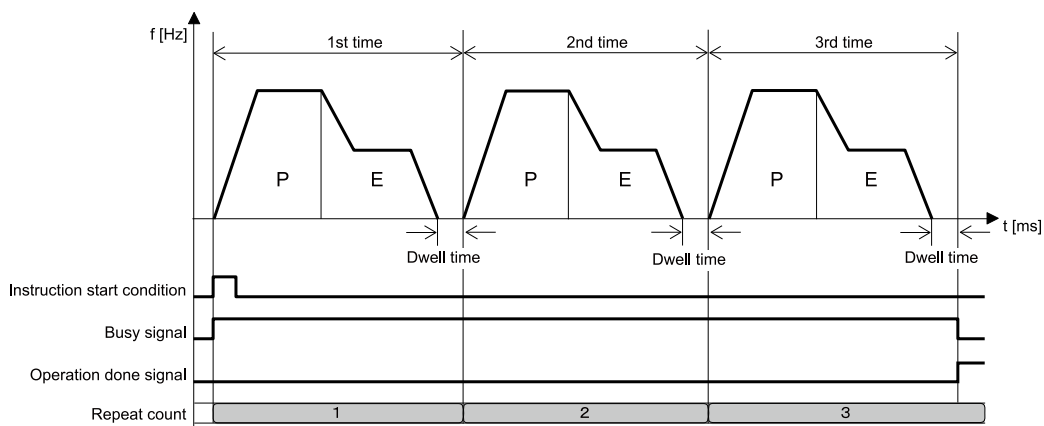

■ Configurator PMX setting items

The repeat count is specified for executing the repeat control in Configurator PMX.

Parameter name	Unit	Default	Settings	
Positioning repeat count	times	0	0 or 1	Not repeat an operation.

10.11 Repeat Operation

Parameter name	Unit	Default	Settings	
			2 to 254	Repeat an operation for a specified number of times.
			255	Repeat an operation infinitely.

■ Configurator PMX settings

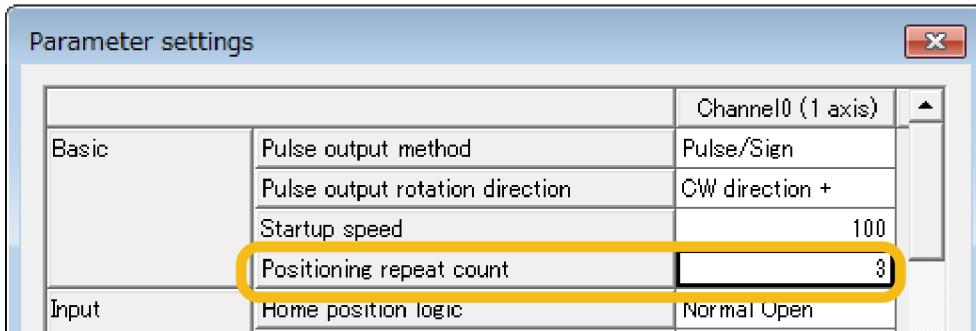

i Info.

- When selecting ""255: Repeat infinitely"" in the positioning repeat count parameter, program this to stop the operation using the deceleration stop function.

10.11.2 Settings and Operations of Repeat Operation

- When the positioning table start contact or positioning simultaneous start contact turns on, the pulse output starts.
- After starting the instruction, the unit executes the pulse output for a specified repeat count and then stops the operation. For setting to execute the operation infinitely, use this function in combination with the deceleration stop function.

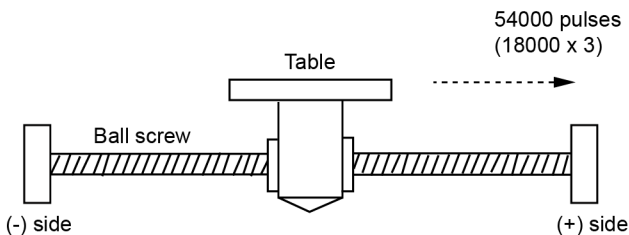

■ Operation diagram

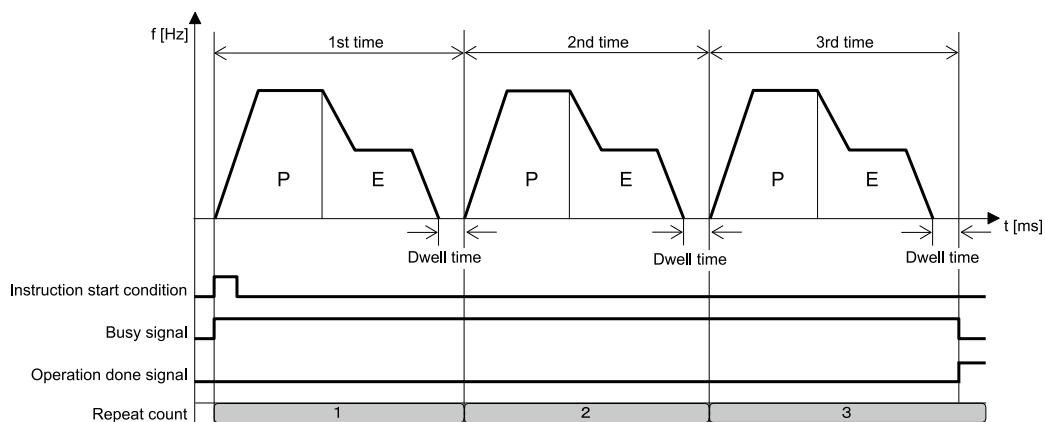

■ Operations of each contact

- The BUSY flags (X30-X33), which indicate that the motor is running, will turn on when the position control starts, and they will turn off when the set repeat operation completes.
- The operation done flags (X34-X37), which indicate the completion of operation, will turn on when the current operation is completed, and they will be held until the next positioning control, JOG operation or home return operation starts. Those flags do not turn off in the middle of the repeat operation.

■ Settings

The parameter for the repeat count is specified in the "positioning parameter setting" menu in Configurator PMX.

Item		Setting example	
Common Area	Axis setting	Turn on the single axis setting for an appropriate axis.	
	Positioning repeat count	3	
Axis Setting Area	Pulse output control code	Set in accordance with system configuration.	
	Startup Speed	1,000 Hz	
Table area	Table No.	Table 1	Table 2
	Operation pattern	P-point control (Pass point control)	E-point control (End point control)
	Control method	Increment mode	Increment mode
	X-axis (CH0) movement amount	5,000 pulses	10,000 pulses
	Positioning acceleration time	100 ms	150 ms
	Positioning deceleration time	200 ms	250 ms
	Positioning target speed	20,000 Hz	10,000 Hz
Dwell time	-	50 ms	

10.11 Repeat Operation

■ Configurator PMX settings

Table number	Operation p...	Control method	X axis (CH0) ...	Acceler...	Acceleration time...	Deceleration time ...	Target speed	Dwell time (ms)
1	P: Pass point	I Increment	50000	L: Linear	100	200	20000	0
2	E: End point	I Increment	100000	L: Linear	150	250	10000	50

Parameter settings		Channel0 (1 axis)
Basic	Pulse output method	Pulse/Sign
	Pulse output rotation direction	CW direction +
	Startup speed	100
	Positioning repeat count	3
Input	Home position logic	Normal Open

■ Allocation of I/O signals

Signal name	Application	I/O number			
		Axis 1	Axis 2	Axis 3	Axis 4
		CH0	CH1	CH2	CH3
BUSY	Control flag	X30	X31	X32	X33
POS	Positioning table start	Y30	Y31	Y32	Y33
MPOS	Positioning simultaneous start	Y34			

■ Sample program

The execution condition is differential execution.

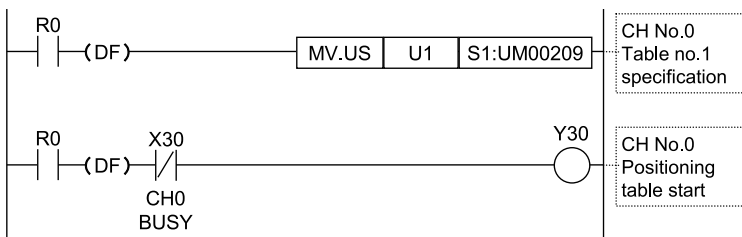

10.11.3 Stop Operation During Repeat Operation

- When setting the repeat function, the operation at the time of deceleration stop varies as follows.

■ Operation at the time of deceleration stop (Repeating E-point control)

When the unit detects a deceleration stop, the unit will come to a stop after repeating positioning control $N+2$ times. However, the unit will stop the control when reaching the set repeat count.

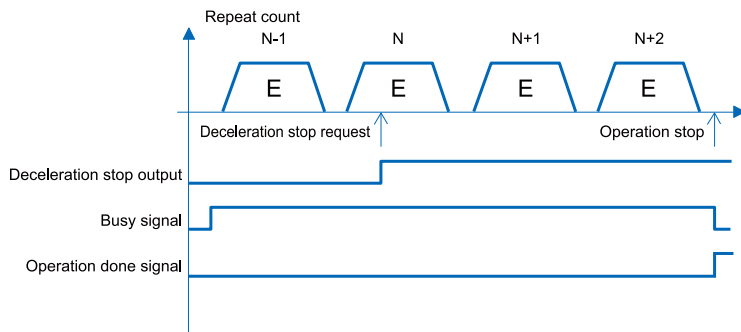

■ Operation at the time of deceleration stop (Repeating P-point control, C-point control)

When the unit detects a deceleration stop, it stops the operation after repeating the positioning control $N+1$ times. However, the unit will stop the control when reaching the set repeat count.

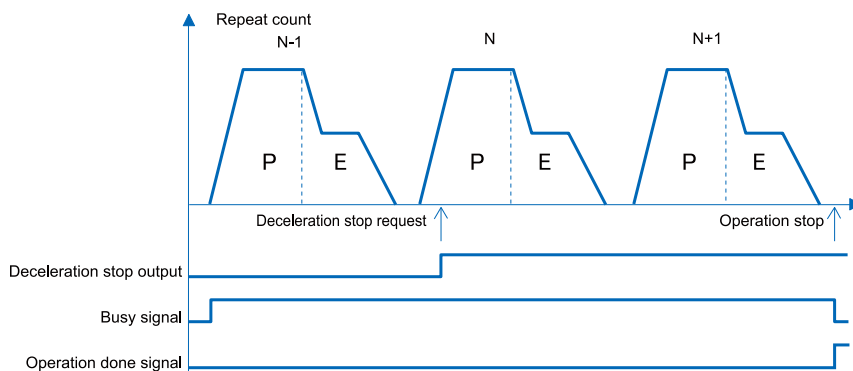

i Info.

- When a system stop is executed, the unit will stop the pulse output immediately without repetitive operations.
- When an emergency stop is executed, the unit will stop the pulse output after a specified emergency stop setting time without repetitive operations.

10.12 Linear Interpolation Control

10.12 Linear Interpolation Control

10.12.1 Overview

The interpolation control is available under the following conditions.

■ Combinations of interpolation control

Interpolation axis 1		Interpolation axis 2	
X-axis	Y-axis	X-axis	Y-axis
CH0	CH1	CH2	CH3

■ Conditions of interpolation control

Item	Condition under which interpolation control is executable	
	Executable	Not executable
Operation pattern	E-point control P-point control + E-point control C-point control + E-point control	JOG operation Home Return ^(Note 1) J-point control
Control method	Increment mode, Absolute mode	-

(Note 1) In the home return operation, home return start contacts turn on for each channel corresponding to X and Y axes. The trajectory is not linear interpolation.

■ Setting method of speed

Item	Composite speed	Long axis speed
Operation		
Setting method	Specify the speed combining the speed of X and Y axes.	Specify the speed for the axis whose movement amount is large.

(Note 1) When specifying the same value, the major axis speed is faster than the composite speed.

10.12.2 Setting and Operation of Linear Interpolation

The example below is a case of E-point control with the unit installed in slot 1. The X axis is set to the 1st axis and the Y axis is set to the 2nd axis. The movement amount setting is the increment method, and the unit is set to pulse.

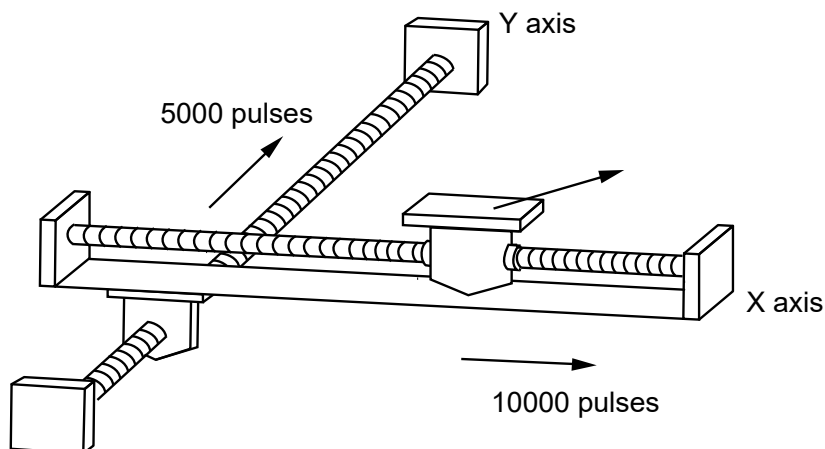

■ Operation diagram

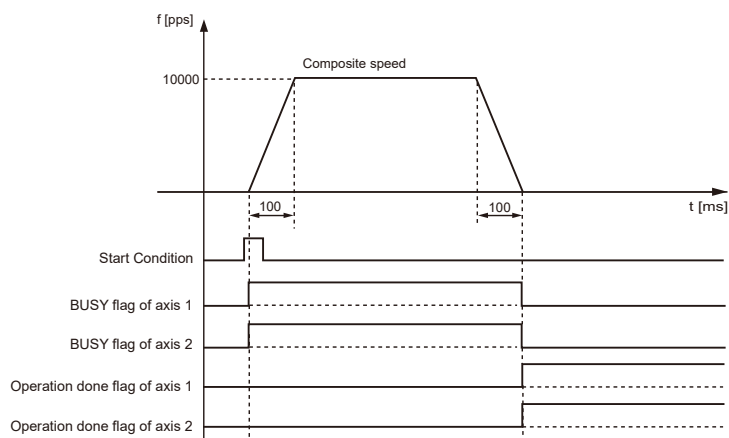

■ Operations of each contact

- The BUSY flags (X30, X31), which indicates that the motor is running, will turn on when the positioning control starts, and it will turn off when the operation completes.
- The operation done flags of axes 1 and 2 (X34, X35), which indicates the completion of operation, will turn on when the current operation is completed, and it will be held until the next positioning control, JOG operation or home return operation starts.

■ Settings

Item		Setting example
Common Area	Axis setting	Turn on the single axis setting for an appropriate axis.
	Positioning repeat count	0
Axis Setting Area	Pulse output control code	Set in accordance with system configuration.
	Startup Speed	1,000 Hz
Table area	Operation pattern	E: End point

10.12 Linear Interpolation Control

Item		Setting example
	Interpolation operation	0: Linear (Composite speed)
	Control method	I: Increment
	X-axis movement amount	10000 pulses
	Y-axis movement amount	5000 pulses
	Acceleration/ deceleration type	L: Linear
	Acceleration time (ms)	100 ms
	Deceleration time (ms)	100 ms
	Interpolation speed	10000 pps
	Dwell time	0 ms

Allocation of I/O signals

Signal name	Application	I/O number			
		Axis 1	Axis 2	Axis 3	Axis 4
		CH0	CH1	CH2	CH3
BUSY	Control flag	X30	X31	X32	X33
POS	Positioning table start	Y30	Y31	Y32	Y33

Sample program

The execution condition is differential execution.

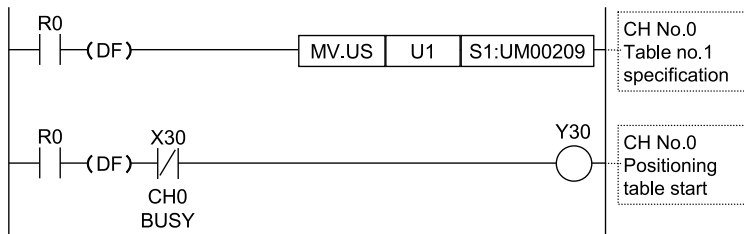

Cautions on Programming

- Specify a smaller channel number in the same group for starting the interpolation control.
- If any value such as a movement amount, acceleration time, deceleration time or target speed is out of the specified range, a positioning error will occur when the position control starts.
- The startup contact and flag numbers vary depending on channel numbers (axis numbers).

10.13 Operational Difference Between Speed Parameters

10.13.1 Startup speed

- The startup speed is the parameter for setting the initial speed when starting each operation and the speed when finishing each operation.
- The startup speed is common to each control of the JOG operation, home return, E-point control, P-point control, C-point control and J-point control operations. It is set for each channel number (axis number).

■ Setting method of startup speed

It is set in the “Parameter settings” dialog box of Configurator PMX.

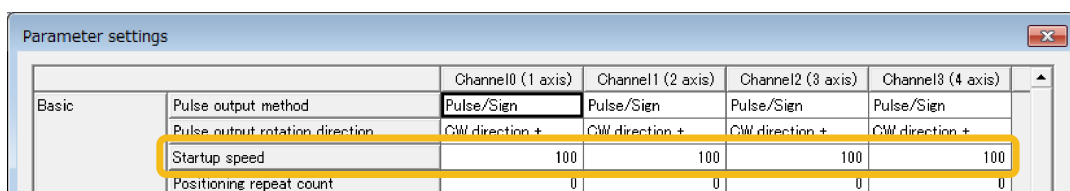

■ Precautions when setting the startup speed

- The home return creep speed setting is not influenced by the startup speed in the home return operation.
- The target speed of each operation is not influenced by the startup speed. Each operation is performed at each specified target speed regardless of the setting of startup speed.

10.13.2 Operation Patterns and Start Speed Settings

Operation pattern	Startup speed setting		
JOG operation		(1)	Startup speed
		(2)	Target speed

10.13 Operational Difference Between Speed Parameters

Operation pattern	Startup speed setting		
Home return		(1)	Startup speed
		(2)	Target speed
		(3)	Creep speed
E-point control		(1)	Startup speed
		(2)	Target speed
P-point control		(1)	Startup speed
		(2)	P-point target speed
		(3)	E-point target speed
C-point control		(1)	Startup speed
		(2)	C-point target speed
		(3)	E-point target speed
J-point control		(1)	Startup speed
		(2)	J-point target speed
		(3)	J-point change speed
		(4)	E-point target speed

10.14 Other Characteristics

10.14.1 Memory Backup

- Data in unit memories are cleared when the power is turned off.
- When the power is turned on again, data is preset in the parameters saved in the non-volatile memory within FP7 CPU Unit.
- The contents of unit memories will be held when changing the RUN mode to PROG. mode.

10.14.2 Activation of Each Operation

- When any of the JOG operation, home return and position control is activated, it does not transit to other operation even if an instruction to activate the other instruction turns on. Create a program to confirm the busy signals (X30 to X33) allocated to each axis and to start instructions.
- Stop operations (system stop, emergency stop, limit stop, deceleration stop) have priority even during other operations. Each operation is executed by turning on the stop signal allocated to each axis.

10.14.3 Operation When CPU Mode Changes From RUN To PROG.

- When the mode of CPU Unit changes from RUN to PROG. after starting the JOG operation, home return or position control (E-point control, P-point control, C-point control, J-point control), each operation stops.
- As well as the execution of the system stop, the unit stops the pulse output immediately.

(MEMO)

11 Other Functions

11.1 Creating of Ladder Programs Using Templates	11-2
11.1.1 Overview of Template Input Function	11-2
11.1.2 Creating Reading/Writing Program	11-3

11.1 Creating of Ladder Programs Using Templates

11.1 Creating of Ladder Programs Using Templates

11.1.1 Overview of Template Input Function

In FPCWIN GR7, it is possible to select unit memory numbers using templates and easily create ladder programs.

■ Appearance of Template input screen

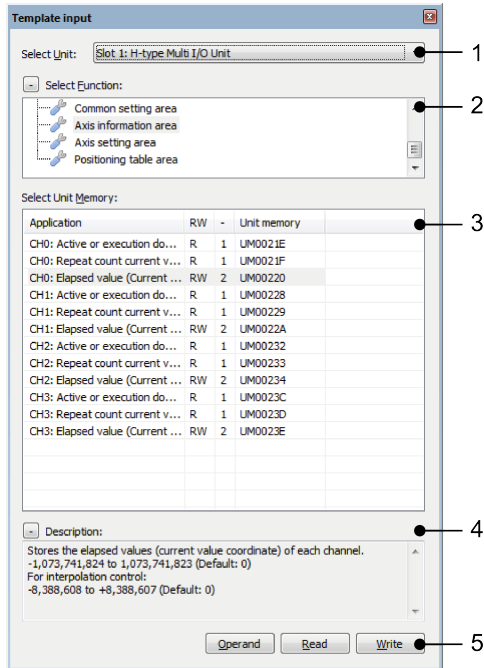

1	Select Unit	Select an arbitrary unit from connected units.
2	Select Function	Select items in accordance with used functions. Items vary according to a selected unit.
3	Select Unit Memory	Select applications and unit memory numbers you want to insert a program. ""R"" is used only for reading programs. ""RW"" is used for both reading and writing programs.
4	Description	Displays the detailed descriptions of each unit memory.
5	Operation button	<p>Operand: Click for changing specified values of operands.</p> <p>Read: Click for creating a program to read a selected unit memory. An access unit is also automatically created according to a selected unit memory.</p> <p>Write: Click for creating a program to write data to a selected unit memory. An access unit is also automatically created according to a selected unit memory.</p>

11.1.2 Creating Reading/Writing Program

The following procedure describes the process when the multi I/O unit has been already allocated in the I/O map.

1 2 Procedure

1. In the menu bar, select **Edit>Template input**
The "template input" screen will open.

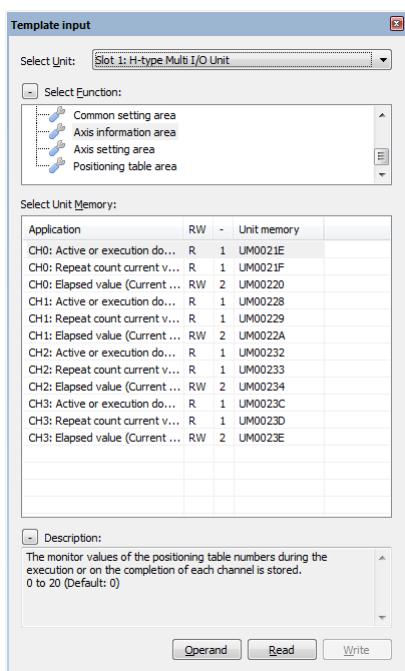

2. Move the cursor to a desired insertion position and select a desired unit memory.

11.1 Creating of Ladder Programs Using Templates

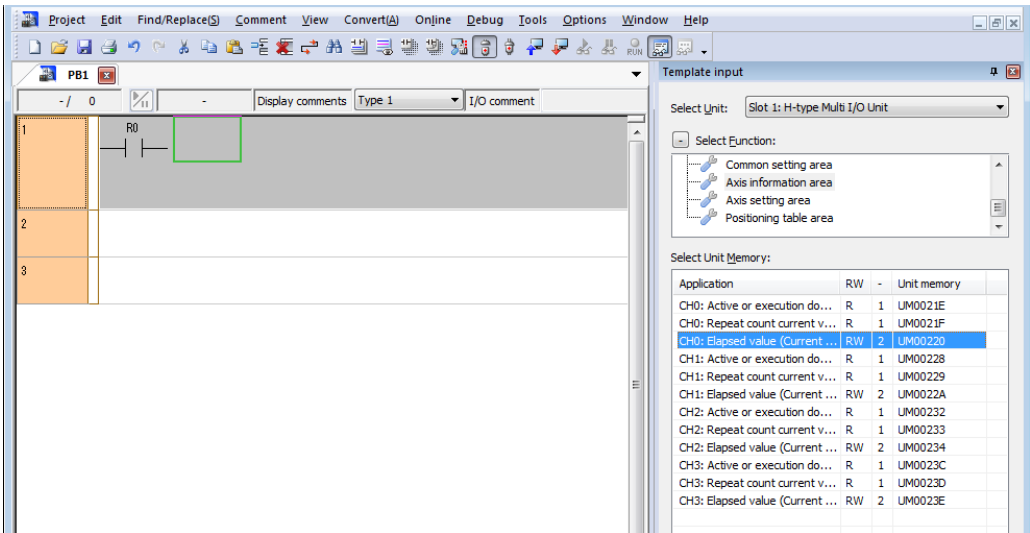

3. Click the "[Read]" button.
Once a program is created, specify an arbitrary operand.

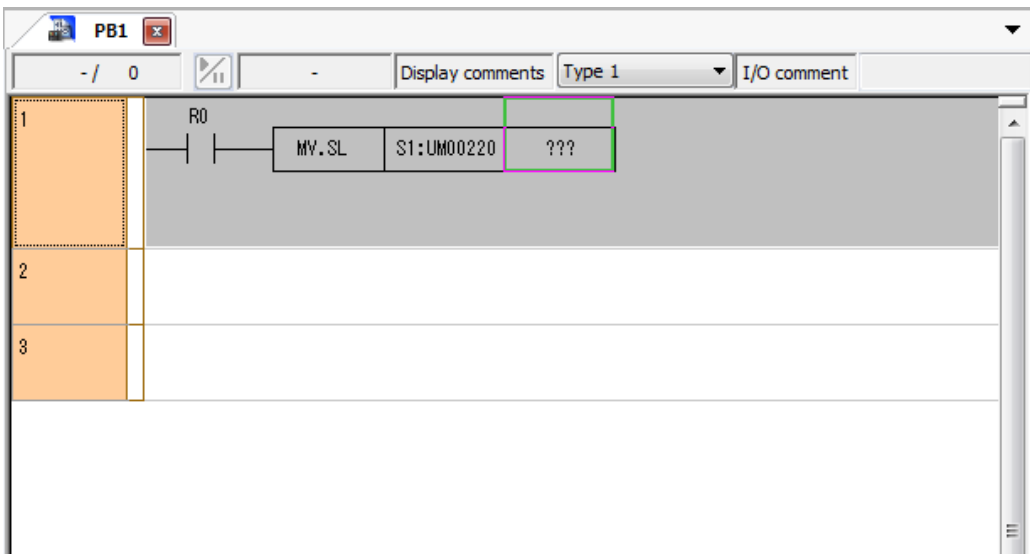

i Info.

- Using the template input for changing operands

The template input can also be used for changing the operands of created programs or for inputting commands manually.

Move the cursor to a position you want to change and select the unit memory, and then click the "[Operand]" button.



The operand is changed.

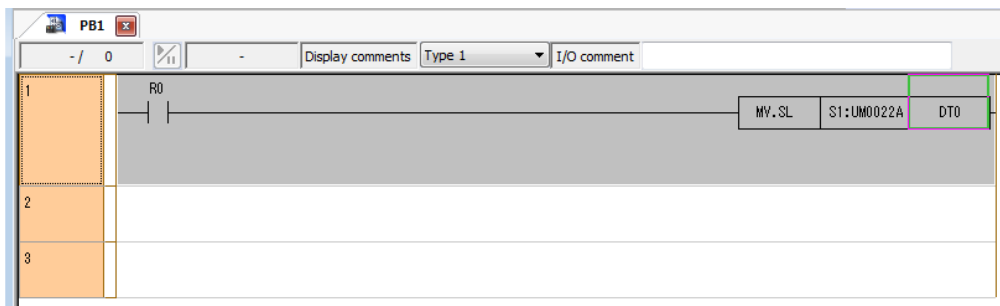

(MEMO)

12 Troubleshooting

12.1	Confirming Errors Using Self-diagnostic Function	12-2
12.1.1	Checking the LED Display of Unit	12-2
12.1.2	Operation Mode When an Error Occurs	12-2
12.2	Troubleshooting	12-4
12.2.1	ERR LED Turns ON on the Unit.....	12-4
12.2.2	What to Do When Positioning Error Occurs.....	12-5
12.2.3	ERR LED is Flashing on the Unit.....	12-7

12.1 Confirming Errors Using Self-diagnostic Function

12.1 Confirming Errors Using Self-diagnostic Function

12.1.1 Checking the LED Display of Unit

FP7 Multi I/O Unit has a self-diagnostic function which identifies errors and stops operation if necessary. The types of the self-diagnostic function are alarms, errors and warnings. When an error occurs, check the ERR.LED state and error type, and monitor the unit memory in which the code is stored.

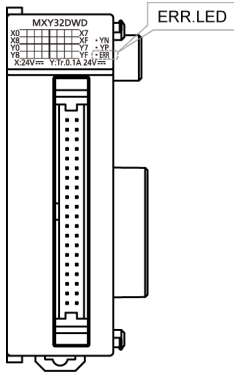

ERR LED state	Item	State	Operation of CPU unit	Solution
LED ON	Alarm (H type only)	Alarm occurs.	Stops the operation.	Refer to ""12.2.1 ERR LED Turns ON on the Unit"".
LED ON	Error 1	Unit error occurs.	Stops the operation.	Monitor UM00064 and check the error code. For details of error codes, refer to ""12.2.1 ERR LED Turns ON on the Unit"".
	Error 2			Monitor UM00066 and check the error code. For details of error codes, refer to ""12.2.1 ERR LED Turns ON on the Unit"".
LED Flashing	Warning	Warning occurs.	Continues the operation.	Monitor UM00065 and check the warning code. For details of warning codes, refer to ""12.2.3 ERR LED is Flashing on the Unit"".

12.1.2 Operation Mode When an Error Occurs

- When an alarm or error occurs, the unit stops the operation in the usual case. When a warning occurs, the unit continues the operation. The operation mode of the CPU unit when a unit error occurs can be changed in ""CPU Configuration"" in the tool software.
- When a warning occurs, the unit continues the operation.
- **Operation of CPU Unit when an alarm occurs (H type only)**
 - If an alarm occurs in the unit, it will give the information to the CPU as ""Unit alarm"".

12.1 Confirming Errors Using Self-diagnostic Function

- If a ""Unit alarm"" occurs, the default setting is for the CPU to stop operation.
- ""Error code (80): Unit alarm occurrence"" is displayed as a self-diagnostic error in the status display of the tool software.

■ Operation of the CPU unit when an error occurs (Common)

- If an error occurs in the unit, it will give the information to the CPU as ""Unit error"".
- If a ""Unit error"" occurs, the default setting is for the CPU to stop operation.
- ""Error code (81): Unit error"" is displayed as a self-diagnostic error in the status display of the tool software.

■ CPU configuration screen of FPWIN GR7

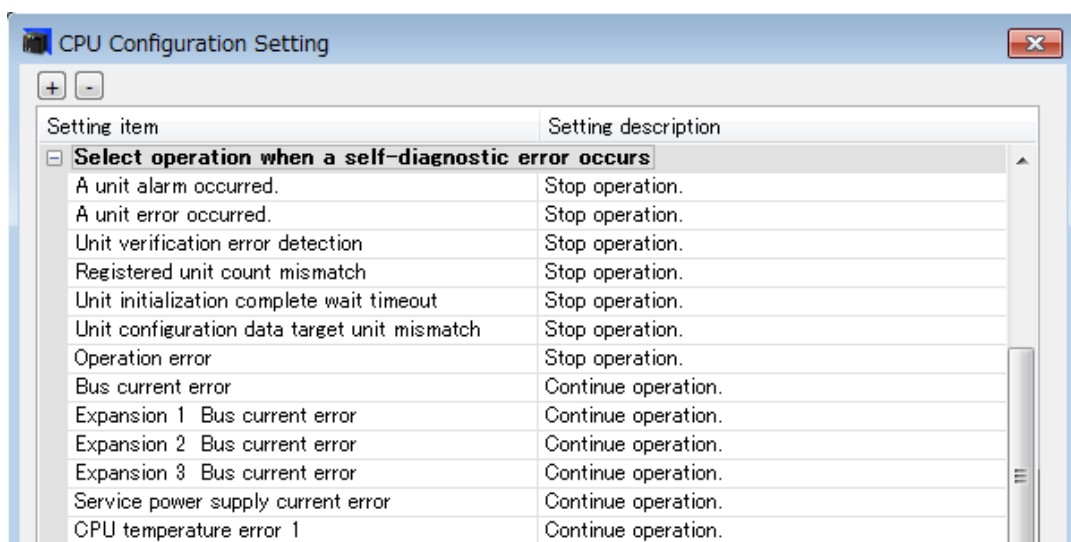

12.2 Troubleshooting

12.2.1 ERR LED Turns ON on the Unit

■ Situation

An alarm or error occurred.

■ Solution

Check the condition according to the following procedure.

1. Select **Online>Device Monitor** in FPWIN GR7.
2. Monitor the unit memory (UM00064 or UM00066) in which an error code is stored, and check the alarm/error code.
3. For code 44, monitor the unit memory (UM00207) in which a positioning error code is stored and check the detailed information. For detailed information on positioning errors, refer to the list of positioning error codes on page "P.12-5".
4. Check the appropriate way to handle for each error code, switch the mode to PROG. mode and review the settings or program. (When code 20 or 26 occurs, the unit must be rebooted.)
5. Execute the UCLR command to clear the error. In the case of alarm (code: U20) or error (code: 26), turn on the power supply again.
6. Switch the mode to RUN mode. Once the ERR.LED turns off, the error state will be cleared. If the LED does not turn off, repeat the above operation.

■ Alarm code

Code	Name	Situation	Code storage destination	Solution
U20	Unit alarm (H type only)	There is a possibility that an error occurred in the main unit.	UM00064	Reboot the unit. If the alarm still occurs, consult your Panasonic representative.

■ Error code

Code	Name	Situation	Code storage destination	Solution
U1	Double word access error	The access by one word (read, write) was executed to an area to which only the access by two words is allowed.	UM00064	Check the unit memory (UM00063) to confirm the address where the error occurred. ^(Note 1) Correct the operation unit of the instruction in the user program, so that it accesses the address where the error occurred using a two-word unit.
U26	System error	There is a possibility that an error occurred in the main unit.	UM00066	Reboot the unit. If the alarm still occurs, consult your Panasonic representative.

Code	Name	Situation	Code storage destination	Solution
U44	Positioning Error	The setting error for positioning occurs.	UM00066	Refer to "12.2.2 What to Do When Positioning Error Occurs".
U45	Unit processing error	A table number is out of the range at the time of positioning table start/positioning simultaneous start. (The table number is larger than 20.)	UM00066	Check and correct the program.

(Note 1) On the unit Ver.1.1 or later, the address where the double word access error can be confirmed in UM00063. When no error has occurred or when the error is cleared, "FFFF" is stored.

i Info.

- For details of the access units of unit memories, refer to "13.3.1 Role of Unit Memories" and "13.3.2 List of Unit Memories (AFP7MXY32DWD/ AFP7MXY32DWDH)".
- For details of the solution when the positioning error (warning code 44) occurs, refer to "12.2.2 What to Do When Positioning Error Occurs".

■ Clearing errors using user programs

- Errors can be cleared by user programs.
- Executing the dedicated instruction UCLR (error) clears errors occurred in the multi I/O unit.

Example) Program to clear errors in the multi I/O unit installed in the slot No.1



12.2.2 What to Do When Positioning Error Occurs

■ Checking the description of positioning errors

The following are detailed error codes among self-diagnostic errors when the error code 44 (positioning error) occurs. Monitor the unit memory (UM00207) where the code is stored, and confirm the solution appropriate to the code.

■ Positioning error code

Error code	Error name	Content	Operation when an error occurs and solution
H10	Limit + signal detection	The input on the plus side of the limit turned ON. ^(Note 1)	The operation stops in the limit stop time specified in the axis setting area.
H11	Limit - signal detection	The input on the minus side of the limit turned ON. ^(Note 1)	After the stop, execute the home return or JOG operation in the reverse direction.

12.2 Troubleshooting

Error code	Error name	Content	Operation when an error occurs and solution
H12	Limit signal error	Both inputs on the plus and minus sides of the limit turned on.	Correct the setting of the parameter.
H20	Axis setting error	The axis setting is incorrect.	Each control operation does not start. Correct the setting of the parameter.
H21	Limit stop deceleration time error	The set value of the limit stop deceleration time is out of the range.	
H22	Emergency stop deceleration time error	The set value of the emergency stop deceleration time is out of the range.	
H23	Startup speed error	The set value of the startup speed is out of the range.	
H24	Home return setting code error	The set value of the home return setting code is out of the range.	
H25	Home return target speed error	The set value of the home return target speed is out of the range.	
H26	Home return acceleration time error	The set value of the home return acceleration time is out of the range.	
H27	Home return deceleration time error	The set value of the home return deceleration time is out of the range.	
H28	Home return creep speed error	The set value of the home return creep speed is out of the range.	
H29	Home return direction error	The set value of the home return direction is out of the range.	
H30	JOG operation target speed error	The set value of the JOG operation target speed is out of the range.	
H31	JOG acceleration time error	The set value of the JOG acceleration time is out of the range.	
H32	JOG deceleration time error	The set value of the JOG deceleration time is out of the range.	
H41	Table setting error	The combination of tables is incorrect.	
H42	Operation pattern error	The set value of the operation pattern is incorrect.	
H43	Positioning acceleration time error	The set value of the positioning start time is out of the range.	
H44	Positioning deceleration time error	The set value of the positioning deceleration time is out of the range.	
H45	Positioning target speed error	The set value of the positioning target speed is out of the range.	
H46	Positioning movement amount error	The set value of the positioning movement amount is out of the range.	
H47	Dwell time error	The set value of the dwell time is out of the range.	
H48	J point control setting error	<ul style="list-style-type: none"> ● The setting of the J-point table is made for channels other than CH0/1. ● The J-point control is set on the interpolation axis table. 	
H60	Repeat operation dwell time setting error	The dwell time of the E table which performs repetitive operations is 0 ms.	

(Note 1) The error occurs only when the condition of the limit stop is satisfied.

■ Error code 41: Occurrence condition of table setting error

- The last table of the positioning setting tables is not the E point. (e.g. The P point, C point and J point are set continuously.)
- The control method of the J-point control table is absolute.
- The tables whose control method is absolute are set repeatedly.
- The opposite pulse output directions (forward/reverse) are set on the consecutive tables of P +E points.
- Axes to which the interpolation operation setting is made are selected for the positioning simultaneous start (MPOS).

12.2.3 ERR LED is Flashing on the Unit

■ Situation

A warning occurred. The setting content is wrong. A warning also occurs in the initial state at the time of factory shipment as the output setting is not configured.

■ Solution

Check the condition according to the following procedure.

1. Select **Online>Device Monitor** in FPWIN GR7.
2. Monitor the unit memory (UM00065) and confirm the warning code.
3. Check the appropriate way to handle for each warning code, switch the mode to PROG. mode and review the settings or program.
4. Switch the mode to RUN mode. Once the ERR.LED turns off, the warning state will be cleared. If the LED does not turn off, repeat the above operation.

■ Warning code

Code	Name	Situation	Solution
U1	Interrupt setting error	As the interrupt switch is not set, the interrupt function is not activated.	Turn on the mode setting switch no. 1 of the unit to enable the interrupt function.
U2	Output setting error	Output polarities are mixed. This error occurs when the sink output, source output, push-pull output (negative logic), or push-pull (positive logic) are mixed.	This is a warning to check if the wiring is correct. If you want to clear warnings, set "Warning annunciation" to ""Not announce"" using the tool software or program.
U3	Input voltage setting error	The input voltage is set by two points.	Set the input voltage on a program by four points.
U4	Pulse output setting error	A value exceeding the operation guarantee range (over 500,001) is set.	Monitor the unit memory (UM0015E/UM0015F) in which the pulse output flag is stored, and review the settings after confirming the detailed information.

12.2 Troubleshooting

Code	Name	Situation	Solution
U5	PWM frequency setting error	A value exceeding the settable range (over 100,001) is set.	Review the set value.

■ Cancel of warning annunciation setting

To disable warning announcement, set "Warning annunciation" to "Not announce" in the "Multi I/O Unit Setting" screen of tool software FPWIN GR7. (Available since Ver.1.1.) Or, set the bit 9 of UM00062 to 1.

Info.

- For details of the pulse output/PWM output flag (UM0015E/UM0015F), refer to "[13.4.9 Pulse Output/PWM Output Monitor Setting Area](#)".
- For details of the unit memory (UM00062), refer to "[13.4.1 Alarm/Error/Warning](#)".

13 Specifications

13.1 Specifications.....	13-2
13.1.1 General Specifications	13-2
13.1.2 Function Specifications (AFP7MXY32DWD/AFP7MXY32DWDH)	13-3
13.1.3 Positioning Function Specifications (AFP7MXY32DWDH)	13-4
13.2 Allocation of I/O Numbers	13-6
13.2.1 Input	13-6
13.2.2 Output	13-9
13.3 List of Unit Memories	13-14
13.3.1 Role of Unit Memories	13-14
13.3.2 List of Unit Memories (AFP7MXY32DWD/ AFP7MXY32DWDH) ..	13-15
13.3.3 List of Unit Memories (AFP7MXY32DWDH).....	13-17
13.4 Unit Memory Detailed Information	13-24
13.4.1 Alarm/Error/Warning	13-24
13.4.2 Input setting	13-25
13.4.3 Output Setting	13-27
13.4.4 Interrupt Setting Area	13-29
13.4.5 Counter Mode Setting Area	13-30
13.4.6 Counter Monitor Setting Area	13-31
13.4.7 Comparison Output Setting Area	13-33
13.4.8 Pulse Output / PWM Output Setting Area	13-35
13.4.9 Pulse Output/PWM Output Monitor Setting Area	13-36
13.5 Unit Memory Detailed Information (H type).....	13-39
13.5.1 Common Area	13-39
13.5.2 Axis Information Area.....	13-40
13.5.3 Axis Setting Area	13-41
13.5.4 Positioning Table Area	13-44
13.6 Dimensions	13-52

13.1 Specifications

13.1 Specifications

13.1.1 General Specifications

Item	Specifications	
Operating ambient temperature	0°C to +55°C	
Storage ambient temperature	-40°C to +70°C	
Operating ambient humidity	10 to 95% RH (at 25°C with no condensing)	
Storage ambient humidity	10 to 95% RH (at 25°C with no condensing)	
Breakdown voltage ^(Note 1)	Between input terminal and output terminals	500V AC for 1 minute
	Between input terminals and CPU power supply terminal/function earth	500V AC for 1 minute
	Between output terminals and CPU power supply terminal/function earth	500V AC for 1 minute
Insulation resistance ^(Note 2)	Between input terminal and output terminals	100 MΩ or more
	Between input terminals and CPU power supply terminal/function earth	100 MΩ or more
	Between output terminals and CPU power supply terminal/function earth	100 MΩ or more
Vibration resistance	Conforming to JISB3502 and IEC61131-2. 5 to 8.4 Hz, 3.5-mm single amplitude 8.4 to 150 Hz, acceleration of 9.8 m/s ² 10 sweeps each in X, Y, and Z directions (1 octave/min)	
Shock resistance	Conforming to JISB3502 and IEC61131-2. 147 m/s ² or more in X, Y, and Z directions three times each	
Noise resistance	1,000 V [P-P] with pulse widths of 50 ns and 1 μs (using noise simulator)	
Environment	Free from corrosive gases and excessive dust. EU Directive applicable standard	
Overvoltage category	Category II	
Pollution degree	Pollution level 2	
Internal current consumption	100 mA or less	
Weight	Approx. 100g	

(Note 1) Cutoff current: 10 mA (Default)

(Note 2) With 500 V DC megohmmeter

13.1.2 Function Specifications (AFP7MXY32DWD/AFP7MXY32DWDH)

Item		Specifications
Input/Output	No. of external inputs/outputs	Input: 16 points, Output: 16 points
	No. of occupied inputs/outputs	AFP7MXY32DWD: 64 points respectively for I/O (4 words) AFP7MXY32DWDH: 96 points respectively for I/O (6 words)
	Input time constant setting	0/0.5 μ s/1 μ s/1.5 μ s/2 μ s/4 μ s/8 μ s/16 μ s/32 μ s/64 μ s/96 μ s/128 μ s/256 μ s/2 ms/ 4 ms/8 ms ^(Note 1)
	Output polarity setting	No output, Sink output, Source output, Push-pull (negative logic), Push-pull (positive logic), Differential output ^(Note 1)
Interrupt	No. of points	Per multi I/O unit: Max. 8 points can be set in one point increments. ^(Note 2) Per CPU unit: Max. 64 programs (8 programs x 8 units)
	Mode	Non-interrupt unit, Interrupt unit (Set with the dip switches on the side of the unit.)
	Occurrence condition	Terminal input, comparison match
Counter	Number of channels	Max. 4 channels (Max. 2 channels when using the elapsed value hold function) ^(Note 2)
	Counter type	Linear counter, Ring counter
	Counting range	Signed 32-bit integer (-2,147,483,648 to +2,147,483,647)
	Input mode	<ul style="list-style-type: none"> Direction distinction input Individual input Phase input
	Max. counting speed ^{(Note 3)(Note 5)}	When input voltage is 5 V: 500 Hz (For phase input: 500 kHz) When input voltage is 12 V: 500 kHz (For phase input: 350 kHz) When input voltage is 24 V: 250 kHz (For phase input: 180 kHz)
	Min. input pulse width	0.5 μ s
	Others	Multiplication function (multiplied by 1, 2, or 4)/Elapsed value offset/preset function, Elapsed value hold function, Counter upper and lower limits setting, Overflow/underflow detection (only when setting the linear counter) Input pulse frequency measurement
Comparison output setting	Max. 8 points ^(Note 2) (4-point external input counters and 4-point pulse output counters can be arbitrarily compared using 1 point.)	
Pulse output	Number of channels	Max. 4 channels including PWM output ^(Note 2)
	Output mode	Direction distinction, Individual output, Phase output, Comparison match stop
	Output frequency	0 to 500 kHz (Settable in 1 Hz units) ^(Note 4)
	Duty	Approx. 50% (Fixed)
PWM output	Number of channels	Max. 4 channels including pulse output ^(Note 2)
	Output frequency	0 to 100 kHz (Settable in 1 Hz units) ^(Note 4)
	Duty	0 to 100% (Settable by 0.1%.)

13.1 Specifications

- (Note 1) The input mode, input time constant, and output polarity can be set by the tool software or user programs. The settable units and ranges may be different.
- (Note 2) For details of the usable combinations for each of the functions such as interrupt, counter, comparison output, pulse output, and PWM output, refer to "Unit type and available functions" in "1.2 Restrictions on Units Combination".
- (Note 3) This shows when the input pulse duty ratio is 50%.
- (Note 4) This shows when the push-pull setting is specified and the output current is 0.1 A. It varies according to the load.
- (Note 5) By default, the input time constant is set to 2 μ s. Change the setting according to the frequencies required. (The count upper limit at 2 μ s is approx. 100 kHz.)

13.1.3 Positioning Function Specifications (AFP7MXY32DWDH)

Item		Specifications
Common specifications	Number of axes controlled	Max. 4 axes
	Position setting mode	Increment, Absolute
	Output interface	Transistor open collector output, Push-pull, Line driver ^(Note 1)
	Pulse output method	Pulse/Sign, CW/CCW
	Max. output frequency	500 kHz
	Output pulse duty ratio	When using table setting mode: 50% (Fixed)
	Control unit	Pulse
Position control	Position setting range	During single axis control: -1,073,741,824 to +1,073,741,823 pulses During interpolation axis control: -8,388,608 to +8,388,607 pulses
	Speed reference range	Pulse: 1 to 500,000 Hz
	Max. operation speed	500 kHz
	Acceleration/ deceleration type	Linear acceleration/deceleration
	Acceleration time	1 to 10,000 ms (Settable by 1 ms)
	Deceleration time	1 to 10,000 ms (Settable by 1 ms)
	No. of positioning tables	20 tables for each axis (Up to 2 tables can be executed consecutively.)
	Control method (Single axis)	PTP control (E-point control, C-point control), CP control (P-point control), Speed control (J-point control) ^{(Note 2)(Note 3)}
	Control method (2-axis linear interpolation)	E-point, P-point, C-point controls, Composite speed or Long axis speed setting
Dwell time	0 to 32,767 ms (Settable by 1 ms)	
JOG operation	Speed reference range	Pulse: 1 to 500,000 Hz ^(Note 3)
	Acceleration/ deceleration type	Linear acceleration/deceleration
	Acceleration time	0 to 10,000 ms (Settable by 1 ms)
	Deceleration time	0 to 10,000 ms (Settable by 1 ms)

Item		Specifications
Home Return	Speed reference range	Pulse: 1 to 500,000 Hz
	Acceleration/ deceleration type	Linear acceleration/deceleration
	Acceleration time	1 to 10,000 ms (Settable by 1 ms)
	Deceleration time	1 to 10,000 ms (Settable by 1 ms)
	Return method	DOG methods (3 types), Home position method, Data set method
Stop function	Deceleration stop	Performs deceleration stop in the deceleration time of a running operation for each axis.
	Emergency stop	Stops in a deceleration time specified for the emergency stop for each axis. ^(Note 4)
	Limit stop	Stops in a deceleration time specified for the limit input for each axis. ^(Note 4)
	System stop	Stops all axes immediately.

(Note 1) The number of axes is reduced when setting Line driver.

(Note 2) J-point control is executable only for the two axes of CH0 and CH1.

(Note 3) When performing J-point control or JOG operation, the speed can be changed after startup.

(Note 4) This is a deceleration time from 500 kHz.

13.2 Allocation of I/O Numbers

13.2 Allocation of I/O Numbers

13.2.1 Input

■ External terminals

Terminal number	I/O no.	Functions						
		Interrupt input	Counter	Counter elapsed value hold	Comparison	Pulse output	PWM output	Positioning (H type)
A1	X0	-	CH0 IN-A		-	-	-	CH0 Z
A2	X1	-	CH0 IN-B		-	-	-	CH0 DOG
								CH0 JPOS
A3	X2	-	CH0 RST		-	-	-	CH0 LMT+
A4	X3	-	CH0 MASK		-	-	-	CH0 LMT-
A5	X4	-	CH1 IN-A		-	-	-	CH1 Z
A6	X5	-	CH1 IN-B		-	-	-	CH1 DOG
								CH1 JPOS
A7	X6	-	CH1 RST		-	-	-	CH1 LMT+
A8	X7	-	CH1 MASK		-	-	-	CH1 LMT-
B1	X8	INT0	CH2 IN-A	CH0 TRG	-	-	-	CH2 Z
B2	X9	INT1	CH2 IN-B	-	-	-	-	CH2 DOG
B3	XA	INT2	CH2 RST	-	-	-	-	CH2 LMT+
B4	XB	INT3	CH2 MASK	-	-	-	-	CH2 LMT-
B5	XC	INT4	CH3 IN-A	CH1 TRG	-	-	-	CH3 Z
B6	XD	INT5	CH3 IN-B	-	-	-	-	CH3 DOG
B7	XE	INT6	CH3 RST	-	-	-	-	CH3 LMT+
B8	XF	INT7	CH3 MASK	-	-	-	-	CH3 LMT-

(Note 1) The I/O numbers actually allocated are the numbers based on the starting word number allocated to the unit.

Example) When the starting word number of the unit is "10", the interrupt input corresponding to INT0 is X108.

(Note 2) Any one of functions allocated to the same I/O number in the table above can be used. Functions to be allocated are specified in the "Configuration" dialog box of the tool software. The inputs that are not allocated to any functions can be used as general inputs.

(Note 3) The functions of each signal are as follows.

Signal name	Description
INTx	This is the interrupt signal of external inputs.
CHx IN-A	This is the A phase (or CW/pulse) input signal for the counter.
CHx IN-B	This is the B phase (or CW/pulse) input signal for the counter.
CHx RST	This is the reset signal for the counter.

Signal name	Description
CHx MASK	This is the mask signal for the counter. Counting is disabled when this signal is on.
CHx TRG	This is the trigger signal that is used when using the elapsed value hold function for count values. The rising and trailing edges can be switched by the output signal CHx TRG LOG.
CHx Z	This is the home signal for positioning.
CHx DOG	This is the near home signal for positioning.
CHx JPOS	This is the J-point control positioning start signal for positioning.
CHx LMT +	This is the limit + signal for positioning.
CHx LMT -	This is the limit - signal for positioning.

■ Internal I/O

Terminal number	I/O no.	Functions						
		Interrupt input	Counter	Counter elapsed value hold	Comparison	Pulse output	PWM output	Positioning (H type)
-	X10	-	-	-	CMP0	-	-	-
-	X11	-	-	-	CMP1	-	-	-
-	X12	-	-	-	CMP2	-	-	-
-	X13	-	-	-	CMP3	-	-	-
-	X14	-	-	-	CMP4	-	-	-
-	X15	-	-	-	CMP5	-	-	-
-	X16	-	-	-	CMP6	-	-	-
-	X17	-	-	-	CMP7	-	-	-
-	X18	-	-	-	-	PLS0 A	PWM0	-
-	X19	-	-	-	-	PLS0 B	-	-
-	X1A	-	-	-	-	PLS1 A	PWM1	-
-	X1B	-	-	-	-	PLS1 B	-	-
-	X1C	-	-	-	-	PLS2 A	PWM2	-
-	X1D	-	-	-	-	PLS2 B	-	-
-	X1E	-	-	-	-	PLS3 A	PWM3	-
-	X1F	-	-	-	-	PLS3 B	-	-
-	X20	-	CH0 UDF	-	-	-	-	-
-	X21	-	CH1 UDF	-	-	-	-	-
-	X22	-	CH2 UDF	-	-	-	-	-
-	X23	-	CH3 UDF	-	-	-	-	-
-	X24	-	CH0 OVF	-	-	-	-	-

13.2 Allocation of I/O Numbers

Terminal number	I/O no.	Functions						
		Interrupt input	Counter	Counter elapsed value hold	Comparison	Pulse output	PWM output	Positioning (H type)
-	X25	-	CH1 OVF	-	-	-	-	-
-	X26	-	CH2 OVF	-	-	-	-	-
-	X27	-	CH3 OVF	-	-	-	-	-
-	X28-X2F	-	-	-	-	-	-	-
-	X30	-	-	-	-	-	-	CH0 BUSY
-	X31	-	-	-	-	-	-	CH1 BUSY
-	X32	-	-	-	-	-	-	CH2 BUSY
-	X33	-	-	-	-	-	-	CH3 BUSY
-	X34	-	-	-	-	-	-	CH0 FIN
-	X35	-	-	-	-	-	-	CH1 FIN
-	X36	-	-	-	-	-	-	CH2 FIN
-	X37	-	-	-	-	-	-	CH3 FIN
-	X38	-	-	-	-	-	-	CH0 HFIN
-	X39	-	-	-	-	-	-	CH1 HFIN
-	X3A	-	-	-	-	-	-	CH2 HFIN
-	X3B	-	-	-	-	-	-	CH3 HFIN
-	X3C-X3F	-	-	-	-	-	-	-
-	X40-X5F (H type only)	-	-	-	-	-	-	-

(Note 1) The I/O numbers actually allocated are the numbers based on the starting word number allocated to the unit.

Example) When the starting word number of the unit is "10", the interrupt input corresponding to INTO is X108.

(Note 2) Any one of functions allocated to the same I/O number in the table above can be used. Functions to be allocated are specified in the "Configuration" dialog box of the tool software. The inputs that are not allocated to any functions can be used as general inputs.

(Note 3) The I/O numbers X10 to X27F are contacts for monitoring on user programs.

(Note 4) The functions of each signal are as follows.

Signal name	Description
CHx UDF	This is the contact for monitoring the underflow flag for the counter.
CMPx	This is the contact for monitoring the comparison output. This is switched between the on and off states by the setting.
PLSx A	This is the contact for monitoring the A-phase output of pulse output.
PLSx B	This is the contact for monitoring the B-phase output of pulse output.
PWMx	This is the contact for monitoring the PWM output.

Signal name	Description
CHx BUSY	This is the contact for monitoring the busy flag for positioning.
CHx FIN	This is the contact for monitoring the operation done flag for positioning.
CHx HFIN	This is the contact for monitoring the home return done flag for positioning.

13.2.2 Output

■ External terminals

Terminal number	I/O no.	Functions						
		Interrupt input	Counter	Counter elapsed value hold mode	Comparison	Pulse output	PWM output	Positioning (H type)
A11	Y0	-	-	-	CMP0	-	-	-
A12	Y1	-	-	-	CMP1	-	-	-
A13	Y2	-	-	-	CMP2	-	-	-
A14	Y3	-	-	-	CMP3	-	-	-
A15	Y4	-	-	-	CMP4	-	-	CH0 CLR
A16	Y5	-	-	-	CMP5	-	-	CH1 CLR
A17	Y6	-	-	-	CMP6	-	-	CH2 CLR
A18	Y7	-	-	-	CMP7	-	-	CH3 CLR
B11	Y8	-	-	-	-	PLS0 A	PWM0	PLS0 A
B12	Y9	-	-	-	-	PLS0 B	-	PLS0 B
B13	YA	-	-	-	-	PLS1 A	PWM1	PLS1 A
B14	YB	-	-	-	-	PLS1 B	-	PLS1 B
B15	YC	-	-	-	-	PLS2 A	PWM2	PLS2 A
B16	YD	-	-	-	-	PLS2 B	-	PLS2 B
B17	YE	-	-	-	-	PLS3 A	PWM3	PLS3 A
B18	YF	-	-	-	-	PLS3 B	-	PLS3 B

(Note 1) The I/O numbers in the table indicates offset addresses. The I/O numbers actually allocated are based on the starting word number allocated to the unit.

Example) When the starting word number for the unit is ""10"", the reset input for the counter CH0 is Y110.

(Note 2) Any one of functions allocated to the same I/O number in the table above can be used. Functions to be allocated are specified in the "Configuration" dialog box of the tool software. The outputs that are not allocated to any functions can be used as general outputs.

(Note 3) The comparison contacts CMP0 to CMP7, pulse outputs PLS0 to PLS3, and PWM outputs PWM0 to PWM3 are signals which are directly output to I/O connectors. They are not related to the I/O numbers Y0 to YF. The states of these signals can be monitored by the inputs X10 to X1F. (Unlike general outputs, they are not reflected in the outputs Y0 to YF.)

(Note 4) The functions of each signal are as follows.

13.2 Allocation of I/O Numbers

Signal name	Description
CMPx	This is the comparison match signal.
PLSx A	This is the A phase (or CW/pulse) output signal for pulse output
PLSx B	This is the B phase (or CCW/direction) output signal for pulse output
PWMx	This is the PWM output signal for pulse output.
CHx CLR	This is the deviation counter clear signal for positioning.
PLSx A	This is the CW (or pulse) output signal for positioning.
PLSx B	This is the CCW (or sign) output signal for positioning.

■ Internal I/O

Terminal number	I/O no.	Functions						
		Interrupt input	Counter	Counter elapsed value hold mode	Comparison	Pulse output	PWM output	Positioning (H type)
-	Y10	-	CH0 SOFT RST		-	-	-	-
-	Y11	-	CH0 MASK		-	-	-	-
-	Y12	-	CH1 RST		-	-	-	-
-	Y13	-	CH1 MASK		-	-	-	-
-	Y14	-	CH2 SOFT RST	CH0 LATCH EN	-	-	-	-
-	Y15	-	CH2 SOFT MASK	CH0 TRG LOG	-	-	-	-
-	Y16	-	CH3 SOFT RST	CH1 LATCH EN	-	-	-	-
-	Y17	-	CH3 SOFT MASK	CH1 TRG LOG	-	-	-	-
-	Y18	-	-	-	-	PLS0 EN	PWM0 EN	-
-	Y19	-	-	-	-	PLS1 EN	PWM1 EN	-
-	Y1A	-	-	-	-	PLS2 EN	PWM2 EN	-
-	Y1B	-	-	-	-	PLS3 EN	PWM3 EN	-
-	Y1C	-	-	-	-	PLS0 ST	PWM0 ST	-
-	Y1D	-	-	-	-	PLS1 ST	PWM1 ST	-
-	Y1E	-	-	-	-	PLS2 ST	PWM2 ST	-
-	Y1F	-	-	-	-	PLS3 ST	PWM3 ST	-
-	Y20	-	CH0 UDF CLR		-	-	-	-

13.2 Allocation of I/O Numbers

Terminal number	I/O no.	Functions						Positioning (H type)
		Interrupt input	Counter	Counter elapsed value hold mode	Comparison	Pulse output	PWM output	
-	Y21	-	CH1 UDF CLR		-	-	-	-
-	Y22	-	CH2 UDF CLR	-	-	-	-	-
-	Y23	-	CH3 UDF CLR	-	-	-	-	-
-	Y24	-	CH0 OVF CLR		-	-	-	-
-	Y25	-	CH1 OVF CLR		-	-	-	-
-	Y26	-	CH2 OVF CLR	-	-	-	-	-
-	Y27	-	CH3 OVF CLR	-	-	-	-	-
-	Y28	-	-	-	-	PLS0 DIR	-	-
-	Y29	-	-	-	-	PLS1 DIR	-	-
-	Y2A	-	-	-	-	PLS2 DIR	-	-
-	Y2B	-	-	-	-	PLS3 DIR	-	-
-	Y2C	-	-	-	-	PLS0 CNT RST		-
-	Y2D	-	-	-	-	PLS1 CNT RST		-
-	Y2E	-	-	-	-	PLS2 CNT RST		-
-	Y2F	-	-	-	-	PLS3 CNT RST		-
-	Y30	-	-	-	-	-	-	CH0 POS
-	Y31	-	-	-	-	-	-	CH1 POS
-	Y32	-	-	-	-	-	-	CH2 POS
-	Y33	-	-	-	-	-	-	CH3 POS
-	Y34	-	-	-	-	-	-	MPOS
-	Y35	-	-	-	-	-	-	-
-	Y36	-	-	-	-	-	-	-
-	Y37	-	-	-	-	-	-	-
-	Y38	-	-	-	-	-	-	CH0 HOME
-	Y39	-	-	-	-	-	-	CH1 HOME
-	Y3A	-	-	-	-	-	-	CH2 HOME
-	Y3B	-	-	-	-	-	-	CH3 HOME
-	Y3C	-	-	-	-	-	-	CH0 JOG+
-	Y3D	-	-	-	-	-	-	CH1 JOG+
-	Y3E	-	-	-	-	-	-	CH2 JOG+
-	Y3F	-	-	-	-	-	-	CH3 JOG+
-	Y40	-	-	-	-	-	-	CH0 JOG
-	Y41	-	-	-	-	-	-	CH1 JOG

13.2 Allocation of I/O Numbers

Terminal number	I/O no.	Functions						
		Interrupt input	Counter	Counter elapsed value hold mode	Comparison	Pulse output	PWM output	Positioning (H type)
-	Y42	-	-	-	-	-	-	CH2 JOG
-	Y43	-	-	-	-	-	-	CH3 JOG
-	Y44	-	-	-	-	-	-	SYS STP
-	Y45-Y47	-	-	-	-	-	-	-
-	Y48	-	-	-	-	-	-	CH0 EMG STP
-	Y49	-	-	-	-	-	-	CH1 EMG STP
-	Y4A	-	-	-	-	-	-	CH2 EMG STP
-	Y4B	-	-	-	-	-	-	CH3 EMG STP
-	Y4C	-	-	-	-	-	-	CH0 DEC STP
-	Y4D	-	-	-	-	-	-	CH1 DEC STP
-	Y4E	-	-	-	-	-	-	CH2 DEC STP
-	Y4F	-	-	-	-	-	-	CH3 DEC STP
-	Y50	-	-	-	-	-	-	CH0 JPOS
-	Y51	-	-	-	-	-	-	CH1 JPOS
-	Y52	-	-	-	-	-	-	CH0 DOG
-	Y53	-	-	-	-	-	-	CH1 DOG
-	Y54	-	-	-	-	-	-	CH0 JPOS SP
-	Y55	-	-	-	-	-	-	CH1 JPOS SP
-	Y56	-	-	-	-	-	-	ECLR
-	Y57	-	-	-	-	-	-	-
-	Y58-Y5F	-	-	-	-	-	-	-

(Note 1) The I/O numbers in the table indicates offset addresses. The I/O numbers actually allocated are based on the starting word number allocated to the unit.

Example) When the starting word number for the unit is "10", the reset input for the counter CH0 is Y110.

(Note 2) Any one of functions allocated to the same I/O number in the table above can be used. Functions to be allocated are specified in the "Configuration" dialog box of the tool software. The outputs that are not allocated to any functions can be used as general outputs.

(Note 3) The I/O numbers Y10 to Y2F are contacts for controlling each function in user programs.

(Note 4) The comparison contacts CMP0 to CMP7, pulse outputs PLS0 to PLS3, and PWM outputs PWM0 to PWM3 are signals which are directly output to I/O connectors. They are not related to the I/O numbers Y0 to YF. The states of these signals can be monitored by the inputs X10 to X1F. (Unlike general outputs, they are not reflected in the outputs Y0 to YF.)

(Note 5) The functions of each signal are as follows.

Signal name	Description
CHx SOFT RST	This is the reset signal for the counter. The counter is reset to its preset value.

Signal name	Description
CHx SOFT MASK	This is the mask signal for the counter. Counting is disabled when this signal is on.
CHx LATCH EN	This is the enable signal for the elapsed value hold function.
CHx TRG LOG	This switches the trigger input logic when using the elapsed value hold function.
CHx UDF CLR	This is the underflow clear signal for the counter. It clears the underflow flag.
CHx OVF CLR	This is the overflow clear signal for the counter. It clears the overflow flag.
PLSx EN	This is the enable signal for the pulse output. The pulse output can be performed when this signal is on.
PLSx ST	This is the start signal for the pulse output.. This is also used for changing frequencies.
PLSx DIR	This is the sign signal for the pulse output.
PLSx CNT RST	This is the signal for resetting the elapsed value of pulse output counter.
PWMx EN	This is the enable signal for the PWM output. The PWM output can be performed when this signal is on.
PWMx ST	This is the start signal for the PWM output. This is also used for changing the frequency and duty.
CHx POS	This is the table start signal for positioning.
MPOS	This is the simultaneous start signal for positioning.
CHx HOME	This is the home return start signal for positioning.
CHx JOG +	This is the JOG operation (forward) start signal for positioning.
CHx JOG -	This is the JOG operation (reverse) start signal for positioning.
SYS STP	This is the system stop signal for positioning.
CHx EMG STP	This is the emergency stop signal for positioning.
CHx DEC STP	This is the deceleration stop signal for positioning.
CHx J POS	This is the J-point control positioning start signal for positioning.
CHx DOG	This is the near home signal for positioning.
CHx J POS SP	This is the J-point control speed change signal for positioning.
ECLR	This is the error clear request signal for positioning.

13.3 List of Unit Memories

13.3 List of Unit Memories

13.3.1 Role of Unit Memories

Unit memories are arithmetic memories to access the monitor area and configuration information area of the unit.

■ Accessing unit memories

The symbols described in the unit memory list below indicate the following content.

Unit	It indicates the unit in the case of the access (read, write) using user programs. 1W: 1 word, 2W: 2 words
R	It indicates the area that can be read using user programs.
W	It indicates the area that can be written using user programs.

■ Reading from unit memories (UM)

The areas which are shown as enabled in the ""R"" column in the following table can be read with user programs using transfer instructions or arithmetic instructions. The operand of an instruction is specified by the combination of the slot number where the slot is installed and a unit memory number (UM).

Example) Program to read the elapsed value area (UM00110) of the counter CH0 of the multi I/O unit installed in the slot number 1 (S1) to an arbitrary data register (DT100)

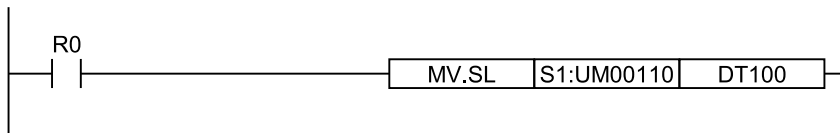

■ Writing to unit memories (UM)

- When the mode changes from PROG. to RUN, the configuration information set by the tool software will be stored.
- The areas which are shown as enabled in the ""W"" column in the following table can be read with user programs using transfer instructions or arithmetic instructions. The operand of an instruction is specified by the combination of the slot number where the slot is installed and a unit memory number (UM).
- Be sure not to execute writing in the reserved areas for the system.

Example) Program to change the elapsed value area (UM00110) of the counter CH0 for external input to 100000

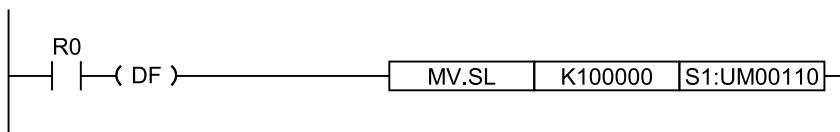



- Be sure not to execute reading or writing in the reserved areas for the system.
- An error will occur if the access by one word (read, write) is executed to an area to which only the access by two words is allowed.

i Info.

- Programs for reading and writing values from unit memories can be easily created by using the ""Template Function"" of FPWIN GR7. Refer to "11.1 Creating of Ladder Programs Using Templates".

13.3.2 List of Unit Memories (AFP7MXY32DWD/ AFP7MXY32DWDH)

A: Available, -: Not available

Item	Unit memory number (Hex.)	Content	Access unit	R	W	
-	UM 00000-UM 00061	(Reserved for system)	-	-	-	
Alarm/Error/Warning	UM 00062	Error alarm setting	1 W	A	A	
	UM 00063	Double word access error occurrence address	1 W	A	-	
	UM 00064	Unit error code 1	1 W	A	-	
	UM 00065	Unit warning code	1 W	A	-	
	UM 00066	Unit error code 2	1 W	A	-	
-	UM 00067-UM 0006F	(Reserved for system)	—	-	-	
Input/Output	UM 00070-UM 00071	Input time constant voltage setting (High resolution)	1 W	A	A	
-	UM 00072	(Reserved for system)	-	-	-	
-	UM 00073-UM 000FF	(Reserved for system)	-	-	-	
Input/Output	UM 00100-UM 00101	Input voltage / Input time constant voltage setting	1 W	A	A	
	UM 00102-UM 00103	(Reserved for system)	-	-	-	
	UM 00104	Output polarity setting	1 W	A	A	
	UM 00105	Output contact terminal interrupt setting	1 W	A	A	
	UM 00106-UM 00107	(Reserved for system)	-	-	-	
Interrupt	UM 00108-UM 00109	Interrupt setting	1 W	A	A	
	UM 0010A-UM 0010B	(Reserved for system)	-	-	-	
High-speed counter	UM 0010C-UM 0010D	Counter mode setting	1 W	A	A	
	UM 0010E-UM 0010F	(Reserved for system)	-	-	-	
	UM 00110-UM 00111	Counter elapsed value	CH0	2 W	A	A
	UM 00112-UM 00113	Counter elapsed value	CH1	2 W	A	A
	UM 00114-UM 00115	Counter elapsed value	CH2	2 W	A	A
Counter hold value ^(Note 1)		CH0				

13.3 List of Unit Memories

Item	Unit memory number (Hex.)	Content	Access unit	R	W	
	UM 00116-UM 00117	Counter elapsed value	CH3	2 W	A	A
		Counter hold value ^(Note 1)	CH1			
	UM 00118-UM 00119	Counter preset value	CH0	2 W	A	A
	UM 0011A-UM 0011B		CH1	2 W	A	A
	UM 0011C-UM 0011D		CH2	2 W	A	A
	UM 0011E-UM 0011F		CH3	2 W	A	A
	UM 00120-UM 00121	Counter lower limit value	CH0	2 W	A	A
	UM 00122-UM 00123		CH1	2 W	A	A
	UM 00124-UM 00125		CH2	2 W	A	A
	UM 00126-UM 00127		CH3	2 W	A	A
	UM 00128-UM 00129	Counter upper limit value	CH0	2 W	A	A
	UM 0012A-UM 0012B		CH1	2 W	A	A
	UM 0012C-UM 0012D		CH2	2 W	A	A
	UM 0012E-UM 0012F		CH3	2 W	A	A
	UM 00130-UM 00131	Counter input frequency measurement value	CH0	2 W	A	A
	UM 00132-UM 00133		CH1	2 W	A	A
	UM 00134-UM 00135		CH2	2 W	A	A
	UM 00136-UM 00137		CH3	2 W	A	A
UM 00138-UM 0013F	(Reserved for system)		-	-	-	
Comparison	UM 00140	Corresponding counter setting (CMP0-CMP3)		1 W	A	A
	UM 00141	Corresponding counter setting (CMP4-CMP7)		1 W	A	A
	UM 00142	Comparison function validation setting (CMP0-CMP3)		1 W	A	A
	UM 00143	Comparison function validation setting (CMP4-CMP7)		1 W	A	A
	UM 00144-UM 00145	Comparison output setting value	CMP0	2 W	A	A
	UM 00146-UM 00147		CMP1	2 W	A	A
	UM 00148-UM 00149		CMP2	2 W	A	A
	UM 0014A-UM 0014B		CMP3	2 W	A	A
	UM 0014C-UM 0014D		CMP4	2 W	A	A
	UM 0014E-UM 0014F		CMP5	2 W	A	A
	UM 00150-UM 00151		CMP6	2 W	A	A
	UM 00152-UM 00153		CMP7	2 W	A	A
UM 00154-UM 0015B	(Reserved for system)		-	-	-	
Pulse output PWM output	UM 0015C	PLS/PWM function setting		1 W	A	A
	UM 0015D	PLS/PWM counter function setting		1 W	A	A
	UM 0015E	PLS/PWM flag (CH0/CH1)		1 W	A	-

13.3 List of Unit Memories

Item	Unit memory number (Hex.)	Content	Access unit	R	W
	UM 0015F	PLS/PWM flag (CH2/CH3)	1 W	A	-
	UM 00160-UM 00161	PLS/PWM frequency	CH0	2 W	A A
	UM 00162-UM 00163		CH1	2 W	A A
	UM 00164-UM 00165		CH2	2 W	A A
	UM 00166-UM 00167		CH3	2 W	A A
	UM 00168-UM 00169		PWM duty	CH0	2 W
	UM 0016A-UM 0016B	CH1		2 W	A A
	UM 0016C-UM 0016D	CH2		2 W	A A
	UM 0016E-UM 0016F	CH3		2 W	A A
	UM 00170-UM 00171	PLS/PWM counter elapsed value	CH0	2 W	A A
	UM 00172-UM 00173		CH1	2 W	A A
	UM 00174-UM 00175		CH2	2 W	A A
	UM 00176-UM 00177		CH3	2 W	A A
	UM 00178-UM 00179	PLS/PWM counter lower limit value	CH0	2 W	A A
	UM 0017A-UM 0017B		CH1	2 W	A A
	UM 0017C-UM 0017D		CH2	2 W	A A
	UM 0017E-UM 0017F		CH3	2 W	A A
	UM 00180-UM 00181	PLS/PWM counter upper limit value	CH0	2 W	A A
	UM 00182-UM 00183		CH1	2 W	A A
	UM 00184-UM 00185		CH2	2 W	A A
	UM 00186-UM 00187		CH3	2 W	A A
	UM 00188-UM 0019F	(Reserved for system)	-	-	-

(Note 1) In counter elapsed value hold mode

13.3.3 List of Unit Memories (AFP7MXY32DWDH)

The following is the list of unit memories for the positioning function.

A: Available, -: Not available

Unit memory number (Hex.)	Content	Access unit	R	W
UM 00200	Axis setting	1 W	A	A
UM 00201	Positioning repeat count	CH0	1 W	A A
UM 00202		CH1	1 W	A A
UM 00203		CH2	1 W	A A
UM 00204		CH3	1 W	A A
UM 00205-UM 00206	(Reserved for system)	-	-	-

13.3 List of Unit Memories

Unit memory number (Hex.)	Content	Access unit	R	W	
UM 00207	Positioning error code	1 W	A	-	
UM 00208	(Reserved for system)	-	-	-	
UM 00209	Starting table number	CH0	1 W	A	A
UM 0020A		CH1	1 W	A	A
UM 0020B		CH2	1 W	A	A
UM 0020C		CH3	1 W	A	A
UM 0020D-UM 0020F	(Reserved for system)	-	-	-	
UM 00210	Simultaneous starting table number	CH0	1 W	A	A
UM 00211		CH1	1 W	A	A
UM 00212		CH2	1 W	A	A
UM 00213		CH3	1 W	A	A
UM 00214-UM 0021D	(Reserved for system)	-	-	-	
UM 0021E	Active or execution done table	CH0	1 W	A	-
UM 0021F	Repeat count current value		1 W	A	-
UM 00220-UM 00221	Elapsed value (Current value coordinate)		2 W	A	A
UM 00222-UM 00227	(Reserved for system)		-	-	-
UM 00228	Active or execution done table	CH1	1 W	A	-
UM 00229	Repeat count current value		1 W	A	-
UM 0022A-UM 0022B	Elapsed value (Current value coordinate)		2 W	A	A
UM 0022C-UM 00231	(Reserved for system)		-	-	-
UM 00232	Active or execution done table	CH2	1 W	A	-
UM 00233	Repeat count current value		1 W	A	-
UM 00234-UM 00235	Elapsed value (Current value coordinate)		2 W	A	A
UM 00236-UM 0023B	(Reserved for system)		-	-	-
UM 0023C	Active or execution done table	CH3	1 W	A	-
UM 0023D	Repeat count current value		1 W	A	-
UM 0023E-UM 0023F	Elapsed value (Current value coordinate)		2 W	A	A
UM 00240-UM 00245	(Reserved for system)		-	-	-
UM 00246-UM 00263	(Reserved for system)	-	-	-	
UM 00264	Pulse output control code	CH0	1 W	A	A
UM 00265-UM 00266	Startup Speed		2 W	A	A
UM 00267	Home return method		1 W	A	A
UM 00268	Home return direction		1 W	A	A
UM 00269	Home return acceleration time		1 W	A	A
UM 0026A	Home return deceleration time		1 W	A	A
UM 0026B-UM 0026C	Home return target speed		2 W	A	A
UM 0026D-UM 0026E	Home return creep speed		2 W	A	A

13.3 List of Unit Memories

Unit memory number (Hex.)	Content		Access unit	R	W
UM 0026F	Deviation counter clear time		1 W	A	A
UM 00270-UM 00271	Coordinate origin		2 W	A	A
UM 00272	JOG acceleration time		1 W	A	A
UM 00273	JOG deceleration time		1 W	A	A
UM 00274-UM 00275	JOG operation target speed		2 W	A	A
UM 00276-UM 00277	J point change target speed		2 W	A	A
UM 00278	Emergency stop deceleration time		1 W	A	A
UM 00279	Limit stop deceleration time		1 W	A	A
UM 0027A-UM 00281	(Reserved for system)		-	-	-
UM 00282	Pulse output control code		1 W	A	A
UM 00283-UM 00284	Startup Speed		2 W	A	A
UM 00285	Home return method		1 W	A	A
UM 00286	Home return direction		1 W	A	A
UM 00287	Home return acceleration time		1 W	A	A
UM 00288	Home return deceleration time		1 W	A	A
UM 00289-UM 0028A	Home return target speed		2 W	A	A
UM 0028B-UM 0028C	Home return creep speed		2 W	A	A
UM 0028D	Deviation counter clear time	CH1	1 W	A	A
UM 0028E-UM 0028F	Coordinate origin		2 W	A	A
UM 00290	JOG acceleration time		1 W	A	A
UM 00291	JOG deceleration time		1 W	A	A
UM 00292-UM 00293	JOG operation target speed		2 W	A	A
UM 00294-UM 00295	J point change target speed		2 W	A	A
UM 00296	Emergency stop deceleration time		1 W	A	A
UM 00297	Limit stop deceleration time		1 W	A	A
UM 00298-UM 0029F	(Reserved for system)		-	-	-
UM 002A0	Pulse output control code		1 W	A	A
UM 002A1-UM 002A2	Startup Speed		2 W	A	A
UM 002A3	Home return method		1 W	A	A
UM 002A4	Home return direction		1 W	A	A
UM 002A5	Home return acceleration time		1 W	A	A
UM 002A6	Home return deceleration time	CH2	1 W	A	A
UM 002A7-UM 002A8	Home return target speed		2 W	A	A
UM 002A9-UM 002AA	Home return creep speed		2 W	A	A
UM 002AB	Deviation counter clear time		1 W	A	A
UM 002AC-UM 002AD	Coordinate origin		2 W	A	A
UM 002AE	JOG acceleration time		1 W	A	A

13.3 List of Unit Memories

Unit memory number (Hex.)	Content		Access unit	R	W
UM 002AF	JOG deceleration time		1 W	A	A
UM 002B0-UM 002B1	JOG operation target speed		2 W	A	A
UM 002B2-UM 002B3	J point change target speed		2 W	A	A
UM 002B4	Emergency stop deceleration time		1 W	A	A
UM 002B5	Limit stop deceleration time		1 W	A	A
UM 002B6-UM 002BD	(Reserved for system)		-	-	-
UM 002BE	Pulse output control code		1 W	A	A
UM 002BF-UM 002C0	Startup Speed		2 W	A	A
UM 002C1	Home return method		1 W	A	A
UM 002C2	Home return direction		1 W	A	A
UM 002C3	Home return acceleration time		1 W	A	A
UM 002C4	Home return deceleration time		1 W	A	A
UM 002C5-UM 002C6	Home return target speed		2 W	A	A
UM 002C7-UM 002C8	Home return creep speed		2 W	A	A
UM 002C9	Deviation counter clear time	CH3	1 W	A	A
UM 002CA-UM 002CB	Coordinate origin		2 W	A	A
UM 002CC	JOG acceleration time		1 W	A	A
UM 002CD	JOG deceleration time		1 W	A	A
UM 002CE-UM 002CF	JOG operation target speed		2 W	A	A
UM 002D0-UM 002D1	J point change target speed		2 W	A	A
UM 002D2	Emergency stop deceleration time		1 W	A	A
UM 002D3	Limit stop deceleration time		1 W	A	A
UM 002D4-UM 002DB	(Reserved for system)		-	-	-
UM 002DC-UM 0032B	(Reserved for system)		-	-	-
UM 0032C	Control code	Table no. 1	1 W	A	A
UM 0032D	Control pattern		1 W	A	A
UM 0032E	Positioning acceleration time		1 W	A	A
UM 0032F	Positioning deceleration time		1 W	A	A
UM 00330-UM 00331	Positioning target speed		2 W	A	A
UM 00332-UM 00333	Positioning movement amount		2 W	A	A
UM 00334	Dwell time		1 W	A	A
UM 00335	(Reserved for system)		-	-	-
UM 00336-UM 0033F	The parameters (10 words) which are the same configuration as those for table no. 1 are allocated.	Table no. 2	Same as Table No. 1.		
UM 00340-UM 00349		Table no. 3			
UM 0034A-UM 00353		Table no. 4			
UM 00354-UM 0035D		Table no. 5			
UM 0035E-UM 00367		Table no. 6			

13.3 List of Unit Memories

Unit memory number (Hex.)	Content	Access unit	R	W	
UM 00368-UM 00371					
UM 00372-UM 0037B					Table no. 7
UM 0037C-UM 00385					Table no. 8
UM 00386-UM 0038F					Table no. 9
UM 00390-UM 00399					Table no. 10
UM 0039A-UM 003A3					Table no. 11
UM 003A4-UM 003AD					Table no. 12
UM 003AE-UM 003B7					Table no. 13
UM 003B8-UM 003C1					Table no. 14
UM 003C2-UM 003CB					Table no. 15
UM 003CC-UM 003D5					Table no. 16
UM 003D6-UM 003DF					Table no. 17
UM 003E0-UM 003E9					Table no. 18
UM 003EA-UM 003F3					Table no. 19
UM 003F4-UM 00425	(Reserved for system)	-	-	-	
UM 00426	Control code	Table no. 1	1 W	A	A
UM 00427	Control pattern		1 W	A	A
UM 00428	Positioning acceleration time		1 W	A	A
UM 00429	Positioning deceleration time		1 W	A	A
UM 0042A-UM 0042B	Positioning target speed		2 W	A	A
UM 0042C-UM 0042D	Positioning movement amount		2 W	A	A
UM 0042E	Dwell time		1 W	A	A
UM 0042F	(Reserved for system)		-	-	-
UM 00430-UM 00439	The parameters (10 words) which are the same configuration as those for table no. 1 are allocated.	CH1			
UM 0043A-UM 00443					Table no. 2
UM 00444-UM 0044D					Table no. 3
UM 0044E-UM 00457					Table no. 4
UM 00458-UM 00461					Table no. 5
UM 00462-UM 0046B					Table no. 6
UM 0046C-UM 00475					Table no. 7
UM 00476-UM 0047F					Table no. 8
UM 00480-UM 00489					Table no. 9
UM 0048A-UM 00493					Table no. 10
UM 00494-UM 0049D					Table no. 11
UM 0049E-UM 004A7					Table no. 12
UM 004AB-UM 004B1					Table no. 13
UM 004B2-UM 004BB					Table no. 14
	Table no. 15	Same as Table No. 1.			

13.3 List of Unit Memories

Unit memory number (Hex.)	Content	Access unit	R	W	
UM 004BC-UM 004C5					
UM 004C6-UM 004CF					Table no. 16
UM 004D0-UM 004D9					Table no. 17
UM 004DA-UM 004E3					Table no. 18
UM 004E4-UM 004ED					Table no. 19
UM 004EE-UM 0051F	(Reserved for system)		-	-	
UM 00520	Control code	Table no. 1	CH2	Same as Table No. 1.	
UM 00521	Control pattern				
UM 00522	Positioning acceleration time				
UM 00523	Positioning deceleration time				
UM 00524-UM 00525	Positioning target speed				
UM 00526-UM 00527	Positioning movement amount				
UM 00528	Dwell time				
UM 00529	(Reserved for system)				
UM 0052A-UM 00533	The parameters (10 words) which are the same configuration as those for table no. 1 are allocated.	Table no. 2	CH2	Same as Table No. 1.	
UM 00534-UM 0053D		Table no. 3			
UM 0053E-UM 00547		Table no. 4			
UM 00548-UM 00551		Table no. 5			
UM 00552-UM 0055B		Table no. 6			
UM 0055C-UM 00565		Table no. 7			
UM 00566-UM 0056F		Table no. 8			
UM 00570-UM 00579		Table no. 9			
UM 0057A-UM 00583		Table no. 10			
UM 00584-UM 0058D		Table no. 11			
UM 0058E-UM 00597		Table no. 12			
UM 00598-UM 005A1		Table no. 13			
UM 005A2-UM 005AB		Table no. 14			
UM 005AC-UM 005B5		Table no. 15			
UM 005B6-UM 005BF		Table no. 16			
UM 005C0-UM 005C9		Table no. 17			
UM 005CA-UM 005D3		Table no. 18			
UM 005D4-UM 005DD		Table no. 19			
UM 005DE-UM 005E7		Table no. 20			
UM 005E8-UM 00619		(Reserved for system)			
UM 0061A	Control code	Table no. 1	CH3		
UM 0061B	Control pattern				
UM 0051C	Positioning acceleration time				

13.3 List of Unit Memories

Unit memory number (Hex.)	Content			Access unit	R	W
UM 0051D	Positioning deceleration time			1 W	A	A
UM 0051E-UM 0051F	Positioning target speed			2 W	A	A
UM 00520-UM 00521	Positioning movement amount			2 W	A	A
UM 00522	Dwell time			1 W	A	A
UM 00523	(Reserved for system)			-	-	-
UM 00624-UM 0062D	The parameters (10 words) which are the same configuration as those for table no. 1 are allocated.			Table no. 2		
UM 0062E-UM 00637				Table no. 3		
UM 00638-UM 00641				Table no. 4		
UM 00642-UM 0064B				Table no. 5		
UM 0064C-UM 00655				Table no. 6		
UM 00656-UM 0065F				Table no. 7		
UM 00660-UM 00669				Table no. 8		
UM 0066A-UM 00673				Table no. 9		
UM 00674-UM 0067D				Table no. 10		
UM 0067E-UM 00687				Table no. 11		
UM 00688-UM 00691				Table no. 12		
UM 00692-UM 0069B				Table no. 13		
UM 0069C-UM 006A5				Table no. 14		
UM 006A6-UM 006AF				Table no. 15		
UM 006B0-UM 006B9				Table no. 16		
UM 006BA-UM 006C3				Table no. 17		
UM 006C4-UM 006CD				Table no. 18		
UM 006CE-UM 006D7				Table no. 19		
UM 006D8-UM 006E1				Table no. 20		
UM 006E2-UM 00713				(Reserved for system)		
UM 00714-UM 00907	(Reserved for system)			-	-	-

Same as Table No. 1.

13.4 Unit Memory Detailed Information

13.4 Unit Memory Detailed Information

13.4.1 Alarm/Error/Warning

■ Error alarm setting

Unit memory No. (Hex)	Name	Setting range and description
UM 00062	Error alarm setting	Set whether or not to announce abnormality when a double word access error or warning occurs.

Setting value (UM 00062)

Bit no.	Settings	Default	Setting range and description	R	W
b0-b7	(Reserved for system)	—	—	—	—
b8	Double word access error annunciation	0: Announce	0: Announce 1: Not announced	A	A
b9	Warning annunciation	0: Announce	0: Announce 1: Not announced	A	A
b10-b15	(Reserved for system)	—	—	—	—

(Note 1) This is set in the "Multi I/O Unit Setting" screen of tool software FPWIN GR7 (Available since Ver.1.1), or using a user program.

■ Alarm / Error / Warning codes

Unit memory No. (Hex)	Name	Setting range and description	R	W
UM 00063	Double word access error occurrence address	Stores the address of a user program that an abnormal access was made when the double word access error has occurred.	A	—
UM 00064	Unit alarm code (H type only)	Stores the alarm code when the following alarm occurs. U20: Unit alarm	A	—
	Unit error code 1	Stores the error codes when the following errors occur. U1: Double word access error	A	—
UM 00065	Unit warning code	Stores the warning codes when the following warnings occur. U1: Interrupt setting error U2: Output setting error U3: Input voltage setting error U4: Pulse output setting error U5: PWM output setting error	A	—
UM 00066	Unit error code 2	Stores the error codes when the following errors occur. U26: System error U44: Positioning Error U45: Unit processing error	A	—

13.4.2 Input setting

■ Input setting

Unit memory No. (Hex)	Name	Default	Setting range and description	R	W
UM00100	Input voltage/ Input time constant setting (X0-X7)	H 2222	Set values indicating input voltage and input time constant.	A	A
UM00101	Input voltage/ Input time constant setting (X8-XF)	H 2222			

Allocation of unit memories

UM number	UM00101				UM00100			
Bit no.	b15-b12	b11-b8	b7-b4	b3-b0	b15-b12	b11-b8	b7-b4	b3-b0
I/O no. Input voltage	XF,XE,XD,XC		XB,XA,X9,X8		X7,X6, X5,X4		X3,X2, X1,X0	
I/O no. Input time constant	XF,XE	XD,XC	XB,XA	X9,X8	X7,X6	X5,X4	X3,X2	X1,X0
Setting value Initial value (Hex)	H2	H2	H 2	H 2	H 2	H 2	H 2	H 2

They are set by writing the following values which indicate the input voltage and input time constant for two inputs to the four bits of each unit memory. When allocating them using the tool software, it is not necessary to write them.

Setting value	Input voltage	Input time constant effective pulse width
H0	5V-24V mode	0
H 1		1 μ s
H2 (Default)		2 μ s
H 3		4 μ s
H 4		8 μ s
H 5		16 μ s
H 6		2 ms
H 7		4 ms
H8	12V-24V mode	0
H9		1 μ s
HA		2 μ s
HB		4 μ s
HC		8 μ s

13.4 Unit Memory Detailed Information

Setting value	Input voltage	Input time constant effective pulse width
HD		16 μ s
HE		2 ms
HF		4 ms

Precautions when making settings with programs

- Input voltage should be set in increments of four external input terminals (four groups).
- When the voltage settings of the higher two groups and lower two groups of input voltage are different, the 5V-24V mode takes priority.
- Input time constant should be set in increments of two external input terminals (eight groups).
- As the input voltage and input time constant are set for external input terminals, the settings are effective after the allocation of each function corresponding to inputs X0 to XF.

■ Input setting (Input time constant high resolution)

Unit memory No. (Hex)	Name	Default	Setting range and description	R	W
UM00070	Input time constant setting (X0-X7)	H FFFF	Set values indicating input time constant (high resolution).	A	A
UM00071	Input time constant setting (X8-XF)	H FFFF			

Allocation of unit memories

UM number	UM00071				UM00070			
	b15-b12	b11-b8	b7-b4	b3-b0	b15-b12	b11-b8	b7-b4	b3-b0
I/O no. Input time constant	XF,XE	XD,XC	XB,XA	X9,X8	X7,X6	X5,X4	X3,X2	X1,X0
Setting value Initial value (Hex)	H F	HF	HF	HF	HF	HF	HF	HF

The value (Hex) of input time constant (for two inputs) is written to the four bits of the unit memory. When allocating them using the tool software, it is not necessary to write them.

Setting value	Valid/Invalid	Input time constant effective pulse width
H0	Valid	0.5 μ s
H 1		1.5 μ s
H 2		32 μ s
H 3		64 μ s
H 4		96 μ s
H 5		128 μ s
H 6		256 μ s

Setting value	Valid/Invalid	Input time constant effective pulse width
H 7		8 ms
H8-HF	Invalid	-

Precautions when making settings with programs

- When the setting value is that in the range of H8 to HF, the setting is invalid.
- When the setting value is that in the range of H0 to H7, the input time constant setting is given priority over UM100-UM101.
- On the unit Ver.1.0x, the above input time constant values (the setting area of unit memories UM00070 and UM00071) cannot be set with the tool software (FPWIN GR7).

When the input time constants above are set in the tool software for the unit Ver.1.0x, they are set as 2 μ s. These values can be set by writing them into the unit memories using programs.

13.4.3 Output Setting

■ Output terminal polarity setting

Unit memory No. (Hex)	Name	Default	Setting range and description	R	W
UM00104	Output polarity setting	H FFFF	Set the value indicating output polarity. 4 points for 4 output terminals are allocated to 1 digit (4 bits).	A	A

Allocation of unit memories

UM number	UM00104			
Bit no.	b15-b12	b11-b8	b7-b4	b3-b0
Terminal number	B18-B15	B14-B11	A18-A15	A14-A11
I/O no.	YF-YC	YB-Y8	Y7-Y4	Y3-Y0
Setting value Initial value (Hex)	H F	H F	H F	H F

The values (Hex) of terminal number and I/O number (for four outputs) are written to the four bits of the unit memory. When allocating them using the tool software, it is not necessary to write them.

Setting value	Output logic / Output polarity
H0	Sink output / Negative logic (The low side turns on when the operation result is TRUE (1).)
H 1	Source output / Positive logic (The high side turns on when the operation result is TRUE (1).)
H 2	Push-pull output/negative logic (Low side ON/high side OFF when the operation result is TRUE (1))
H 3	Push-pull output/positive logic (High side ON/low side OFF when the operation result is TRUE (1))
H4 to HE	Disabled ^(Note 1)
HF (Default)	Not used ^(Note 2) Output OFF

13.4 Unit Memory Detailed Information

(Note 1) Do not use this setting.

(Note 2) The default value when the power is on has been set to ""Not used"".

Precautions when making settings with programs

- Output polarity should be set in increments of four external input terminals (four groups).
- Although it is possible to specify different polarities in the same unit, be very careful with the wirings.
- As the output polarities are set for the external output terminals (A11 to A18, B11 to B18), each function corresponding to the outputs X0 to XF is also effective for the allocated terminals.
- If different polarities are mixed in UM00104, a warning occurs to pay attention to the wiring. (The ERR. LED on this unit flashes.)

To disable warning announcement, set "Warning annunciation" to ""Not announce"" in the ""Multi I/O Unit Setting"" screen of tool software FPWIN GR7. (Available since Ver.1.1.) Or, set the bit 9 of UM00062 to 1.

Info.

- Set to agree the polarities of outputs to wirings. For details of the output specifications, refer to ""3.1.3 Output Specifications"".

■ Output contact terminal interrupt setting

Unit memory No. (Hex)	Name	Default	Setting range and description	R	W
UM00105	Output contact terminal interrupt setting	H FFFF	Set the I/O numbers allocated to terminal numbers.	A	A

Allocation of unit memories

UM number	UM00105			
Bit no.	b15-b12	b11-b8	b7-b4	b3-b0
Terminal number	B18-B15	B14-B11	A18-A15	A14-A11
I/O no.	YF-YC	YB-Y8	Y7-Y4	Y3-Y0
Setting value Initial value (Hex)	H F	H F	H F	H F

The values (Hex) of terminal number and I/O number (for four outputs) are written to the four bits of the unit memory.

Setting value	Output contact
H0	Y0-Y3
H 1	Y4-Y7
H 2	Y8-YB
H 3	YC-YF
H4 to HE	Disabled ^(Note 1)
HF (Default)	Basic arrangement ^(Note 2)

(Note 1) Do not use this setting.

(Note 2) The default value when the power is on has been set to ""Not used"".

13.4.4 Interrupt Setting Area

■ Interrupt setting

Unit memory No. (Hex)	Name	Default	Setting range and description	R	W
UM00108	Interrupt setting (INT0-INT3)	H FFFF	Specify conditions to occur the interrupts INT0 to INT7 when using the interrupt function.	A	A
UM00109	Interrupt setting (INT4-INT7)	H FFFF			

Allocation of unit memories

UM number	UM00109				UM00108			
Bit no.	b15-b12	b11-b8	b7-b4	b3-b0	b15-b12	b11-b8	b7-b4	b3-b0
INT number	INT7	INT6	INT5	INT4	INT3	INT2	INT1	INT0
Setting value Initial value (Hex)	H F	H F	H F	H F	H F	H F	H F	H F

They are set by writing the following values which indicate the condition for an interrupt to the four bits of each unit memory. When allocating them using the tool software, it is not necessary to write them.

Setting value	Interrupt Function	Connect to	Interrupt occurrence condition
H0	Used	Comparison Output Function ^(Note 1) (CMP0 to CMP7)	When the set value and comparison value match (=condition)
H 1			OFF→ON
H 2		Input terminal (X8 to XF)	ON > OFF ^(Note 2)
H 3			
H4 to H7	Disabled ^(Note 3)		
H8	Used	Comparison Output Function ^{(Note 5)(Note 6)} (CMP0 to CMP7)	Comparison OFF > ON/ON > OFF
H9			Comparison output OFF to ON
HA			Comparison output ON to OFF
HB			
HC to HE	Disabled ^(Note 3)		
HF (Default)	Not used ^(Note 4)		

(Note 1) INT0 to INT7 correspond to CMP0 to CMP7 respectively. When the relation between the comparison output set value and comparison value agrees with the condition set for the comparison counter allocation, the interrupt occurs.

13.4 Unit Memory Detailed Information

(Note 2) Always execute the interrupt clear instruction after setting, when selecting this setting.

(Note 3) Do not use this setting.

(Note 4) The default value when the power is on has been set to ""Not used"".

(Note 5) INT0 to INT7 correspond to CMP0 to CMP7 respectively. The interrupt occurs at the same timing as the comparison output function.

(Note 6) This condition cannot be set as an interrupt condition on the unit Ver.1.0x.

Note that the interrupt setting itself is set to "not used" if the above condition is set as the interrupt condition in FPWIN GR7 (Ver.2.12 or later).

i Info.

- Target channels of the match interrupt when using the comparison output function are specified in the area of the comparison output function. Refer to "[13.4.7 Comparison Output Setting Area](#)".
- The above INT numbers are different from interrupt program numbers INTPG.

13.4.5 Counter Mode Setting Area

■ Counter mode setting

Unit memory No. (Hex)	Name	Default	Setting range and description	R	W
UM0010C	Counter mode setting (CH0-CH1)	H 0F0F	Specify a counter mode. Each channel is allocated 8 bits (input mode in 4 bits, function in 4 bits).	A	A
UM 0010D	Counter mode setting (CH2-CH3)	H 0F0F			

Allocation of unit memories

UM number	UM0010D				UM0010C			
	b15-b12	b11-b8	b7-b4	b3-b0	b15-b12	b11-b8	b7-b4	b3-b0
Setting channel	CH3		CH2		CH1		CH0	
Setting item	Input mode	Functions	Input mode	Functions	Input mode	Functions	Input mode	Functions
Setting value Initial value (Hex)	H0	H F	H0	H F	H0	H F	H0	H F

The values (Hex) of setting channel and setting item are written to the four bits of the unit memory. When allocating them using the tool software, it is not necessary to write them.

Setting value (Input mode)

Setting value	Functions	Multiplication function
H0 (Default)	Direction distinction ^(Note 1)	None
H 1	Individual input	
H 2	Phase input	1 multiple
H 3		2 multiple
H 4		4 multiple
H5 to HF	Not used	

(Note 1) It shows the default value on the unit side.

Setting value (Function)

Setting value	Count mode	Elapsed value hold mode
H0	Ring	Not used
H 1	Linear	
H 2	Ring	Used ^(Note 3)
H 3	Linear	
H4 to HE	Disabled ^(Note 1)	Disabled
HF (Default)	Not used ^(Note 2)	

(Note 1) Do not use this setting.

(Note 2) It shows the default value on the unit side.

(Note 3) The counters CH2/CH3 cannot be used in the elapsed value hold mode.

13.4.6 Counter Monitor Setting Area

Unit memory No. (Hex)	Name	Default	Setting range and description	R	W
UM 00110 UM 00111	Counter elapsed value (CH0)	K 0	Stores counter elapsed values. They can also be written using user programs. Setting range: -2,147,483,648 to +2,147,483,647 Signed 32-bit integer	A	A
UM 00112 UM 00113	Counter elapsed value (CH1)				
UM 00114 UM 00115	Counter elapsed value (CH2)				
UM 00116 UM 00117	Counter elapsed value (CH3)				
UM 00114 UM 00115	Counter elapsed value Hold value (CH0)	K 0	Stores the elapsed values at the time of the input of trigger signals when using the counter elapsed value hold function. They can also be written using user programs. Setting range: -2,147,483,648 to +2,147,483,647	A	A
UM 00116 UM 00117	Counter elapsed value				

13.4 Unit Memory Detailed Information

Unit memory No. (Hex)	Name	Default	Setting range and description	R	W
	Hold value (CH1)		Signed 32-bit integer		
UM 00118 UM 00119	Counter preset value (CH0)	K 0	Input the preset value when the counter is reset. Setting range: -2,147,483,648 to +2,147,483,647 Signed 32-bit integer	A	A
UM 0011A UM 0011B	Counter preset value (CH1)				
UM 0011C UM 0011D	Counter preset value (CH2)				
UM 0011E UM 0011F	Counter preset value (CH3)				
UM 00120 UM 00121	Counter lower limit value (CH0)	K -2147483648	Set the counter lower limit value. Setting range: -2,147,483,648 to +2,147,483,647 Signed 32-bit integer	A	A
UM 00122 UM 00123	Counter lower limit value (CH1)				
UM 00124 UM 00125	Counter lower limit value (CH2)				
UM 00126 UM 00127	Counter lower limit value (CH3)				
UM 00128 UM 00129	Counter upper limit value (CH0)	K 2147483647	Set the counter upper limit value. Setting range: -2,147,483,648 to +2,147,483,647 Signed 32-bit integer	A	A
UM 0012A UM 0012B	Counter upper limit value (CH1)				
UM 0012C UM 0012D	Counter upper limit value (CH2)				
UM 0012E UM 0012F	Counter upper limit value (CH3)				
UM 00130 UM 00131	Counter input Frequency measurement value (CH0)	H0	Stores the measurement values of frequencies of counter input. Range: 0 to 500,000 Unsigned 32-bit integer Unit: Hz	A	—
UM 00132 UM 00133	Counter input Frequency measurement value (CH1)				
UM 00134 UM 00135	Counter input Frequency measurement value (CH2)				
UM 00136 UM 00137	Counter input Frequency measurement value (CH3)				

(Note 1) UM00114 and UM00115 can be used for either counter elapsed values (CH2) or counter hold values (CH0). UM00116 and UM00117 can be used for either counter elapsed values (CH3) or counter hold values (CH1).

13.4.7 Comparison Output Setting Area

Unit memory No. (Hex)	Name	Default	Setting range and description	R	W
UM 00140	Comparison counter allocation (CMP0-CMP3)	HFFFF	Specify conditions to turn on the comparison outputs CMP0 to CMP7 when using the comparison function. 1 digit and 4 bits are allocated to 1 comparison contact.	A	A
UM 00141	Comparison counter allocation (CMP4-CMP7)	HFFFF			
UM 00142	Comparison output enable setting (CMP0-CMP3)	HFFFF	Specify whether or not to enable the comparison outputs CMP0 to CMP7 when using the comparison function. 1 digit and 4 bits are allocated to 1 comparison contact.	A	A
UM 00143	Comparison output enable setting (CMP4-CMP7)	HFFFF			
UM 00144 UM 00145	Comparison value (CMP0)	K 0	Set when using the comparison function. They can also be written using user programs. Setting range: -2,147,483,648 to +2,147,483,647 Signed 32-bit integer The setting range of the channel for which the positioning function is set is different. For interpolation axis control: -1,073,741,824 to +1,073,741,823 For interpolation axis control: -8,388,608 to +8,388,607	A	A
UM 00146 UM 00147	Comparison value (CMP1)				
UM 00148 UM 00149	Comparison value (CMP2)				
UM 0014A UM 0014B	Comparison value (CMP3)				
UM 0014C UM 0014D	Comparison value (CMP4)				
UM 0014E UM 0014F	Comparison value (CMP5)				
UM 00150 UM 00151	Comparison value (CMP6)				
UM 00152 UM 00153	Comparison value (CMP7)				

Allocation of unit memories (UM00141/UM00140) : Comparison counter allocation

UM number	UM00141				UM00140			
	b15-b12	b11-b8	b7-b4	b3-b0	b15-b12	b11-b8	b7-b4	b3-b0
CMP number	CMP7	CMP6	CMP5	CMP4	CMP3	CMP2	CMP1	CMP0
Setting value Initial value (Hex)	H F	H F	H F	H F	H F	H F	H F	H F

13.4 Unit Memory Detailed Information

Set by writing the values below to the 4 bits allocated to each comparison output number. When allocating them using the tool software, it is not necessary to write them.

Setting value (UM00141/UM00140)

Setting value	Functions		
	Comparison output setting	Counter channel to be compared	
H0	ON when elapsed value is smaller than setting value	HSC-CH0	External input counter
H 1		HSC-CH1	
H 2		HSC-CH2	
H 3		HSC-CH3	
H 4	ON when elapsed value is larger than or equal to setting value	HSC-CH0	External input counter
H 5		HSC-CH1	
H 6		HSC-CH2	
H 7		HSC-CH3	
H8	ON when elapsed value is smaller than setting value	PLSC-CH0	Pulse output/PWM output counter
H9		PLSC -CH1	
HA		PLSC -CH2	
HB		PLSC -CH3	
HC	ON when elapsed value is larger than or equal to setting value	PLSC-CH0	Pulse output/PWM output counter
HD		PLSC -CH1	
HE		PLSC -CH2	
HF (Default)		PLSC -CH3	

Allocation of unit memories (UM00143/UM00142) : Comparison output enable setting

UM number	UM00143				UM00142			
Bit no.	b15-b12	b11-b8	b7-b4	b3-b0	b15-b12	b11-b8	b7-b4	b3-b0
CMP number	CMP7	CMP6	CMP5	CMP4	CMP3	CMP2	CMP1	CMP0
Setting value Initial value (Hex)	H F	H F	H F	H F	H F	H F	H F	H F

Settings to enable/disable the comparison output and the output destination are set by writing the values on the next page to the 4 bits allocated to each comparison output number. When allocating them using the tool software, it is not necessary to write them.

Setting value	Functions	
	Comparison output setting	Output destination
H0	Enabled	External terminal/Internal I/O ^(Note 1)
H 1		Internal I/O only ^{(Note 2)(Note 3)}
H2 to HE	Disabled	Disabled

13.4 Unit Memory Detailed Information

Setting value	Functions	
	Comparison output setting	Output destination
HF (Default)	Disabled	Disabled

(Note 1) If it conflicts with the deviation counter clear when setting the positioning function for the positioning unit (H type), the external terminal cannot be selected as the output destination.

(Note 2) For the unit Ver.1.0x, ""Internal I/O only"" cannot be selected as the output destination. When ""Internal I/O only"" is selected in the tool software, the comparison output function is set not to be used.

(Note 3) When ""Internal I/O only"" is set as the output destination, the terminal is the general-purpose I/O.

13.4.8 Pulse Output / PWM Output Setting Area

Unit memory No. (Hex)	Name	Default	Setting range and description	R	W
UM 0015C	Pulse/PWM Function Settings (PLS0-PLS3/PWM0-PWM3)	H FFFF	Specify the data update timing and output mode of pulse output or PWM output when using the pulse output function or PWM output function. 1 digit and 4 bits are allocated to 1 output channel.	A	A
UM 0015D	Pulse/PWM pulse counter function setting (PLS0-PLS3/PWM0-PWM3)	H FFFF	Set to use the pulse output counter. 1 digit and 4 bits are allocated to 1 output channel.	A	A

Allocation of unit memories: Pulse/PWM function setting

UM number	UM0015D				UM0015C			
	b15-b12	b11-b8	b7-b4	b3-b0	b15-b12	b11-b8	b7-b4	b3-b0
Setting channel	PLS3	PLS2	PLS1	PLS0	PLS3	PLS2	PLS1	PLS0
	PWM3	PWM2	PWM1	PWM0	PWM3	PWM2	PWM1	PWM0
Setting value Initial value (Hex)	H F	H F	H F	H F	H F	H F	H F	H F

Set this by writing the following value to the 4 bits allocated to each channel. When allocating them using the tool software, it is not necessary to write them.

Setting value (UM0015C)

Setting value	Functions		
	Function s	Data update timing	Output mode
H0	PWM	When PWMx start signal rises	-
H1		When PWMx start signal rises or comparison output is executed	

13.4 Unit Memory Detailed Information

Setting value	Functions		
	Function s	Data update timing	Output mode
H 2		When PWMx start signal rises or data is updated	
H 3	PLS	When PLSx start signal rises	Direction distinction
H 4			Individual
H 5		When PLSx start signal rises or comparison output is executed	Direction distinction
H 6			Individual
H 7		When PLSx start signal rises or data is updated	Direction distinction
H 8			Individual
H 9		When PLSx start signal rises	Individual phase
HA			Comparison match stop
HB		When PLSx start signal rises or comparison output is executed	Individual phase
HC			Comparison match stop
HD		When PLSx start signal rises or data is updated	Individual phase
HE			Comparison match stop
HF (Default)		Not used	

Setting value (UM0015D)

Setting value	Functions
	Usage of pulse output counter
H0	Used
H1 to HE	Not used
HF (Default)	Not used

13.4.9 Pulse Output/PWM Output Monitor Setting Area

■ Status Flag

Unit memory No. (Hex)	Name	Default	Setting range and description	R	W
UM 0015E	Pulse/PWM status flag (PLS0-PLS1/ PWM0-PWM1)	H 1414	The setting status can be monitored when using the pulse output function or PWM output function. 1 byte (8 bits) are allocated to every 1 point on the Pulse output/PWM output counter.	A	—
UM 0015F	Pulse/PWM status flag (PLS2-PLS3/ PWM2-PWM3)	H 1414			

Allocation of unit memories: Pulse/PWM status flag

UM number	UM0015F				UM0015E			
Bit no.	b15-b8		b7-b0		b15-b8		b7-b0	
Setting channel	PLS3		PLS2		PLS1		PLS0	
	PWM3		PWM2		PWM1		PWM0	
Monitor value Initial value (Hex)	H1	H4	H1	H4	H1	H4	H1	H4

Monitor values (UM0015F / UM0015E)

Bit no.		Settings	Value	
		Functions	1	0
b8	b0	Pulse output start logic ^(Note 1)	ON start	OFF start
b9	b1	Duty error	100.1% or more	0.0% to 100.0%
b10	b2	Duty 0% setting flag	0	Other than 0
b11	b3	Frequency setting error flag During pulse output	500001 Hz or more	Less than 100001 Hz
		Frequency setting error flag During PWM output	100001 Hz or more	Less than 100001 Hz
b12	b4	Frequency 0Hz setting flag	0 Hz	Other than 0 Hz
b13	b5	Flag when setting PWM output	Setting	Unset
b14	b6	Flag when setting pulse output	Setting	Unset
b15	b7	Busy flag	During output	Output Off

(Note 1) Since Multi I/O Unit Ver.1.1, it is possible to select "ON start" or "OFF start" for starting the pulse output with the pulse output function. In the Ver.1.0x unit, only "OFF start" is available. (Cannot change)

■ Monitor Area

Unit memory No. (Hex)	Name	Default	Setting range and description	R	W
UM 00160 UM 00161	PLS/PWM output frequency (CH0)	H0	Stores the frequencies of pulse output or PWM output. They can also be written using user programs. (During Pulse output) Range: 0 to 500,000 Unsigned 32-bit integer (During PWM output) Range: 0 to 100,000 Unsigned 32-bit integer	A	A
UM 00162 UM 00163	PLS/PWM output frequency (CH1)				
UM 00164 UM 00165	PLS/PWM output frequency (CH2)				
UM 00166 UM 00167	PLS/PWM output frequency (CH3)				
UM 00168 UM 00169	PWM output duty (CH0)	H0	Stores the duty ratios of PWM output. They can also be written using user programs. Range: 0 to 1,000 (0.0% to 100.0%)	A	A

13.4 Unit Memory Detailed Information

Unit memory No. (Hex)	Name	Default	Setting range and description	R	W
UM 0016A UM 0016B	PWM output duty (CH1)		Unsigned 32-bit integer		
UM 0016C UM 0016D	PWM output duty (CH2)				
UM 0016E UM 0016F	PWM output duty (CH3)				
UM 00170 UM 00171	PLS/PWM output counter elapsed value (CH0)	K 0	Stores the counter elapsed values when using the pulse output/PWM output function. They can also be written using user programs. Setting range: -2,147,483,648 to +2,147,483,647 Signed 32-bit integer (Note 1)	A	A
UM 00172 UM 00173	PLS/PWM output counter elapsed value (CH1)				
UM 00174 UM 00175	PLS/PWM output counter elapsed value (CH2)				
UM 00176 UM 00177	PLS/PWM output counter elapsed value (CH3)				
UM 00178 UM 00179	PLS/PWM output counter lower limit value (CH0)	K -2147483648	Set the lower limit value of the counter for pulse output/PWM output. Setting range: -2,147,483,648 to +2,147,483,647 Signed 32-bit integer (Note 2)	A	A
UM 0017A UM 0017B	PLS/PWM output counter lower limit value (CH1)				
UM 0017C UM 0017D	PLS/PWM output counter lower limit value (CH2)				
UM 0017E UM 0017F	PLS/PWM output counter lower limit value (CH3)				
UM 00180 UM 00181	PLS/PWM output (CH0)	K 2147483647	Set the upper limit value of the counter for pulse output/PWM output. Setting range: -2,147,483,648 to +2,147,483,647 Signed 32-bit integer (Note 2)	A	A
UM 00182 UM 00183	PLS/PWM output counter upper limit value (CH1)				
UM 00184 UM 00185	PLS/PWM output counter upper limit value (CH2)				
UM 00186 UM 00187	PLS/PWM output counter upper limit value (CH3)				

(Note 1) The "PLS/PWM counter elapsed value" of a channel for which the positioning function is selected cannot be rewritten.

(Note 2) The "PLS/PWM counter lower limit value" and "PLS/PWM counter upper limit value" of a channel for which the positioning function is selected cannot be rewritten. Even if they are set, the settings are invalid.

13.5 Unit Memory Detailed Information (H type)

13.5.1 Common Area

A: Available, -: Not available

Unit memory No. (Hex)	Name	Default	Content	R	W																		
UM 00200	Axis setting	H0	Stores used channels (axes) and usage methods. Monitor using binary display.	A	A																		
			<table border="1"> <thead> <tr> <th>bit no.</th> <th>Settings</th> </tr> </thead> <tbody> <tr> <td>0</td> <td>Not use CH0 (0) / Use (1)</td> </tr> <tr> <td>1</td> <td>Not use CH1 (0) / Use (1)</td> </tr> <tr> <td>2</td> <td>Not use CH2 (0) / Use (1)</td> </tr> <tr> <td>3</td> <td>Not use CH3 (0) / Use (1)</td> </tr> <tr> <td>7-4</td> <td>Disable the setting</td> </tr> <tr> <td>8</td> <td>Use CH0/CH1 as interpolation axis Not use (0)/Use (1)</td> </tr> <tr> <td>9</td> <td>Use CH2/CH3 as interpolation axis Not use (0)/Use (1)</td> </tr> <tr> <td>15-10</td> <td>Disable the setting</td> </tr> </tbody> </table>			bit no.	Settings	0	Not use CH0 (0) / Use (1)	1	Not use CH1 (0) / Use (1)	2	Not use CH2 (0) / Use (1)	3	Not use CH3 (0) / Use (1)	7-4	Disable the setting	8	Use CH0/CH1 as interpolation axis Not use (0)/Use (1)	9	Use CH2/CH3 as interpolation axis Not use (0)/Use (1)	15-10	Disable the setting
			bit no.			Settings																	
			0			Not use CH0 (0) / Use (1)																	
			1			Not use CH1 (0) / Use (1)																	
			2			Not use CH2 (0) / Use (1)																	
			3			Not use CH3 (0) / Use (1)																	
			7-4			Disable the setting																	
8	Use CH0/CH1 as interpolation axis Not use (0)/Use (1)																						
9	Use CH2/CH3 as interpolation axis Not use (0)/Use (1)																						
15-10	Disable the setting																						
UM 00201	Positioning repeat count (CH0)	H0	Stores the repeat count in decimal when using the repeat control in the position control.	A	A																		
UM 00202	Positioning repeat count (CH1)	H0	<table border="1"> <thead> <tr> <th>Setting value</th> <th>Operation</th> </tr> </thead> <tbody> <tr> <td>0 or 1</td> <td>Not repeat an operation.</td> </tr> <tr> <td>2 to 254</td> <td>Repeat an operation for a specified number of times.</td> </tr> <tr> <td>255 or more</td> <td>Repeat an operation infinitely.</td> </tr> </tbody> </table>	Setting value	Operation	0 or 1	Not repeat an operation.	2 to 254	Repeat an operation for a specified number of times.	255 or more	Repeat an operation infinitely.	A	A										
Setting value	Operation																						
0 or 1	Not repeat an operation.																						
2 to 254	Repeat an operation for a specified number of times.																						
255 or more	Repeat an operation infinitely.																						
UM 00203	Positioning repeat count (CH2)	H0	0 or 1	A	A																		
UM 00204	Positioning repeat count (CH3)	H0	2 to 254	A	A																		
			255 or more																				
UM 00204 -UM 00206	Reserved for system	—	—	—	—																		
UM 00207	Error code	H0	Stores a generated positioning error code in Hex format (hexadecimal) when using the pulse output function (table setting mode). * The higher 8 bits indicate the channel number and the lower 8 bits indicate the error code.	A	A																		
UM 00208	Reserved for system	—	—	—	—																		
UM 00209	Starting table number (CH0)	H0	Specify the table number to be started when a positioning start signal is input. Setting value: 1 to 20 When setting 0, the table number is 1.	A	A																		
UM 0020A	Starting table number (CH1)	H0		A	A																		
UM 0020B	Starting table number (CH2)	H0		A	A																		

13.5 Unit Memory Detailed Information (H type)

Unit memory No. (Hex)	Name	Default	Content	R	W
UM 0020C	Starting table number (CH3)	H0		A	A
UM 0020D -UM 0020F	Reserved for system	—	—	—	—
UM 00210	Simultaneous starting table number (CH0)	H0	Specify the table number to be started when a positioning simultaneous start signal is input. Setting value: 0 Specified channels do not start simultaneously. Setting value: 1 to 20 Specified channels start with the set table number.	A	A
UM 00211	Simultaneous starting table number (CH1)	H0		A	A
UM 00212	Simultaneous starting table number (CH2)	H0		A	A
UM 00213	Simultaneous starting table number (CH3)	H0		A	A
UM 00214 -UM 002D	Reserved for system	—	—	—	—

13.5.2 Axis Information Area

A: Available, -: Not available

Unit memory No. (Hex)	Name	Default	Content	R	W
UM 0021E	Active or execution done table (CH0)	H0	Stores the monitor values of the positioning table numbers during the execution or on the completion of each channel.	A	—
UM 0021F	Repeat count current value (CH0)	H0	Stores the repeat count during the operation of each channel. The execution start time is counted as "1". When the repeat count exceeds the upper limit, it returns to "0". When the repeat operation is not enabled, "0" is stored at the positioning control start time. Stored value: 0 to 65535	A	—
UM 00220 -UM 00221	Elapsed value (Current value coordinate) (CH0)	K0	Stores the elapsed values (current value coordinate) of each channel. Range: -1,073,741,824 to +1,073,741,823 For the interpolation control, the setting range is as follows. -8388608 to +8388607	A	A
UM 00222 -UM 00227	Reserved for system	—	—	—	—
UM 00228	Active or execution done table (CH1)	H0	Same as CH0.	A	—
UM 00229	Repeat count current value (CH1)	H0	Same as CH0.	A	—

13.5 Unit Memory Detailed Information (H type)

Unit memory No. (Hex)	Name	Default	Content	R	W
UM 0022A -UM 0022B	Elapsed value (Current value coordinate) (CH1)	K0	Same as CH0.	A	A
UM 0022C -UM 00231	Reserved for system	—	—	—	—
UM 00232	Active or execution done table (CH2)	H0	Same as CH0.	A	—
UM 00233	Repeat count current value (CH2)	H0	Same as CH0.	A	—
UM 00234 -UM 00235	Elapsed value (Current value coordinate) (CH2)	K0	Same as CH0.	A	A
UM 00236 -UM 0023B	Reserved for system	—	—	—	—
UM 0023C	Active or execution done table (CH3)	H0	Same as CH0.	A	—
UM 0023D	Repeat count current value (CH3)	H0	Same as CH0.	A	—
UM 0023E -UM 0023F	Elapsed value (Current value coordinate) (CH3)	K0	Same as CH0.	A	A
UM 00240 -UM 00245	Reserved for system	—	—	—	—

13.5.3 Axis Setting Area

A: Available, -: Not available

Unit memory No. (Hex)	Name	Default	Content	R	W									
UM 00264	Pulse output control code	H0	<p>Stores the settings of pulse output, home position, near home position, and limit signal of each channel. Monitor in binary format.</p> <table border="1"> <thead> <tr> <th>bit no.</th> <th>Item</th> <th>Settings</th> </tr> </thead> <tbody> <tr> <td>0</td> <td>Output method</td> <td>0: Pulse/Sign 1: CW/CCW</td> </tr> <tr> <td>1</td> <td>Rotation direction</td> <td>0: Elapsed value + Direction is CW. (Forward OFF/Reverse ON) 1: Elapsed value + Direction is CCW. (Forward ON/Reverse OFF)</td> </tr> </tbody> </table>	bit no.	Item	Settings	0	Output method	0: Pulse/Sign 1: CW/CCW	1	Rotation direction	0: Elapsed value + Direction is CW. (Forward OFF/Reverse ON) 1: Elapsed value + Direction is CCW. (Forward ON/Reverse OFF)	A	A
bit no.	Item	Settings												
0	Output method	0: Pulse/Sign 1: CW/CCW												
1	Rotation direction	0: Elapsed value + Direction is CW. (Forward OFF/Reverse ON) 1: Elapsed value + Direction is CCW. (Forward ON/Reverse OFF)												

13.5 Unit Memory Detailed Information (H type)

Unit memory No. (Hex)	Name	Default	Content			R	W
			bit no.	Item	Settings		
			2	Home position logic	0: Normal Open (A contact) 1: Normal Close (B contact)		
			3	Near home input logic			
			4	Limit (+) logic			
			5	Limit (-) logic			
			6-15	Disable the setting			
UM 00265 -UM 00266	Startup Speed	U100	Stores the settings of the startup speed for each operation of each channel in decimal. Setting range: 1 to 100,000			A	A
UM 00267	Home return method	HFF	Stores the settings of home return patterns of each channel. H0: DOG method 1 H1: DOG method 2 H2: DOG method 3 H3: Setting error H4: Setting error H5: Home position method (Z phase method) H6: Data set method HFF: Not use			A	A
UM 00268	Home return direction	H0	Stores the settings of home return operation direction in decimal. 0: Elapsed value decreasing direction (Limit - direction) 1: Elapsed value increasing direction (Limit + direction)			A	A
UM 00269	Home return acceleration time	U100	Stores the settings of the acceleration time for the home return of each channel in decimal. It indicates the time from the startup speed to the home return target speed. Setting range: 1 to 10,000 (ms)			A	A
UM 0026A	Home return deceleration time	U100	Stores the settings of the deceleration time for the home return of each channel in decimal. It indicates the time from the home return target speed to the startup speed. Setting range: 1 to 10,000 (ms)			A	A
UM 0026B -UM 0026C	Home return target speed	U1000	Stores the settings of the target speed for the home return of each channel in decimal. Setting range: 1 to 100,000			A	A
UM 0026D -UM 0026E	Home return creep speed	U100	Stores the settings of the creep speed for the home return of each channel in decimal. Setting range: 1 to 100,000			A	A
UM 0026F	Deviation counter clear time	U1	Stores the settings of the deviation counter clear signal ON time after the completion of home return of each channel in decimal.			A	A

13.5 Unit Memory Detailed Information (H type)

Unit memory No. (Hex)	Name	Default	Content	R	W
			ON time setting range: 1 to 100 (ms) In the case of 0, no deviation counter clear signal is output. In the case of 100 or more, the ON time is set to 100 ms.		
UM 00270 -UM 00271	Coordinate origin	K0	Stores the elapsed values (current value) after the home return. Range: -1,073,741,824 to +1,073,741,823 For the interpolation control, the setting range is as follows. -8388608 to +8388607	A	A
UM 00272	JOG acceleration time	H0	Stores the settings of the acceleration time for the JOG operation of each channel in decimal. It indicates the acceleration time from 0 Hz to 100 kHz. Setting range: 0 to 10,000 (ms)	A	A
UM 00273	JOG deceleration time	H0	Stores the settings of the deceleration time for the JOG operation of each channel in decimal. It indicates the deceleration time from 100 kHz to 0 Hz. Setting range: 0 to 10,000 (ms)	A	A
UM 00274 -UM 00275	JOG operation target speed	U1000	Stores the settings of the target speed for the JOG operation of each channel in decimal. Setting range: 1 to 100,000	A	A
UM 00276 -UM 00277	J point change target speed	U1000	Stores the settings of the target speed for changing the J-point control speed for each channel in decimal. Setting range: 1 to 100,000	A	A
UM 00278	Emergency stop deceleration time	U100	Stores the settings of the deceleration time for the emergency stop operation of each channel in decimal. It indicates the deceleration time from 100 kHz to 0 Hz. Setting range: 0 to 10,000 (ms)	A	A
UM 00279	Limit stop deceleration time	U100	Stores the settings of the deceleration time for the limit stop operation of each channel in decimal. It indicates the deceleration time from 100 kHz to 0 Hz. Setting range: 0 to 10,000 (ms)	A	A
UM 0027A -UM 00281	Reserved for system	—	—	—	—

(Note 1) The unit memory numbers in the table above are for CH0. For the numbers for CH1 to CH3, refer to "[Correspondence table of unit memory numbers](#)".

(Note 2) The emergency stop deceleration time and limit stop deceleration time indicates the deceleration time in the section from 100 kHz to 0 Hz. When the speed during the operation is less than 100 kHz, the actual acceleration/deceleration time is shorter than the set time.

■ Correspondence table of unit memory numbers

Name	Unit memory number (Hex.)			
	CH0	CH1	CH2	CH3
Pulse output control code	UM00264	UM00282	UM002A0	UM002BE

13.5 Unit Memory Detailed Information (H type)

Name	Unit memory number (Hex.)			
	CH0	CH1	CH2	CH3
Startup Speed	UM00265 -UM00266	UM00283 -UM00284	UM002A1 -UM002A2	UM002BF -UM002C0
Home return method	UM00267	UM00285	UM002A3	UM002C1
Home return direction	UM00268	UM00286	UM002A4	UM002C2
Home return acceleration time	UM00269	UM00287	UM002A5	UM002C3
Home return deceleration time	UM0026A	UM00288	UM002A6	UM002C4
Home return target speed	UM0026B -UM0026C	UM00289 -UM0028A	UM002A7 -UM002A8	UM002C5 -UM002C6
Home return creep speed	UM0026D -UM0026E	UM0028B -UM0028C	UM002A9 -UM002AA	UM002C7 -UM002C8
Deviation counter clear time	UM0026F	UM0028D	UM002AB	UM002C9
Coordinate origin	UM00270 -UM00271	UM0028E -UM0028F	UM002AC -UM002AD	UM002CA -UM002CB
JOG acceleration time	UM00272	UM00290	UM002AE	UM002CC
JOG deceleration time	UM00273	UM00291	UM002AF	UM002CD
JOG operation target speed	UM00274 -UM00275	UM00292 -UM00293	UM002B0 -UM002B1	UM002CE -UM002CF
J point change target speed	UM00276 -UM00277	UM00294 -UM00295	UM002B2 -UM002B3	UM002D0 -UM002D1
Emergency stop deceleration time	UM00278	UM00296	UM002B4	UM002D2
Limit stop deceleration time	UM00279	UM00297	UM002B5	UM002D3
Reserved for system	UM0027A -UM00281	UM00298 -UM0029F	UM002B6 -UM002BD	UM002D4 -UM002DB

13.5.4 Positioning Table Area

A: Available, -: Not available

Unit memory No. (Hex)	Name	Default	Content	R	W									
UM 0032C	Control code	H0	Stores the settings of the position specification method for the positioning operation.	A	A									
			<table border="1"> <thead> <tr> <th>bit no.</th> <th>Item</th> <th>Settings</th> </tr> </thead> <tbody> <tr> <td>0</td> <td>Control method</td> <td>0: Increment mode 1: Absolute mode</td> </tr> <tr> <td>1-15</td> <td>Disable the setting</td> <td></td> </tr> </tbody> </table>			bit no.	Item	Settings	0	Control method	0: Increment mode 1: Absolute mode	1-15	Disable the setting	
			bit no.			Item	Settings							
0	Control method	0: Increment mode 1: Absolute mode												
1-15	Disable the setting													
UM0032D	Control pattern	H0	Stores the settings of single axis and interpolation operation pattern of positioning operation. In the interpolation	A	A									

13.5 Unit Memory Detailed Information (H type)

Unit memory No. (Hex)	Name	Default	Content	R	W
			<p>operation, the setting for the axis with the smallest number in an axis group is effective.</p> <p>Channel specification H00: Linear interpolation (Composite speed) H01: Linear interpolation (Long axis speed)</p> <p>Control pattern H00: E-point control (End point control) H01: P-point control (Pass point control) H02: C-point control (Continuance point control) H03: J-point control (Speed point control)</p>		
UM0032E	Positioning acceleration time	U100	<p>Stores the settings of the acceleration time for the positioning operation. It indicates the acceleration time from the startup speed to the target speed. However, in the case of J-point table, it indicates the acceleration time from 0 Hz to 100 kHz.</p> <p>Setting range: 1 to 10,000 ms</p>	A	A
UM0032F	Positioning deceleration time	U100	<p>Stores the settings of the deceleration time for the positioning operation. It indicates the deceleration time from the target speed to the startup speed. However, in the case of J-point table, it indicates the deceleration time from 100 kHz to 0 Hz.</p> <p>Setting range: 1 to 10,000 ms</p>	A	A
UM00330 -UM00331	Positioning target speed	U1000	<p>Stores the settings of the target speed for the positioning operation. In the interpolation operation, the setting for the axis with the smallest number in an axis group is effective.</p> <p>Setting range: 1 to 100,000</p>	A	A
UM00332 -UM00333	Positioning movement amount	K0	<p>Stores the settings of the movement amount for the positioning operation.</p> <p>Setting range: -1,073,741,824 to +1,073,741,823</p> <p>For the interpolation control, the setting range is as follows. -8388608 to +8388607</p>	A	A
UM00334	Dwell time	H0	<p>Stores the settings of dwell time.</p> <p>Setting range: 0 to 32,767 ms</p>	A	A
UM00335	Reserved for system	—	—	—	—

(Note 1) The unit memory numbers in the table above are for CH0. For the numbers for CH1 to CH3, refer to ""Correspondence table of unit memory numbers"" given below.

■ Correspondence table of unit memory numbers

Table No.	Name	Unit memory number (Hex.)			
		CH0	CH1	CH2	CH3
1	Control code	UM0032C	UM00426	UM00520	UM0061A
	Control pattern	UM0032D	UM00427	UM00521	UM0061B
	Positioning acceleration time	UM0032E	UM00428	UM00522	UM0061C
	Positioning deceleration time	UM0032F	UM00429	UM00523	UM0061D

13.5 Unit Memory Detailed Information (H type)

Table No.	Name	Unit memory number (Hex.)			
		CH0	CH1	CH2	CH3
	Positioning target speed	UM00330 -UM00331	UM0042A -UM0042B	UM00524 -UM00525	UM0061E -UM0061F
	Positioning movement amount	UM00332 -UM00333	UM0042C -UM0042D	UM00526 -UM00527	UM00620 -UM00621
	Dwell time	UM00334	UM0042E	UM00528	UM00622
	Reserved for system	UM00335	UM0042F	UM00529	UM00623
2	Control code	UM00336	UM00430	UM0052A	UM00624
	Control pattern	UM00337	UM00431	UM0052B	UM00625
	Positioning acceleration time	UM00338	UM00432	UM0052C	UM00626
	Positioning deceleration time	UM00339	UM00433	UM0052D	UM00627
	Positioning target speed	UM0033A -UM0033B	UM00434 -UM00435	UM0052E -UM0052F	UM00628 -UM00629
	Positioning movement amount	UM0033C -UM0033D	UM00436 -UM00437	UM00530 -UM00531	UM0062A -UM0062B
	Dwell time	UM0033E	UM00438	UM00532	UM0062C
	Reserved for system	UM0033F	UM00439	UM00533	UM0062D
3	Control code	UM00340	UM0043A	UM00534	UM0062E
	Control pattern	UM00341	UM0043B	UM00535	UM0062F
	Positioning acceleration time	UM00342	UM0043C	UM00536	UM00630
	Positioning deceleration time	UM00343	UM0043D	UM00537	UM00631
	Positioning target speed	UM00344 -UM00345	UM0043E -UM0043F	UM00538 -UM00539	UM00632 -UM00633
	Positioning movement amount	UM00346 -UM00347	UM00440 -UM00441	UM0053A -UM0053B	UM00634 -UM00635
	Dwell time	UM00348	UM00442	UM0053C	UM00636
	Reserved for system	UM00349	UM00443	UM0053D	UM00637
4	Control code	UM0034A	UM00444	UM0053E	UM00638
	Control pattern	UM0034B	UM00445	UM0053F	UM00639
	Positioning acceleration time	UM0034C	UM00446	UM00540	UM0063A
	Positioning deceleration time	UM0034D	UM00447	UM00541	UM0063B
	Positioning target speed	UM0034E -UM0034F	UM00448 -UM00449	UM00542 -UM00543	UM0063C -UM0063D
	Positioning movement amount	UM00350 -UM00351	UM0044A -UM0044B	UM00544 -UM00545	UM0063E -UM0063F
	Dwell time	UM00352	UM0044C	UM00546	UM00640

13.5 Unit Memory Detailed Information (H type)

Table No.	Name	Unit memory number (Hex.)			
		CH0	CH1	CH2	CH3
	Reserved for system	UM00353	UM0044D	UM00547	UM00641
5	Control code	UM00354	UM0044E	UM00548	UM00642
	Control pattern	UM00355	UM0044F	UM00549	UM00643
	Positioning acceleration time	UM00356	UM00450	UM0054A	UM00644
	Positioning deceleration time	UM00357	UM00451	UM0054B	UM00645
	Positioning target speed	UM00358 -UM00359	UM00452 -UM00453	UM0054C -UM0054D	UM00646 -UM00647
	Positioning movement amount	UM0035A -UM0035B	UM00454 -UM00455	UM0054E -UM0054F	UM00648 -UM00649
	Dwell time	UM0035C	UM00456	UM00550	UM0064A
	Reserved for system	UM0035D	UM00457	UM00551	UM0064B
6	Control code	UM0035E	UM00458	UM00552	UM0064C
	Control pattern	UM0035F	UM00459	UM00553	UM0064D
	Positioning acceleration time	UM00360	UM0045A	UM00554	UM0064E
	Positioning deceleration time	UM00361	UM0045B	UM00555	UM0064F
	Positioning target speed	UM00362 -UM00363	UM0045C -UM0045D	UM00556 -UM00557	UM00650 -UM00651
	Positioning movement amount	UM00364 -UM00365	UM0045E -UM0045F	UM00558 -UM00559	UM00652 -UM00653
	Dwell time	UM00366	UM00460	UM0055A	UM00654
	Reserved for system	UM00367	UM00461	UM0055B	UM00655
7	Control code	UM00368	UM00462	UM0055C	UM00656
	Control pattern	UM00369	UM00463	UM0055D	UM00657
	Positioning acceleration time	UM0036A	UM00464	UM0055E	UM00658
	Positioning deceleration time	UM0036B	UM00465	UM0055F	UM00659
	Positioning target speed	UM0036C -UM0036D	UM00466 -UM00467	UM00560 -UM00561	UM0065A -UM0065B
	Positioning movement amount	UM0036E -UM0036F	UM00468 -UM00469	UM00562 -UM00563	UM0065C -UM0065D
	Dwell time	UM00370	UM0046A	UM00564	UM0065E
	Reserved for system	UM00371	UM0046B	UM00565	UM0065F
8	Control code	UM00372	UM0046C	UM00566	UM00660
	Control pattern	UM00373	UM0046D	UM00567	UM00661
	Positioning acceleration time	UM00374	UM0046E	UM00568	UM00662

13.5 Unit Memory Detailed Information (H type)

Table No.	Name	Unit memory number (Hex.)			
		CH0	CH1	CH2	CH3
	Positioning deceleration time	UM00375	UM0046F	UM00569	UM00663
	Positioning target speed	UM00376 -UM00377	UM00470 -UM00471	UM0056A -UM0056B	UM00664 -UM00665
	Positioning movement amount	UM00378 -UM00379	UM00472 -UM00473	UM0056C -UM0056D	UM00666 -UM00667
	Dwell time	UM0037A	UM00474	UM0056E	UM00668
	Reserved for system	UM0037B	UM00475	UM0056F	UM00669
9	Control code	UM0037C	UM00476	UM00570	UM0066A
	Control pattern	UM0037D	UM00477	UM00571	UM0066B
	Positioning acceleration time	UM0037E	UM00478	UM00572	UM0066C
	Positioning deceleration time	UM0037F	UM00479	UM00573	UM0066D
	Positioning target speed	UM00380 -UM00381	UM0047A -UM0047B	UM00574 -UM00575	UM0066E -UM0066F
	Positioning movement amount	UM00382 -UM00383	UM0047C -UM0047D	UM00576 -UM00577	UM00670 -UM00671
	Dwell time	UM00384	UM0047E	UM00578	UM00672
	Reserved for system	UM00385	UM0047F	UM00579	UM00673
10	Control code	UM00386	UM00480	UM0057A	UM00674
	Control pattern	UM00387	UM00481	UM0057B	UM00675
	Positioning acceleration time	UM00388	UM00482	UM0057C	UM00676
	Positioning deceleration time	UM00389	UM00483	UM0057D	UM00677
	Positioning target speed	UM0038A -UM0038B	UM00484 -UM00485	UM0057E -UM0057F	UM00678 -UM00679
	Positioning movement amount	UM0038C -UM0038D	UM00486 -UM00487	UM00580 -UM00581	UM0067A -UM0067B
	Dwell time	UM0038E	UM00488	UM00582	UM0067C
	Reserved for system	UM0038F	UM00489	UM00583	UM0067D
11	Control code	UM00390	UM0048A	UM00584	UM0067E
	Control pattern	UM00391	UM0048B	UM00585	UM0067F
	Positioning acceleration time	UM00392	UM0048C	UM00586	UM00680
	Positioning deceleration time	UM00393	UM0048D	UM00587	UM00681
	Positioning target speed	UM00394 -UM00395	UM0048E -UM0048F	UM00588 -UM00589	UM00682 -UM00683

13.5 Unit Memory Detailed Information (H type)

Table No.	Name	Unit memory number (Hex.)			
		CH0	CH1	CH2	CH3
	Positioning movement amount	UM00396 -UM00397	UM00490 -UM00491	UM0058A -UM0058B	UM00684 -UM00685
	Dwell time	UM00398	UM00492	UM0058C	UM00686
	Reserved for system	UM00399	UM00493	UM0058D	UM00687
12	Control code	UM0039A	UM00494	UM0058E	UM00688
	Control pattern	UM0039B	UM00495	UM0058F	UM00689
	Positioning acceleration time	UM0039C	UM00496	UM00590	UM0068A
	Positioning deceleration time	UM0039D	UM00497	UM00591	UM0068B
	Positioning target speed	UM0039E -UM0039F	UM00498 -UM00499	UM00592 -UM00593	UM0068C -UM0068D
	Positioning movement amount	UM003A0 -UM003A1	UM0049A -UM0049B	UM00594 -UM00595	UM0068E -UM0068F
	Dwell time	UM003A2	UM0049C	UM00596	UM00690
	Reserved for system	UM003A3	UM0049D	UM00597	UM00691
13	Control code	UM003A4	UM0049E	UM00598	UM00692
	Control pattern	UM003A5	UM0049F	UM00599	UM00693
	Positioning acceleration time	UM003A6	UM004A0	UM0059A	UM00694
	Positioning deceleration time	UM003A7	UM004A1	UM0059B	UM00695
	Positioning target speed	UM003A8 -UM003A9	UM004A2 -UM004A3	UM0059C -UM0059D	UM00696 -UM00697
	Positioning movement amount	UM003AA -UM003AB	UM004A4 -UM004A5	UM0059E -UM0059F	UM00698 -UM00699
	Dwell time	UM003AC	UM004A6	UM005A0	UM0069A
	Reserved for system	UM003AD	UM004A7	UM005A1	UM0069B
14	Control code	UM003AE	UM004A8	UM005A2	UM0069C
	Control pattern	UM003AF	UM004A9	UM005A3	UM0069D
	Positioning acceleration time	UM003B0	UM004AA	UM005A4	UM0069E
	Positioning deceleration time	UM003B1	UM004AB	UM005A5	UM0069F
	Positioning target speed	UM003B2 -UM003B3	UM004AC -UM004AD	UM005A6 -UM005A7	UM006A0 -UM006A1
	Positioning movement amount	UM003B4 -UM003B5	UM004AE -UM004AF	UM005A8 -UM005A9	UM006A2 -UM006A3
	Dwell time	UM003B6	UM004B0	UM005AA	UM006A4
	Reserved for system	UM003B7	UM004B1	UM005AB	UM006A5

13.5 Unit Memory Detailed Information (H type)

Table No.	Name	Unit memory number (Hex.)			
		CH0	CH1	CH2	CH3
15	Control code	UM003B8	UM004B2	UM005AC	UM006A6
	Control pattern	UM003B9	UM004B3	UM005AD	UM006A7
	Positioning acceleration time	UM003BA	UM004B4	UM005AE	UM006A8
	Positioning deceleration time	UM003BB	UM004B5	UM005AF	UM006A9
	Positioning target speed	UM003BC -UM003BD	UM004B6 -UM004B7	UM005B0 -UM005B1	UM006AA -UM006AB
	Positioning movement amount	UM003BE -UM003BF	UM004B8 -UM004B9	UM005B2 -UM005B3	UM006AC -UM006AD
	Dwell time	UM003C0	UM004BA	UM005B4	UM006AE
	Reserved for system	UM003C1	UM004BB	UM005B5	UM006AF
16	Control code	UM003C2	UM004BC	UM005B6	UM006B0
	Control pattern	UM003C3	UM004BD	UM005B7	UM006B1
	Positioning acceleration time	UM003C4	UM004BE	UM005B8	UM006B2
	Positioning deceleration time	UM003C5	UM004BF	UM005B9	UM006B3
	Positioning target speed	UM003C6 -UM003C7	UM004C0 -UM004C1	UM005BA -UM005BB	UM006B4 -UM006B5
	Positioning movement amount	UM003C8 -UM003C9	UM004C2 -UM004C3	UM005BC -UM005BD	UM006B6 -UM006B7
	Dwell time	UM003CA	UM004C4	UM005BE	UM006B8
	Reserved for system	UM003CB	UM004C5	UM005BF	UM006B9
17	Control code	UM003CC	UM004C6	UM005C0	UM006BA
	Control pattern	UM003CD	UM004C7	UM005C1	UM006BB
	Positioning acceleration time	UM003CE	UM004C8	UM005C2	UM006BC
	Positioning deceleration time	UM003CF	UM004C9	UM005C3	UM006BD
	Positioning target speed	UM003D0 -UM003D1	UM004CA -UM004CB	UM005C4 -UM005C5	UM006BE -UM006BF
	Positioning movement amount	UM003D2 -UM003D3	UM004CC -UM004CD	UM005C6 -UM005C7	UM006C0 -UM006C1
	Dwell time	UM003D4	UM004CE	UM005C8	UM006C2
	Reserved for system	UM003D5	UM004CF	UM005C9	UM006C3
18	Control code	UM003D6	UM004D0	UM005CA	UM006C4
	Control pattern	UM003D7	UM004D1	UM005CB	UM006C5
	Positioning acceleration time	UM003D8	UM004D2	UM005CC	UM006C6

13.5 Unit Memory Detailed Information (H type)

Table No.	Name	Unit memory number (Hex.)			
		CH0	CH1	CH2	CH3
	Positioning deceleration time	UM003D9	UM004D3	UM005CD	UM006C7
	Positioning target speed	UM003DA -UM003DB	UM004D4 -UM004D5	UM005CE -UM005CF	UM006C8 -UM006C9
	Positioning movement amount	UM003DC -UM003DD	UM004D6 -UM004D7	UM005D0 -UM005D1	UM006CA -UM006CB
	Dwell time	UM003DE	UM004D8	UM005D2	UM006CC
	Reserved for system	UM003DF	UM004D9	UM005D3	UM006CD
19	Control code	UM003E0	UM004DA	UM005D4	UM006CE
	Control pattern	UM003E1	UM004DB	UM005D5	UM006CF
	Positioning acceleration time	UM003E2	UM004DC	UM005D6	UM006D0
	Positioning deceleration time	UM003E3	UM004DD	UM005D7	UM006D1
	Positioning target speed	UM003E4 -UM003E5	UM004DE -UM004DF	UM005D8 -UM005D9	UM006D2 -UM006D3
	Positioning movement amount	UM003E6 -UM003E7	UM004E0 -UM004E1	UM005DA -UM005DB	UM006D4 -UM006D5
	Dwell time	UM003E8	UM004E2	UM005DC	UM006D6
	Reserved for system	UM003E9	UM004E3	UM005DD	UM006D7
20	Control code	UM003EA	UM004E4	UM005DE	UM006D8
	Control pattern	UM003EB	UM004E5	UM005DF	UM006D9
	Positioning acceleration time	UM003EC	UM004E6	UM005E0	UM006DA
	Positioning deceleration time	UM003ED	UM004E7	UM005E1	UM006DB
	Positioning target speed	UM003EE -UM003EF	UM004E8 -UM004E9	UM005E2 -UM005E3	UM006DC -UM006DD
	Positioning movement amount	UM003F0 -UM003F1	UM004EA -UM004EB	UM005E4 -UM005E5	UM006DE -UM006DF
	Dwell time	UM003F2	UM004EC	UM005E6	UM006E0
	Reserved for system	UM003F3	UM004ED	UM005E7	UM006E1

13.6 Dimensions

13.6 Dimensions

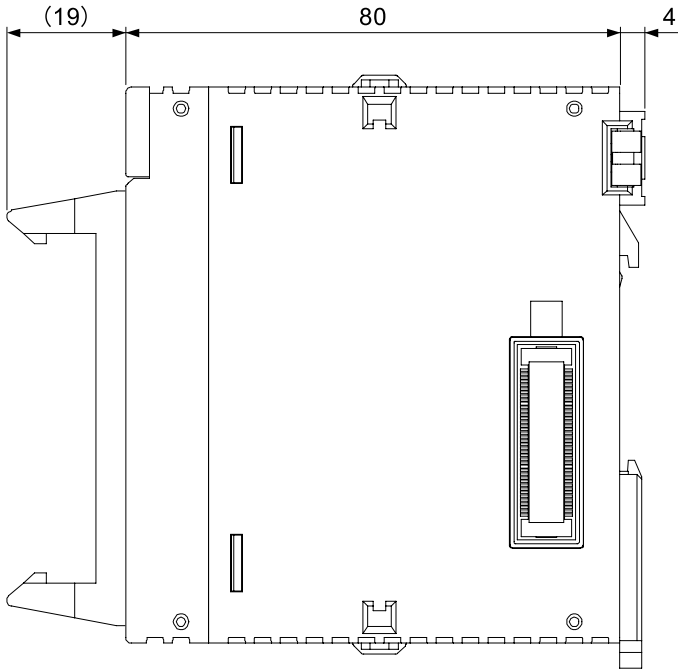
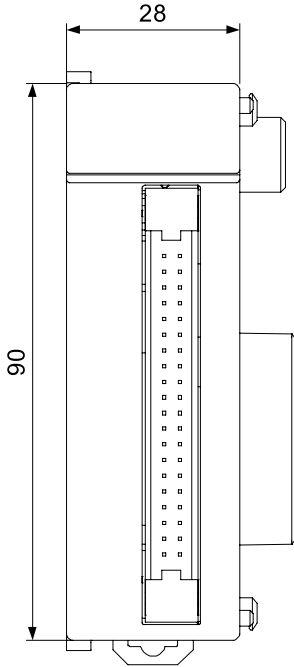

(Unit: mm)

Record of changes

Manual numbers can be found at the bottom of the manual cover.

Date	Manual No.	Record of Changes
Apr. 2016	WUME-FP7MXY-01	1st Edition
Apr. 2016	-	- Error correction <ul style="list-style-type: none"> ● Corrected terminal layout diagram and external connection diagram (Section 3.1.2) ● Correction common method for input specifications (Section 3.1.3) ● Corrected other errors.
Sep. 2016	WUME-FP7MXY-02	2nd Edition Added model <ul style="list-style-type: none"> ● H type AFP7MXY32DWDH Added functions <ul style="list-style-type: none"> ● Added Interrupt Start Condition ● Added Pulse Output Start Logic ● Added error annunciation specifications
Jun. 2022	WUME-FP7MXY-04	4th Edition Changed manual format
May 2023	WUME-FP7MXY-05	5th Edition Add Push-In Connector "3.4.1 About Push-In Connector"
Apr. 2024	WUME-FP7MXY-06	6th Edition Change in Corporate name

Order Placement Recommendations and Considerations

The Products and Specifications listed in this document are subject to change (including specifications, manufacturing facility and discontinuing the Products) as occasioned by the improvements of Products. Consequently, when you place orders for these Products, Panasonic Industry Co., Ltd. asks you to contact one of our customer service representatives and check that the details listed in the document are commensurate with the most up-to-date information.

[Safety precautions]

Panasonic Industry Co., Ltd. is consistently striving to improve quality and reliability. However, the fact remains that electrical components and devices generally cause failures at a given statistical probability. Furthermore, their durability varies with use environments or use conditions. In this respect, check for actual electrical components and devices under actual conditions before use. Continued usage in a state of degraded condition may cause the deteriorated insulation. Thus, it may result in abnormal heat, smoke or fire. Carry out safety design and periodic maintenance including redundancy design, design for fire spread prevention, and design for malfunction prevention so that no accidents resulting in injury or death, fire accidents, or social damage will be caused as a result of failure of the Products or ending life of the Products.

The Products are designed and manufactured for the industrial indoor environment use. Make sure standards, laws and regulations in case the Products are incorporated to machinery, system, apparatus, and so forth. With regard to the mentioned above, confirm the conformity of the Products by yourself.

Do not use the Products for the application which breakdown or malfunction of Products may cause damage to the body or property.

- i) usage intended to protect the body and ensure security of life
- ii) application which the performance degradation or quality problems, such as breakdown, of the Products may directly result in damage to the body or property

It is not allowed the use of Products by incorporating into machinery and systems indicated below because the conformity, performance, and quality of Products are not guaranteed under such usage.

- i) transport machinery (cars, trains, boats and ships, etc.)
- ii) control equipment for transportation
- iii) disaster-prevention equipment / security equipment
- iv) control equipment for electric power generation
- v) nuclear control system
- vi) aircraft equipment, aerospace equipment, and submarine repeater
- vii) burning appliances
- viii) military devices
- ix) medical devices (except for general controls)
- x) machinery and systems which especially require the high level of reliability and safety

[Acceptance inspection]

In connection with the Products you have purchased from us or with the Products delivered to your premises, please perform an acceptance inspection with all due speed and, in connection with the handling of our Products both before and during the acceptance inspection, please give full consideration to the control and preservation of our Products.

[Warranty period]

Unless otherwise stipulated by both parties, the warranty period of our Products is three years after the purchase by you or after their delivery to the location specified by you. The consumable items such as battery, relay, filter and other supplemental materials are excluded from the warranty.

[Scope of warranty]

In the event that Panasonic Industry Co., Ltd. confirms any failures or defects of the Products by reasons solely attributable to Panasonic Industry Co., Ltd. during the warranty period, Panasonic Industry Co., Ltd. shall supply the replacements of the Products, parts or replace and/or repair the defective portion by free of charge at the location where the Products were purchased or delivered to your premises as soon as possible.

However, the following failures and defects are not covered by warranty and we are not responsible for such failures and defects.

- (1) When the failure or defect was caused by a specification, standard, handling method, etc. which was specified by you.
- (2) When the failure or defect was caused after purchase or delivery to your premises by an alteration in construction, performance, specification, etc. which did not involve us.
- (3) When the failure or defect was caused by a phenomenon that could not be predicted by the technology at purchasing or contracted time.
- (4) When the use of our Products deviated from the scope of the conditions and environment set forth in the instruction manual and specifications.
- (5) When, after our Products were incorporated into your products or equipment for use, damage resulted which could have been avoided if your products or equipment had been equipped with the functions, construction, etc. the provision of which is accepted practice in the industry.
- (6) When the failure or defect was caused by a natural disaster or other force majeure.
- (7) When the equipment is damaged due to corrosion caused by corrosive gases etc. in the surroundings.

The above terms and conditions shall not cover any induced damages by the failure or defects of the Products, and not cover your production items which are produced or fabricated by using the Products. In any case, our responsibility for compensation is limited to the amount paid for the Products.

[Scope of service]

The cost of delivered Products does not include the cost of dispatching an engineer, etc. In case any such service is needed, contact our sales representative.

Panasonic Industry Co., Ltd.

105-FADB-04(R1)

WUME-FP7MX-06

(MEMO)

Panasonic Industry Co., Ltd.

1006, Oaza Kadoma, Kadoma-shi, Osaka 571-8506, Japan
<https://industry.panasonic.com/>

Please visit our website for inquiries and about our sales network.

© Panasonic Industry Co., Ltd. 2016-2024

April, 2024

WUME-FP7MXY-06