

PROGRAMMABLE CONTROLLER
FP0R Analog I/O Unit
User's Manual

[Applicable Models]

- FP0R Analog Input Unit (Model No. AFP0RAD4/AFP0RAD8)
- FP0R Analog Output Unit (Model No. AFP0RDA4)
- FP0R Analog I/O Unit (Model No. AFP0RA21/AFP0RA42)

Safety Precautions

Observe the following notices to ensure personal safety or to prevent accidents.
To ensure that you use this product correctly, read this User's Manual thoroughly before use.
Make sure that you fully understand the product and information on safety.
This manual uses two safety flags to indicate different levels of danger.

WARNING

If critical situations that could lead to user's death or serious injury is assumed by mishandling of the product.

- Always take precautions to ensure the overall safety of your system, so that the whole system remains safe in the event of failure of this product or other external factor.
- Do not use this product in areas with inflammable gas. It could lead to an explosion.
- Exposing this product to excessive heat or open flames could cause damage to the lithium battery or other electronic parts.

CAUTION

If critical situations that could lead to user's injury or only property damage is assumed by mishandling of the product.

- To prevent excessive exothermic heat or smoke generation, use this product at the values less than the maximum of the characteristics and performance that are assured in these specifications.
- Do not dismantle or remodel the product. It could cause excessive exothermic heat or smoke generation.
- Do not touch the terminal while turning on electricity. It could lead to an electric shock.
- Use the external devices to function the emergency stop and interlock circuit.
- Connect the wires or connectors securely.
The loose connection could cause excessive exothermic heat or smoke generation.
- Do not allow foreign matters such as liquid, flammable materials, metals to go into the inside of the product. It could cause excessive exothermic heat or smoke generation.
- Do not undertake construction (such as connection and disconnection) while the power supply is on. It could lead to an electric shock.

Copyright / Trademarks

- This manual and its contents are copyrighted.
- You may not copy this manual, in whole or part, without written consent of Panasonic Industry Co., Ltd.
- Windows is a registered trademark of Microsoft Corporation in the United States and other countries.
- All other company names and product names are trademarks or registered trademarks of their respective owners.

PLC_ORG

Introduction

Thank you for buying a Panasonic product. Before you use the product, please carefully read the installation instructions and the users manual, and understand their contents in detail to use the product properly.

Types of Manual

- There are different types of users manual for the FP0R series, as listed below. Please refer to a relevant manual for the unit and purpose of your use.
- The manuals can be downloaded on our website:
<https://industry.panasonic.com/global/en/downloads/?tab=manual>

Unit name or purpose of use	Manual name	Manual code
FP0R Control Unit	FP0R User's Manual	ARCT1F475E
FP0R Expansion I/O Unit		
FPΣ Control Unit	FPΣ User's Manual	ARCT1F333E
FP0H Control Unit	FP0H User's Manual (Basic)	WUME-FP0HBAS
FP0R Analog Input Unit	FP0R Analog I/O Unit User's Manual	WUME-FP0RAIO
FP0R Analog Output Unit		
FP0R Analog I/O Unit		
Programming	FP-series Programming Manual	ARCT1F313E
Programming Software FPWIN GR	FPWIN GR Operation Guide (Non-free)	ARCT1F332E

Table of Contents

1. Unit Functions and Restrictions	1-1
1.1 Unit Functions and How They Work	1-2
1.1.1 Functions of Unit	1-2
1.1.2 Unit Type	1-2
1.1.3 Restrictions on Units Combination	1-2
2. Names and Functions of Parts	2-1
2.1 Analog Input Unit (FP0R-AD4/AD8).....	2-2
2.1.1 Names and Functions of Parts	2-2
2.1.2 Setting of Mode Switch.....	2-3
2.2 Analog Output Unit (FP0R-DA4).....	2-4
2.2.1 Names and Functions of Parts	2-4
2.2.2 Setting of Mode Switch.....	2-5
2.3 Analog I/O Unit (FP0R-A21/A42).....	2-6
2.3.1 Names and Functions of Parts	2-6
2.3.2 Setting of Mode Switch.....	2-7
3. Wiring	3-1
3.1 Analog Input Unit (FP0R-AD4/AD8).....	3-2
3.1.1 Terminal Layout Diagrams	3-2
3.1.2 Wiring of Analog Input Unit.....	3-3
3.2 Analog Output Unit (FP0R-DA4).....	3-4
3.2.1 Terminal Layout Diagrams	3-4
3.2.2 Wiring of Analog Output Unit.....	3-5
3.3 Analog I/O Unit (FP0R-A21/A42).....	3-6
3.3.1 Terminal Layout Diagrams	3-6
3.3.2 Wiring of Analog I/O Unit.....	3-7

3.4	Common Precautions.....	3-8
3.4.1	Wiring of Analog I/O Unit.....	3-8
3.4.2	Wiring of Power Cable (FP0R-DA4 / FP0R-A21 / FP0R-A42).....	3-9
4.	Creating Programs	4-1
4.1	I/O Allocation	4-2
4.1.1	I/O Allocation	4-2
4.2	Analog input unit (FP0R-AD4/AD8).....	4-4
4.2.1	Reading of Input Data (Common to 12-bit Mode and 14-bit Mode).....	4-4
4.2.2	Setting of Input Range and Averaging Processing (14-bit Mode Only) ..	4-6
4.3	Analog Output Unit (FP0R-DA4)	4-8
4.3.1	Writing of Digital Data for Output (12-bit Mode).....	4-8
4.3.2	Writing of Digital Data for Output (14-bit Mode).....	4-14
4.3.3	Switching of Output Range (14-bit Mode Only)	4-20
4.3.4	Status Information (12-bit mode).....	4-22
4.3.5	Status information (14-bit mode).....	4-23
4.4	Analog I/O Unit (FP0R-A21/A42)	4-24
4.4.1	Reading of Analog Input Values (For A21)	4-24
4.4.2	Reading of Analog Input Values (For A42)	4-25
4.4.3	Writing of Digital Data for Output (12-bit Mode).....	4-28
4.4.4	Writing of Digital Data for Output (14-bit Mode).....	4-30
4.4.5	Switching of Input Range and Averaging Method (14-bit Mode Only) ..	4-32
4.4.6	Switching of Output Range (14-bit Mode Only)	4-34
4.5	I/O Conversion Characteristics.....	4-36
4.5.1	Input Conversion Characteristics (Voltage Range).....	4-36
4.5.2	Input conversion Characteristics (Current Range).....	4-39
4.5.3	Output conversion Characteristics (Voltage Range).....	4-40
4.5.4	Output conversion Characteristics (Current Range).....	4-42
5.	Analog Input Averaging Processing	5-1
5.1	Types of Averaging Processing.....	5-2

- 5.1.1 Moving Average 10 Times.....5-2
- 5.1.2 Number of Averaging Times (64 times/128 times: 14-bit Mode Only)5-3
- 5.2 Setting of Averaging Processing.....5-4
 - 5.2.1 Enabling Averaging Processing5-4
- 6. Specifications 6-1**
 - 6.1 Table of Specifications6-2
 - 6.1.1 General Specifications6-2
 - 6.1.2 Input Specifications6-3
 - 6.1.3 Output Specifications6-4
 - 6.2 Dimension6-5
- 7. Compatibility with Conventional Models 7-1**
 - 7.1 Analog Input Unit.....7-2
 - 7.1.1 Compatibility with Conventional Models.....7-2
 - 7.1.2 Points of Replacement7-3
 - 7.2 Analog Output Unit7-4
 - 7.2.1 Compatibility with Conventional Models.....7-4
 - 7.2.2 Points of Replacement7-5
 - 7.3 Analog I/O Unit7-6
 - 7.3.1 Compatibility with Conventional Models.....7-6
 - 7.3.2 Points of Replacement7-7

1

Unit Functions and Restrictions

1.1 Unit Functions and How They Work

1.1.1 Functions of Unit

- **Attaching these units to FP0R Control Unit enables analog I/O control.**
- It is selectable from five types of units in accordance with the intended use.
- **Compatibility mode with conventional models is prepared.**
- The compatibility mode which enables smooth transition from conventional Analog I/O Units (FP0-A80, FP0-A04V, FP0-A04I, FP0-A21) is prepared.
- **14-bit processing mode is added.**
- The high-resolution 14-bit mode (1/16000) is added to the both input and output. Also, ranges for each channel can be specified by user programs.

1.1.2 Unit Type

Name	Specifications	Product number
FP0R Analog Input unit	4-ch input	AFP0RAD4
	8-ch input	AFP0RAD8
FP0R Analog Output Unit	4-ch output	AFP0RDA4
FP0R Analog I/O Unit	2-ch Input, 1-ch output	AFP0RA21
	4-ch Input, 2-ch output	AFP0RA42

1.1.3 Restrictions on Units Combination

Up to three units can be connected with the control unit including other FP0/FP0R Expansion I/O Unit and intelligent unit.

2

Names and Functions of Parts

2.1 Analog Input Unit (FP0R-AD4/AD8)

2.1.1 Names and Functions of Parts

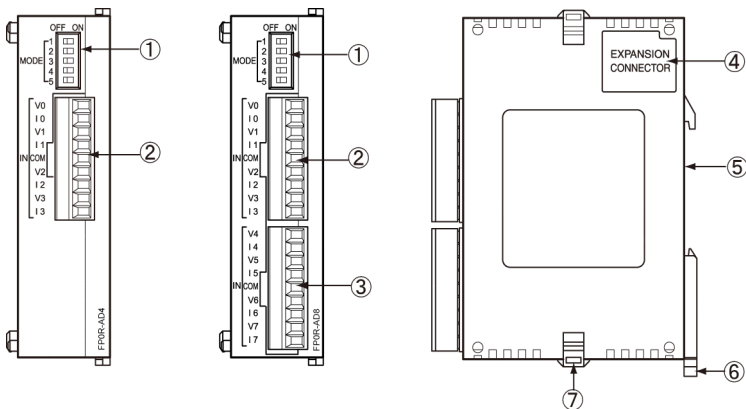

■ Names and Functions of Parts

No.	Name	Description
①	Mode setting switch	<ul style="list-style-type: none"> Used for selecting the input range, the number of input channels and whether to use the averaging processing or not. Used for selecting the operation mode (12-bit mode or 14-bit mode compatible with the conventional product FP0-A80).
②	Input terminal for CH0-CH3	Used for connecting the analog input device.
③	Input terminal for CH4-CH7	Used for connecting the analog input device.
④	Expansion connector	Used for connecting the expansion unit with the internal circuit of the Control Unit.
⑤	DIN rail installing groove	It can be installed to a 35-mm-wide DIN rail.
⑥	DIN hook	The unit can be installed to the DIN rail through one-touch operation. This hook is also used for installing the unit to the Slim Type Mounting Plate (AFP0803).
⑦	Expansion hook	Used for securing expansion units.

2.1.2 Setting of Mode Switch

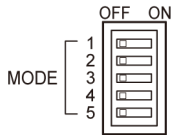

■ Setting of the mode switch

Item	No.	Settings			
Resolution and FP0-A21-compatible 12-bit mode input range	1	OFF	ON	OFF	ON
	2	OFF	OFF	ON	ON
		FP0-A80-compatible 12-bit mode 0 to 5V/0 to 20mA (Note 1)	FP0-A80-compatible 12-bit mode -10 to +10V	FP0-A80-compatible 12-bit mode -100 to +100mV (Note 2)	14-bit mode (Note 3)
The number of converted CH	3	OFF	ON	OFF	ON
	4	OFF	OFF	ON	ON
		2ch (CH0-CH1)	4ch (CH0-CH3)	6ch (CH0-CH5)	8ch (CH0-CH7)
Input averaging	5	OFF: Averaging Not performed, ON: Averaging Performed			

(Note 1): When the both switch No.1 and No.2 are OFF, the voltage/current is switched by the connection method.

(Note 2): This has been implemented in version 1.2 or later. In version 1.1 or earlier, this is reserved for the system (not available).

(Note 3): In the 14-bit mode, the input range is set by writing into the operation memory WY with a user program.

(Note 4): All the switches are set to OFF at the factory.

(Note 5): The switch settings will be valid when the power is turned ON from OFF. The settings will not change if the operation power supply is switched when it is ON.

2.2 Analog Output Unit (FP0R-DA4)

2.2.1 Names and Functions of Parts

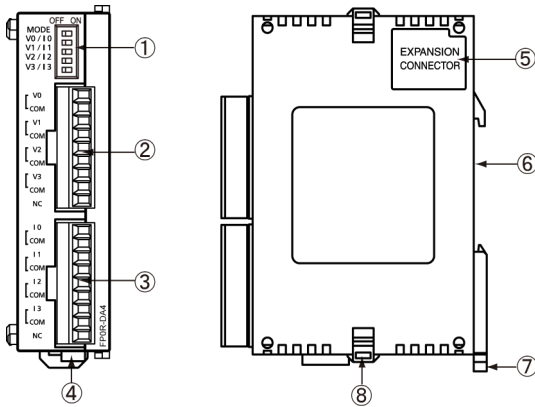

■ Names and Functions of Parts

No.	Name	Description
①	Mode setting switch	<ul style="list-style-type: none"> Used for selecting the output range and the output method (voltage/current). Used for selecting the operation mode (12-bit mode or 14-bit mode compatible with the conventional product FP0-A04V/A04I).
②	Voltage output terminal for CH0-CH3	<ul style="list-style-type: none"> Used for connecting the analog output device. The voltage and current vary according to the settings of the mode switch. They can be selected for each channel.
③	Current output terminal for CH0-CH3	
④	Power connector	24 V DC is supplied from an external power supply. For connection, use the power supply cable (AFP0581) that comes with the Unit.
⑤	Expansion connector	Used for connecting the expansion unit with the internal circuit of the Control Unit.
⑥	DIN rail installing groove	It can be installed to a 35-mm-wide DIN rail.
⑦	DIN hook	The unit can be installed to the DIN rail through one-touch operation. This hook is also used for installing the unit to the Slim Type Mounting Plate (AFP0803).
⑧	Expansion hook	Used for securing expansion units.

2.2.2 Setting of Mode Switch

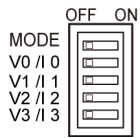

■ Setting of the mode switch

Item	No.	Settings
Resolution	1	OFF : FP0-A04V/A04I compatible 12-bit mode, ON : 14-bit mode (Note 1)
Output switch	2	CH0
	3	CH1
	4	CH2
	5	CH3
		OFF : Voltage output ON : Current output (Note 2)

(Note 1): In the 14-bit mode, the output range is set by writing into the operation memory WY with a user program.

(Note 2): For the both FP0-A04V/A04I compatibility 12-bit mode and 14-bit mode, the output can be selected for each channel.

(Note 3): All the switches are set to OFF at the factory.

(Note 4): The switch settings will be valid when the power is turned ON from OFF. The settings will not change if the operation power supply is switched when it is ON.



◆ KEY POINTS

- In the FP0-A04V/A04I compatibility 12-bit mode, the voltage output range is -10 to +10 V, and the current output range is 4 to 20 mA.

2.3 Analog I/O Unit (FP0R-A21/A42)

2.3.1 Names and Functions of Parts

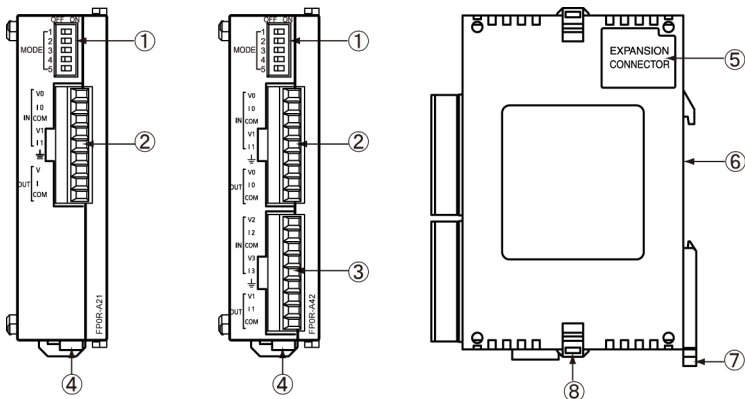

■ Names and Functions of Parts

No.	Name	Description
①	Mode setting switch	<ul style="list-style-type: none"> Used for selecting the input and output ranges, the output method (voltage/current), and whether to perform the input averaging processing or not. Used for selecting the operation mode (12-bit mode or 14-bit mode compatible with the conventional product FP0-A21).
②	I/O terminal Input for CH0-CH1 Output for CH0	<ul style="list-style-type: none"> Used for connecting the analog input device or analog output device. The voltage and current vary according to the settings of the mode switch. They can be selected for each channel.
③	I/O terminal Input for CH2-CH3 Output for CH1	
④	Power connector	The supply 24 V DC from an external power supply. For connection, use the power supply cable (AFP0581) that comes with the Unit.
⑤	Expansion connector	Used for connecting the expansion unit with the internal circuit of the Control Unit.
⑥	DIN rail installing groove	It can be installed to a 35-mm-wide DIN rail.
⑦	DIN hook	The unit can be installed to the DIN rail through one-touch operation. This hook is also used for installing the unit to the Slim Type Mounting Plate (AFP0803).
⑧	Expansion hook	Used for securing expansion units.

2.3.2 Setting of Mode Switch

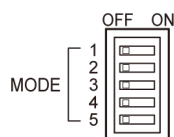

■ Setting of the mode switch

Item	No.	Settings			
I/O resolution and FP0-A21-compatible 12-bit mode input range	1	OFF	ON	OFF	ON
	2	OFF	OFF	ON	ON
		FP0-A21-compatible 12-bit mode 0 to 5V/0 to 20mA (Note 1)	FP0-A21-compatible 12-bit mode -10 to +10V	Reserved for system (Not settable)	14-bit mode (Note 2)
FP0-A21-compatible 12-bit mode output range (Note 3)	3	OFF	ON	OFF	ON
	4	OFF	OFF	ON	ON
		FP0-A21-compatible 12-bit mode 0 to 20mA	Reserved for system (Not settable)	FP0-A21-compatible 12-bit mode -10 to +10V	Reserved for system (Not settable)
14-bit mode output switch (Note 4)	3	OFF	ON	OFF	ON
	4	OFF	OFF	ON	ON
		CH0 Voltage output CH1 Voltage output	CH0 Current output CH1 Voltage output	CH0 Voltage output CH1 Current output	CH0 Current output CH1 Current output
Input averaging	5	OFF: Averaging Not performed, ON: Averaging Performed			

(Note 1): When the both switch No.1 and No.2 are OFF, the input voltage/current is switched by the connection method.

(Note 2): In the 14-bit mode, the input and output ranges are set by writing into the operation memory WY with a user program.

(Note 3): The setting of "FP0-A21 compatibility 12-bit mode output switch" of the switches No.3 and No.4 is valid when the switch No.2 is off.

(Note 4): The setting of "14-bit mode output switch" of the switches No.3 and No.4 is valid when the both switch No.1 and No.2 are on. Switching CH1 is available only for A42 type.

(Note 5): All the switches are set to OFF at the factory.

(Note 6): The switch settings will be valid when the power is turned ON from OFF. The settings will not change if the operation power supply is switched when it is ON.

3

Wiring

3.1.2 Wiring of Analog Input Unit

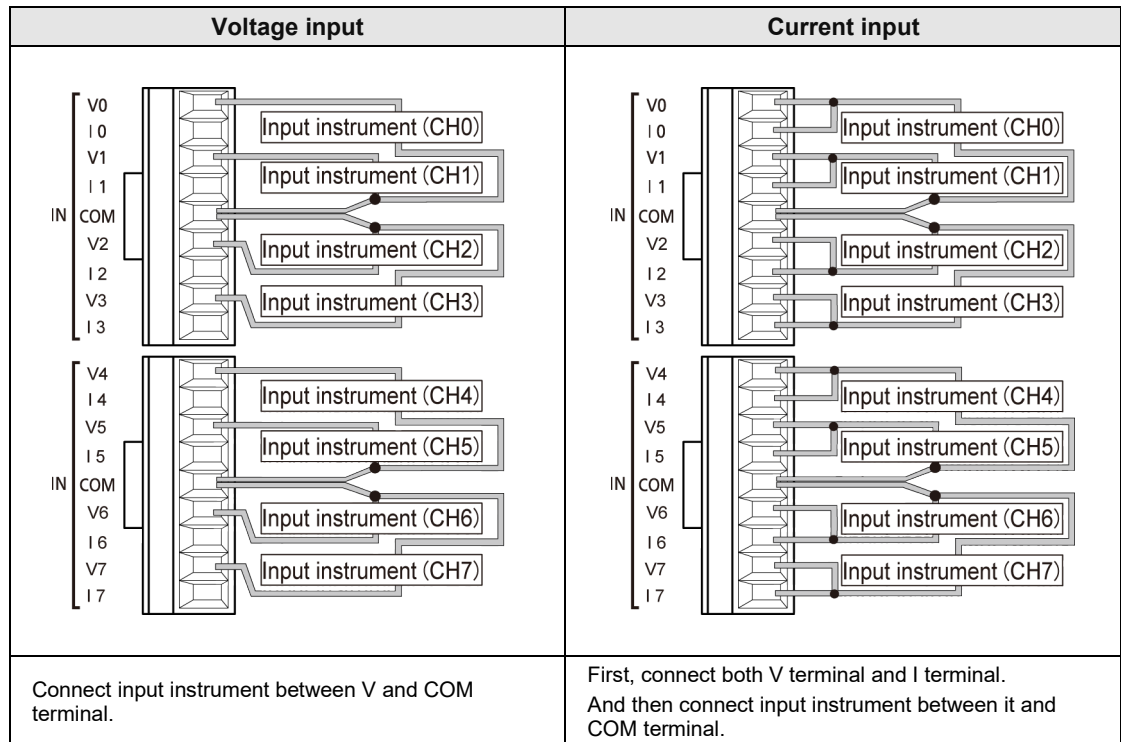

(Note 1): Two COM terminals are connected internally.

(Note 2): Two cables or less must be inserted to COM terminal as above (two channel once combined).

(Note 3): Recommend using the twisted and shielded communication cables for analog lines and grounding the end of shield.

3.2.2 Wiring of Analog Output Unit

■ When the voltage output

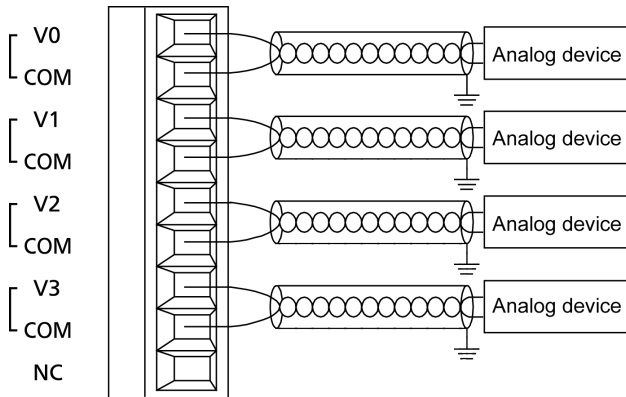

■ When current output

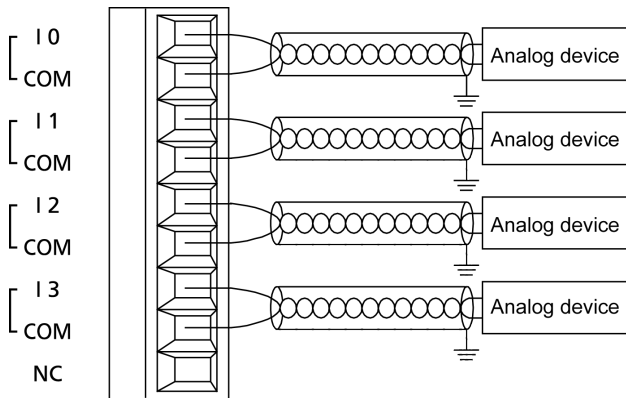

(Note): All COM terminals of the voltage output terminal block and current output terminal block are connected internally.

3.3 Analog I/O Unit (FP0R-A21/A42)

3.3.1 Terminal Layout Diagrams



Appearance	Pin No.	Name		Function			
	1	IN	V0	Analog input	CH0	Voltage signal input	
	2	IN	I0		CH0	Current signal input	
	3	IN	COM		---	Input common	
	4	IN	V1		CH1	Voltage signal input	
	5	IN	I1		CH1	Current signal input	
	6	FG		For shield connection of analog signal cable			
	7	OUT	V0	Analog output	CH0	Voltage signal output	
	8	OUT	I0		CH0	Current signal output	
	9	OUT	COM		---	Output common	
	Pin No. Name Function						
	1	IN	V0	Analog input	CH2	Voltage signal input	
	2	IN	I0		CH2	Current signal input	
	3	IN	COM		---	Input common	
	4	IN	V1		CH3	Voltage signal input	
	5	IN	I1		CH3	Current signal input	
6	FG		For shield connection of analog signal cable				
7	OUT	V1	Analog output	CH1	Voltage signal output		
8	OUT	I1		CH1	Current signal output		
9	OUT	COM		---	Output common		

(Note 1): For inputting a current signal to the analog input part, connect the V terminal and I terminal externally.

(Note 2): All COM terminals are connected within the unit.

3.3.2 Wiring of Analog I/O Unit

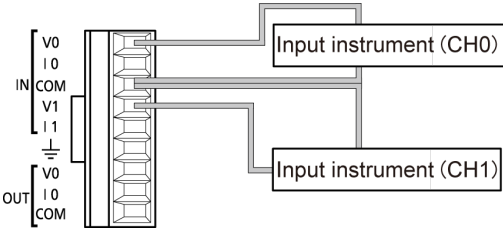
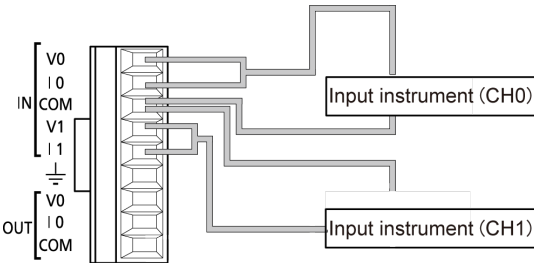
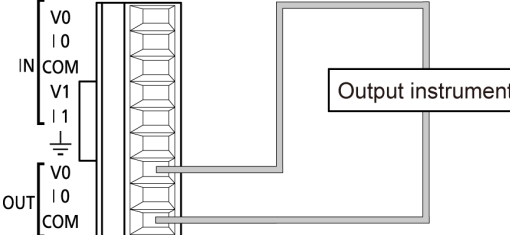
■ Analog input

Voltage input	Current input
	
<p>Connect input instrument between IN/V and IN/COM terminal.</p>	<p>First, connect both IN/V terminal and IN/I terminal. And then connect input instrument between it and IN/COM terminal.</p>
Voltage output	Current output
	
<p>Connect output instrument between OUT/V and OUT/COM terminal.</p>	<p>Connect output instrument between OUT/I and OUT/COM terminal.</p>

(Note 1): In the above figure, the input (CH0/CH1) and output CH0 are described as representative examples.

The input (CH2/CH3) and output CH1 of A42 type also have the same terminal layouts.

(Note 2): All COM terminals are connected within the unit.

3.4 Common Precautions

3.4.1 Wiring of Analog I/O Unit

■ **Wiring diagram**

Voltage input

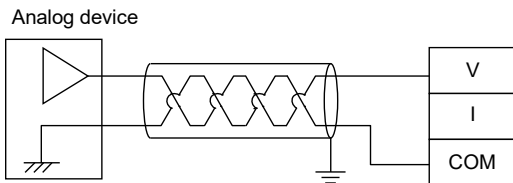

Current input

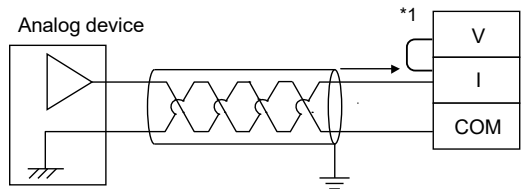

*1: For the current input, short-circuit the V and I terminals.

Voltage output

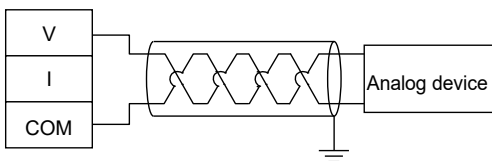

Current output

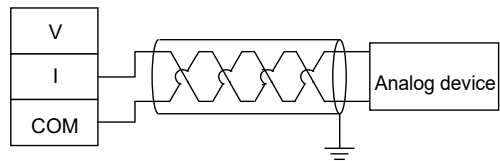

■ **Precautions on Wiring**

- Use double-core twisted-pair shielded wires. It is recommended to ground the shielding. However, depending on the conditions of the external noise, it may be better not to ground the shielding.
- Do not have the analog input wiring close to AC wires, power wires, or load wires.
- Do not have the analog output wiring close to AC wires, power wires, or load wires.

■ **Compatible cable (twisted wire)**

Size	Nominal cross section area
AWG#28-16	0.08 mm ² -1.25 mm ²

■ **Special tools**

Manufacturer	Serial number (model number)
Phoenix Contact Co.	SZS0.4×2.5(1205037)

3.4.2 Wiring of Power Cable (FP0R-DA4 / FP0R-A21 / FP0R-A42)

The power needs to be supplied to the analog output unit (FP0R-DA4) and analog I/O unit (FP0R-A21/FP0R-A42) for operation.

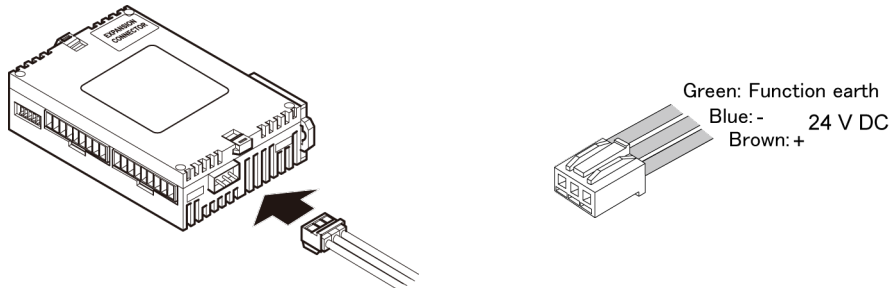

■ Precautions on Wiring

- It is connected using the cable (Part number:AFP0581) supplied with the unit.
- The input voltage range of the power supply for operating the unit is 20.4 to 28.8 VDC.
- Use the power supply of SELV (Safety Extra-Low Voltage) and LIM (Limited Energy Circuit).
- In order to avoid influence of noise, the function earth terminal must be grounded.

4

Creating Programs

4.1 I/O Allocation

4.1.1 I/O Allocation

- For analog input data and analog output data, input relays (WX) and output relays (WY) are read and written to the control unit.
- I/O numbers do not need to be set as I/O allocation is performed automatically.
- I/O numbers vary according to installation positions.
- The allocated contents vary according to the type of units and mode. For details, refer to the chapters 4.2 to 4.4.

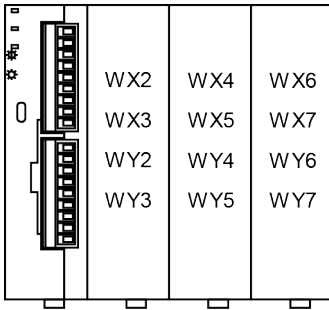

Type of unit	Allocation content	I/O number		
		Expansion unit 1	Expansion unit 2	Expansion unit 3
FP0R Analog input unit AFP0RAD4 (Note 1) AFP0RAD8	Input CH0/CH2/CH4/CH6	WX2 (X20~X2F)	WX4 (X40~X4F)	WX6 (X60~X6F)
	Input CH1/CH3/CH5/CH7	WX3 (X30~X3F)	WX5 (X50~X5F)	WX7 (X70~X7F)
	Output 14-bit mode range setting	WY2 (Y20~Y2F)	WY4 (Y40~Y4F)	WY6 (Y60~Y6F)
	Output 14-bit mode range averaging setting	WY3 (Y30~Y3F)	WY5 (Y50~Y5F)	WY7 (Y70~Y7F)
FP0R Analog output unit AFP0RDA4	Input Status information (Power ON/OFF, Write state)	WX2 (X20~X2F)	WX4 (X40~X4F)	WX6 (X60~X6F)
		WX3 (X30~X3F)	WX5 (X50~X5F)	WX7 (X70~X7F)
	Output (Note 2) CH0/CH2	WY2 (Y20~Y2F)	WY4 (Y40~Y4F)	WY6 (Y60~Y6F)
	Output (Note 2) CH1/CH3	WY3 (Y30~Y3F)	WY5 (Y50~Y5F)	WY7 (Y70~Y7F)
FP0R Analog I/O unit AFP0RA21 (Note 3) AFP0RA42	Input CH0/CH2	WX2 (X20~X2F)	WX4 (X40~X4F)	WX6 (X60~X6F)
	Input CH1/CH3	WX3 (X30~X3F)	WX5 (X50~X5F)	WX7 (X70~X7F)
	Output (Note 4) CH0	WY2 (Y20~Y2F)	WY4 (Y40~Y4F)	WY6 (Y60~Y6F)
	Output (Note 4) CH1	WY3 (Y30~Y3F)	WY5 (Y50~Y5F)	WY7 (Y70~Y7F)

(Note 1):On AFP0RAD4, data of CH0 to CH3 is handled.

(Note 2):It can be also used for switching the output range in the 14-bit mode.

(Note 3):On AFP04A21, data of input CH0/CH1 and output CH0 is handled.

(Note 4):It can be also used for the input range, averaging setting for input and switching the output range in the 14-bit mode.

4.2 Analog input unit (FP0R-AD4/AD8)

4.2.1 Reading of Input Data (Common to 12-bit Mode and 14-bit Mode)

The analog input unit uses the most significant 2 bits as a flag for switching channels and reads conversion data sequentially.

■ I/O allocation (External input WX)

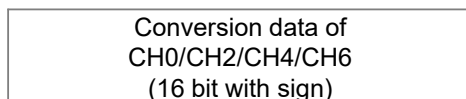
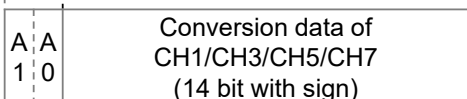
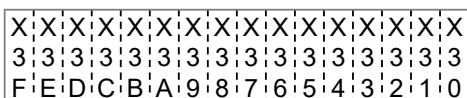

Conversion data switch flag

A1	A0	WX3	WX2
0	0	CH1 data	CH0 data
0	1	CH3 data	CH2 data
1	0	CH5 data	CH4 data
1	1	CH7 data	CH6 data

■ Role of conversion data switching flag

- The analog input unit reads the analog input data of a maximum of 8 channels using two memory areas (WX2 and WX3). The most significant two bits are allocated as a conversion data switching flag for distinguishing channels.
- Conversion data of even numbered channels can be read as 16-bit data as they are.
- As conversion data of odd numbered channels contain the conversion data switching flag of most significant two bits, mask processing needs to be applied to the data with a user program. Plus conversion data should be masked by "00", and minus conversion data should be masked by "11". Create a program in reference to the following programs.

(Example):For reading data of CH3

CH3 data	WX3	Data after masking	Description
1	0100 0000 0000 0001	0000 0000 0000 0001	Most significant two bits are masked by "00".
-1	0111 1111 1111 1111	1111 1111 1111 1111	Most significant two bits are masked by "11".

■ **Sample program (Analog input: For ranges of -10 V to +10 V and -5 V to +5 V)**

The following program shows the case that conversion data of the first expansion analog input unit (CH0 to CH7) is read and stored in DT0 to DT7.

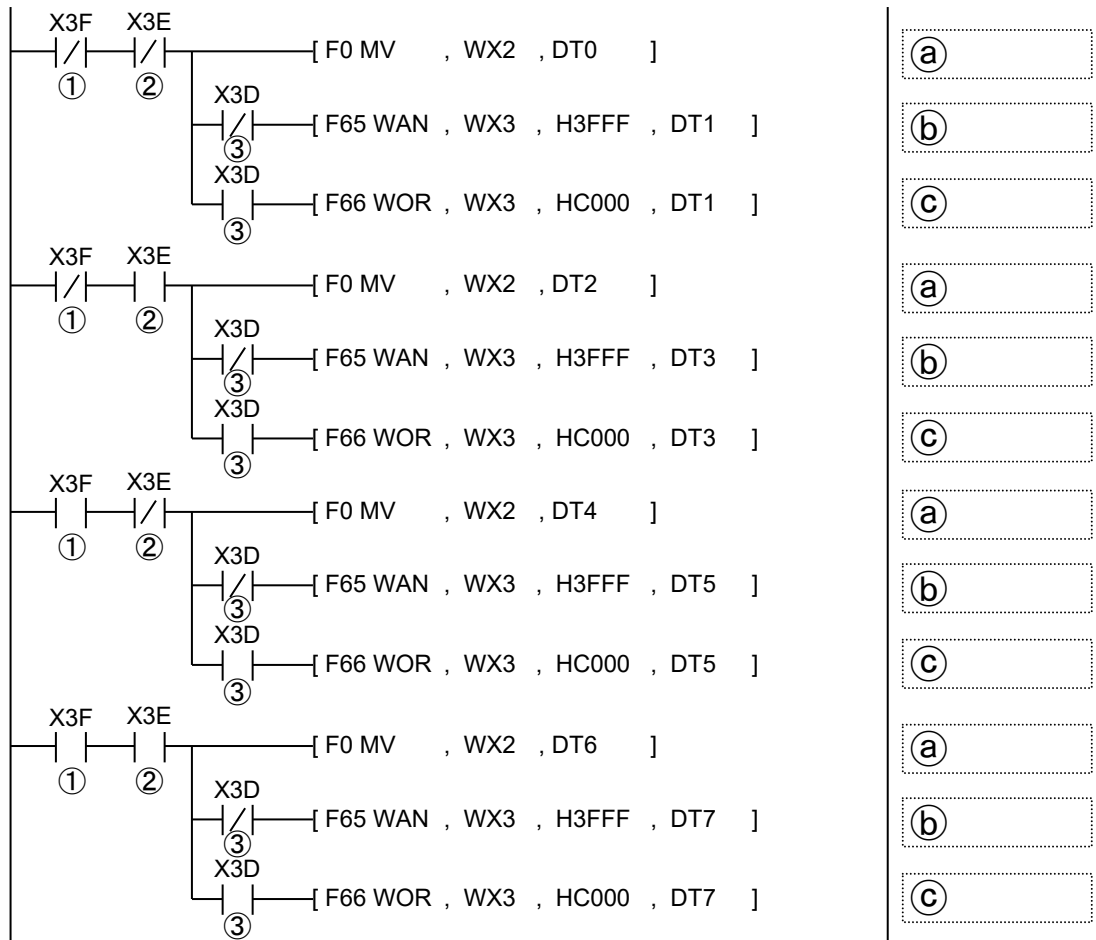

①	X3F	The channels of conversion data read by turning on/off the conversion data switching flags X3F and X3E are distinguished.
②	X3E	
③	X3D	The signs of conversion data of read odd numbered channels are distinguished. When plus, OFF. When minus, ON.
(a)	Conversion data of even numbered channels CH0/CH2/CH4/CH6 is transferred as is.	
(b)	When the data of odd numbered channels CH1/CH3/CH5/HC7 is positive, the most significant two bits are masked by "00" with F65 WAN (AND) instruction, and the data is stored in DT1/DT3/DT5/DT7.	
(c)	When the data of odd numbered channels CH1/CH3/CH5/HC7 is negative, the most significant two bits are masked by "11" with F66 WOR (OR) instruction, and the data is stored in DT1/DT3/DT5/DT7.	

■ **Sample program (For ranges of 0 to 10 V, 0 to 5 V and 0 to 20 mA)**

The following program shows the case that conversion data of the first expansion analog input unit (CH0 to CH7) is read and stored in DT0 to DT7.

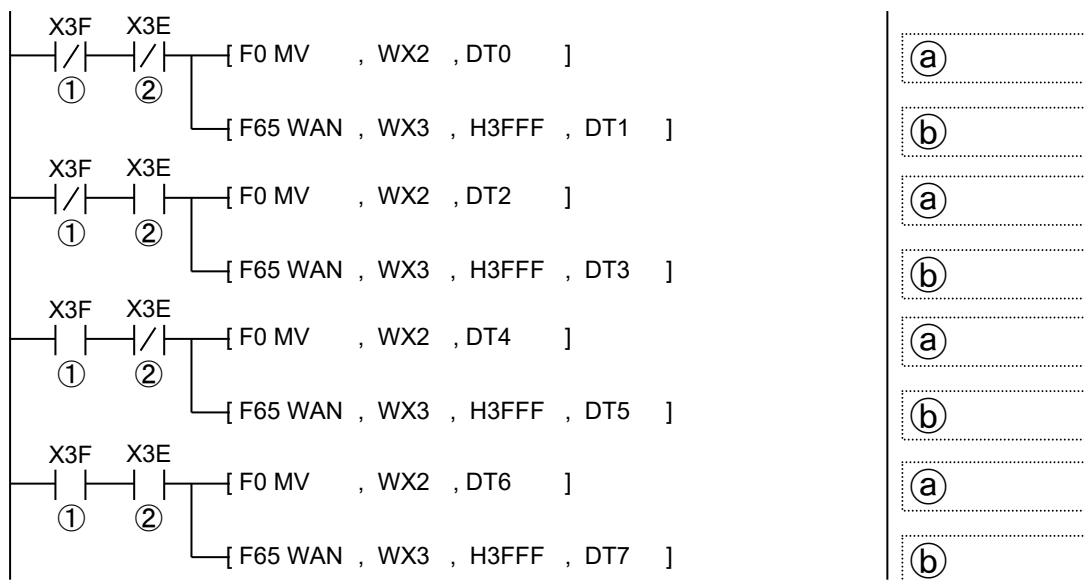

①	X3F	The channels of conversion data read by turning on/off the conversion data switching flags X3F and X3E are distinguished.
②	X3E	
Ⓐ	Conversion data of even numbered channels CH0/CH2/CH4/CH6 is transferred as is.	
Ⓑ	When the data of odd numbered channels CH1/CH3/CH5/CH7 is positive, the most significant two bits are masked by "00" with F65 WAN (AND) instruction, and the data is stored in DT1/DT3/DT5/DT7.	

4.2.2 Setting of Input Range and Averaging Processing (14-bit Mode Only)

When selecting the 14-bit mode in the analog input unit (FP0R-AD4/AD8), the input range and averaging method can be switched by user programs. They both can be set for each channel.

■ **Default settings**

The default settings are as follows; Input range for all channels: -10 to +10 V, Averaging processing: Moving average processing 10 times (Max. and min. removal). The averaging processing is enabled when the mode switch No. 5 is ON.

■ I/O allocation (External output WY)

Y	Y	Y	Y	Y	Y	Y	Y	Y	Y	Y	Y	Y	Y	Y	Y	Y	Y
3	3	3	3	3	3	3	3	3	3	3	3	3	3	3	3	3	3
F	E	D	C	B	A	9	8	7	6	5	4	3	2	1	0		

CH7	CH6	CH5	CH4	CH3	CH2	CH1	CH0
D	D	D	D	D	D	D	D
1	0	1	0	1	0	1	0

D1	D0	Averaging (Common to each channel)
0	0	Moving average 10 times (Max. and min. removal)
0	1	No. of averaging times: 64
1	0	No. of averaging times: 128
1	1	No averaging

Y	Y	Y	Y	Y	Y	Y	Y	Y	Y	Y	Y	Y	Y	Y	Y	Y	Y
2	2	2	2	2	2	2	2	2	2	2	2	2	2	2	2	2	2
F	E	D	C	B	A	9	8	7	6	5	4	3	2	1	0		

CH7	CH6	CH5	CH4	CH3	CH2	CH1	CH0
D	D	D	D	D	D	D	D
1	0	1	0	1	0	1	0

D1	D0	Range (Common to each channel)
0	0	-10V to +10V
0	1	-5V to +5V
1	0	0 to 10V
1	1	0 to 5V / 0 to 20mA

■ Sample program (Switching input range)

The following program shows the case that the input range of CH0 to CH7 of the first expansion analog input unit is set.

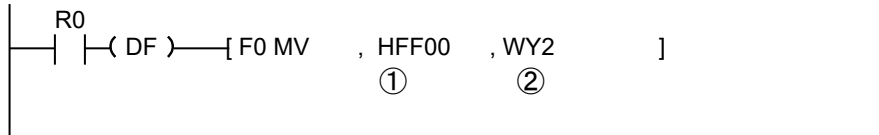

①		Input a constant for specifying an input range. Set it according to the I/O allocation on the previous page. In the above sample program, HFF00 is input for setting Y2F-Y28 to 1 and Y27-Y20 to 0. The range for CH4 to CH7 is 0 to 5 V/0 to 20 mA, and that for CH0 to CH3 is -10 V to +10 V.
②	WY2	Set it for switching the input range.

■ Sample program (Switching averaging processing method)

The following program shows the case that the averaging processing method of CH0 to CH7 of the first expansion analog input unit is set.

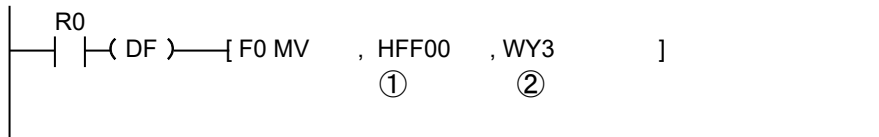

①		Input a constant for specifying an averaging method. Set it according to the I/O allocation on the previous page. In the above sample program, HFF00 is input for setting Y3F-Y38 to 1 and Y37-Y30 to 0. The method of CH4 to CH7 is no averaging processing, and that of CH0 to CH3 is moving average 10 times.
②	WY3	Set it for switching the averaging processing method.

4.3 Analog Output Unit (FP0R-DA4)

4.3.1 Writing of Digital Data for Output (12-bit Mode)

With the analog output unit, the conversion output is performed by using two bits as the switching flags of output channels and writing data.

■ **I/O allocation (12-bit FP0-A04 Compatibility mode)**

Two bits, the bits C and D, are used as the switching flags.

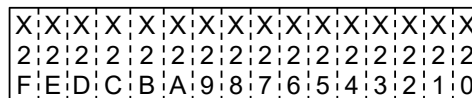
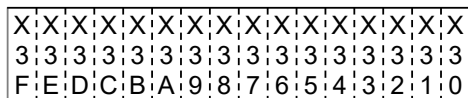

A1	A0	WY3
0	0	D/A conversion: None
0	1	CH1 data
1	0	CH3 data
1	1	D/A conversion: None

A1	A0	WY2
0	0	D/A conversion: None
0	1	CH0 data
1	0	CH2 data
1	1	D/A conversion: None

■ **Writing conversion data**

- The analog output unit writes the analog output digital data of a maximum of 4 channels to two memory areas (WY2/WY3) by user programs. Output data switching flags for specifying channels are allocated to the two bits of the memory area (WY2/WY3).
- In user programs, channels are specified by setting/resetting the output channel switching flag right after setting a digital value in the memory area.
- As CH0 and CH2, and CH1 and CH3 use each common memory area, data cannot be written to the unit in the same scan. Write data separated into two scans using scan pulse relay R9012, etc. In the channels which are not allocated to the same memory area, data can be written in the same scan.

Example	Processing	Description
When CH0 and CH1 are used	Writing CH0 data in WY2 at the time of "n" scan Writing CH1 data in WY3 at the time of "n" scan	Data can be written in WY2 and WY3 at the time of "n" scan.
When CH0 and CH2 are used	Writing CH0 data in WY2 at the time of "n" scan Writing CH2 data in WY2 at the time of "n+1" scan	Data can be written in WY2 once in 2 scanning processes (at the time of "n" and "n+1" scan).

■ When data is regarded as an error

- Digital data from the control unit is written in the analog output unit. When more than the specified amount of data (-2000 to 2000 for voltage type Unit, 0 to 4000 for current type Unit) is written in the Unit, the Unit regards the data as an error and writes the error flag in WX2. As a result, the D/A conversion is not performed. (For analog output, the previous data remains unchanged. When the correct data is written, the error flag is cleared and D/A conversion is executed.)
- Output data and output switching flag are allocated to the same I/O number. Data error can be detected successfully with the flags when the digital input value is within the range of K4096 to K4095. Even when the digital input value is out of the range, however, data conversion may be mistakenly conducted as shown below. To prevent this problem, be sure to set up the program to check the upper and lower limits of the digital value.

(Example): When writing K4096 in WY2

K4096= 0001 0000 0000 0000

Analog Output Unit regards Y2D and Y2C as output switching flags:

Y2D, Y2C = 01 <- CH0

Data =0000 0000 0000 <- 0

Consequently, the analog value that is equivalent to the digital value "0" is output from CH0.

■ Negative data

- When the negative data (minus data) is written, set the output switching flag to two's complement data. When specifying the minus data in the decimal data, the data automatically becomes two's complement data. Then, set the output switching flag to two's complement data in the same way as the plus data.

(Example): When writing -1 in CH0

-1=1111 1111 1111 1111 <- Two's complement

Setting the output switching flag: 1101 1111 1111 1111 (Bit C=1, Bit D=0 for CH0)

■ **Sample program (12-bit mode: For the range of -10 V to +10 V)**

The following program shows the case that the data of DT0 to DT3 is converted and output to the CH0 to CH3 of the first expansion analog output unit. The range for checking digital values written in the output area is changed.

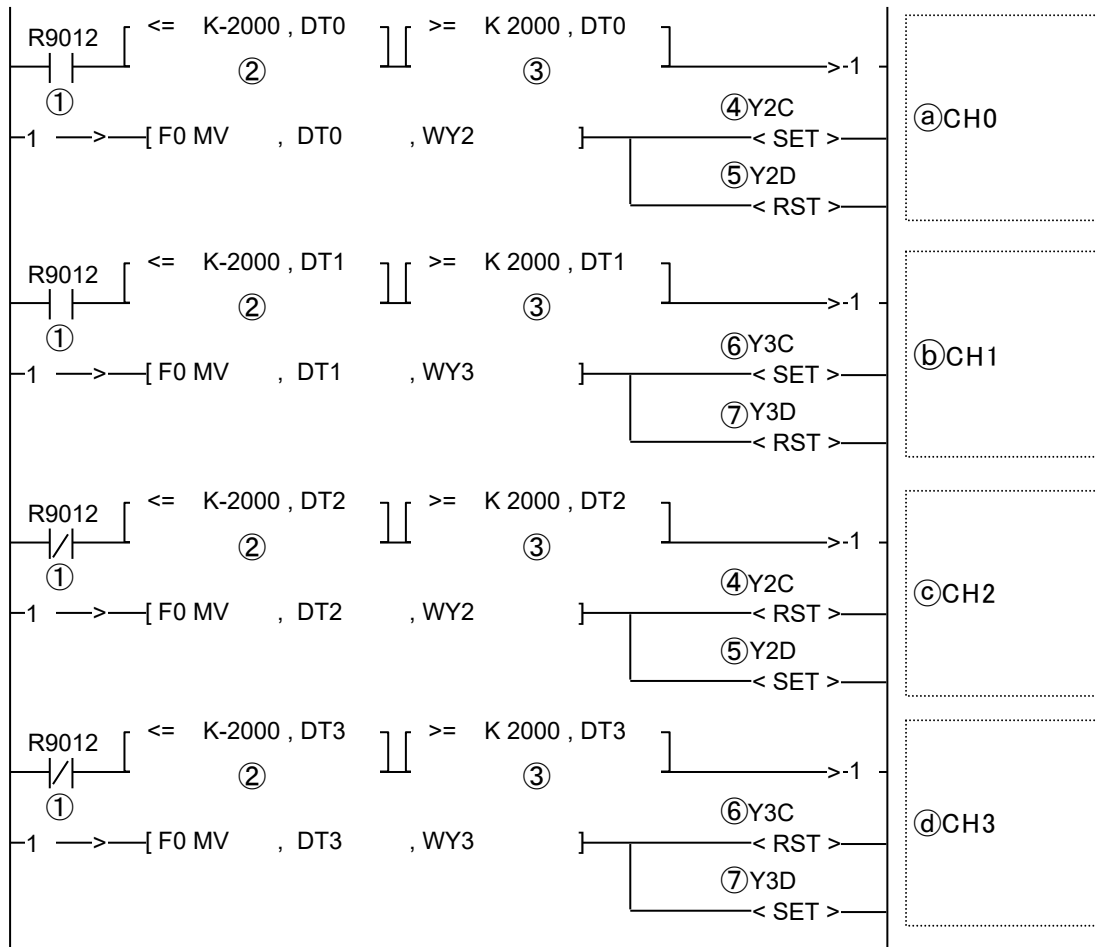

①	R9012	Switches the timing of writing data by the scan pulse realy.
②		Checks whether the lower limit value is within the data range that the unit can convert correctly.
③		Checks whether the upper limit value is within the data range that the unit can convert correctly.
④	Y2C	Output data switching flags for even numbered channels. Channel numbers are specified by the two-bit switching flags right after setting conversion data by the transfer instruction F0 MV.
⑤	Y2D	
⑥	Y3C	Output data switching flags for odd numbered channels. Channel numbers are specified by the two-bit switching flags right after setting conversion data by the transfer instruction F0 MV.
⑦	Y3D	
Ⓐ		It is executed when the scan pulse relay is ON and written data is within the upper and lower limits. Data for CH0 is set in DT0, and CH0 is specified by the output data switching flag.
Ⓑ		It is executed when the scan pulse relay is ON and written data is within the upper and lower limits. Data for CH1 is set in DT1, and CH1 is specified by the output data switching flag.
Ⓒ		It is executed when the scan pulse relay is OFF and written data is within the upper and lower limits. Data for CH2 is set in DT2, and CH2 is specified by the output data switching flag.
Ⓓ		It is executed when the scan pulse relay is OFF and written data is within the upper and lower limits. Data for CH3 is set in DT3, and CH3 is specified by the output data switching flag.



◆ KEY POINTS

- **In the FP0-A04-compatible 12-bit mode, Y2C, Y2D, Y3C and Y3D are used as the output data switching flags. Note that the allocation is different from that in the 14-bit mode.**

■ **Sample program (12-bit mode: For the range of 4 to 20 mA)**

The following program shows the case that the data of DT0 to DT3 is converted and output to the CH0 to CH3 of the first expansion analog output unit. The range for checking digital values written in the output area is changed.

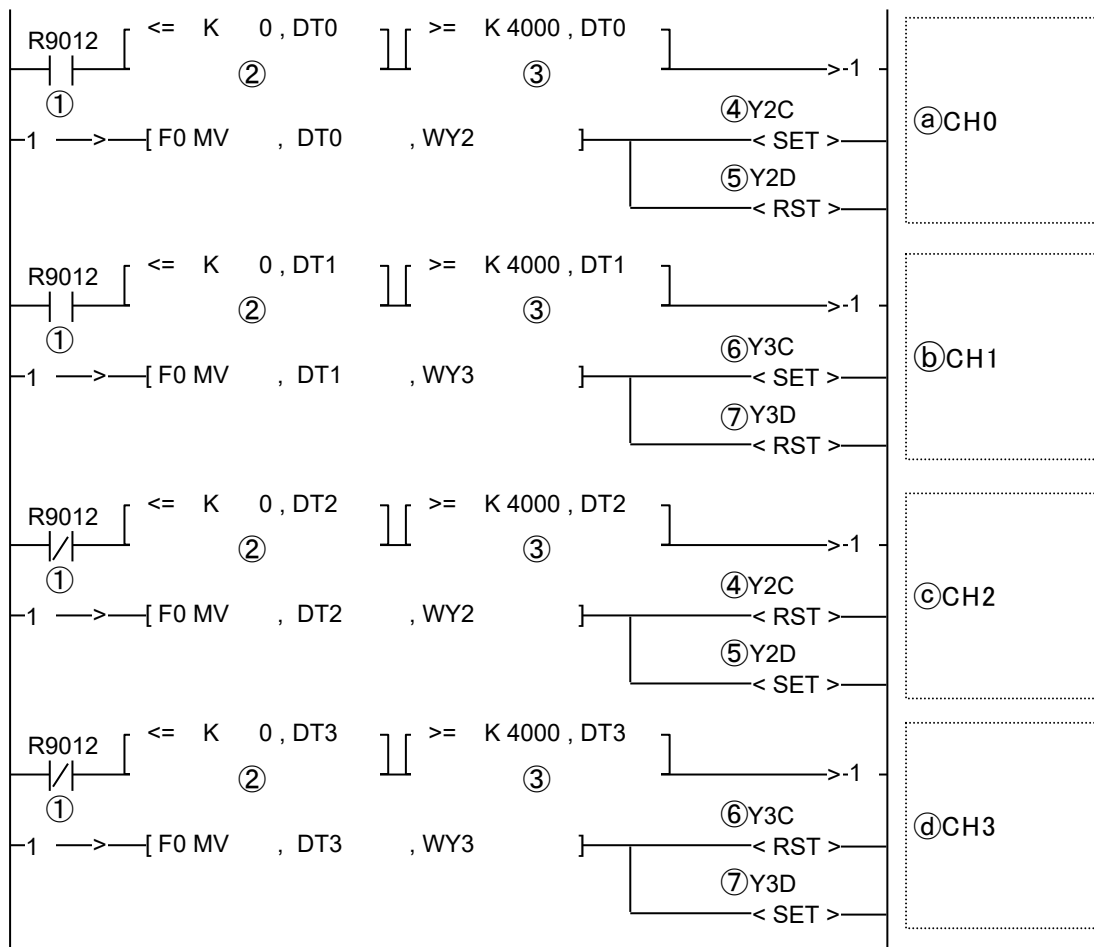

①	R9012	Switches the timing of writing data by the scan pulse realy.
②		Checks whether the lower limit value is within the data range that the unit can convert correctly.
③		Checks whether the upper limit value is within the data range that the unit can convert correctly.
④	Y2C	Output data switching flags for even numbered channels. Channel numbers are specified by the two-bit switching flags right after setting conversion data by the transfer instruction F0 MV.
⑤	Y2D	
⑥	Y3C	Output data switching flags for odd numbered channels. Channel numbers are specified by the two-bit switching flags right after setting conversion data by the transfer instruction F0 MV.
⑦	Y3D	
Ⓐ		It is executed when the scan pulse relay is ON and written data is within the upper and lower limits. Data for CH0 is set in DT0, and CH0 is specified by the output data switching flag.
Ⓑ		It is executed when the scan pulse relay is ON and written data is within the upper and lower limits. Data for CH1 is set in DT1, and CH1 is specified by the output data switching flag.
Ⓒ		It is executed when the scan pulse relay is OFF and written data is within the upper and lower limits. Data for CH2 is set in DT2, and CH2 is specified by the output data switching flag.
Ⓓ		It is executed when the scan pulse relay is OFF and written data is within the upper and lower limits. Data for CH3 is set in DT3, and CH3 is specified by the output data switching flag.



◆ KEY POINTS

- **In the FP0-A04-compatible 12-bit mode, Y2C, Y2D, Y3C and Y3D are used as the output data switching flags. Note that the allocation is different from that in the 14-bit mode.**

4.3.2 Writing of Digital Data for Output (14-bit Mode)

With the analog output unit, the conversion output is performed by using two bits as the switching flags of output channels and writing data.

■ **I/O allocation (14-bit mode)**

In the 14-bit mode, the most significant two bits are used as the switching flags. They are common to the flags for setting ranges.

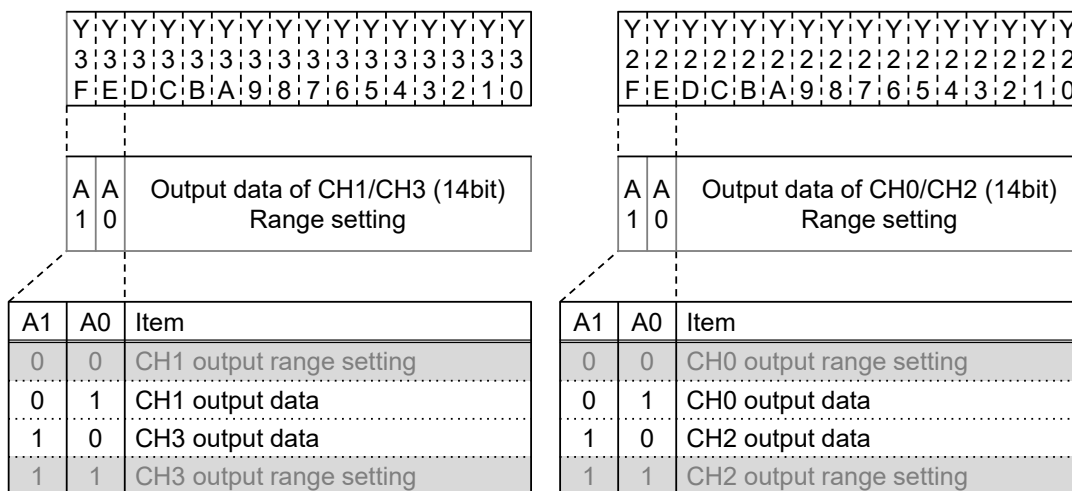

■ **Writing data for conversion**

- The analog output unit writes the analog output digital data of a maximum of 4 channels to two memory areas (WY2/WY3) by user programs. Output data switching flags for specifying channels are allocated to the two bits of the memory area (WY2/WY3).
- In user programs, channels are specified by setting/resetting the output channel switching flag right after setting a digital value in the memory area.
- As CH0 and CH2, and CH1 and CH3 use each common memory area, data cannot be written to the unit in the same scan. Write data separated into two scans using scan pulse relay R9012, etc. In the channels which are not allocated to the same memory area, data can be written in the same scan.

Example	Processing	Description
When CH0 and CH1 are used	Writing CH0 data in WY2 at the time of "n" scan Writing CH1 data in WY3 at the time of "n" scan	Data can be written in WY2 and WY3 at the time of "n" scan.
When CH0 and CH2 are used	Writing CH0 data in WY2 at the time of "n" scan Writing CH2 data in WY2 at the time of "n+1" scan	Data can be written in WY2 once in 2 scanning processes (at the time of "n" and "n+1" scan).

■ When data is regarded as an error

- Digital data from the control unit is written in the Analog Output Unit. When more than the specified amount of data (-8000 to 8000 for \pm range, 0 to 16000 for + range) is written in the Unit, the Unit regards the data as an error and writes the error flag in WX2. As a result, the D/A conversion is not performed. For analog output, the previous data remains unchanged. When the correct data is written, the error flag is cleared and D/A conversion is executed.
- Output data and output switching flag are allocated to the same I/O number. Data error can be detected successfully with the flags when the digital input value is within the range of -8192 to +8191 for \pm range, 0 to 16383 for + range. Even when the digital input value is out of the range, however, data conversion may be mistakenly conducted as shown below. To prevent this problem, be sure to set up the program to check the upper and lower limits of the digital value.

(Example): When writing K16384 in WY2

K16384= 0001 0000 0000 0000

Analog Output Unit regards Y2D and Y2C as output switching flags:

Y2F, Y2E = 01 <- CH0

Data =00 0000 0000 0000 <- 0

Consequently, the analog value that is equivalent to the digital value "0" is output from CH0.

■ Negative data

- When the negative data (minus data) is written, set the output switching flag to two's complement data. When specifying the minus data in the decimal data, the data automatically becomes two's complement data. Then, set the output switching flag to two's complement data in the same way as the plus data.

(Example): When writing -1 in CH0

-1=1111 1111 1111 1111 <- Two's complement

Setting the output switching flag: 0111 1111 1111 1111 (Bit F=1, Bit E=0 for CH0)

■ **Sample program (14-bit mode: For ranges of -10 V to +10 V and -5 V to +5 V)**

The following program shows the case that the data of DT0 to DT3 is converted and output to the CH0 to CH3 of the first expansion analog output unit. The range for checking digital values written in the output area is changed.

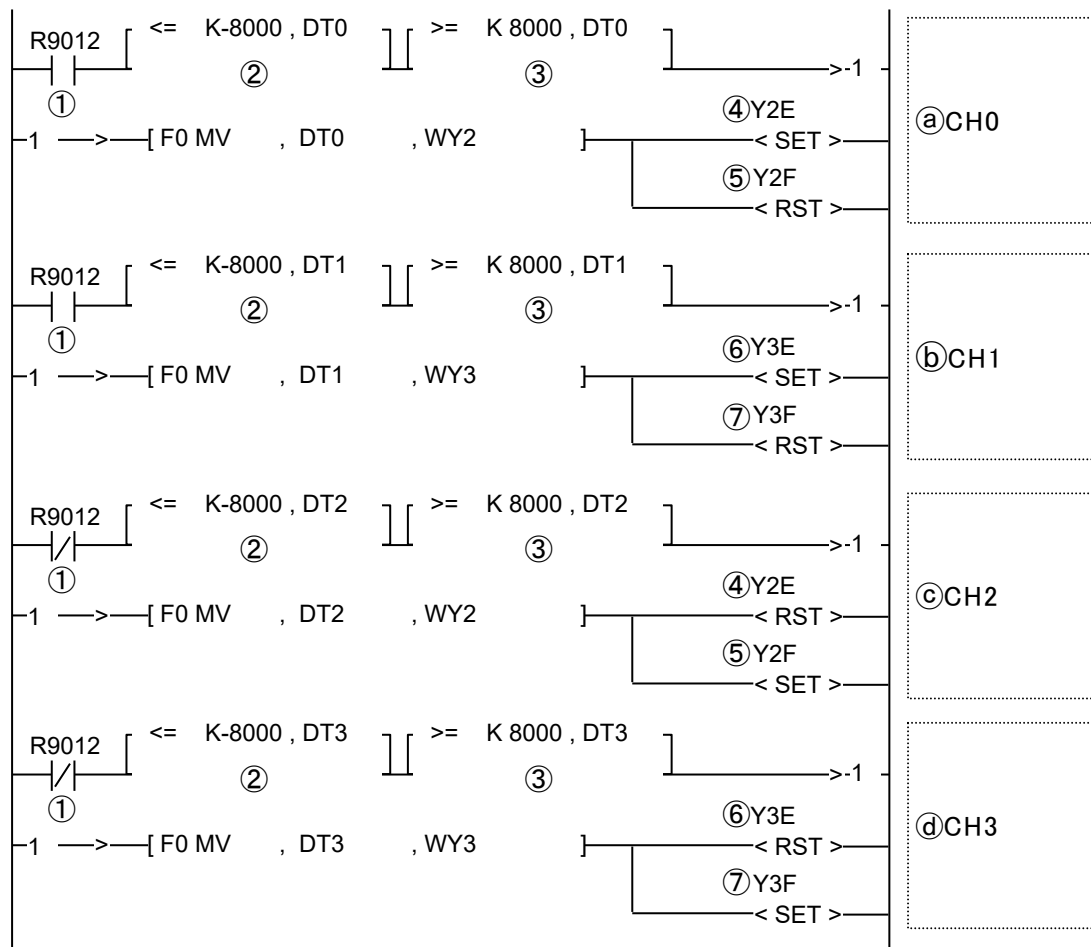

①	R9012	Switches the timing of writing data by the scan pulse realy.
②		Checks whether the lower limit value is within the data range that the unit can convert correctly.
③		Checks whether the upper limit value is within the data range that the unit can convert correctly.
④	Y2E	Output data switching flags for even numbered channels. Channel numbers are specified by the two-bit switching flags right after setting conversion data by the transfer instruction F0 MV.
⑤	Y2F	
⑥	Y3E	Output data switching flags for odd numbered channels. Channel numbers are specified by the two-bit switching flags right after setting conversion data by the transfer instruction F0 MV.
⑦	Y3F	
Ⓐ		It is executed when the scan pulse relay is ON and written data is within the upper and lower limits. Data for CH0 is set in DT0, and CH0 is specified by the output data switching flag.
Ⓑ		It is executed when the scan pulse relay is ON and written data is within the upper and lower limits. Data for CH1 is set in DT1, and CH1 is specified by the output data switching flag.
Ⓒ		It is executed when the scan pulse relay is OFF and written data is within the upper and lower limits. Data for CH2 is set in DT2, and CH2 is specified by the output data switching flag.
Ⓓ		It is executed when the scan pulse relay is OFF and written data is within the upper and lower limits. Data for CH3 is set in DT3, and CH3 is specified by the output data switching flag.



◆ KEY POINTS

- **In the 14-bit mode, Y2E, Y2F, Y3E, and Y3F are used as the output data switching flags. Note that the allocation is different from that in the FP0-A04-compatible 12-bit mode.**

■ **Sample program (14-bit mode: For ranges of 0 to 10 V, 0 to 5 V, 0 to 20 mA and 4 to 20 mA)**

The following program shows the case that the data of DT0 to DT3 is converted and output to the CH0 to CH3 of the first expansion analog output unit. The range for checking digital values written in the output area is changed.

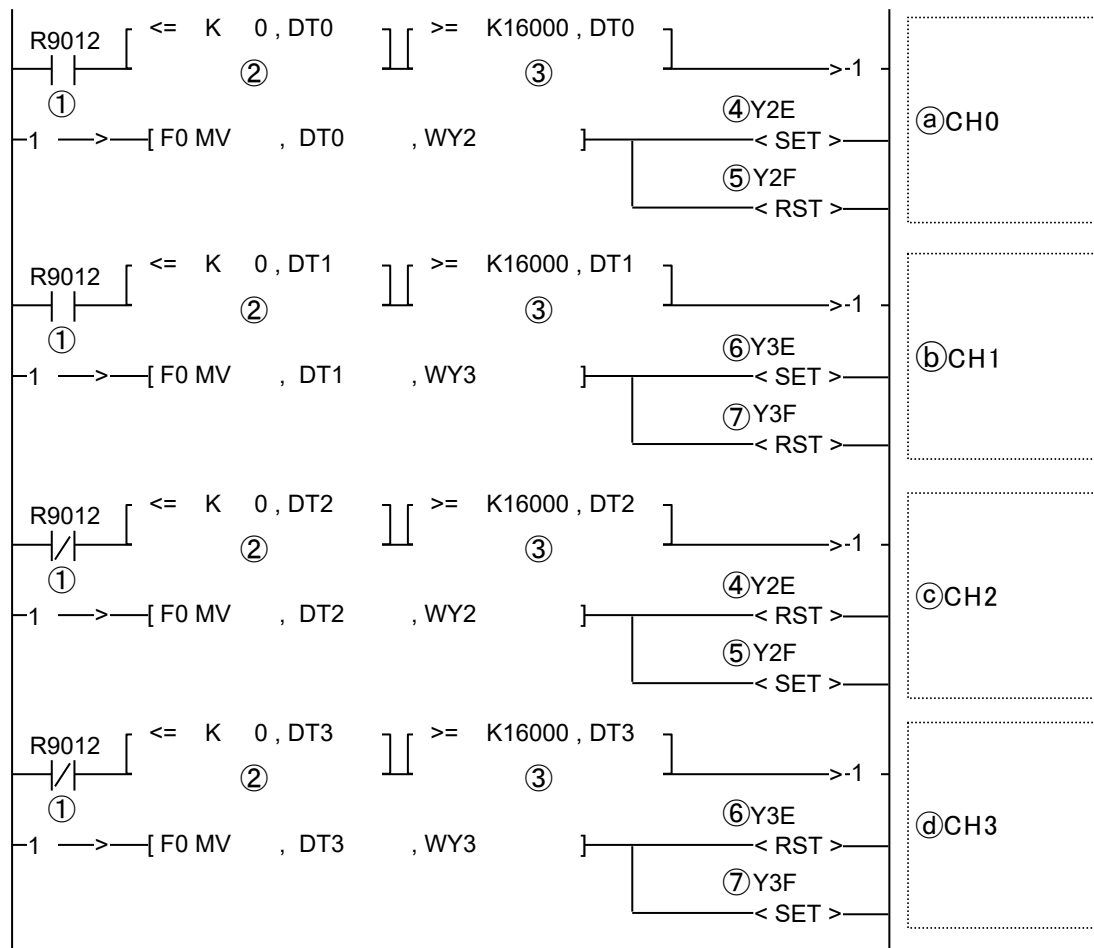

①	R9012	Switches the timing of writing data by the scan pulse realy.
②		Checks whether the lower limit value is within the data range that the unit can convert correctly.
③		Checks whether the upper limit value is within the data range that the unit can convert correctly.
④	Y2E	Output data switching flags for even numbered channels. Channel numbers are specified by the two-bit switching flags right after setting conversion data by the transfer instruction F0 MV.
⑤	Y2F	
⑥	Y3E	Output data switching flags for odd numbered channels. Channel numbers are specified by the two-bit switching flags right after setting conversion data by the transfer instruction F0 MV.
⑦	Y3F	
Ⓐ		It is executed when the scan pulse relay is ON and written data is within the upper and lower limits. Data for CH0 is set in DT0, and CH0 is specified by the output data switching flag.
Ⓑ		It is executed when the scan pulse relay is ON and written data is within the upper and lower limits. Data for CH1 is set in DT1, and CH1 is specified by the output data switching flag.
Ⓒ		It is executed when the scan pulse relay is OFF and written data is within the upper and lower limits. Data for CH2 is set in DT2, and CH2 is specified by the output data switching flag.
Ⓓ		It is executed when the scan pulse relay is OFF and written data is within the upper and lower limits. Data for CH3 is set in DT3, and CH3 is specified by the output data switching flag.



◆ KEY POINTS

- In the 14-bit mode, Y2E, Y2F, Y3E, and Y3F are used as the output data switching flags. Note that the allocation is different from that in the FP0-A04-compatible 12-bit mode.

4.3.3 Switching of Output Range (14-bit Mode Only)

When selecting the 14-bit mode in the analog output unit (FP0R-DA4), the output range can be switched by user programs. It can be set for each channel.

■ I/O allocation (External input WY)

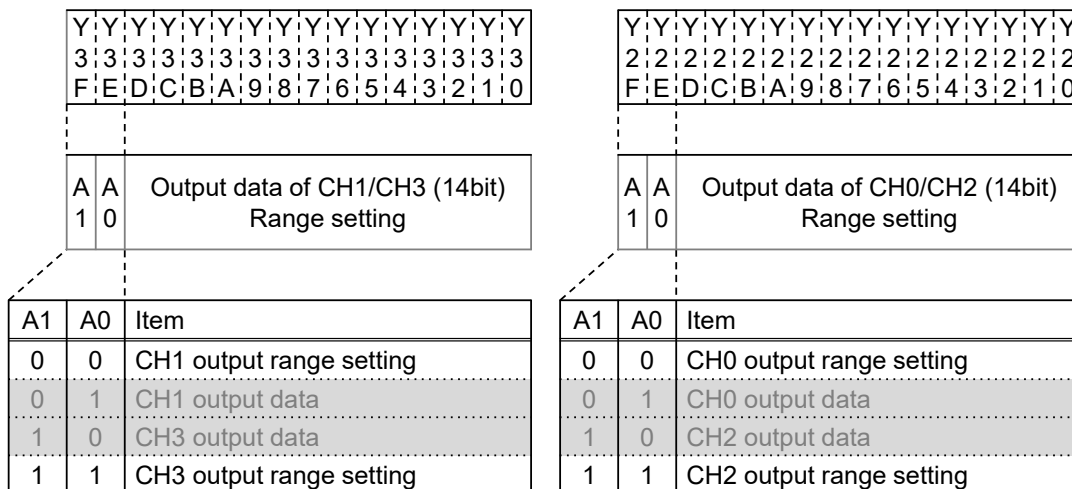

Each output range is specified by setting the following constants.

Item	Description
Output range setting	Input constants for specifying output ranges in the 14-bit area.
	H30 -10 to +10V / 0 to 20mA
	H31 -5 to +5V / 4 to 20mA
	H32 0 to 10V
	H33 0 to 5V

■ Default settings

The default settings are as follows; Output range for all channels: Voltage output range: -10 to +10 V, Current output range: 0 to 20 mA.

■ **Sample program (Switching output range: For CH0/CH1)**

The following program shows the case that the output ranges of CH0 and CH1 of the first expansion analog input unit is set.

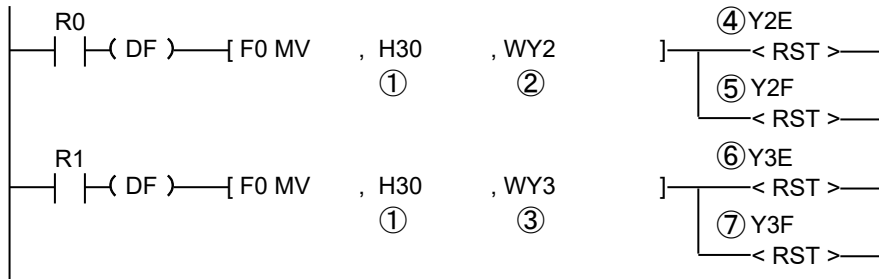

■ **Sample program (Switching output range: For CH2/CH3)**

The following program shows the case that the output ranges of CH2 and CH3 of the first expansion analog input unit is set.

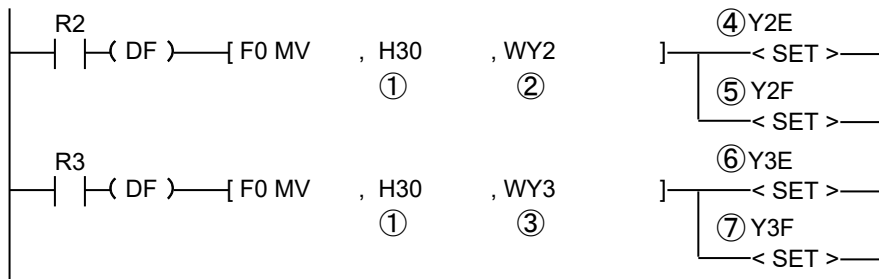

①	Input a constant for specifying an output range.	H30	-10 to +10V / 0~20mA
		H31	-5 to +5V / 4~20mA
		H32	0 to 10V
		H33	0 to 5V
②	WY2	Set it for switching the output range of CH0 or HC2.	
③	WY3	Set it for switching the output range of CH1 or HC3.	
④	Y2E	Output data switching flags for even numbered channels. When Y2E/Y2F is OFF, the output range of CH0 is set. When Y2E/Y2F is ON, the output range of CH2 is set.	
⑤	Y2F		
⑥	Y3E	Output data switching flags for odd numbered channels. When Y3E/Y3F is OFF, the output range of CH1 is set. When Y3E/Y3F is ON, the output range of CH3 is set.	
⑦	Y3F		



◆ **KEY POINTS**

- For CH0/CH1, the output switching flags are reset. For CH2/CH3, the output switching flags are set.
- The output switching flags (bit F/bit E) are also used for setting output data. Create a program not to overwrite each other during an operation processing.

4.3.4 Status Information (12-bit mode)

With the analog output unit, the following information can be monitored in the external input area WX.

■ **Status information**

I/O No.	Description	
X20	Analog output unit power	0: OFF, 1:ON、
X21-X23	Used in the system	
X24	CH0 data writing status	0:Normal, 1>Error (Note 1) An error occurs when data written to the memory area (WY2/WY3) is out of each range, and the data conversion is not performed. The error is cleared when data within the range is written and the conversion is performed.
X25	CH1 data writing status	
X26	CH2 data writing status	
X27	CH3 data writing status	
X28-X2F	Used in the system	

(Note 1): Output data and output CH switch flag are allocated to the same I/O number. Data error can be detected successfully with the flags when the digital input value is within the range of K-4096 to K4095. Even when the digital input value is out of the range, however, data conversion may be mistakenly conducted. To prevent this problem, be sure to set up the program to check the upper and lower limits of the digital value.

4.3.5 Status information (14-bit mode)

With the analog output unit, the following information can be monitored in the external input area WX.

■ Status information

I/O No.	Description	
X20	Analog output unit power	0:OFF, 1:ON、
X21-X23	Used in the system	
X24	CH0 data writing status	0:Normal, 1:Error (Note 1)
X25	CH1 data writing status	An error occurs when data written to the memory area (WY2/WY3) is out of each range, and the data conversion is not performed. The error is cleared when data within the range is written and the conversion is performed.
X26	CH2 data writing status	
X27	CH3 data writing status	
X28-X2F	Used in the system	
X30-X33	CH0 range setting state	The state of a specified output range can be monitored. The following constants are stored for each range. H0: -10V to +10V, 0mA to 20mA H1: -5V to +5V, 4mA to 20mA H2: 0V to 10V H3: 0V to 5V
X34-X37	CH1 range setting state	Same as above.
X38-X3B	CH2 range setting state	Same as above.
X3C-X3F	CH3 range setting state	Same as above.

(Note 1):As output data and the output switching flag are allocated to the same I/O, a data error is detected correctly only when a digital input value is within (K-8192 to K8191) for the \pm range and (K0 to K16383) for the + range. In the case of digital input values exceeding these ranges, data may be converted without an error, so always insert a program which checks the upper and lower limits.

(Note 2):In the 14-bit mode, the range setting state of each channel specified in WY2 and WY3 can be confirmed.

4.4 Analog I/O Unit (FP0R-A21/A42)

4.4.1 Reading of Analog Input Values (For A21)

With the analog input unit A21, data can be read as signed 16-bit data as is.

■ I/O allocation (External input WX)

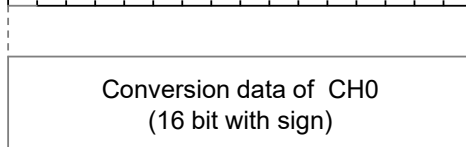
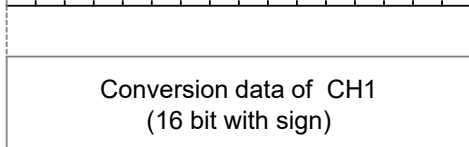
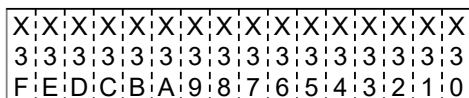

WX3	WX2
CH1data	CH0 data

■ Sample program (For FP0R-A21)

The following program shows the case that conversion data of the first expansion analog input unit (FP0R-A21) (CH0 to CH7) is read and stored in DT0 to DT7.

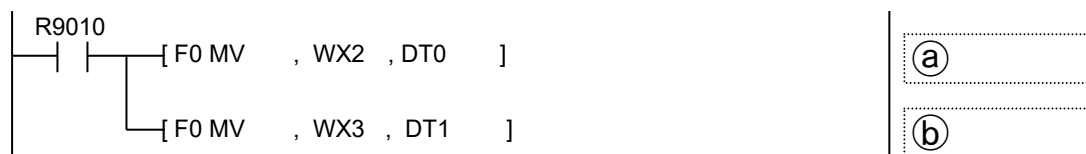

a	The conversion data of CH0 is stored into DT0.
b	The conversion data of CH1 is stored into DT1.

4.4.2 Reading of Analog Input Values (For A42)

The analog input unit uses the most significant 2 bits as a flag for switching channels and reads conversion data sequentially.

■ I/O allocation (External input WX)

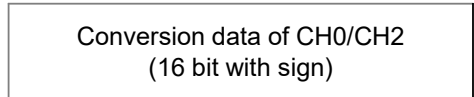
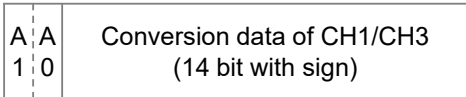
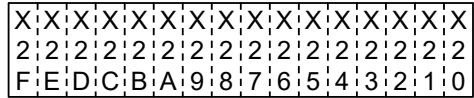
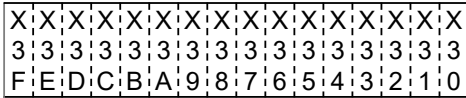

Conversion data switch flag

A1	A0	WX3	WX2
0	0	CH1 data	CH0 data
0	1	CH3 data	CH2 data

■ Role of conversion data switching flag

- The analog I/O unit (FP0R-A42) reads the analog input data of a maximum of 4 channels using two memory areas (WX2 and WX3). The most significant two bits are allocated as a conversion data switching flag for distinguishing channels.
- Conversion data of even numbered channels can be read as 16-bit data as they are.
- As conversion data of odd numbered channels contain the conversion data switching flag of most significant two bits, mask processing needs to be applied to the data with a user program. Plus conversion data should be masked by "00", and minus conversion data should be masked by "11". Create a program in reference to the following programs.

(Example): For reading data of CH3

CH3 data	WX3	Data after masking	Description
1	0100 0000 0000 0001	0000 0000 0000 0001	Most significant two bits are masked by "00".
-1	0111 1111 1111 1111	1111 1111 1111 1111	Most significant two bits are masked by "11".

■ **Sample program (FP0R-A42: For ranges of -10 V to +10 V and -5 V to +5 V)**

The following program shows the case that conversion data of the first expansion analog I/O unit (FP0R-A42) (CH0 to CH3) is read and stored in DT0 to DT3.

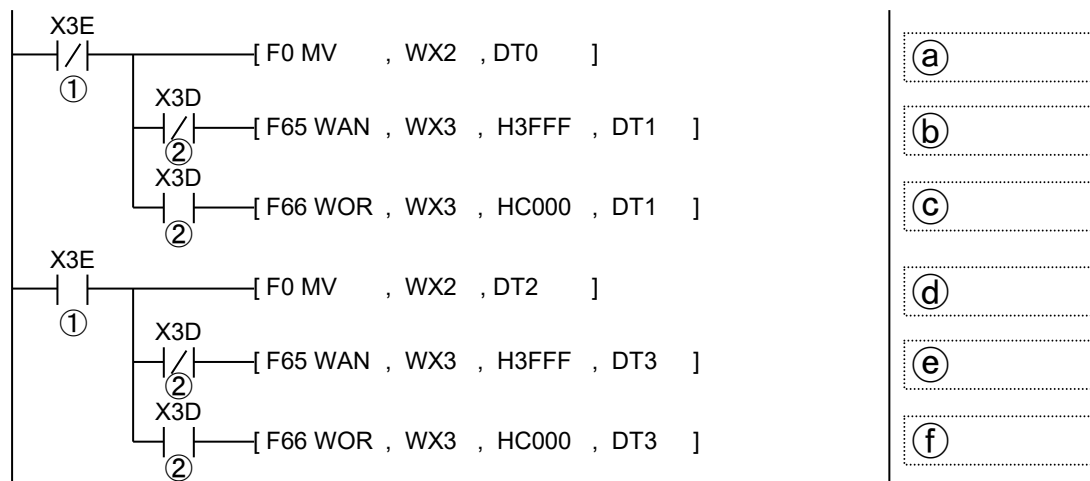

①	X3E	The channels of conversion data read by turning on/off the conversion data switching flag X3E are distinguished.
②	X3D	The signs of read conversion data of CH1/CH3 are distinguished. When plus, OFF. When minus, ON.
(a)	The conversion data of CH0 is transferred to DT0.	
(b)	When the data of CH1 is positive, the most significant two bits are masked by "00" with F65 WAN (AND) instruction, and the data is stored in DT1.	
(c)	When the data of CH1 is negative, the most significant two bits are masked by "11" with F66 WOR (OR) instruction, and the data is stored in DT1.	
(d)	The conversion data of CH2 is transferred to DT2.	
(e)	When the data of CH3 is positive, the most significant two bits are masked by "00" with F65 WAN (AND) instruction, and the data is stored in DT3.	
(f)	When the data of CH3 is negative, the most significant two bits are masked by "11" with F66 WOR (OR) instruction, and the data is stored in DT3.	

■ Sample program (FP0R-A42: (For ranges of 0 to 10 V, 0 to 5 V and 0 to 20 mA)

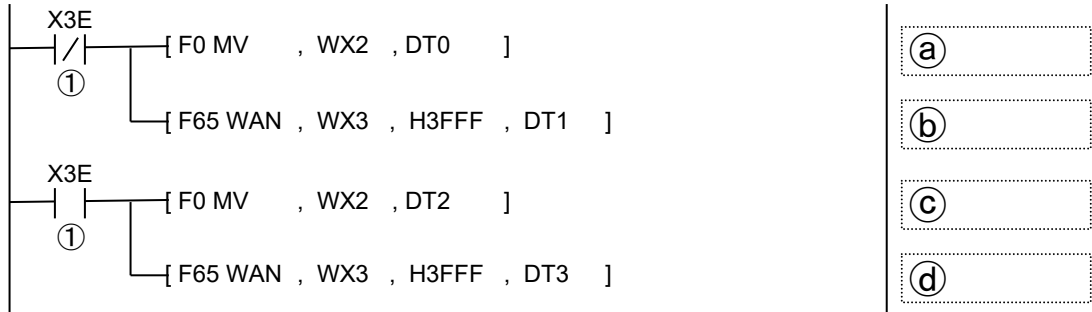

①	X3E	The channels of conversion data read by turning on/off the conversion data switching flags X3F and X3E are distinguished.
Ⓐ		The conversion data of CH0 is stored into DT0.
Ⓑ		The most significant two bits are masked by "00" with F65 WAN (AND) instruction, and the data is stored in DT1. (Note)
Ⓒ		The conversion data of CH2 is stored into DT2.
Ⓓ		The most significant two bits are masked by "00" with F65 WAN (AND) instruction, and the data is stored in DT3.

(Note):In the case of data of CH1, it can be replaced with the transfer instruction F0 MV as the conversion data switching flag is "00".

4.4.3 Writing of Digital Data for Output (12-bit Mode)

The analog I/O unit (FP0R-A42/A21) writes data for conversion as the output switching flags are not contained in the 12-bit mode.

■ I/O allocation (12-bit mode)

WY3	WY2
CH1 data	CH0 data

■ Writing data for conversion

- The analog I/O unit writes the analog output digital data of a maximum of 2 channels to two memory areas (WY2/WY3) by user programs.



◆ NOTE

- Always insert a program which checks the upper and lower limits to make written digital values be within the allowable data ranges referring the programs described on the following pages.

Mode	Range setting	Lower limit	Upper limit
12-bit mode	± range	-2000	2000
	+ range	0	4000

■ Sample program (12-bit mode: -10V to +10V range)

The following program shows the case that the data of DT0 to DT1 is converted and output to the CH0 to CH1 of the first expansion analog I/O unit (FP0R-A42/A21).

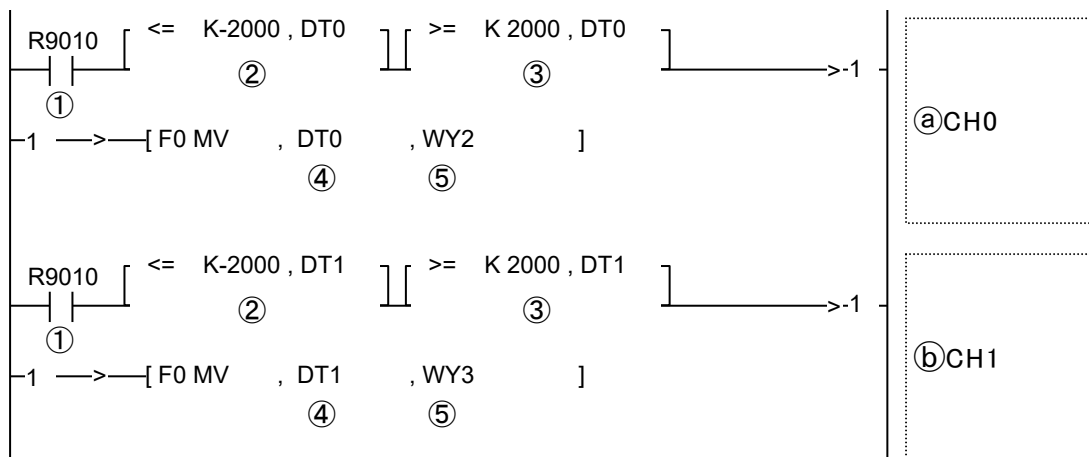

■ Sample program (12-bit mode: 0 to 20mA range)

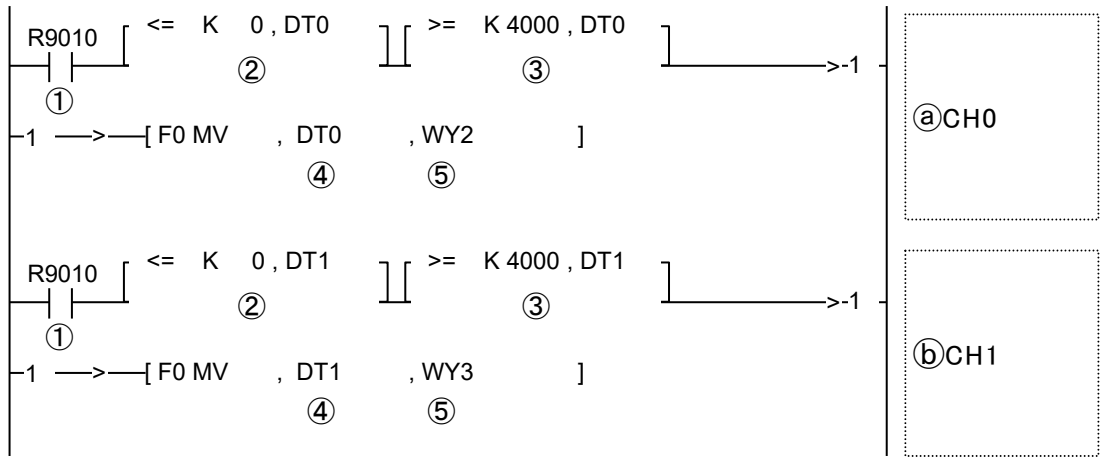

①	R9010	Always ON relay
②	Checks whether the lower limit value is within the data range that the unit can convert correctly.	
③	Checks whether the upper limit value is within the data range that the unit can convert correctly.	
a)	It is executed when the execution condition is ON and written data is within the upper and lower limits. Data for CH0 is set in DT0, and CH0 is specified by the output data switching flag.	
b)	It is executed when the execution condition is ON and written data is within the upper and lower limits. Data for CH1 is set in DT1, and CH1 is specified by the output data switching flag.	

4.4.4 Writing of Digital Data for Output (14-bit Mode)

With the analog I/O unit (FP0R-A42/A21), the conversion output is performed by using two bits as the switching flags of output channels and writing data.

■ **I/O allocation (14-bit mode)**

In the 14-bit mode, the most significant two bits are used as the switching flags. They are common to the flags for setting ranges.

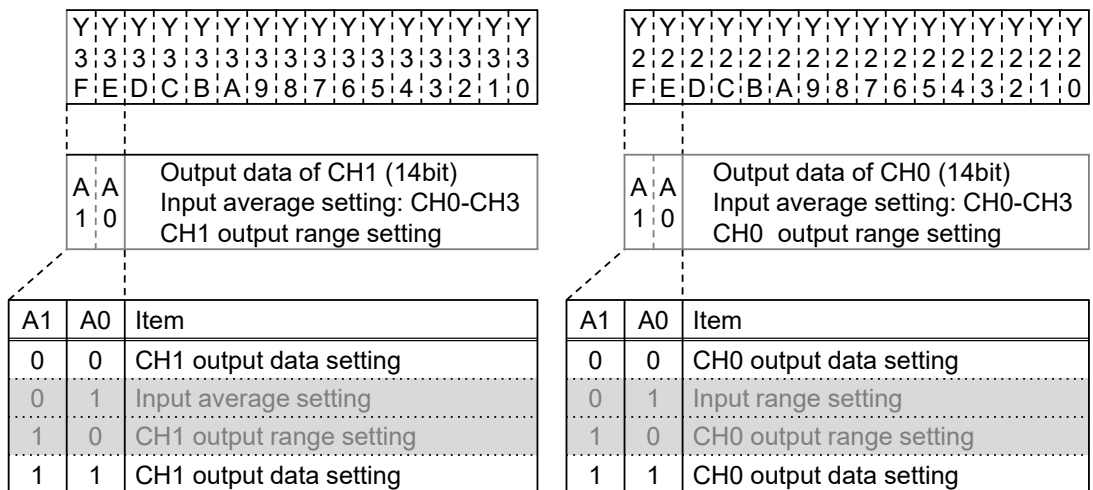

■ **Writing data for conversion**

- The analog I/O unit writes the analog output digital data of a maximum of 2 channels to two memory areas (WY2/WY3) by user programs.



◆ **NOTE**

- **Protect output switching flags from being overwritten by a subsequent program after writing data. Output data becomes invalid.**
- **Always insert a program which checks the upper and lower limits to make written digital values be within the allowable data ranges referring the programs described on the following pages.**

Mode	Range setting	Lower limit	Upper limit
14-bit mode	±range	-8000	8000
	+range	0	16000

- **For the analog I/O unit (FP0R-A21/A42), the data setting becomes valid when the output switching flags (Y2F, Y2E) or (Y3F, Y3E) are (0, 0) or (1, 1). When written digital values are within the range in the above table, it is not necessary to add programs for setting or setting the output switching flags after data transmission like the following programs because the output switching flags (Y2F, Y2E) or (Y3F, Y3E) are always (0, 0) or (1, 1).**

■ **Sample program (14-bit mode: For ranges of -10 V to +10 V and -5 V to +5 V)**

The following program shows the case that the data of DT0 to DT1 is converted and output to the CH0 to CH1 of the first expansion analog I/O unit (FP0R-A42/A21). The range for checking digital values written in the output area is changed.

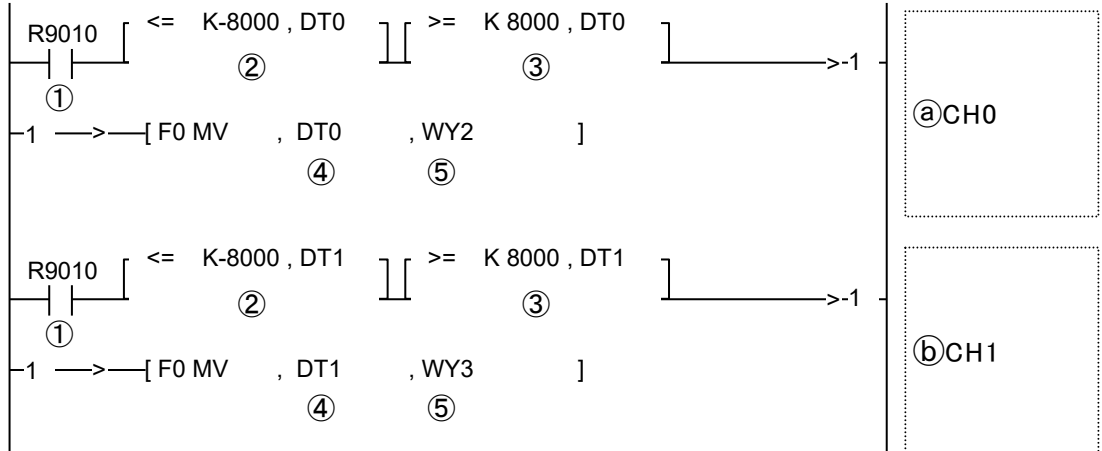

■ **Sample program (14-bit mode: (For ranges of 0 to 10 V, 0 to 5 V, 0 to 20 mA and 4 to 20 mA)**

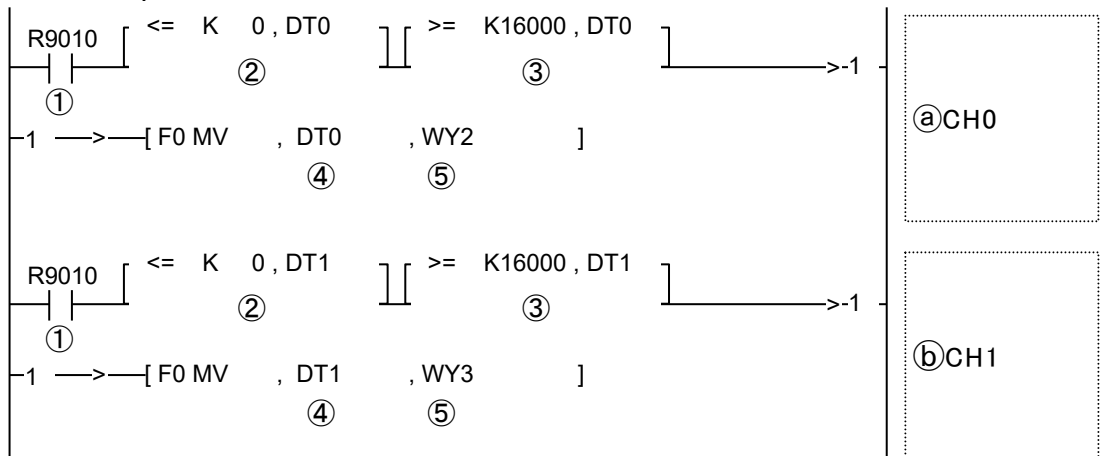

①	R9010	Always ON relay
②	Checks whether the lower limit value is within the data range that the unit can convert correctly.	
③	Checks whether the upper limit value is within the data range that the unit can convert correctly.	
a)	It is executed when the execution condition is ON and written data is within the upper and lower limits. Data for CH0 is set in DT0, and CH0 is specified by the output data switching flag.	
b)	It is executed when the execution condition is ON and written data is within the upper and lower limits. Data for CH1 is set in DT1, and CH1 is specified by the output data switching flag.	

4.4.5 Switching of Input Range and Averaging Method (14-bit Mode Only)

When selecting the 14-bit mode in the analog I/O unit (FP0R-A21/A42), the input range or averaging method for each channel can be set by user programs.

■ I/O allocation (External output WY)

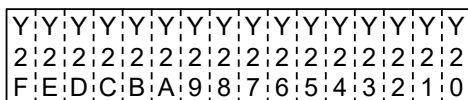
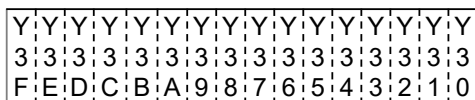

A1	A0	Item
0	0	CH1 output data setting
0	1	Input average setting
1	0	CH1 output range setting
1	1	CH1 output data setting

A1	A0	Item
0	0	CH0 output data setting
0	1	Input range setting
1	0	CH0 output range setting
1	1	CH0 output data setting

Set the contents allocated to CH0 to CH3 for the input averaging processing and input range by replacing the following 8-bit data with Hex data.

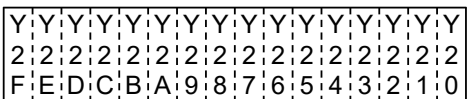
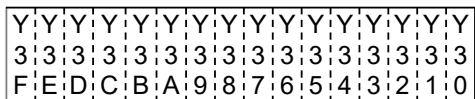

A1	A0	Specify 0	CH3	CH2	CH1	CH0
1	0		D	D	D	D
1	0		1	0	1	0

A1	A0	Specify 0	CH3	CH2	CH1	CH0
1	0		D	D	D	D
1	0		1	0	1	0

D1	D0	Averaging (Common to each channel)
0	0	Moving average 10 times (Max. and min. removal)
0	1	No. of averaging times: 64
1	0	No. of averaging times: 128
1	1	No averaging

D1	D0	Range (Common to each channel)
0	0	-10V to +10V
0	1	-5V to +5V
1	0	0 to 10V
1	1	0 to 5V / 0 to 20mA

■ Default settings

The default settings are as follows; Input range for all channels: -10 to +10 V, Averaging processing: Moving average processing 10 times (Max. and min. removal). The averaging processing is enabled when the mode switch No. 5 is ON.

■ Sample program (Input range switching)

The following program shows the case that the input range of CH0 to CH3 of the first expansion analog I/O unit (FP0R-A42/A21) is set.

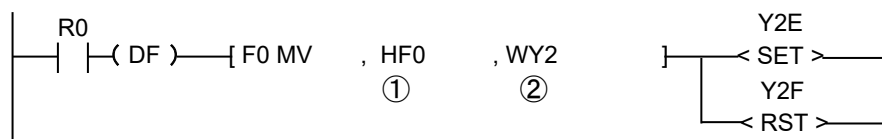

①		Input a constant for specifying an input range. Set it according to the I/O allocation on the previous page. In the above sample program, HF0 is input for setting Y27-Y24 to 1 and Y23-Y20 to 0. The range for CH3/CH2 is 0 to 5 V/0 to 20 mA, and that for CH1/CH0 is -10 V to +10 V.
②	WY2	Set it for switching the input range.
③	Y2E	Data switching flags. When Y2E is ON and Y2F is OFF, the input range is set.
④	Y2F	

■ Sample program (Input averaging switching)

The following program shows the case that the averaging processing method of CH0 to CH3 of the first expansion analog I/O unit (FP0R-A42/A21) is set.

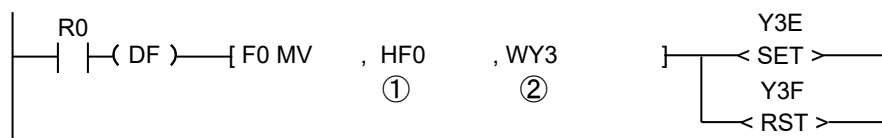

①		Input a constant for specifying an averaging method. Set it according to the I/O allocation on the previous page. In the above sample program, HF0 is input for setting Y37-Y34 to 1 and Y33-Y30 to 0. The method of CH3/CH2 is no averaging processing, and that of CH1/CH0 is moving average 10 times.
②	WY3	Set it for switching the averaging processing method.
③	Y3E	Data switching flags. When Y3E is ON and Y3F is OFF, the averaging method of input is set.
④	Y3F	



◆ KEY POINTS

- The input range setting and the input averaging method for four channels are set collectively.

4.4.6 Switching of Output Range (14-bit Mode Only)

When selecting the 14-bit mode in the analog I/O unit (FP0R-A21/A42), the output range can be switched by user programs. It can be set for each channel.

■ I/O allocation (External output WY)

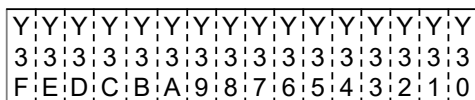

A:A
1:0
Output data of CH1 (14bit)
Input average setting: CH0-CH3
CH1 output range setting

A1	A0	Item
0	0	CH1 output data setting
0	1	Input a average setting
1	0	CH1 output range setting
1	1	CH1 output data setting



A:A
1:0
Output data of CH0 (14bit)
Input average setting: CH0-CH3
CH0 output range setting

A1	A0	Item
0	0	CH0 output data setting
0	1	Input range setting
1	0	CH0 output range setting
1	1	CH0 output data setting

Each output range is specified by setting the following constants.

Item	Description
Output range setting	Input constants for specifying output ranges in the 14-bit area.
	H30 -10 to +10V / 0 to 20mA
	H31 -5 to +5V / 4 to 20mA
	H32 0 to 10V
	H33 0 to 5V

■ Default settings

The default settings are as follows; Output range for all channels: Voltage output range: -10 to +10 V, Current output range: 0 to 20 mA.



◆ KEY POINTS

- The output ranges are set for two channels separately.

■ Sample program (Output range switching)

The following program shows the case that the input range of CH0 and CH1 of the first expansion analog I/O unit (FP0R-A21/A42) is set.

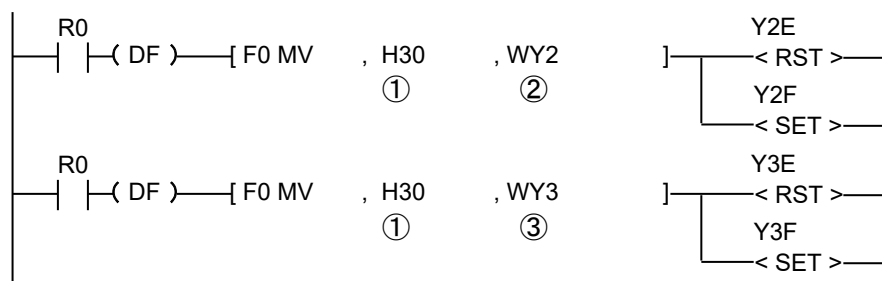

①	Input a constant for specifying an output range.	H30	-10 to +10V / 0 to 20mA
		H31	-5 to +5V / 4 to 20mA
		H32	0 to 10V
		H33	0 to 5V
②	WY2	Set it for switching the output range of CH0.	
③	WY3	Set it for switching the output range of CH1.	
④	Y2E	Output data switching flag for CH0. When Y2E is OFF and Y2F is ON, the output range of CH0 is set.	
⑤	Y2F		
⑤	Y3E	Output data switching flag for CH1. When Y3E is OFF and Y3F is ON, the output range of CH1 is set.	
⑦	Y3F		

4.5 I/O Conversion Characteristics

4.5.1 Input Conversion Characteristics (Voltage Range)

■ **-10V to +10V DC input**

Conversion characteristic	Correspondence table of A/D Conversion values		
	Input voltage (V)	Digital value	
		12-bit	14-bit
	-10.0	-2000	-8000
	-5.0	-1000	-4000
	0	0	0
	5.0	1000	4000
	10.0	2000	8000
	If the input value is out of the range		
	Input voltage (V)	Digital value	
		12-bit	14-bit
-10V or less	-2000	-8000	
10V or more	2000	8000	

(Note 1): In the analog input unit Ver.1.1 or earlier or the analog I/O unit, a digital conversion value equivalent to the analog input of approx. 2 V is saved in the device (WX), for the channels to which no input is connected. The analog input unit Ver.1.2 or later are equivalent to approx. 0V.

■ **-5V to +5V DC input (14-bit mode only)**

Conversion characteristic	Correspondence table of A/D Conversion values	
	Input voltage (V)	Digital value
		14-bit
	-5.0	-8000
	-2.5	-4000
	0	0
	2.5	4000
	5.0	8000
	If the input value is out of the range	
	Input voltage (V)	Digital value
		14-bit
-5V or less	-8000	
5V or more	8000	

(Note 1): In the analog input unit Ver.1.1 or earlier or the analog I/O unit, a digital conversion value equivalent to the analog input of approx. 2 V is saved in the device (WX), for the channels to which no input is connected. The analog input unit Ver.1.2 or later are equivalent to approx. 0V.

■ 0V to 10V DC input (14-bit mode only)

Conversion characteristic	Correspondence table of A/D Conversion values	
	Input voltage (V)	Digital value 14-bit
	0.0	0
	2.5	4000
	5.0	8000
	7.5	12000
	10.0	16000
	Processing if the range is exceeded	
	Input voltage (V)	Digital value 14-bit
	0V or less (including negative value)	0
	10V or more	16000

(Note 1): In the analog input unit Ver.1.1 or earlier or the analog I/O unit, a digital conversion value equivalent to the analog input of approx. 2 V is saved in the device (WX), for the channels to which no input is connected. The analog input unit Ver.1.2 or later are equivalent to approx. 0V.

■ 0V to 5V DC input

Conversion characteristic	Correspondence table of A/D Conversion values		
	Input voltage (V)	Digital value	
		12-bit	14-bit
	0.0	0	0
	1.25	1000	4000
	2.5	2000	8000
	3.75	3000	12000
	5.0	4000	16000
	Processing if the range is exceeded		
	Input voltage (V)	Digital value	
		12-bit	14-bit
0V or less (including negative value)	0	0	
5V or more	4000	16000	

(Note 1): In the analog input unit Ver.1.1 or earlier or the analog I/O unit, a digital conversion value equivalent to the analog input of approx. 2 V is saved in the device (WX), for the channels to which no input is connected. The analog input unit Ver.1.2 or later are equivalent to approx. 0V.

■ -100mV to +100mV DC input (12-bit mode only)

Conversion characteristic	Correspondence table of A/D Conversion values	
	Input voltage (mV)	Digital value
		12-bit
	-100.0	-2000
	-75.0	-1500
	-50.0	-1000
	-25.0	-500
	0.0	0
	+25.0	+500
	+50.0	+1000
	+75.0	+1500
	+100.0	+2000
	Processing if the range is exceeded	
	Input voltage (V)	Digital value
		12-bit
-100mV or less	-2000	
+100mV or more	+2000	

(Note 1): Installed in the unit of Ver.1.2 and after (only 12-bit mode).

4.5.2 Input conversion Characteristics (Current Range)

■ 0mA to 20mA DC input

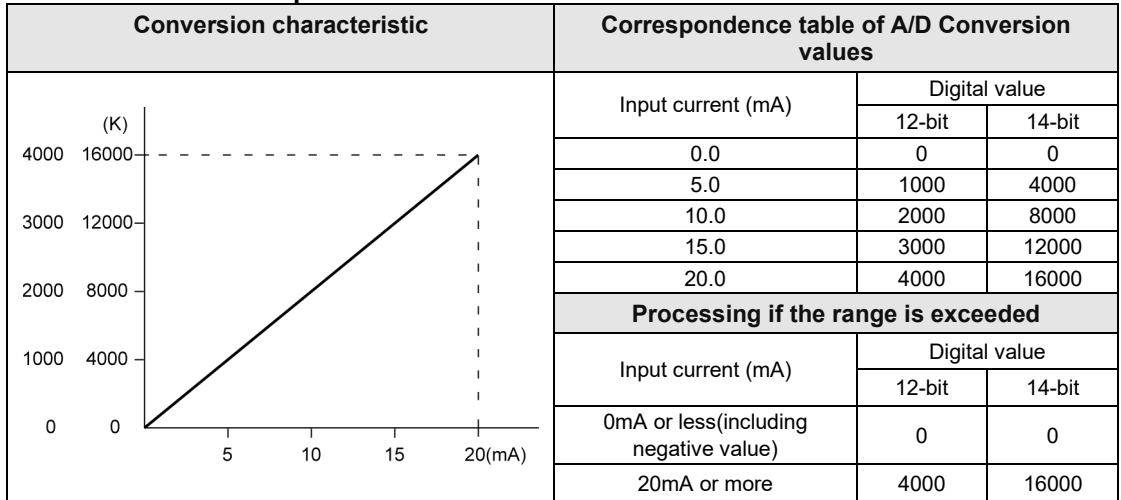

4.5.3 Output conversion Characteristics (Voltage Range)

■ -10V to 10V DC output

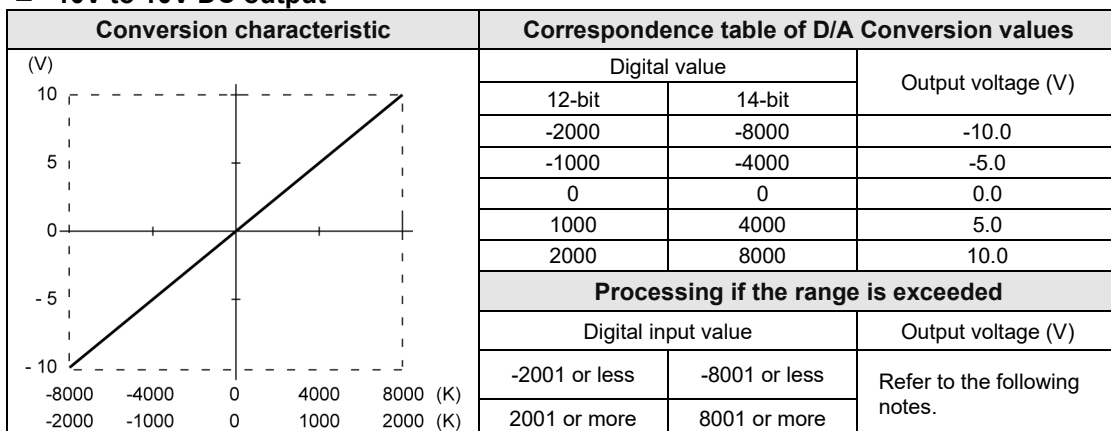

■ -5V to 5V DC output (14-bit mode only)

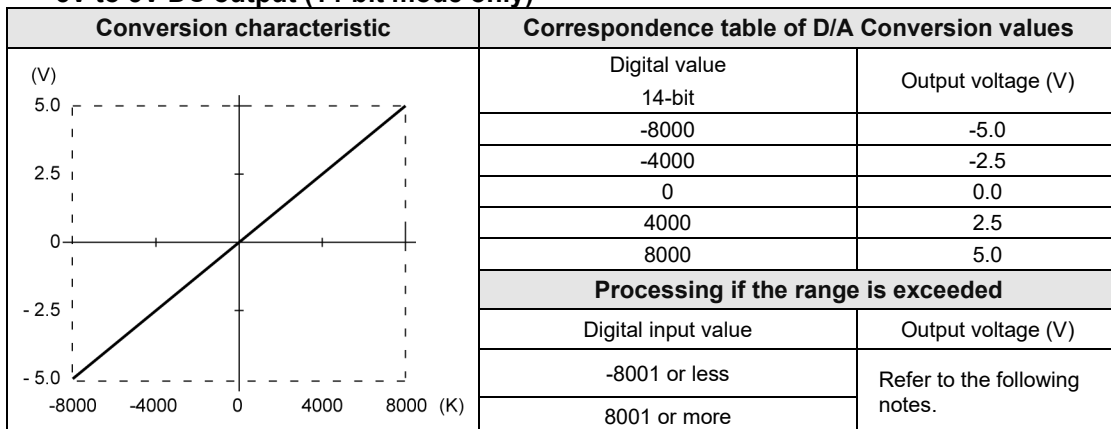

◆ KEY POINTS

- The following operations are performed when a value exceeding the allowable range is written. Always insert a program for checking the upper and lower limits right before a program for writing data.

Mode	Data range		Description
12-bit mode	-2049 or less	2048 or more	The bits D and C of a written value may be regarded as channel switching flags and converted to an unintended value and output.
	-2048 to -2001	2001 to 2047	The value does not change and the previous value is held.
14-bit mode	-8193 or less	8192 or more	The bits F and E of a written value may be regarded as channel switching flags and converted to an unintended value and output.
	-8192 to -8001	8001 to 8191	The value does not change and the previous value is held.

■ 0V to 10V DC output (14-bit mode only)

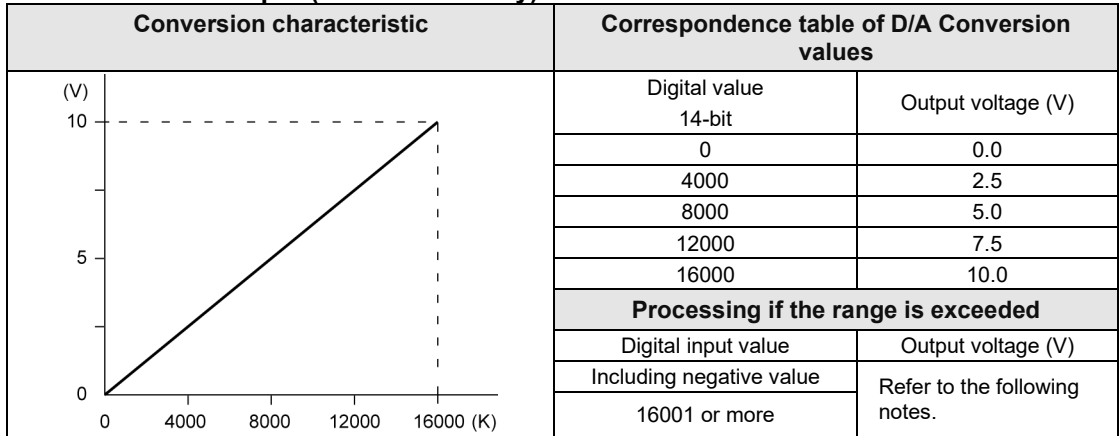

■ 0V to 5V DC output (14-bit mode only)

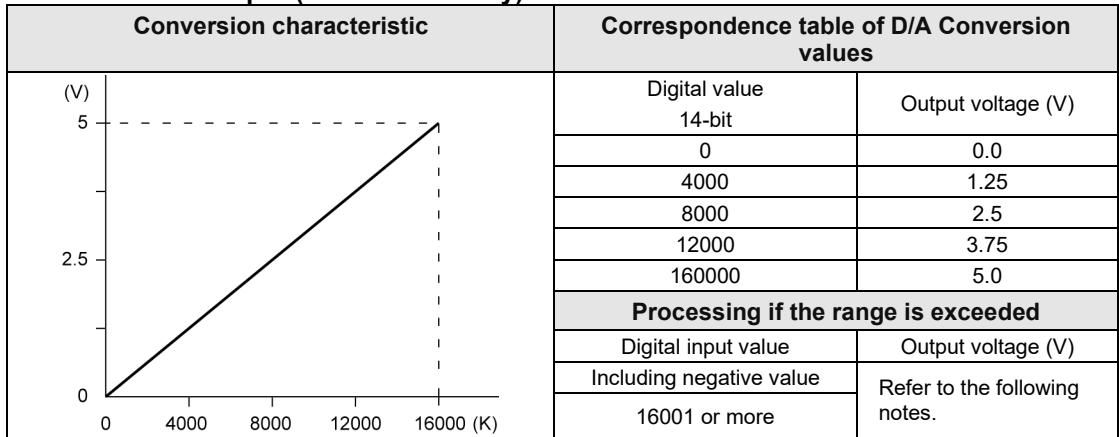

◆ KEY POINTS

- The following operations are performed when a value exceeding the allowable range is written. Always insert a program for checking the upper and lower limits right before a program for writing data.

Mode	Data range		Description
14-bit mode	-1 or less	16384 or more	The bits F and E of a written value may be regarded as channel switching flags and converted to an unintended value and output.
	---	16001 to 16383	The value does not change and the previous value is held.

4.5.4 Output conversion Characteristics (Current Range)

■ 0mA to 20mA output

Conversion characteristic	Correspondence table of D/A Conversion values		
	Digital value		Output current (mA)
	12-bit	14-bit	
	0	0	0.0
	1000	4000	5.0
	2000	8000	10.0
	3000	12000	15.0
	4000	16000	20.0
	Processing if the range is exceeded		
	Digital value		Output current (mA)
	12-bit	14-bit	
Including negative value	Including negative value	Refer to the notes on the next page.	
4001 or more	16001 or more		

(Note):For the 12-bit mode, the values for FP0R-A21/A42 are shown. For FP0R-DA4 (12-bit mode), the range is 4 mA to 20 mA.

■ 4mA to 20mA output

Conversion characteristic	Correspondence table of D/A Conversion values		
	Digital value		Output current (mA)
	12-bit	14-bit	
	0	0	4.0
	1000	4000	8.0
	2000	8000	12.0
	3000	12000	16.0
	4000	16000	20.0
	Processing if the range is exceeded		
	Digital value		Output current (mA)
	12-bit	14-bit	
Including negative value	Including negative value	Refer to the notes on the next page.	
4001 or more	16001 or more		

(Note):For the 12-bit mode, the values for FP0R-DA4 are shown. For FP0R-A21/A42 (12-bit mode), the range is 0 mA to 20 mA.



◆ KEY POINTS

- The following operations are performed when a value exceeding the allowable range is written. Always insert a program for checking the upper and lower limits right before a program for writing data.

Mode	Data range		Description
12-bit mode	-4097 or less	4096 or more	The bits D and C of a written value may be regarded as channel switching flags and converted to an unintended value and output.
	-4096 to -1	4001 to 4095	The value does not change and the previous value is held.
14-bit mode	-1 or less	16384 or more	The bits F and E of a written value may be regarded as channel switching flags and converted to an unintended value and output.
	---	16001 to 16383	The value does not change and the previous value is held.

5

Analog Input Averaging Processing

5.1 Types of Averaging Processing

5.1.1 Moving Average 10 Times

When the averaging function is set to on, the internal processing of the analog unit is as shown in the diagram below

■ **Moving Average Processing**

- Averages and stores converted values obtained by sampling.
- Calculates the average of data for past eight times excluding the maximum and minimum values from the latest data, and stores it in the external input area (WX). If a fraction results from the calculation, it is rounded off.

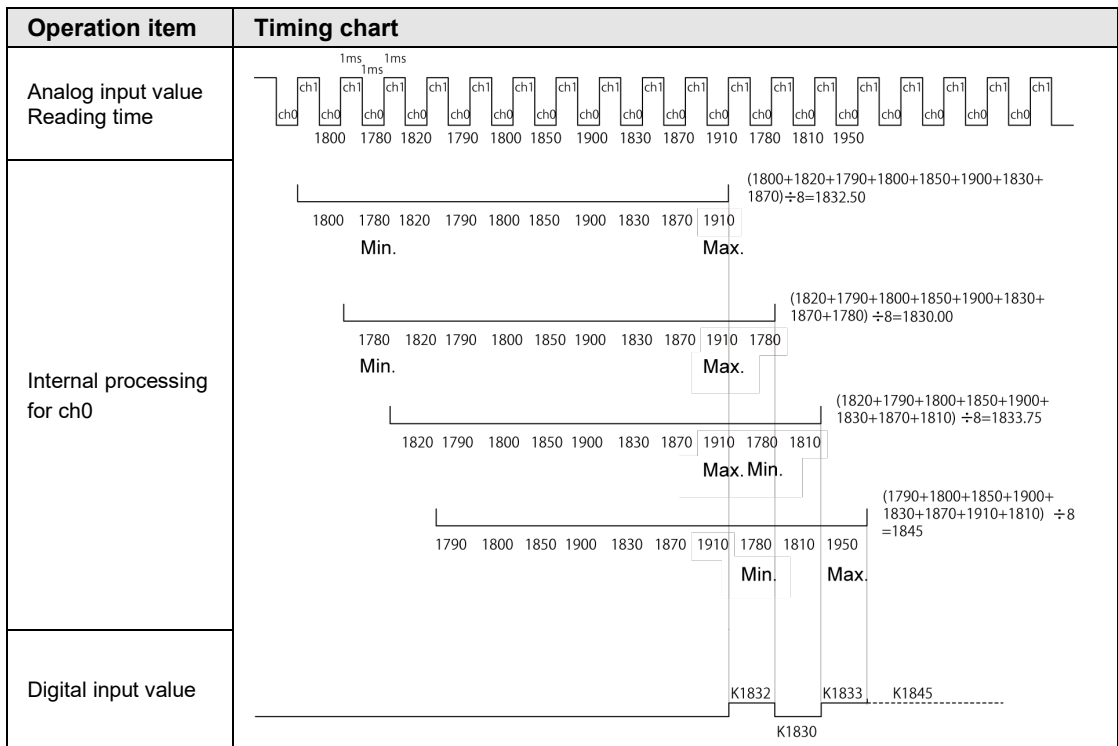

(Note):The above figure shows the processing when the number of input channels is two.

5.1.2 Number of Averaging Times (64 times/128 times: 14-bit Mode Only)

Only when the 14-bit mode is selected, the number of averaging times is selectable.

■ **Processing when selecting the number of averaging times**

- Averages and stores converted values obtained by sampling.
- When the number of obtained analog input data reaches the specified number of averaging times (64 or 128 times), performs the average processing and stores the result as a digital value.
- Stores the first obtained data in the external input area (WX) when the number of obtained data is less than the number of averaging times.

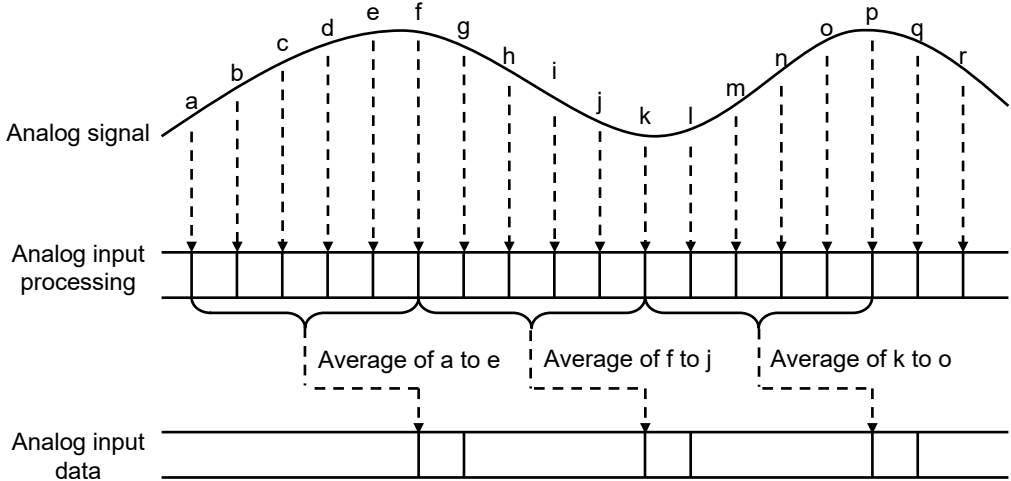

(Note):To make the explanation simple, the above figure shows the processing which averages data by five times. In the actual processing, calculation is carried out with the average of data for 64 times or 128 times.

■ **Setting method of the number of averaging times processing**

The number of averaging times can be changed by being written to the output relay area (WY) in a user program.

5.2 Setting of Averaging Processing

5.2.1 Enabling Averaging Processing

The averaging processing can be set by the following methods.

■ **12-bit FP0-A80 compatibility mode / FP0-A21 compatibility mode**

The averaging processing is enabled only when the mode switch No.5 of the unit is ON.

- The averaging method of all channels is the moving average 10 times (Max. and min. removal).

■ **14-bit mode**

- The averaging processing is enabled only when the mode switch No.5 of the unit is ON.
- The default is the moving average 10 times (Max. and min. removal).
- It is possible to specify the averaging method (Moving average 10 times / No. of averaging times: 64 / No. of averaging times: 128 / No averaging) by a user program for each channel.



◆ REFERENCE

- For details of the setting method of the mode switch, refer to the chapter 2 “Names and Functions of Parts”.
- For details of the programming method for the analog input unit (FP0R-AD4/AD8), refer to “4.2.2 Setting of Input Range and Averaging Processing (14-bit Mode Only)”.
- For details of the programming method for the analog I/O unit (FP0R-A21/A42), refer to “4.4.5 Switching of Input Range and Averaging Method (14-bit Mode Only)”.

6

Specifications

6.1 Table of Specifications

6.1.1 General Specifications

■ Specifications

Item	Description	
Rated operating voltage	24 V DC	
Operating voltage range	20.4 to 28.8 V DC (Unit input voltage)	
Rated current consumption	AFP0RDA4: 180 mA or less AFP0RA21: 80 mA or less AFP0RA42: 120 mA or less	
Allowable instantaneous power-off time	10ms	
Current consumption increase of control unit	AFP0RAD4/ AFP0RAD8 :45 mA or less (Note 1) AFP0RDA4 :10 mA or less AFP0RA21/ AFP0RA42 :10 mA or less	
Ambient temperature	0°C to +55°C	
Storage temperature	-40°C to +70°C	
Ambient humidity	10 to 95%RH (at 25°C non condensing)	
Storage humidity	10 to 95%RH (at 25°C non condensing)	
Breakdown voltage (Note 2)	Between I/O terminal and control unit power supply terminal / ground terminal	500 V AC for 1 minute
	< AFP0RA21/AFP0RA42 > Between analog input terminal and analog output terminal	
Insulation resistance	Between I/O terminal and control unit power supply terminal / ground terminal	Min. 100 MΩ (measured with a 500V DC megger)
	<AFP0RA21/AFP0RA42> Between analog input terminal and analog output terminal	
Vibration resistance	Based on JIS B 3502 and IEC 61131-2: 5 to 8.4 Hz, half amplitude 3.5 mm 8.4 to 150 Hz, constant acceleration 9.8 m/s ² X, Y and Z axes, 10 sweeps (1 octave/mm)	
Shock resistance	Based on JIS B 3502 and IEC 61131-2 147 m/s ² or more, X, Y and Z axes, 3 times	
Noise immunity	1000V [P-P] with pulse widths 50 ns, 1μs (using noise simulator) (Applied to the power supply part of the control unit)	
Operating condition	Must be free from corrosive gases and excessive dust.	
Overvoltage category	Category II	
Pollution level	Pollution level 2	
Weight	AFP0RAD4/ AFP0RA21	:Approx. 75 g
	AFP0RAD8/ AFP0RDA4/ AFP0RA42	:Approx. 85 g

(Note 1): In the case of the unit of Ver.1.2 and after; 20 mA for the unit of Ver.1.1 or older.

(Note 2): Cutoff current: 5 mA (factory default setting).

6.1.2 Input Specifications

Item		Description			
		Analog input unit		Analog I/O unit	
		AFP0RAD4	AFP0RAD8	AFP0RA21	AFP0RA42
Number of channels		4 ch	8 ch	2 ch	4 ch
Input range (Resolution)	Voltage	-10 to 10 V DC (Resolution:1/16,000) (Note 1)			
		-5 to 5 V DC (Resolution:1/16,000)			
	Current	0 to 10 V DC (Resolution:1/16,000)		0 to 5 V DC (Resolution:1/16,000)	
		-100 to 100 mV DC (Resolution:1/4,000) (Note 4)		-	
Digital input range (Note 2)	-10 to 10 V DC	K -2000 to K2000 (12-bit mode)/ K-8000 to K8000 (14-bit mode)			
	-5 to 5 V DC	K-8000 to K8000 (14-bit mode only)			
	0 to 10 V DC 0 to 5 V DC	K0 to K16000 (14-bit mode only)			
	-100 to 100 mV DC (Note 4)	K -2000 to K2000 (12-bit mode only)	-		
	0 to 20 mA	K0 to K4000 (14-bit mode)/ K0 to K16000 (14-bit mode)			
Conversion speed		2 ms / All channels (Note 3)			
Overall precision	Voltage	At ± 100 mV (Note 4)	$\pm 0.6\%$ F.S. or less (at 25°C)		-
		Others	$\pm 1.0\%$ F.S. or less (at 0 to +55°C)		-
	Current	$\pm 0.3\%$ F.S. or less (at 25°C)		$\pm 0.4\%$ F.S. or less (at 0 to +55°C)	
Input impedance	Voltage	Approx.1 M Ω			
	Current	Approx.250 Ω			
Absolute maximum input	Voltage	-15 to 15 V (Voltage input)			
	Current	-30 to 30 mA (Current input)			
Insulation method	Between output terminal to internal circuit	Photocoupler Insulation-type DC/DC converter			
	Between the channels	Uninsulated			
FP0 Compatibility		Switched to the 12-bit operation by the dip switch.			
External connection method		Connection terminal block connection			

(Note 1):The resolution in the 12-bit mode is 1/4,000.

(Note 2): In the analog input unit Ver.1.1 or older or the analog I/O unit, a digital conversion value equivalent to the analog input of approx. 2 V is saved in the device (WX), for the channels to which no input is connected. The analog input unit Ver.1.2 or after are equivalent to approx. 0 V.

(Note 3): The time shown in the figure below is required to reflect analog input values in the input device area (WX) read by the control unit. The following figure shows the values when the range of -10 to +10 V is used.

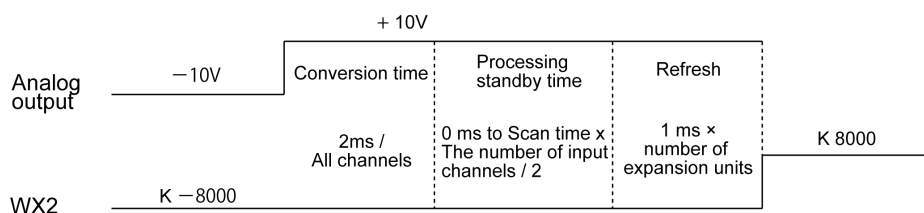

(Note 4): Installed in the unit of Ver.1.2 and after (only 12-bit mode)

6.1.3 Output Specifications

Item		Description		
		Analog output unit	Analog I/O unit	
		AFP0RDA4	AFP0RA21	AFP0RA42
Number of outputs		4 ch	1 ch	2 ch
Output range (Resolution)	Voltage	-10 to 10 V DC (Resolution:1/16,000) (Note 1) -5 to 5 V DC (Resolution:1/16,000) 0 to 10 V DC (Resolution:1/16,000) 0 to 5 V DC (Resolution:1/16,000)		
	Current	0 to 20 mA (Resolution:1/16,000) (Note1) 4 to 20 mA (Resolution:1/16,000) (Note1)		
Digital output range	-10 to 10 V DC	K-2000 to K2000 (12-bit mode)/ K-8000 to K8000 (14-bit mode)		
	-5 to 5 V DC	K-8000 to K8000 (14-bit mode only)		
	0 to 10 V DC 0 to 5 V DC	K0 to K16000 (14-bit mode only)		
	0 to 20 mA 4 to 20 mA	K0 to K4000 (12-bit mode)/ K0 ~ K16000 (14-bit mode) (Note1)		
Conversion speed		500 μs / All channels (Note 2)		
Overall precision	Voltage	±0.2%F.S. or less (at 25°C) ±0.4%F.S. or less (at 0 to +55°C)		
	Current	±0.3%F.S. or less (at 25°C) ±0.6%F.S. or less (at 0 to +55°C)		
Output impedance		0.5 Ω or less (Voltage output)		
Maximum outputcurrent		±10 mA (Voltage output)		
Allowable outputload resistance		600 Ω or less (Current output)		
Insulation method	Between input terminal to internal circuit	Photocoupler Insulation-type DC/DC converter		
	Between the channels	Uninsulated		
External connection method		Connection terminal block connection		

(Note 1):The resolution in the 12-bit mode is 1/4,000. Also, the output current range in the 12-bit mode is 4 to 20 mA for AFP0RDA4, and 0 to 20 mA for AFP0RA21/AFP0RA42.

(Note 2): The time shown in the figure below is required to reflect the values in the output device area (WY) of the control unit as analog output values. The following figure shows the values when the range of -10 to +10V is used.

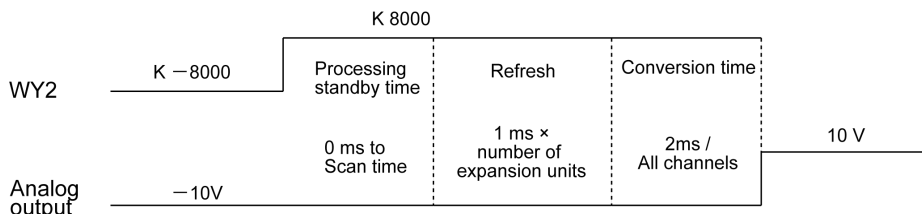

■ Precautions on the characteristics of analog output

- When the power to the control unit turns on or off, voltage (equivalent to 2 V) may be output for approx. 2 ms from the output terminal. If it will be a problem on your system, take necessary measures externally to avoid the transitional condition, e.g. turning on PLC before external devices or turning off external devices before PLC.

6.2 Dimension

■ FP0R-AD4 / FP0R-A21

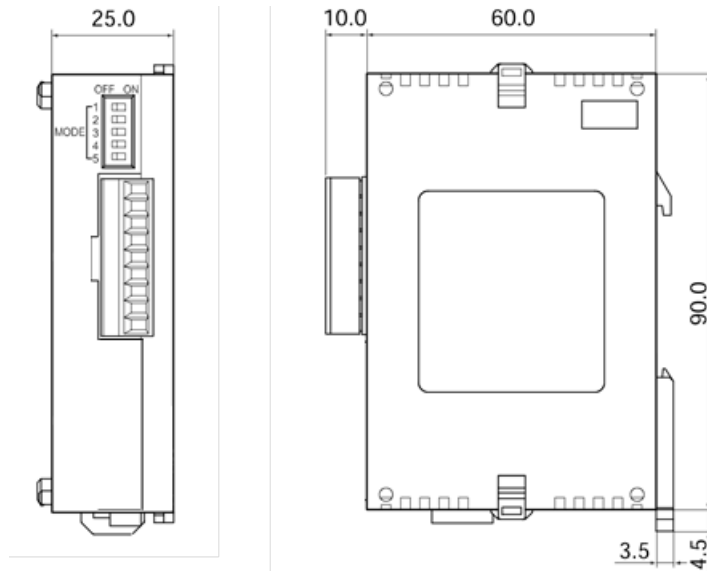

(Note): FP0R-AD4 has no power supply connector.

■ FP0R-AD8 / FP0R-DA4 / FP0R-A42

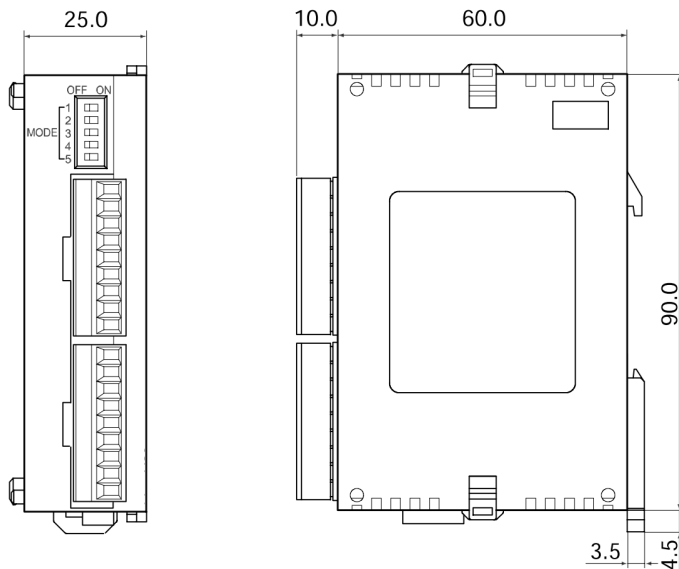

(Note): FP0R-AD8 has no power supply connector.

7

Compatibility with Conventional Models

7.1 Analog Input Unit

7.1.1 Compatibility with Conventional Models

■ Specification Comparison Chart

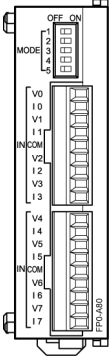
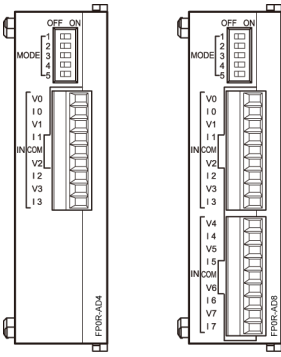
Item		FP0-A80	FP0RAD4 / FP0RAD8
Appearance			
Resolution and Operation mode		12-bit (1/4000)	12-bit (1/4000) 14-bit (1/16000) (Note 1)
Number of channels		8 ch	4 ch or 8 ch (Each model)
Analog input voltage range	-10 to 10 V DC	Not available	Available
	-5 to 5 V DC	Not available	Available (Note 2)
	0 to 10 V DC	Not available	Available (Note 2)
	0 to 5 V DC	Available	Available
	-100 to 100 m V DC	Available	Available (Note 4)
Analog input current range	0 to 20 mA	Available	Available
Conversion speed		1 ms/channel	2 ms/All channels
Overall precision	Voltage	$\pm 0.6\%$ F.S. or less (at 25°C) $\pm 1\%$ F.S. or less (at 0 to 55°C)	At ± 100 mV (Note 4) $\pm 0.6\%$ F.S. or less (at 25°C) $\pm 1.0\%$ F.S. or less (at 0 to 55°C)
	Current		$\pm 0.2\%$ F.S. or less (at 25°C) $\pm 0.4\%$ F.S. or less (at 0 to 55°C)
Analog input averaging function		Available (Moving average)	Available (Moving average 10 times/ No. of averaging times: 64 times or 128 times) (Note 3)
Power supply (24V DC)	External power supply	Needed, 60mA or less	Not needed
	Control unit consumption current increment	20 mA or less	45 mA or less (Note 5)

(Note 1): The resolution and operation mode is switched by the mode switch.

(Note 2): When selecting the 14-bit mode, the range can be set for each channel separately by user programs. Also, the ranges of -5 to 5 V DC and 0 to 10 V DC can be set by user programs only when selecting the 14-bit mode.

(Note 3): When selecting the 14-bit mode, the averaging method can be set for each channel separately by user programs. For details of the averaging methods, refer to the chapter 5 "Analog Input Averaging Processing".

(Note 4): Installed in the unit of Ver.1.2 and after (only 12-bit mode).

(Note 5): In the case of the unit of Ver.1.2 and after; 20 mA for the unit of Ver.1.1 or older.

7.1.2 Points of Replacement

The points for replacing the conventional model FP0-A80 with the new model FP0RAD* as an alternative are described below.

■ Specification

This product can be used equivalently to FP0-A80. (Note 1)

■ Hardware (Note 2)

- The mode switch is set in the same way as FP0-A80. However, if both mode switches 1 and 2 are ON, the product operates in the 14-bit mode. (Note 1)
- The supply of power (24 V DC) from an external device is not needed for the new analog input units FP0R-AD4 and FP0R-AD8.

■ Software

User programs created for the conventional model FP0-A80 can be used as they are.

(Note 1): The units of Ver.1.1 or older cannot be set to the voltage range -100 to +100 mV DC.

(Note 2): In the unit of Ver.1.1 or older, a digital conversion value equivalent to the analog input of approx. 2 V is saved in the device (WX), for the channels to which no input is connected.



◆ REFERENCE

- For details of the setting method of the mode switch, refer to “2.1.2 Setting of Mode Switch”.

7.2 Analog Output Unit

7.2.1 Compatibility with Conventional Models

■ Specification Comparison Chart

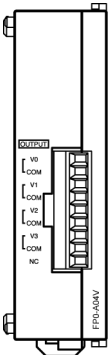
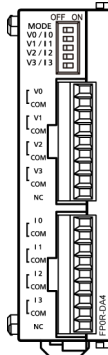
Item		FP0-A04V/ FP0-A04I	FP0RDA4
Appearance			
	DIP switch	None	Equipped
	Terminal block	1	2 (For voltage output / For current output)
Resolution and Operation mode		12-bit (1/4000)	12-bit (1/4000) 14-bit (1/16000) (Note 1)
Number of channels		4 ch	4 ch
Analog output range		Voltage/Current (Each model)	Voltage/Current (Built in one unit)
Analog output voltage range	-10 to 10 V DC	Available (FP0-A04V)	Available (Note 2)
	-5 to 5 V DC	Not available	Available (Note 2)
	0 to 10 V DC	Not available	Available (Note 2)
	0 to 5 V DC	Not available	Available (Note 2)
Analog input current range	0 to 20 mA	Not available	Available (Note 2)
	4 to 20 mA	Available (FP0-A04I)	Available (Note 2)
Conversion speed		500 μs / channel	500 μs / All channels
Overall precision	Voltage	±0.6%F.S. or less (at 25°C) ±1%F.S. or less (at 0 to 55°C)	±0.2%F.S. or less (at 25°C) ±0.4%F.S. or less (at 0 to 55°C)
	Current		±0.3%F.S. or less (at 25°C) ±0.6%F.S. or less (at 0 to 55°C)
Power supply (24V DC)	External power supply	100 mA or less (FP0A04V) 130 mA or less (FP0A04I)	180 mA or less
	Control unit consumption current increment	20 mA or less	10 mA or less

(Note 1):The resolution and operation mode is switched by the mode switch.

(Note 2):When selecting the 14-bit mode, the range can be set for each channel separately by user programs. Also, the ranges of -5 to +5V DC, 0 to 10V DC and 0 to 20 mA DC can be set by user programs only when selecting the 14-bit mode.

7.2.2 Points of Replacement

The points for replacing the conventional models FP0A04V or FP0A04I with the new model FP0RDA4 as an alternative are described below.

■ Hardware

- Turn off the mode switch No.1 and select "12-bit FP0A04 compatibility mode". The voltage output range is "-10 to 10 V DC", and the current output range is "4 to 20 mA DC".
- The new model FP0RDA4 has two terminal blocks for the voltage output and current output. They are connected according to the application.
- In the case of FP0RDA4, select whether to output signals to the voltage output or current output for each channel with the mode switch. The factory default setting is the voltage output for all channels. Change the mode switch setting as necessary.

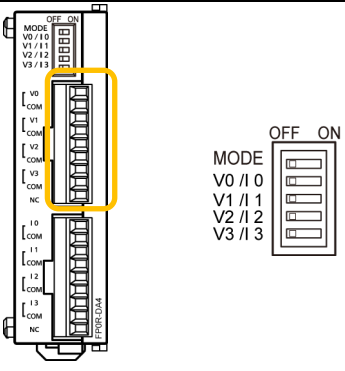
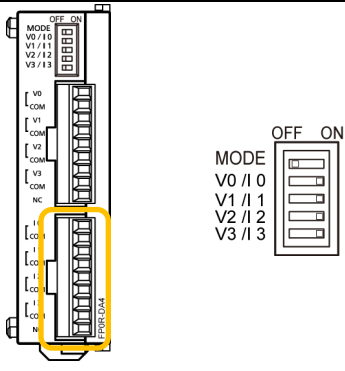
Item	FP0A04V compatibility	FP0A04I compatibility
Appearance		
Terminal block	The terminal block on the voltage output side is used.	The terminal block on the current output side is used.
Mode switch	The 12-bit FP0A04 compatibility mode is selected. The voltage output is selected for all channels.	The 12-bit FP0A04 compatibility mode is selected. The current output is selected for all channels.

■ Software

User programs created for the conventional models FP0A04V and FP0A04I can be used as they are.



◆ REFERENCE

- For details of the setting method of the mode switch, refer to "2.2.2 Setting of Mode Switch".

7.3 Analog I/O Unit

7.3.1 Compatibility with Conventional Models

■ Specification Comparison Chart

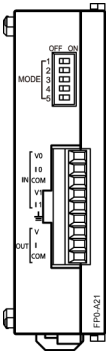
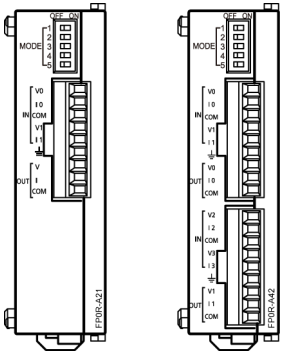
Item		FP0-A21	FP0R-A21 / FP0R-A42
Appearance			
Resolution and Operation mode		12-bit (1/4000)	12-bit (1/4000) 14-bit (1/16000) (Note 1)
Number of channels		Input 2 ch/Output 1 ch	A21:Input 2 ch/Output 1 ch A42:Input 4 ch/Output 2 ch
Analog input voltage range	-10 to 10 V DC	Available	Available
	-5 to 5 V DC	Not available	Available (Note 2)
	0 to 10 V DC	Not available	Available (Note 2)
	0 to 5 V DC	Available	Available
Analog input current range	0 to 20 mA	Available	Available
Analog output voltage range	-10 to 10 V DC	Available	Available
	-5 to 5 V DC	Not available	Available (Note 3)
	0 to 10 V DC	Not available	Available (Note 3)
	0 to 5 V DC	Not available	Available (Note 3)
Analog output current range	0 to 20 mA	Available	Available
	4 to 20 mA	Not available	Available (Note 3)
Conversion speed		1 ms/channel	Input 2 ms / All channels Output 500 μs / All channels
Overall precision	Voltage	±0.6%F.S. or less (at 25°C) ±1%F.S. or less (at 0 to 55°C)	±0.2%F.S. or less (at 25°C) ±0.4%F.S. or less (at 0 to 55°C)
	Current		±0.3%F.S. or less (at 25°C) ±0.6%F.S. or less (at 0 to 55°C)
Analog input averaging function		Not available	Available (Moving average 10 times/ No. of averaging times: 64 times or 128 times) (Note 4)
Power supply (24V DC)	External power supply	100 mA or less	A21:80 mA or less A42:120 mA or less
	Control unit consumption current increment	20 mA or less	10 mA or less

(Note 1): The resolution and operation mode is switched by the mode switch.

(Note 2): When selecting the 14-bit mode, the range can be set for each channel separately by user programs. Also, the ranges of -5 to 5 V DC and 0 to 10 V DC can be set by user programs only when selecting the 14-bit mode.

(Note 3): When selecting the 14-bit mode, the range can be set for each channel separately by user programs. Also, the ranges of 0 to 10 V DC and 4 to 20 mA DC can be set by user programs only when selecting the 14-bit mode.

(Note 4): When selecting the 14-bit mode, the averaging method can be set for each channel separately by user programs. For details of the averaging methods, refer to the chapter 5 "Analog Input Averaging Processing".

7.3.2 Points of Replacement

The points for replacing the conventional model FP0A21 with the new model FP0RA21 as an alternative are described below.

■ Hardware

- Although the positions of the mode switch and the terminal blocks are slightly different between the conventional model FP0A21 and the new model FP0RA21, the setting methods of the switches and the pin layout of the terminal blocks are compatible.
- The mode switch is set in the same way as FP0-A21.
- The connections of the terminal blocks are also the same.
- For the new model FP0RA21, a digital conversion value equivalent to the analog input value of approx. 2 V is shown for the channels to which no input is connected.

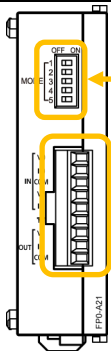
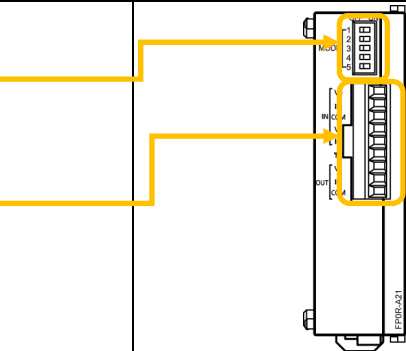
Item	FP0A21	FP0RA21
Appearance		
Mode switch Terminal block	The settings of the mode switches and the wirings of the terminal blocks are the same.	

■ Software

User programs created for the conventional model FP0A21 can be used as they are.

■ Replacement of FP0-A21 with FP0RA42

For replacing two FP0A21 units with FP0RA42, the user program should be changed. The output range is either 0 to 20 mA or -10 to +10 V.



◆ REFERENCE

- For details of the setting method of the mode switch, refer to "2.3.2 Setting of Mode Switch".

Record of changes

Manual No.	Date	Record of Changes
WUME-FP0RAIO-01	June.2015	First Edition
WUME-FPXHAIO-02	Oct.2015	Second Edition -Error correction (Chapter 3.2.1)
WUME-FPXHAIO-03	Nov.2018	Third Edition - Specification change (Chapter 2.1.2, Chapter 4.5.1, Chapter 6.1.1, Chapter 6.1.2, Chapter 7.1.1, Chapter 7.1.2)
WUME-FP0RAIO-04	Apr.2024	Fourth Edition - Change in Corporate name

Panasonic Industry Co., Ltd.

1006, Oaza Kadoma, Kadoma-shi, Osaka 571-8506, Japan
<https://industry.panasonic.com/>

Please visit our website for inquiries and about our sales network.

©Panasonic Industry Co., Ltd. 2015-2024

April, 2024

WUME-FP0RAIO-04