

MAC-I

FINECORSA VERTICALE COMPATTO IN PLASTICA

MAP



- Disponibili per molteplici applicazioni.
- Vasta gamma di attuatori.
- Grado di protezione IP65.
- Apertura positiva dei contatti in conformità alla norma EN 60947-5-1.
- Corpo in tecnopolimero rinforzato con fibra di vetro.
- Doppio isolamento
- Omologato C.E.
- Conforme alle norme CENELEC 50047.

COME ORDINARE

MA	P3	T11	X	1	1		
Tipo di cassetta		Azionamenti		Tipo di contatti		Disposizione dei contatti	
P1: rettangolare in tecnopolimero 1 uscita PG 13.5		T11 - T13 - T14 - T31 - T32 T35 - T36 - T38 - T 41 - T42 T45 - T51 - T52 - T55 - T71 T72 - T73 - T74 - T91 - T92 T98		Z: a scatto rapido W: ad azione lenta simultaneo X: ad azione lenta scalato		11: "NO+NC" 02: "2NC" 20: "2NO"	
P3: rettangolare in tecnopolimero 1 uscita PG 11							

SERIE MAP

Attuatore	Contatto a scatto rapido	Contatto ad azione lenta	
Pistoncino	MAP3T11Z11	MAP3T11X11	MAP3T11W02
Pistoncino a rotella	MAP3T13Z11	MAP3T13X11	MAP3T13W02
Pistoncino con cuffia antipolvere	MAP3T14Z11	MAP3T14X11	MAP3T14W02
Leva con rotella unidirezionale	MAP3T31Z11	MAP3T31X11	MAP3T31W02
Leva laterale con rotella unidirezionale	MAP3T32Z11	MAP3T32X11	MAP3T32W02
Leva con rotella in plastica su pistoncino in metallo con cuffia antipolvere	MAP3T35Z11	MAP3T35X11	MAP3T35W02
Leva con rotella in plastica laterale su pistoncino in metallo con cuffia antipolvere	MAP3T36Z11	MAP3T36X11	MAP3T36W02
Leva regolabile con rotella Ø 22 in plastica su pistoncino in metallo	MAP3T38Z11	MAP3T38X11	MAP3T38W02
Braccio con rotella	MAP3T41Z11	MAP3T41X11	MAP3T41W02
Braccio con rotella in gomma Ø 50	MAP3T42Z11	MAP3T42X11	MAP3T42W02
Braccio con rotella in plastica Ø 18	MAP3T45Z11	MAP3T45X11	MAP3T45W02
Braccio con rotella regolabile	MAP3T51Z11	MAP3T51X11	MAP3T51W02
Braccio con rotella in gomma Ø 50 regolabile	MAP3T52Z11	MAP3T52X11	MAP3T52W02
Braccio regolabile con rotella regolabile in gomma Ø 50	MAP3T55Z11	MAP3T55X11	MAP3T55W02
Asta in acciaio inox Ø 3 mm	MAP3T71Z11	MAP3T71X11	MAP3T71W02
Asta in fibra di vetro Ø 3 mm	MAP3T72Z11	MAP3T72X11	MAP3T72W02
Asta in plastica Ø 6 mm	MAP3T73Z11	MAP3T73X11	MAP3T73W02
Asta in fibra di vetro Ø 6 mm	MAP3T74Z11	MAP3T74X11	MAP3T74W02
Filo a molla multidirezionale	MAP3T91Z11	MAP3T91X11	MAP3T91W02
Asta a molla multidirezionale	MAP3T92Z11	MAP3T92X11	MAP3T92W02
Con anello a strappo	MAP3T98Z11	MAP3T98X11	MAP3T98W02

CARATTERISTICHE

Configurazione dei contatti		1 NO+1 NC - 2NC - 2NO
Resistenza di contatto iniziale		25m ohm
Materiale dei contatti		Ag
Tensione nominale di isolamento		500Vac
Resistenza agli urti	Meccanica	30G
	Diatruttiva	100G
Vita	Meccanica	1X10 ⁷ operazioni
	Elettrica	1X10 ⁵
Temperatura ambientale		-25°+80° C
Umidità ambientale		Max 95% RH
Massima velocità di funzionamento		60cpm
Grado di protezione		IP65

SPECIFICHE (contatto)

Tensione nominale	125VAC	250VAC	400VAC	105VDC
Carico resistivo (cosφ=1)	6,5	4	2,5	0,5
Carico induttivo (cosφ=0,3)	6,5	4	2,5	-

LEGENDA

- A = Punto d'azione
- B = Corsa massima
- C = Punto di rilascio
- D = Corsa differenziale = A-C
- P = Corsa massima di Apertura Positiva

Nota: le misure indicate sono riferite a valori minimi, salvo per la Corsa differenziale.

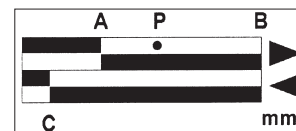
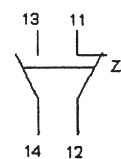

DIMENSIONI

mm Tolleranza generale: ±0.4

Pistoncino

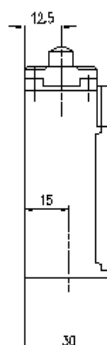
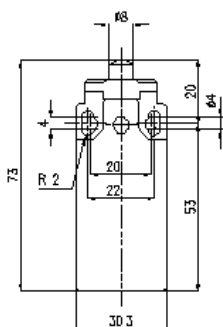

Z11		
X11		
W02		
W20		

MAP3T11

Pistoncino a rotella

mm Tolleranza generale: ± 0.4

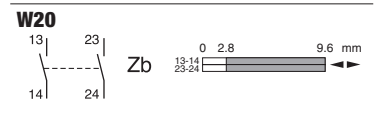
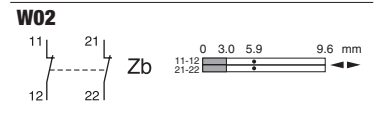
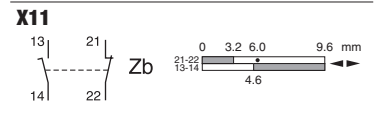
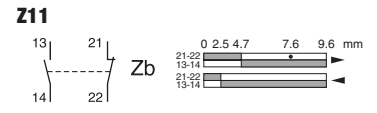
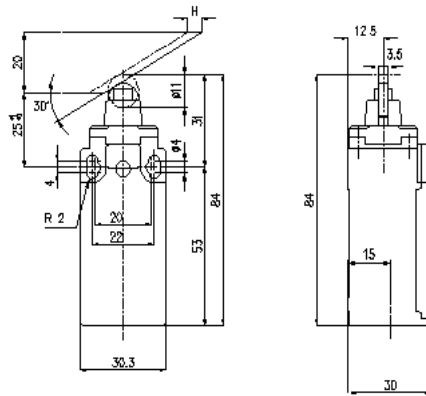

MAP3T13

Pistoncino con cuffia antipolvere

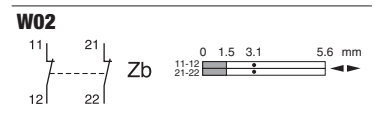
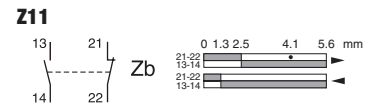
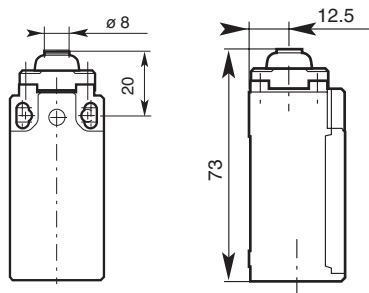

MAP3T14

Leva con rotella unidirezionale

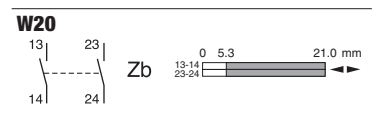
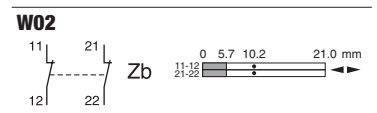
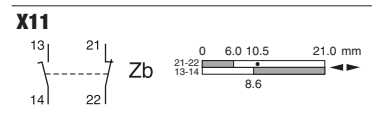
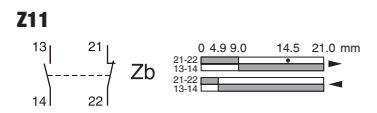
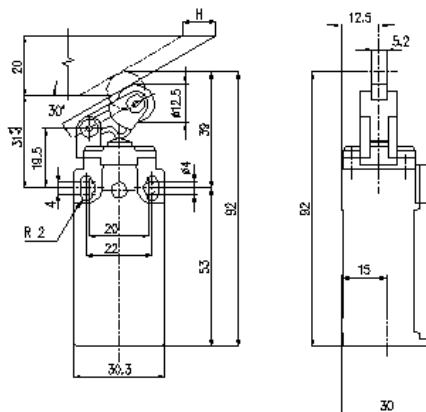

MAP3T31

Leva con rotella unidirezionale

mm Tolleranza generale: ± 0.4

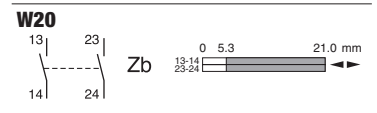
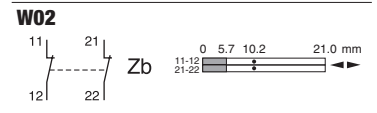
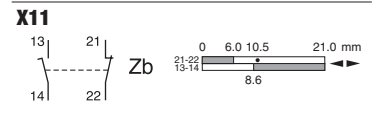
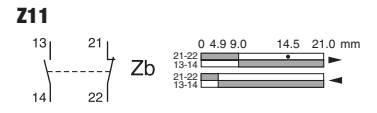
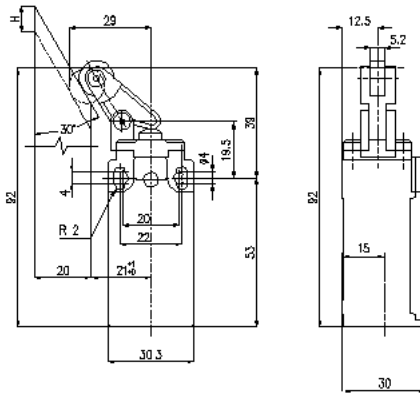

MAP3T32

Leva con rotella in plastica su pistoncino in metallo con cuffia antipolvere

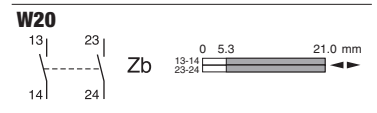
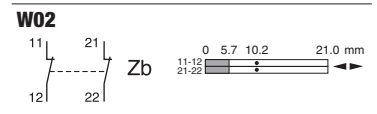
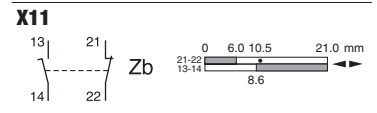
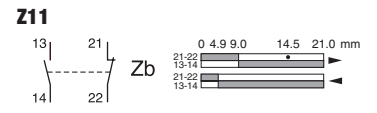
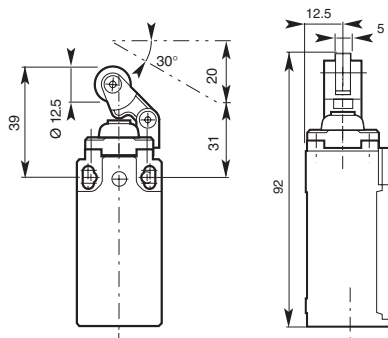

MAP3T35

Leva con rotella in plastica laterale su pistoncino in metallo con cuffia antipolvere

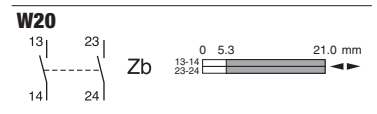
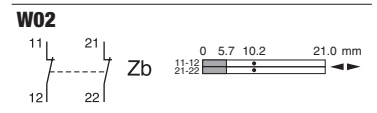
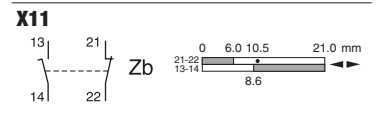
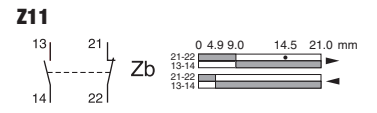
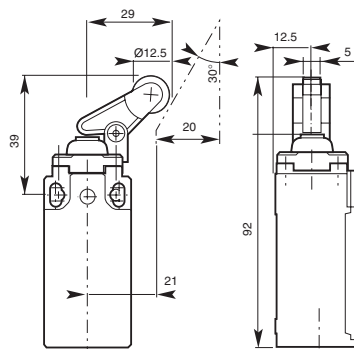

MAP3T36

Leva regolabile con rotella $\varnothing 22$
in plastica su pistoncino in metallo

mm Tolleranza generale: ± 0.4

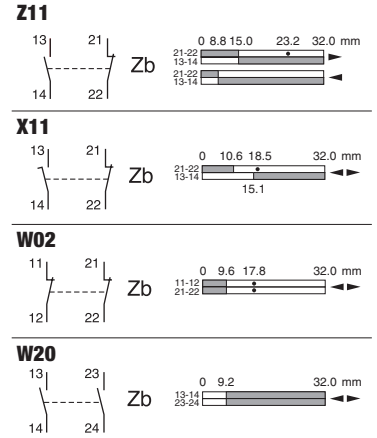
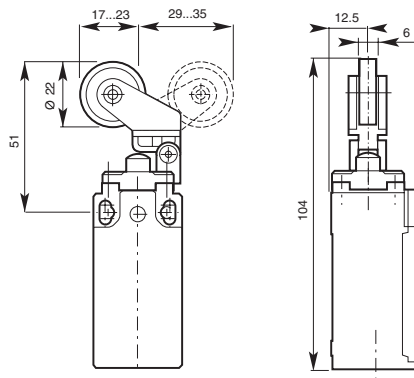

MAP3T38

Braccio con rotella

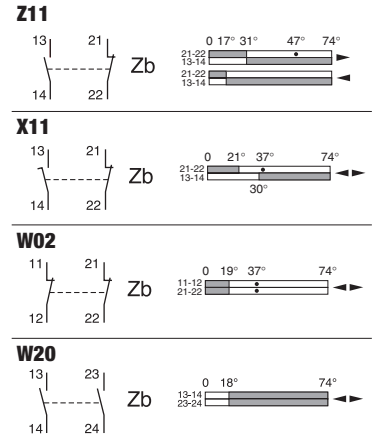
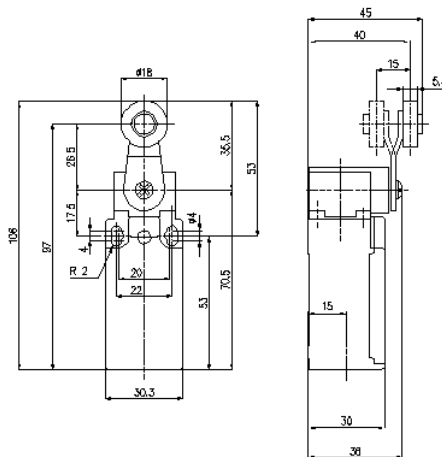

MAP3T41

Braccio con rotella in gomma $\varnothing 50$

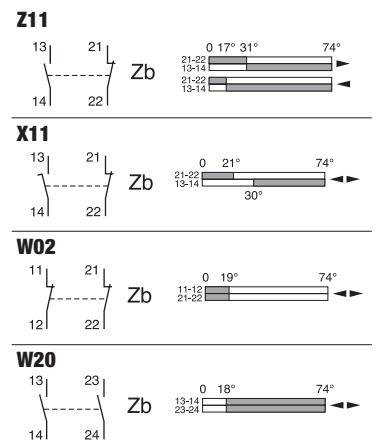
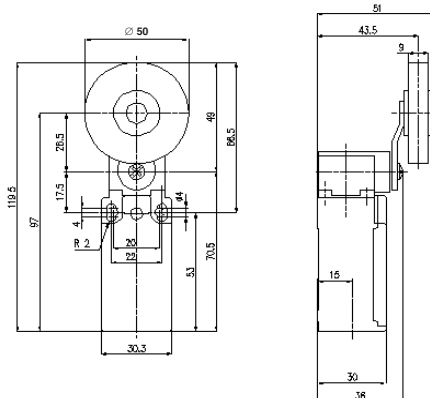

MAP3T42

