

Temperature Control Utilizing SSR

Temperature control applications like heaters or fans require repeated AC switching without any noise. Semiconductor relays like SSRs are uniquely equipped to handle such requirements.

Application Note

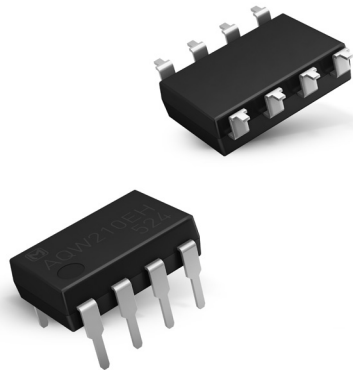

Your Committed Enabler

**IN Your
Future**



IN Your Future

Temperature control

Product

Solid State Relays (SSR) AQ-H

Purpose

Switching motors, solenoids, valves, lamps, heaters or fans in industrial and home appliance applications.

Features

DIP8 package

Currents up to 1.2 A

I/O isolation of 5000 VAC

Typical control current of 5 mA

Long lifetime

Zero cross-switching options available

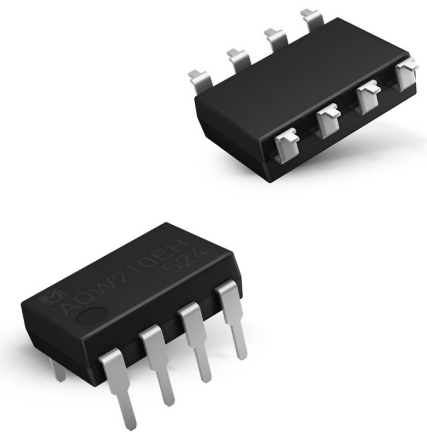

IN Your Future

Temperature control

Facts & Figures

For many years, the electromechanical relay was the only choice for realizing a switching function for an electrical output circuit, which results from the relative movement of mechanical parts. However, semiconductor relays like SSR or PhotoMOS® relays have emerged as attractive alternatives for many switching solutions. While each technology has their advantages and disadvantages, SSRs have proven particularly suited for temperature control applications. An SSR is composed of a low current control side (typically 5 mA to 20 mA, depending on the type of SSR) and a high current load side, whereby the relay provides an electrical I/O isolation of several thousand volts. When current flows through the LED on the input side, it emits light which is detected by a trigger circuit after passing through a silicon resin. The trigger circuit acts like a small triac device and is used to trigger the gate of a larger triac that switches the load in the presence of a load voltage across the triac's output. Once triggered to an on-state, the triac maintains this state until the load current crosses zero and the trigger pulse on the input is absent. Compared to electromechanical relays, semiconductor relays offer a number of advantages. Because there are no mechanical parts, semiconductor relays are more shock resistant and operate noiselessly. They show higher contact reliability, with no contact arcs and a low control current. This enables both a higher switching frequency and an overall long lifetime of the relay.

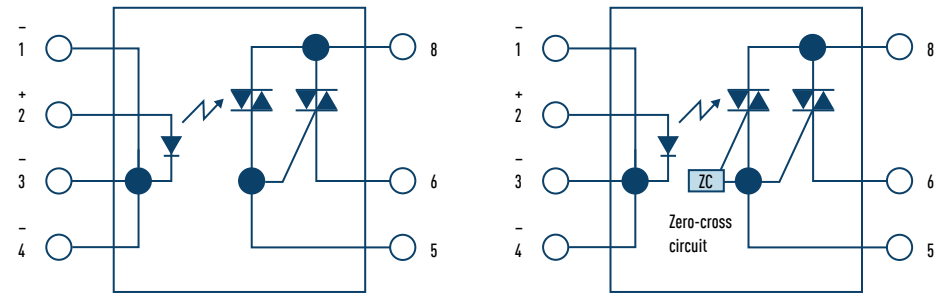

SSRs in particular are an ideal choice for application where AC loads have to be switched repeatedly without creating noise, such as temperature control. This is due to the nature of the triac on the output side: A triac is a four-layer diode with three terminals which can conduct current from anode to cathode and vice versa. It is non-conductive until a current pulse of about 50 mA is applied to its gate. The triac then conducts the load current till the current drops below a certain level.

In temperature control applications, the SSR typically switches a heater or a fan to reach or prevent a certain temperature level. In order to stabilize switching operation once this temperature trigger value is reached, a bistable multivibrator with upper and lower threshold values called a Schmitt trigger is used.

IN Your Future

Temperature control

Facts & Figures

When the signal reaches the upper threshold value V_h , the output of the Schmitt trigger alternates and will remain in this state until the input signal drops below the lower threshold value V_l . The level of the output depends on the supply voltage of the circuit.

The Schmitt trigger can also be realized with discrete transistors, with a voltage divider consisting of a resistor and a thermistor acting as the input signal. If there is no input voltage, the transistor T_1 is in the off-state. The voltage divider R_1 and R_2 instead directs current to the base of transistor T_2 , causing current to flow through T_2 and R_E . If the input voltage V_{in} exceeds the threshold value, current flows through T_1 and the voltage drop across the voltage divider R_1 and R_2 gets lower, reducing the base current of T_2 and

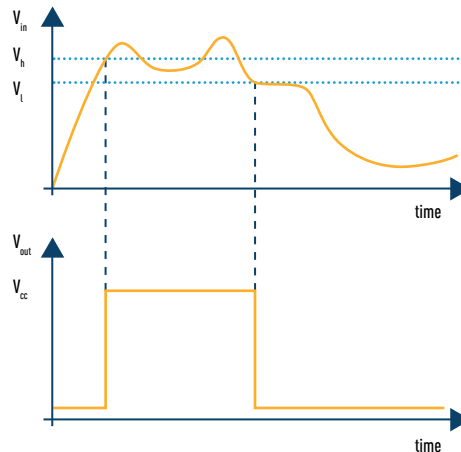

voltage drop across R_E . This makes it easier for transistor T_1 to reach the saturation region and turn into on-state. Consequently, the output voltage V_{out} also rises. If the input voltage drops below the lower threshold value V_l , the transistor T_1 turns off and T_2 turns on, forcing the output voltage V_{out} to drop.

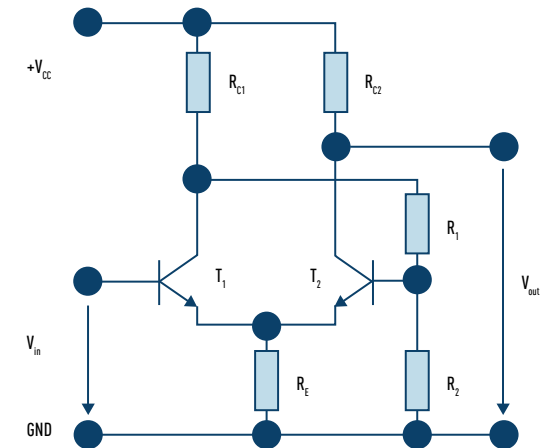

To ensure smooth operation, the thermistor must have good thermal coupling to the ambient, without the current flowing through the voltage divider affecting the accuracy of temperature measurement. By connecting the temperature-dependent voltage divider or bridge circuit to the input of the trigger, the output voltage reflects the temperature accurately – an ideal set-up for controlling the temperature of a heater or fan.

IN Your Future

Learn
more about
PhotoMOS®
technology

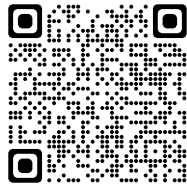

Get
here the
PhotoMOS®
relay App!

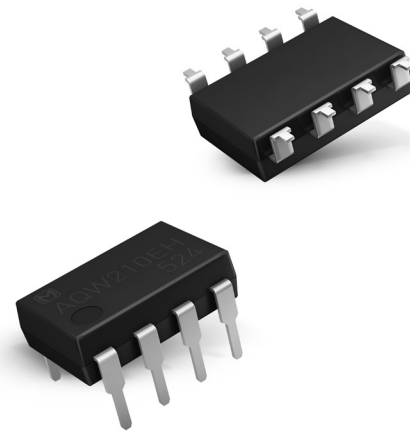

Application Note - How to solve various tasks with with Solid State Relays (SSR) AQ-H

Date: April 2024

Contact: Panasonic Industry Europe GmbH, photomos@eu.panasonic.com

Notes: Data and descriptions in this document are subject to change without notice.

Product renderings are for illustration purposes only and may differ from the real product appearance.